



User Guide

Table of contents

1	User Guide. Introduction	28
1.1	General Information	28
1.2	Purpose of the Document.....	28
1.3	Purpose and functionality of Axxon Next	28
2	Software Lifecycle Policy.....	30
2.1	Software Lifecycle Phases	30
2.2	Software Technical Support.....	30
2.3	Standard Period for Release of Software Updates	30
2.4	Licensing Policy with Regard to Software Updates	30
3	Description of the Software Package.....	31
3.1	Basic principles of building a security system based on the Axxon Next software package	31
3.2	Axxon Next features: reference information.....	31
3.2.1	Micromodule architecture	31
3.2.2	Support for IP cameras	32
3.2.3	Support for analog cameras in Axxon Next	32
3.2.4	Video and Audio Detection Tools	32
3.2.5	Video archive	33
3.2.6	Interactive 3D Map	33
3.2.7	User Interface	33
3.2.8	Face Recognition.....	34
3.2.9	NumberPlate Recognition	34
3.2.10	Receiving Events from External Systems.....	34
3.3	Functions of the Distributed Security System	34
3.4	Network Topologies of the Axxon Next Software Package.....	35
3.5	Specifications of the Axxon Next Software Package.....	35
3.6	Implementation Requirements for the Axxon Next Software Package	36
3.6.1	Limitations of the Axxon Next Software Package	36
3.6.2	Operating system requirements	38
3.6.3	Disk storage subsystem requirements.....	39
3.6.3.1	General requirements.....	40
3.6.3.2	Storage requirements.....	40
3.6.3.2.1	Minimum requirements	40

3.6.3.2.2	Size of archives.....	40
3.6.3.2.3	Database of the system log	41
3.6.3.2.4	Object trajectory database	41
3.6.3.2.5	Self-diagnostics service	42
3.6.4	Hardware requirements	42
3.6.4.1	General hardware requirements.....	42
3.6.4.1.1	Minimal RAM requirements	42
3.6.4.1.2	Minimum and recommended requirements for graphics cards	42
3.6.4.2	Hardware requirements for neural analytics operation	43
3.6.4.3	Hardware requirements for GPU based video decoding	44
3.6.4.4	Hardware requirements for Licence plate recognition (RR).....	44
3.6.4.5	Hardware requirements for face detection	44
3.6.4.6	Hardware requirements for Licence plate recognition (VT)	45
3.6.5	TCP/IP Network Bandwidth Requirements	45
3.6.6	BIOS configuration requirements	45
3.6.7	Running Axxon Next VMS in Virtual Machines	45
3.7	Interface of the Axxon Next Software Package	46
3.8	Ports used by the Axxon Next Software Package	47
3.9	Requirements for Personnel Quantity and Qualifications.....	47
4	Installing the Axxon Next Software Package	49
4.1	Installing equipment.....	49
4.1.1	Types of Devices Used	49
4.1.2	Connecting IP Devices	49
4.1.3	Configuring IP Devices in Windows.....	50
4.1.4	Video capture cards pins	50
4.1.4.1	WS-216 video capture card pins.....	50
4.2	Installation the Axxon Next Software Package	51
4.2.1	Installation	51
4.2.2	Installing DetectorPack add-ons.....	62
4.2.3	Repairing Installation	63
4.2.4	Removal.....	65
4.2.5	Update	67
4.2.6	Silent install (Quiet Mode)	68
4.2.7	Updating Drivers Pack	71
4.2.8	Automatic update of a remote Client	72

5	Licensing of the software product	74
5.1	Axxon Next license types	74
5.2	Licensing methods	77
5.3	Product Activation Utility	77
5.4	License Activation	79
6	Launching and Closing the Axxon Next Software Package	80
6.1	Startup	80
6.1.1	Starting a Server.....	80
6.1.2	Starting an Axxon Next Client.....	80
6.1.3	Running multiple Axxon Next Clients.....	84
6.1.4	Axxon Next in demo mode.....	84
6.1.5	Automatic Start of the Client.....	85
6.2	Shutdown	85
6.2.1	Shutting down an Axxon Next Client.....	85
6.2.2	Shutting down a Server	86
6.3	Automatic Server restart	86
6.4	Switching Users Quickly	86
6.5	Cross-System Client	87
6.6	Connecting LDAP users.....	88
6.7	Connecting to Another Server Quickly.....	88
7	Configuration of the Axxon Next Software Package	90
7.1	General information on system configuration	90
7.1.1	System configuration: stages	90
7.1.2	Applying and resetting settings.....	90
7.1.3	Display of parameters in interface	91
7.1.4	System objects	91
7.1.5	Object search	92
7.2	Hardware configuration	93
7.2.1	Configuring Axxon domains	93
7.2.1.1	Axxon-domain object.....	94
7.2.1.2	Axxon Domain operations	95
7.2.1.2.1	Creating a new domain.....	95
7.2.1.2.2	Adding a Server to an existing Axxon Domain	95
7.2.1.2.3	Removing a Server from an Axxon Domain	97

7.2.1.3	Cases of Axxon Domain configuration	97
7.2.2	Adding and removing IP devices	99
7.2.2.1	Bulk creation of IP devices	103
7.2.3	Configuring System Objects for Devices	104
7.2.3.1	The Server Object.....	104
7.2.3.1.1	Configuring the web server	105
7.2.3.1.2	Configuring an RTSP Server	106
7.2.3.2	The Video Camera Object	107
7.2.3.2.1	Restoring default camera settings	111
7.2.3.2.2	Mass configuration.....	111
7.2.3.2.3	Configuring an Adaptive Video Stream.....	112
7.2.3.2.4	Configuring fisheye cameras	113
7.2.3.2.5	Connecting and configuring cameras over standard protocols.....	114
7.2.3.2.5.1	Notes on configuring video cameras connected via ONVIF.....	114
7.2.3.2.5.2	Configuring connection of video cameras via RTSP	116
7.2.3.2.5.3	Connecting cameras via the GB/T28181 protocol.....	117
7.2.3.2.5.4	Generic Drivers (General device, generic).....	127
7.2.3.2.5.5	Connecting and setting up devices with FFmpeg driver.....	128
7.2.3.2.6	Configuring connection of video cameras with dynamic IP addresses	134
7.2.3.2.7	Configuring virtual video cameras	134
7.2.3.2.8	Privacy mask settings	135
7.2.3.2.9	Putting a text over the camera window.....	136
7.2.3.3	The IP Server Object.....	138
7.2.3.3.1	Configuring Virtual IP Servers.....	139
7.2.3.4	The Microphone Object	140
7.2.3.5	The PTZ Object	141
7.2.3.5.1	Configure HTTP-CGI commands to control Wash&Wiper	142
7.2.3.6	The Channel object	143
7.2.3.7	The Input Object	143
7.2.3.7.1	Configure Virtual Inputs.....	144
7.2.3.8	The Output Object	145
7.2.3.9	The Speaker Object.....	147
7.2.3.9.1	Creating and Configuring an Object.....	148
7.2.3.9.2	Configuring a Speaker Object.....	149
7.2.3.9.3	Checking Audio Notification.....	150

7.2.3.10	The Embedded Storage object.....	150
7.2.4	Particulars of Configuration of Devices	151
7.2.4.1	AGRG-IO-16/8-WD-DS Sensor-Relay cards.....	151
7.2.4.1.1	Connecting AGRG-IO-16/8-WD-DS Sensor-Relay cards.....	151
7.2.4.1.2	Electrical and technical specifications of AGRG-IO-16/8-WD-DS devices	153
7.2.4.1.3	Special features of configuring AGRG-IO-16/8-WD-DS card in Axxon Next.....	154
7.2.4.2	Axis IP Devices	154
7.2.4.2.1	Serial number check	154
7.2.4.2.2	Bonjour function	154
7.2.4.2.3	Video streams.....	155
7.2.4.3	CCTV Keyboards.....	155
7.2.4.3.1	General Information about CCTV Keyboards	155
7.2.4.3.2	Axis T8310 specific configuration features	156
7.2.4.3.2.1	Setting up on a Server.....	156
7.2.4.3.2.2	Setting up on a Client.....	156
7.2.4.3.3	Hikvision DS-1100KI specific configuration features	156
7.2.4.3.4	UNIVIEW KB-1100 specific configuration features	157
7.2.4.3.4.1	General description of the UNIVIEW KB-1100 PTZ control device.....	157
7.2.4.3.4.2	Configuring a remote control before adding it to Axxon Next.....	158
7.2.4.3.4.3	Configuring UNIVIEW KB-1100 in Axxon Next	158
7.2.4.3.5	Hikvision DS-1200KI specific configuration features	159
7.2.4.3.5.1	Configuring the Hikvision DS-1200KI control device before adding it to Axxon Next	159
7.2.4.3.5.2	Features of the Hikvision DS-1200KI control device operation in Axxon Next	160
7.2.4.3.6	Dahua DH-NKB1000 specific configuration features	160
7.2.4.3.6.1	Keyboard operating modes.....	160
7.2.4.3.6.2	Specific OS settings.....	161
7.2.4.3.6.3	Specific Axxon Next settings.....	161
7.2.4.4	CH VM-Desktop USB multifunction controller.....	161
7.2.4.5	Configuring Vivotek Panoramic PTZ	161
7.2.4.6	Video capture cards	161
7.2.4.6.1	WS-216 video capture cards	161
7.2.4.6.2	YUAN PD652 cards.....	162
7.2.4.7	Joysticks	163
7.2.4.8	Sony IP Devices	163
7.2.4.9	Setting up Tibbo relay/loop boards.....	163
7.2.5	Configuring object tracking.....	166

7.2.5.1	Configuring Tag & Track Lite	166
7.2.5.2	Configuring Tag & Track Pro.....	166
7.2.5.2.1	Camera requirements for Tag & Track Pro	166
7.2.5.2.2	Configuring Smooth Motion for PTZ cameras.....	166
7.2.5.2.3	Linking panoramic cameras to a PTZ camera	167
7.2.5.2.4	Mapping PTZ positions to panoramic field of view (calibration)	167
7.2.5.2.5	Setting PTZ mode for Tag & Track Pro.....	169
7.2.6	Receiving Events from External Systems.....	169
7.2.6.1	Event Source Object.....	169
7.2.6.2	Configuring POS devices.....	170
7.2.6.2.1	Connecting POS devices	170
7.2.6.2.2	Configuring titles view	170
7.2.6.2.3	Configuring receipt beginning / end	172
7.2.6.2.4	Configuring keywords.....	173
7.2.6.2.5	Importing parcels	174
7.2.6.3	Receiving Intellect Events.....	175
7.2.6.4	Configuring Receiving Events from CommaxComplexServer	176
7.2.6.4.1	Configuring CommaxComplexServer via Event Source.....	176
7.2.6.4.2	Configuring CommaxComplexServer via virtual IP server.....	177
7.2.7	Configuring video camera groups.....	178
7.2.7.1	Procedure for configuring video camera groups	179
7.2.7.2	Creating a Group object.....	179
7.2.7.3	Adding video cameras created in the system to Group objects	180
7.2.7.4	Creating a system of groups and subgroups	181
7.2.7.5	Managing Group and Video camera objects.....	181
7.2.8	Autocopy data from local to centralized servers	183
7.3	Configuring Archives	185
7.3.1	General information of configuring archives.....	185
7.3.2	General information of SolidStore file system	186
7.3.3	Creating archives	186
7.3.3.1	Creating a local archive	186
7.3.3.2	Creating a network archive	188
7.3.3.3	Creating an archive based on existing archive volumes.....	190
7.3.4	Binding a camera to an archive.....	191
7.3.5	Setting the default archive	193

7.3.6	Configuring data replication	194
7.3.7	Configuring access restrictions to older footage	195
7.3.8	How to preserve Video Footage continuity after replacing a video source	195
7.3.9	Protecting video footage from FIFO overwriting.....	196
7.3.9.1	Setting up a macro for automatic copying of protected records	196
7.3.9.2	Setting up record protection	197
7.3.10	Increasing capacity of an archive volume	198
7.3.10.1	Increasing capacity of an archive volume as a partition	198
7.3.10.2	Increasing capacity of an archive volume as a file.....	199
7.3.11	Editing archives.....	199
7.3.12	Deleting and formatting archive volumes	199
7.3.13	Deleting archives.....	200
7.3.14	View information about the size of archives and Server disk space.	201
7.3.15	Saving the archive when replacing a video source	202
7.4	Configuring detection tools.....	202
7.4.1	General Information on Configuring Detection.....	202
7.4.2	General information on metadata	204
7.4.3	General information on Neural Analytics	205
7.4.3.1	Requirements to data collection for neural network training.....	205
7.4.4	Detection tools implementation on processors.....	206
7.4.5	Creating Detection Tools	207
7.4.6	VMD (video motion detection).....	209
7.4.6.1	Video requirements for VMD.....	209
7.4.6.2	VMD features and specifications	210
7.4.6.3	Configuring VMD.....	210
7.4.7	Service Video Detection Tools	212
7.4.7.1	Functions of Service Video Detection Tools	212
7.4.7.2	Video Requirements for Service Video Detection Tools.....	213
7.4.7.3	Set Parameters of Video Detection	213
7.4.8	Service Audio Detection Tools.....	214
7.4.8.1	Functions of Service Audio Detection Tools	214
7.4.8.2	Set Parameters of Audio Detection.....	215
7.4.9	Scene Analytics	215
7.4.9.1	Functions of Scene Analytics.....	215
7.4.9.2	Video requirements for scene analytics detection.....	216

7.4.9.2.1	Video requirements for object tracker-based scene analytics.....	216
7.4.9.2.2	Video requirements for object tracker (with neural filter)-based scene analytics.....	217
7.4.9.2.3	Video requirements for neural tracker-based scene analytics.....	217
7.4.9.2.4	Video requirements for VMD-based scene analytics.....	218
7.4.9.3	Camera requirements for neural filter operation.....	219
7.4.9.4	Camera requirements for neural tracker operation	219
7.4.9.5	Camera requirements for abandoned objects detection	219
7.4.9.6	Configuring Scene Analytics Detection Tools.....	220
7.4.9.6.1	General information on Scene Analytics	220
7.4.9.6.2	Setting up Tracker-based Scene Analytics	220
7.4.9.6.2.1	Setting General Parameters	220
7.4.9.6.2.2	Settings Specific to Cross Line Detection	229
7.4.9.6.2.3	Settings specific to Abandoned Object detection.....	231
7.4.9.6.2.4	Settings Specific to Loitering Detection	232
7.4.9.6.2.5	Settings Specific to Multiple objects.....	232
7.4.9.6.2.6	Settings Specific to Stop in area detection	233
7.4.9.6.2.7	Settings Specific to Move from area to area detection.....	233
7.4.9.6.3	Setting up Neural Tracker-based Scene Analytics	234
7.4.9.6.4	Setting up VMD-based Scene Analytics.....	236
7.4.10	Face detection tool	237
7.4.10.1	Functions of facial detection.....	237
7.4.10.2	Camera requirements for facial detection	237
7.4.10.3	Configure Facial Recognition	237
7.4.10.3.1	Setting up advanced facial detection tools.....	239
7.4.10.3.1.1	Configuring masks detection	239
7.4.10.3.1.2	Configuring appearance in area detection.....	240
7.4.10.3.1.3	Configuring loitering in area detection.....	241
7.4.10.3.2	Fine-tuning the facial recognition tool	242
7.4.10.4	Configuring real-time facial recognition.....	242
7.4.10.4.1	Setting the automatic response to an identification of a recognized face against the list	243
7.4.10.4.1.1	Examples of macros used for working with face lists	244
7.4.10.4.2	Configuring FaceCube integration	247
7.4.11	Face Detection and Temperature Control with Mobotix M16 TR cameras.....	248
7.4.11.1	Functional parameters of the Face Detection and Temperature Control	248
7.4.11.2	Camera requirements for face detection and temperature control	248
7.4.11.3	Temperature screening protocol	248

7.4.11.4	Pre-configuration of the Mobotix M16 TR camera	249
7.4.11.5	Configuring Face Detection and Temperature Control	252
7.4.12	Automatic Number Plate Recognition (LPR/ANPR) tools	254
7.4.12.1	License plate recognition (VT)	254
7.4.12.1.1	License plate recognition (VT) features and specifications	254
7.4.12.1.2	Camera requirements for License plate recognition (VT)	255
7.4.12.1.3	Configuring License plate recognition (VT)	256
7.4.12.1.4	Fine-tuning the VT number plate detection tool.....	259
7.4.12.1.5	Activating a software license key for the ANPR.....	261
7.4.12.1.6	Activating the trial version of the ANPR via a software key	263
7.4.12.2	License plate recognition (IV)	264
7.4.12.2.1	License plate recognition (IV) features and specifications	264
7.4.12.2.2	Camera requirements for License plate recognition (IV)	264
7.4.12.2.2.1	Examples of correct and incorrect video images	264
7.4.12.2.3	Configuring License plate recognition (IV)	265
7.4.12.3	License plate recognition (RR)	268
7.4.12.3.1	License plate recognition (RR) features and specifications	268
7.4.12.3.2	Camera requirements for License plate recognition (RR)	268
7.4.12.3.3	Configuring License plate recognition (RR)	269
7.4.12.4	Configuring real-time vehicle license plate recognition	271
7.4.12.4.1	Setting the automatic response to an identification of a recognized LP against the list	271
7.4.13	Neural Counter	271
7.4.13.1	Camera requirements for neural counter operation	271
7.4.13.2	Functions of the neural counter	272
7.4.13.3	Configuring a Neuralcounter	272
7.4.14	Fire and Smoke Detection Tools	274
7.4.14.1	Functions of Fire and Smoke detection	274
7.4.14.2	Camera requirements for Fire and Smoke Detection	275
7.4.14.3	Configuring Smoke and Fire Detection Tools.....	275
7.4.15	Equipment detection tool (PPE)	277
7.4.15.1	Functions of the Equipment detection tool (PPE).....	277
7.4.15.2	Camera requirements for the equipment detection tool (PPE)	278
7.4.15.3	Configuring equipment detection tool (PPE)	278
7.4.16	Person-based privacy masking	280
7.4.16.1	Person-based privacy mask functions.....	280

7.4.16.2	Camera requirements for privacy masking	280
7.4.16.3	Person-based privacy mask configuration.....	280
7.4.17	Pose detection tools	281
7.4.17.1	Functions of Pose Detection.....	281
7.4.17.2	Camera requirements for pose detection	282
7.4.17.3	Configure Pose Detection	282
7.4.17.3.1	Setting up common parameters for pose detection tools	282
7.4.17.3.2	Specific settings for People Counter.....	284
7.4.17.3.3	Specific settings for the Man Down detection tool	285
7.4.17.3.4	Specific settings for the Sitting person detection tool	286
7.4.17.3.5	Specific settings for handrail holding detection	288
7.4.17.3.6	Specific settings for people masking	289
7.4.17.3.7	Specific settings for close-standing people detection	290
7.4.18	Retail Analytics.....	292
7.4.18.1	Functions of retail analytics	292
7.4.18.2	Camera requirements for queue detection	292
7.4.18.3	Camera requirements for Visitor Counter operation	293
7.4.18.4	Configuring retail analytics detection tools	294
7.4.18.4.1	Configuring the queue detection tool.....	294
7.4.18.4.2	Configuring the visitors counter.....	295
7.4.19	Water Level Detection.....	298
7.4.19.1	Camera requirements for water level detection	298
7.4.19.2	Configuring water level detection.....	298
7.4.20	Embedded Detection Tools	300
7.4.20.1	Embedded Temperature Detection Tool.....	301
7.4.20.2	Obtaining metadata.....	301
7.4.20.3	ANPR	302
7.4.20.4	AxxonSoft tracking in Axis devices	302
7.4.21	Configuring Inputs	305
7.4.22	Mass Configure Detection Tools.....	305
7.4.23	Checking the Triggering of a Detection Tool	306
7.4.24	Automatic Rules	307
7.5	Configuring Macros	308
7.5.1	General information about the macros	308
7.5.2	Create Macros.....	309

7.5.3	Configuring filters for event-driven macros	312
7.5.3.1	Specific parameters for triggering a face recognition macro	315
7.5.3.2	Triggering macros by statistical data	316
7.5.4	Settings specific to actions	317
7.5.4.1	Wait for event	317
7.5.4.2	Wait for timeout	319
7.5.4.3	Wait till previous action finishes	319
7.5.4.4	Record to archive	321
7.5.4.5	Trigger an alarm	324
7.5.4.6	Switch output	325
7.5.4.7	Arm /disarm a camera	325
7.5.4.8	Switch to a PTZ camera preset	325
7.5.4.9	Show camera	326
7.5.4.10	Opening layout	327
7.5.4.11	Starting export	327
7.5.4.12	Start replication	329
7.5.4.13	Play audio on Server	330
7.5.4.14	E-mail notification	331
7.5.4.14.1	The E-mail Object	333
7.5.4.14.1.1	Creating the E-mail Object	333
7.5.4.14.1.2	Configuring the E-mail Object	333
7.5.4.14.1.3	Checking E-mail Notification	334
7.5.4.15	SMS notification	335
7.5.4.15.1	The SMS Object	336
7.5.4.15.1.1	Procedure of configuring SMS notifications	336
7.5.4.15.1.2	Creating the SMS Object	337
7.5.4.15.1.3	Configuring the SMS Object	337
7.5.4.15.1.4	Checking SMS notifications	338
7.5.4.16	Starting an external program on Clients	338
7.5.4.17	Starting an external program on Servers	338
7.5.4.18	Start / stop slideshows of layouts	340
7.5.4.19	Enable/disable a component	340
7.5.4.20	Checking for archive video recordings	341
7.5.4.21	Switching to Forensic Search results	342
7.5.4.22	Voice notification from Client	342
7.5.4.23	Voice notification on Client	343

7.5.4.24	Executing a macro.....	344
7.5.4.25	Alarm dispatch	344
7.5.4.26	Executing a web query.....	344
7.5.4.27	Text templates in macros	345
7.5.5	Cyclical macros	348
7.6	Configuring user permissions.....	350
7.6.1	Creating and configuring roles.....	351
7.6.2	Connecting to an LDAP catalog.....	356
7.6.3	Working with users.....	358
7.6.3.1	Creating local users.....	358
7.6.3.2	Locking a user account	359
7.6.3.3	Creating LDAP connections	360
7.6.3.4	Synchronize LDAP users	361
7.6.3.5	Deleting users.....	361
7.6.4	Configuring the user security policy	362
7.7	Configuring Layouts.....	363
7.7.1	Creating and deleting layouts	363
7.7.2	Rename Layouts	364
7.7.3	Reorder Layouts.....	365
7.7.4	Layout copying.....	365
7.7.5	Editing layouts	365
7.7.5.1	Switching to layout editing mode	366
7.7.5.2	Selecting a layout for editing	367
7.7.5.3	Configuring layout cells	367
7.7.5.3.1	Adding new cells to a layout.....	367
7.7.5.3.2	Resizing cells	370
7.7.5.3.3	Moving cells	371
7.7.5.3.4	Adding cameras to cells.....	371
7.7.5.3.5	Adding information boards to cells.....	372
7.7.5.3.6	Linking cells.....	372
7.7.5.3.7	Merging videos from adjacent cameras (FrameMerge)	373
7.7.5.3.8	Clearing cells	375
7.7.5.4	Configuring viewing tiles	375
7.7.5.4.1	Selecting default functions for viewing tiles	375
7.7.5.4.2	Select the default video stream for each camera within your layout	376

7.7.5.4.3	Selecting the default video mode for a camera	376
7.7.5.4.4	Moving input and output icons in a viewing tile	376
7.7.5.4.5	Configuring default zoom levels (the Fit screen function).....	377
7.7.5.4.6	Configuring pan/tilt angle for video cameras with Immervision lenses in 1800 Panorama display format	378
7.7.5.4.7	Configuring display of water level detection.....	379
7.7.5.4.8	Adding links to other cameras to the Camera Window	380
7.7.5.5	Configuring information boards	382
7.7.5.5.1	Configuring information board templates	382
7.7.5.5.2	Configuring Events Boards	382
7.7.5.5.3	Configuring a Health Board	384
7.7.5.5.4	Configuring a Statistics Board.....	385
7.7.5.5.5	Configure the Web Board.....	386
7.7.5.5.6	Configure the Dialog Board	387
7.7.5.6	Configuring Alarms Panel on a layout	391
7.7.5.7	Exiting layout editing mode	391
7.7.6	Share Layouts.....	391
7.7.7	Configuring special layouts	392
7.7.7.1	Creating special layouts	392
7.7.7.2	Configuring Alerted Cameras layouts	393
7.7.7.3	Configuring Selected Cameras layout	395
7.7.8	Configuring user-defined slide shows.....	397
7.7.9	Setting the default layout.....	397
7.7.10	Setting a layout ID.....	398
7.8	Configuring Video Wall.....	398
7.9	Configuring the Interactive Map.....	400
7.9.1	Creating a new map	400
7.9.2	Adding system objects to the map.....	403
7.9.2.1	Adding video cameras	403
7.9.2.2	Adding inputs and outputs	404
7.9.2.3	Adding switches to another map	405
7.9.3	Configuring cameras on the map.....	406
7.9.3.1	Configuring a camera in standard map viewing mode.....	406
7.9.3.2	Configuring cameras in immersion mode	407
7.9.3.3	Configuring cameras with a built-in GPS tracker	408

7.9.4	Attaching a map to a layout	409
7.9.5	Removing objects from the map.....	409
7.9.6	Setting keywords for geo map search	410
7.9.7	Changing map type and display.....	410
7.9.8	Renaming the map.....	410
7.9.9	Sorting of map lists	411
7.9.10	Deleting a map	411
7.10	System preferences	411
7.10.1	Server settings.....	411
7.10.1.1	Configuring Forensic Search MomentQuest in Archive	411
7.10.1.1.1	Turning on the video stream metadata recording.....	412
7.10.1.1.2	Configuring user permissions for Forensic Search in archive	412
7.10.1.1.3	Video suitability for Forensic Search of recorded video (requirements)	412
7.10.1.2	Setting up privacy masking	413
7.10.1.2.1	Masking faces	413
7.10.1.2.2	Setting up privacy masking in Video Footage	413
7.10.1.3	Analyzing video from external systems (Offline Analytics).....	416
7.10.1.3.1	Importing video to Axxon Next.....	417
7.10.1.3.2	Indexing video from external sources.....	418
7.10.1.3.3	How to set a folder to import videos from.....	420
7.10.1.4	Configuring hardware video decoding for display on the Client.....	420
7.10.1.4.1	Hardware-based decoding with Intel Quick Sync Video.....	421
7.10.1.4.2	Hardware-based decoding with NVIDIA NVDEC chips	422
7.10.1.4.3	Parallel decoding with both Intel's Quick Sync Video and NVidia's NVDEC	423
7.10.1.5	Configuring automatic response when Axxon Next VMS PC integrity check fails	423
7.10.1.6	Configuring storage of the system log and metadata.....	424
7.10.1.7	Configuring Alarm Management Mode	426
7.10.1.8	Configuring PTZ control	426
7.10.1.9	Configuring schedules	427
7.10.1.9.1	Creating schedules.....	427
7.10.1.9.2	Deleting a schedule.....	428
7.10.1.10	Configuring the Server ports	429
7.10.2	Client settings.....	429
7.10.2.1	Configuring the user interface.....	429
7.10.2.1.1	Selecting the interface language	429

7.10.2.1.2	Selecting the calendar type.....	431
7.10.2.1.3	Configuring Slideshow parameters	432
7.10.2.1.4	Hiding tooltips.....	432
7.10.2.1.5	Configuring animation.....	433
7.10.2.1.6	Configuring Display of Video Statistics	433
7.10.2.1.7	Configuring previews of alarm events	434
7.10.2.1.8	Configuring map autozoom	435
7.10.2.1.9	Configuring the Client screen mode (full screen or window)	435
7.10.2.1.10	Configuring the Appearance of the Viewing Tile	436
7.10.2.1.11	Configure Time Display.....	437
7.10.2.1.12	Configuring the display of the camera ID	438
7.10.2.1.13	Prune Video to Window Resolution	440
7.10.2.1.14	Configuring tiles on the layout	440
7.10.2.1.15	Configuring video display on the map	444
7.10.2.1.16	Configuring camera sorting on Object Panel	445
7.10.2.2	Configuring how Axxon Next starts	446
7.10.2.2.1	Configuring Axxon Next instead of the standard Windows OS shell	446
7.10.2.2.2	Configuring Cross-System Client and autologon	447
7.10.2.2.3	Configuring automatic exiting and locking of the Client	450
7.10.2.2.4	IP address filtering configuration.....	451
7.10.2.2.5	Selecting Preferred Servers	451
7.10.2.3	Configuring export	452
7.10.2.3.1	Configuring export options	452
7.10.2.3.2	Configuring an Export Agent	456
7.10.2.4	Configuring audio on the Client	457
7.10.2.5	Configuring hot keys	458
7.10.2.5.1	Introduction to hot keys in Axxon Next.....	458
7.10.2.5.2	Assigning hot keys.....	458
7.10.2.5.3	Exporting and importing hot keys.....	459
7.10.2.5.4	Notes regarding hot key actions	460
7.10.2.5.5	Joystick Configuration.....	462
7.10.2.6	Configuring video capturing on operator monitor.....	463
7.11	Configuring Failover VMS.....	466
7.11.1	General information about a failover system.....	466
7.11.2	Ports used by the failover system	468

7.11.3	Supervisor Web Interface	468
7.11.4	Creating a Cluster.....	469
7.11.5	Failover Database	472
7.11.6	Configure a Failover System Cluster	473
7.11.6.1	Setting up basic configuration	473
7.11.6.2	Setting up a configuration with the backup Server	477
7.11.6.3	Creating and configuring independent nodes	481
7.11.6.4	1+1 Cluster Configuration.....	484
7.11.6.5	Suspending a Server within a cluster.....	486
7.11.6.6	Disbanding a cluster	486
7.11.7	Set up access to a supervisor	487
7.11.8	Configuration backup and restore for failover VMS.....	488
7.11.9	Cluster Monitoring	489
7.11.10	Connecting to a Node and Configuring of an Axxon domain.....	491
7.11.11	Configuring automatic connections to nodes.....	492
7.11.12	Upgrading Servers within a cluster.....	492
7.11.13	Setting network interfaces for system nodes operation	494
7.12	Self-diagnostics service	494
7.12.1	What is the self-diagnostics service	494
7.12.2	Starting and stopping the self-diagnostics service	495
8	Working with the Axxon Next Software Package	496
8.1	Main Elements of the User Interface	496
8.1.1	Viewing Tile	496
8.1.1.1	Color Coding of Frames	498
8.1.1.2	Viewing Tile Context Menu	499
8.1.1.3	Time Display	499
8.1.1.4	Display of Video Statistics	500
8.1.1.5	Video Surveillance Mode Selection Tabs	501
8.1.1.6	Advanced archive navigation panel.....	502
8.1.2	Information boards.....	503
8.1.3	The Archive Navigation Panel	504
8.1.3.1	Show and Hide the Archive Navigation Panel	504
8.1.3.2	The Structure and Function of the Archive Navigation Panel	504
8.1.3.3	Events Filter.....	506
8.1.3.4	The Timeline.....	507

8.1.3.5	Events List	510
8.1.3.6	The Playback Panel.....	511
8.1.4	Video Wall Panel.....	512
8.1.5	Monitor Panel.....	512
8.1.6	The Layouts panel.....	513
8.1.7	Interactive Map	513
8.1.8	Camera Search Panel.....	514
8.1.9	Alarms Panel	515
8.1.10	Objects Panel	517
8.1.11	The PTZ Control Panel.....	518
8.1.12	Story board.....	520
8.2	Video Surveillance.....	521
8.2.1	Video Surveillance Modes.....	521
8.2.2	Functions Available in All Video Surveillance Modes	521
8.2.2.1	Scaling the Viewing Tile	522
8.2.2.2	Digitally Zooming Video Images.....	523
8.2.2.2.1	Enlarging a video image using the digital zoom scale	523
8.2.2.2.2	Enlarging a video image through area selection.....	524
8.2.2.2.3	Enlarging a video image using the mouse scroll wheel	526
8.2.2.3	Video image processing.....	526
8.2.2.3.1	Changing the Contrast Level	526
8.2.2.3.2	Setting the Sharpness Level	527
8.2.2.3.3	Using Deinterlacing.....	528
8.2.2.4	Rotate Video Image.....	529
8.2.2.5	Tracking objects.....	531
8.2.2.6	Operator comments.....	534
8.2.2.6.1	Adding comments in different surveillance modes	534
8.2.2.6.2	Adding a comment.....	535
8.2.2.7	Viewing titles from POS terminals	536
8.2.2.8	Partial decoding of video.....	538
8.2.3	Real-time video surveillance	538
8.2.3.1	Switching to Live Video Mode.....	538
8.2.3.2	Video Surveillance Functions Available in Live Video Mode.....	539
8.2.3.3	Arming and Disarming a Video Camera	539
8.2.3.4	Controlling a PTZ Camera	540

8.2.3.4.1	Presets	541
8.2.3.4.1.1	Creating and editing presets	541
8.2.3.4.1.2	Selecting a preset.....	543
8.2.3.4.2	PTZ Tours	544
8.2.3.4.2.1	Creating and editing PTZ tours	544
8.2.3.4.2.2	Launching a PTZ tour.....	545
8.2.3.4.3	Control using step buttons and virtual joystick	545
8.2.3.4.4	Patrolling.....	546
8.2.3.4.5	Controlling Focus, Iris and Optical Zoom	547
8.2.3.4.6	Controlling a PTZ Video Camera in the OnScreen PTZ Mode	547
8.2.3.4.7	Control using Point&Click.....	548
8.2.3.4.8	Control using Areazoom	548
8.2.3.5	Functions for tracking of moving objects	550
8.2.3.5.1	Tag & Track Pro	550
8.2.3.5.2	Tag & Track Lite.....	551
8.2.3.5.3	Simultaneously using Tag & Track Pro and Tag & Track Lite	552
8.2.3.6	Managing Outputs.....	552
8.2.3.7	Displaying the input status.....	553
8.2.3.8	Selecting video stream quality in a viewing tile (GreenStream)	554
8.2.3.9	Autozoom	556
8.2.3.10	Autoreplace Offline Cameras on Layouts	558
8.2.3.11	Snapshot	558
8.2.3.12	Viewing selected camera's detection tool triggering events.....	558
8.2.3.13	Switching to other camera via a link in the Camera window	559
8.2.3.14	Removing a camera from a layout	560
8.2.4	Video surveillance in archive mode	561
8.2.4.1	Switching to Archive Mode	561
8.2.4.2	Video Surveillance Functions Available in Archive Mode	563
8.2.4.3	Selecting an Archive.....	563
8.2.4.4	Viewing a combined Archive	564
8.2.4.5	Synchronized playback of archives.....	565
8.2.4.6	Compressed playback of archives (TimeCompressor)	565
8.2.4.6.1	Switching to TimeCompressor mode	566
8.2.4.6.2	Playback control	567
8.2.4.6.3	Switching back to the original recording of an object	568

8.2.4.7	Viewing recorded video with operator comments.....	569
8.2.4.8	Viewing External Archives.....	571
8.2.4.9	Delete a part of an archive.....	571
8.2.4.10	Navigating in the Archive.....	572
8.2.4.10.1	Navigating Using the Timeline	572
8.2.4.10.2	Navigation using the advanced panel	574
8.2.4.10.3	Navigating Using the Events list.....	575
8.2.4.10.4	Navigating Using the Playback Panel	575
8.2.4.10.5	Navigation via the time indicator.....	576
8.2.4.10.6	Keyboard navigation	576
8.2.4.11	Displaying the causes of triggered situation analysis detection units.....	577
8.2.4.12	Viewing the results of a saved search query.....	577
8.2.4.13	Manual Archive Replication	579
8.2.4.14	Tag & Track Lite in Archive mode.....	580
8.2.5	Video surveillance in Alarm Management mode.....	581
8.2.5.1	Video surveillance functions available in Alarm Management mode	581
8.2.5.2	Switch to Alarm Management mode	581
8.2.5.3	Initiating an Alarm	582
8.2.5.3.1	Manual Initiation	582
8.2.5.3.2	Automatic Initiation	583
8.2.5.4	Working with Alarms Panel	584
8.2.5.4.1	Viewing Alarms in Event Preview	584
8.2.5.4.2	Outlining Objects that Triggered Detection	584
8.2.5.4.3	Selecting Events for Alarm Management.....	584
8.2.5.5	Working with the Alarm Management window	585
8.2.5.5.1	Alarm Handling Tile Interface Elements	585
8.2.5.5.2	Alarm Playback	585
8.2.5.5.3	Processing an Alarm	586
8.2.5.6	Limitations when working with alarm events in case of multi-user processing	587
8.2.6	Video surveillance in Archive Search mode.....	588
8.2.6.1	Switching to Archive Search mode	588
8.2.6.2	Archive Search mode interface	589
8.2.6.3	Video surveillance functions available in Archive Search mode	591
8.2.6.4	Search in an archive of a single video camera	592
8.2.6.4.1	Selecting the search type	592

8.2.6.4.2	Setting a search interval.....	592
8.2.6.4.3	Events search	593
8.2.6.4.4	Time search for video fragments (TimeSlice).....	595
8.2.6.4.5	Searching comments	596
8.2.6.4.6	Forensic Search for Fragments (MomentQuest)	596
8.2.6.4.6.1	Motion in Area	597
8.2.6.4.6.2	Loitering of an object in a specific area	598
8.2.6.4.6.3	Simultaneous presence of a large number of objects in a specific area.....	598
8.2.6.4.6.4	Motion from one area to another.....	599
8.2.6.4.6.5	Crossing of a virtual line by an object's trajectory	600
8.2.6.4.6.6	Configure the search parameters	601
8.2.6.4.7	Titles search	605
8.2.6.4.8	LPR search	605
8.2.6.4.9	Face search.....	606
8.2.6.4.9.1	Tell "friend" from "foe" by a picture	608
8.2.6.4.10	Saving search queries	608
8.2.6.4.11	Switching between search results	609
8.2.6.4.12	Working with search results	609
8.2.6.4.12.1	Viewing search results	609
8.2.6.4.12.2	Viewing Search Results In TimeCompressor	611
8.2.6.4.12.3	Playback of video fragments.....	611
8.2.6.4.12.4	Enlargement of found moments	613
8.2.6.4.12.5	Exporting the video fragments and repeated search	614
8.2.6.5	Simultaneous search in an archive of several video cameras.....	614
8.2.7	Working with fisheye cameras	615
8.2.7.1	Viewing modes for video from fisheye cameras.....	615
8.2.7.1.1	Selecting viewing mode for videos from a fisheye camera	615
8.2.7.1.2	360 degree Panorama and Regional view (virtual PTZ).....	616
8.2.7.1.3	180 degree Panorama.....	618
8.2.7.2	Fisheye cameras on an interactive map	618
8.2.7.2.1	Viewing video and controlling a fisheye camera from the map	618
8.2.7.2.2	Fisheye cameras in immersive mode.....	619
8.2.8	Facial recognition and search	620
8.2.9	Vehicle number plate recognition and search	623
8.2.10	Temperature screening	624
8.3	Working with information boards	625

8.3.1	Resizing information boards	625
8.3.2	Hiding information boards	626
8.3.3	Automatically switching to layouts with information boards	626
8.3.4	Working with Events Boards.....	627
8.3.4.1	Options for displaying information on Events Boards.....	627
8.3.4.2	Switching a camera linked to an Events Board to the archives	629
8.3.5	Working with Health Boards.....	629
8.3.5.1	Viewing server status	631
8.3.5.2	Viewing camera status.....	632
8.3.6	Working with Statistics Boards	634
8.3.7	Working with Web Boards	636
8.3.8	Working with Dialog Board.....	637
8.4	Layouts Management	639
8.4.1	Changing cameras within a layout.....	640
8.4.2	Selection and Slideshow of Layouts	640
8.4.3	Working with Special layouts	641
8.5	Monitor Management	643
8.5.1	Managing monitors on a local Client	643
8.5.2	Managing monitors on remote Clients within the Axxon domain.....	645
8.6	Audio Monitoring.....	646
8.6.1	General Information	646
8.6.2	Listening on the Client to sound from a camera microphone.....	647
8.6.3	Playing back sound from Client microphone on camera speakers	648
8.7	Working with the Interactive Map	649
8.7.1	Opening and closing the map	650
8.7.2	Geo map search	651
8.7.3	Changing the map tilt	652
8.7.4	Scaling and focusing of map	653
8.7.5	Customizing an Interactive Map.....	654
8.7.6	Immersive mode	655
8.7.7	Switching between maps	656
8.7.8	Controlling devices from the map.....	658
8.7.9	Displaying device status	659
8.7.10	Selecting Cameras for a Temporary Layout	660
8.8	Exporting Frames and Video Recordings.....	661

8.8.1	Frame export.....	661
8.8.2	Exporting Video Recordings	663
8.8.2.1	Standard video export	663
8.8.2.2	Instant video export.....	665
8.8.2.3	Simultaneous export of video from multiple cameras	666
8.8.2.4	Exporting all event videos	667
8.8.3	Configuring export area and masks	668
8.8.4	Viewing export progress	670
8.9	Macros control	670
8.10	Event Control.....	671
8.10.1	Control in Live Video Mode	671
8.10.2	The System Log.....	671
8.10.2.1	Setting Event Search Filters	671
8.10.2.2	Event search procedure.....	672
8.10.2.3	Refreshing Event Search Results.....	673
8.10.2.4	Viewing Event Search Results.....	673
8.10.2.5	Exporting Event Search Results	674
8.10.2.6	Switching to archive video of specific events.....	675
8.11	Working with Axxon Next Through the Web Client.....	675
8.11.1	Web client overview	675
8.11.2	Hardware and software requirements for the Web Client operation	676
8.11.3	Starting the web client.....	676
8.11.4	Web client's GUI	678
8.11.5	Web Client Configuration	679
8.11.6	Searching for video cameras in the web client	680
8.11.7	Working with layouts in Web Client	683
8.11.7.1	Summary of how to work with layouts in Web Client	683
8.11.7.2	Selecting and searching for a layout.....	683
8.11.7.3	Creating a new layout in Web Client	684
8.11.7.4	Editing and deleting layouts in Web Client.....	685
8.11.7.5	Selecting the default layout in Web Client	685
8.11.7.6	Copying layouts in Web Client.....	686
8.11.7.7	Sharing layouts in Web Client	686
8.11.8	Real-time video surveillance via the web client.....	687
8.11.9	Controlling PTZ cameras through the web client	688

8.11.9.1	Controlling a PTZ camera through the web client by using presets	689
8.11.9.2	Changing the optical zoom of a PTZ camera in the web client	689
8.11.9.3	Changing the positioning speed of a PTZ camera in the web client	689
8.11.9.4	Changing the tilt of a PTZ camera in the web client	689
8.11.10	Viewing video archives through the web client.....	690
8.11.11	Archive position selection panel for the web client	691
8.11.12	Archive search through the web client	692
8.11.12.1	Types of Archive search available via the Web Client	693
8.11.12.2	Building a Heat Map.....	693
8.11.12.3	Simultaneous search in multiple camera Video Footage via the web Client	695
8.11.12.4	Reporting the search results	695
8.11.13	Alarm Monitoring via the Web Client	696
8.11.14	Listening to a camera's microphone via the web client	697
8.11.15	Digital video zoom in the web client.....	698
8.11.16	Export in Web Client.....	698
8.11.17	Viewing Camera and Archive Statistics.....	699
8.11.18	Working with bookmarks in the Web Client	700
8.11.18.1	Editing a bookmark.....	701
8.11.18.2	Deleting a bookmark	702
8.11.18.3	Un-protecting a video	702
8.11.18.4	Deleting a protected video	702
8.12	Working with Axxon Next Through the Mobile Clients.....	702
9	Description of utilities.....	703
9.1	Axxon Next Tray Tool	703
9.2	Activation Utility	703
9.3	Axxon Support Tool	705
9.3.1	Purpose of the Support.exe Utility.....	705
9.3.2	Launching and Closing the Utility	705
9.3.3	Description of the Support.exe utility interface	706
9.3.4	The Processes Service.....	707
9.3.5	Collecting Data on the Configuration of Servers and Clients Using the Support	708
9.4	Log Management Utility	711
9.4.1	Starting and closing the utility	711
9.4.2	Configuring a Log Archive.....	711
9.4.3	Configuring Logging Levels	712

9.4.4	Set the size and maximum number of logs	713
9.4.5	Configuring Client RAM usage logging	714
9.5	Digital Signature Verification Utility	715
9.6	Backup and Restore Utility	717
9.6.1	Purpose of BackupTool.exe	717
9.6.2	Starting and quitting BackupTool.exe	717
9.6.3	Roll back the local configuration to a selected restore point	718
9.6.4	Roll back the global configuration to a selected restore point	720
9.6.5	Backing up a configuration	721
9.6.6	Restoring a configuration	724
9.6.7	Changing the Server Name	726
9.7	POS-terminal log collection utility	728
9.8	Console utility for working with archives	729
9.9	Network settings utility	731
10	Appendices	733
10.1	Appendix 1. Glossary	733
10.2	Appendix 2. Known issues in the Axxon Next Software Package	735
10.2.1	Possible Errors During Installation	735
10.2.1.1	Error starting NGP Host Service	735
10.2.1.2	Errors Connecting to the Postgres Database	735
10.2.1.3	Error installing Drivers Pack	736
10.2.1.4	Error installing DetectorPack	736
10.2.1.5	Window OS 10 installation error	736
10.2.1.6	An error occurred while installing on Windows with the language pack Norsk (bokmål)	737
10.2.1.7	Error uninstalling Axxon Next on systems with Videoinspector installed	737
10.2.2	Possible Errors During Start-Up	737
10.2.2.1	The Client cannot be connected to the Server	737
10.2.3	Possible Errors During Operation	737
10.2.3.1	All video cameras or archives stop working once the license maximum is reached	738
10.2.3.2	No signal from video cameras and failure to connect to other servers	738
10.2.3.3	Incorrect display of Client interface elements	738
10.2.3.4	Server error on Windows Server 2012	738
10.2.3.5	Emergency shutdown of the Client on Windows 8.1	738
10.2.3.6	Error creating new archives even when license restriction on total size is observed	739
10.2.3.7	The Axxon Next VMS operation along with Windows Defender software	739

10.2.3.8	Upper panel display problem.....	739
10.2.3.9	High CPU load during OpenGL software emulation.....	739
10.2.3.10	Performance of Axxon Next when working with NetLimiter 2.....	739
10.2.3.11	Exported videos' playback in Movies and TV application.....	739
10.3	Appendix 3. Assigning of the domain takes place when the Axxon Next server is installed ...	739
10.4	Appendix 4. Using Axxon Next with anti-virus software.....	740
10.4.1	NOD32.....	740
10.4.2	ESET Smart Security	740
10.4.3	AVG.....	740
10.4.4	DrWeb	740
10.4.5	McAfee SAAS.....	741
10.5	Appendix 5. Using CH VM-Desktop USB multifunction controllers with Axxon Next	741
10.6	Appendix 6. Hotkeys in Axxon Next.....	743
10.7	Appendix 7. Automated configuration backup and restore	746
10.8	Appendix 8. Configuring and operating the Axxon Next in Linux OS.....	747
10.8.1	Linux OS supported versions.....	747
10.8.2	Axxon Next limitations in Linux OS	747
10.8.3	Installing sudo.....	748
10.8.4	Installing the Axxon Next in Linux OS	748
10.8.4.1	Installing the Axxon Next Server in Linux OS.....	748
10.8.4.1.1	Installing from repository	748
10.8.4.1.2	Manual installation	749
10.8.4.2	Installing the Axxon Next Client in Linux OS.....	751
10.8.4.3	Configuration and log folders	753
10.8.4.4	Axxon Next Server launch using Docker	754
10.8.4.4.1	Docker installation.....	754
10.8.4.4.2	Specifics of Docker installation on Ubuntu	755
10.8.4.4.3	Creating the Axxon Next container	757
10.8.4.4.4	Working with the Axxon Next container	757
10.8.4.5	Updating the Axxon Next software in Linux OS.....	758
10.8.4.6	Uninstalling the Axxon Next software in Linux OS	758
10.8.5	Moving the Axxon Next configuration from Windows OS to Linux OS	758
10.8.6	Starting and stopping the Axxon Next Server in Linux OS.....	759
10.8.7	Archive creation features in Linux OS	759
10.8.7.1	Archive as a disk creation features in Linux OS.....	759

10.8.7.2	Archive as a file creation features in Linux OS.....	761
10.8.7.3	Features of archives with ext and xfs file systems.....	761
10.8.8	Axxon Next Server configuration change.....	762
10.8.9	Configuring the metadata storage in NAS on Linux OS	763
10.8.10	Configuring the Axxon Next Client logging parameters on Linux OS	764
10.8.11	License activation for the LP recognition detection in Linux OS.....	765
10.8.12	System data collection in Linux OS.....	765
10.9	Appendix 9. Using Axxon Next with NAT	766
10.9.1	Consolidating the Servers from different networks into Axxon domain.....	766
10.9.2	Connecting the Client to the Server behind NAT.....	768
10.9.3	Connecting the web and mobile Clients to the Server behind NAT	770
10.9.4	Audio transmission from the Client's microphone behind NAT to the Server's or camera's loudspeaker.....	771
10.10	Appendix 10. Creating system variable.....	772

1 User Guide. Introduction

On page:

- [General Information](#)
- [Purpose of the Document](#)
- [Purpose and functionality of Axxon Next](#)

1.1 General Information

No part of this document may be reproduced or transmitted in any form or by any means without the prior written permission of *AxxonSoft*.

The *Axxon Next* trademark is the property of *AxxonSoft*. All other trademarks included in this document are the property of their respective owners.

All information contained in this document is current as of the publication date. *AxxonSoft* reserves the right to change or update this document without the prior notification of or to any third party.

1.2 Purpose of the Document

This document, titled [User guide](#) contains the information necessary for building, implementing, and operating a security system based on *Axxon Next*.

The structure of this document enables the user to get acquainted with the software package and then, depending on the user's level of training, choose sections of interest for more detailed study. The chapters in this guide, whether they are informative or serve as a reference, have their own internal structure.

The chapters [Introduction](#) and [Description of the Software Package](#) are intended to generally acquaint the user with the technical features and functionality of the Axxon Next software package, as well as with the key stages of building a security system based on the software package.

Recommendations to the user/administrator for installing the software and configuring equipment are presented in detail in the chapter [Installing the Axxon Next Software Package](#). The chapter [Licensing of the software product](#) contains instructions on how to register a license to use the Axxon Next software package..

Startup and shutdown of the software package are described in the chapter [Launching and Closing the Axxon Next Software Package](#).

The chapter [Configuration of the Axxon Next Software Package](#) presents step-by-step instructions on configuring user-specific settings and activating the required functionality. This information is useful for system administrators as well as for operators with permissions to manage system settings.

Recommendations on configuring the user interface, working in various video surveillance modes, and utilizing the functional capabilities of the Axxon Next software package are presented in chapter [Working with the Axxon Next Software Package](#).

Chapter [Description of utilities](#) contains a description of additional software utilities employed when working with the software package.

The [Appendices](#) contains a glossary of the product's basic terms and definitions. It also lists all known issues that you may encounter while using Axxon Next.

1.3 Purpose and functionality of Axxon Next

The Axxon Next software package is a next-generation open-platform video management software (VMS). Security systems based on Axxon Next range from home security systems (for an apartment or house) to professional large-scale distributed security systems for small and mid-size businesses (hotels, automotive service centers, shops, parking structures, etc.).

Video and audio surveillance of guarded locations, video analysis, and rapid response to suspicious situations without operator involvement, and storage and export of obtained data are just a few of Axxon Next's many functions.

The Axxon Next software package enables the user to accomplish a wide spectrum of tasks, as it works both with digital equipment and with analog video cameras (through video capture cards), and also makes it possible to create a hybrid security system containing both kinds of equipment.

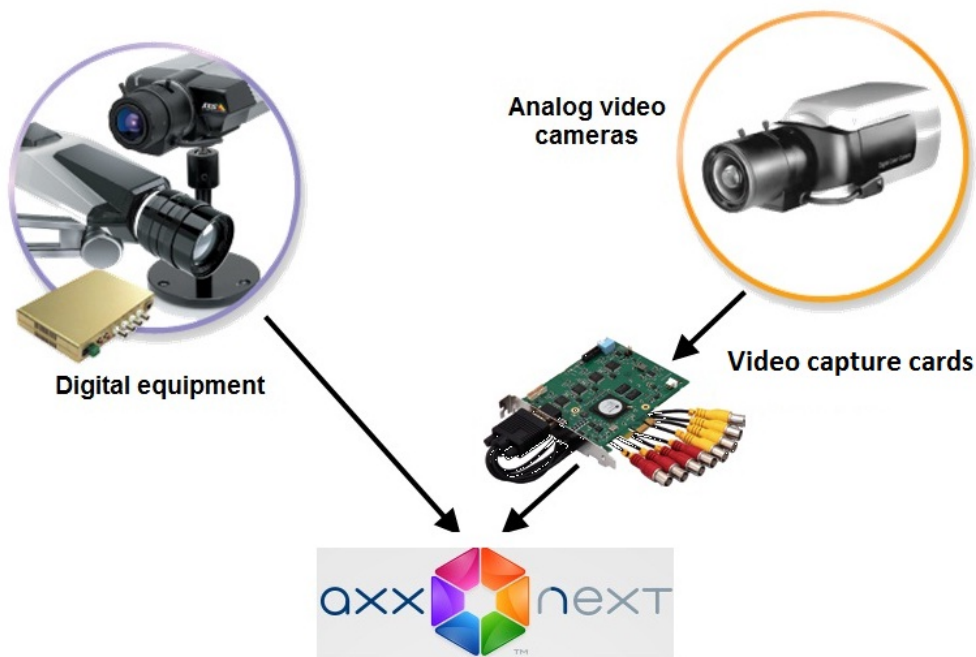

The modern and constantly expanding feature set of Axxon Next allows implementing new video surveillance functionality that increases the convenience and precision of protection at end-user sites.

2 Software Lifecycle Policy

On page:

- [Software Lifecycle Phases](#)
- [Software Technical Support](#)
- [Standard Period for Release of Software Updates](#)
- [Licensing Policy with Regard to Software Updates](#)

2.1 Software Lifecycle Phases

The software source code repository is divided into 3 branches:

- **trunk** - current changes;
- **stabilization** - preparation of a new release;
- **release** - the latest official release.

During the development process, all new software features are added to the **trunk** branch.

After reaching *Feature Complete* status, all changes from the **trunk** branch are moved to the **stabilization** branch.

From that time on, only software fixes that are critical for this version are added to the **stabilization** branch. These fixes are also duplicated in the **trunk** branch.

After the version stabilization is completed, all changes are moved from the **stabilization** branch to the **release** branch, and a new development phase begins.

2.2 Software Technical Support

After purchasing a license key, the Customer can receive full technical support throughout the key's validity period or until the end of the software lifecycle if the license is unlimited in time.

2.3 Standard Period for Release of Software Updates

Release	Standard period
Major release	1 – 1.5 years
Minor release	3 – 5 months
Bug and security fixes*	3 – 5 weeks

Major and minor releases are available on the [company's official website](#). Releases with bug and security fixes can be requested from [technical support](#).

* Software bugs can only be fixed in the latest official release.

2.4 Licensing Policy with Regard to Software Updates

- New software versions are fully compatible with the license keys of previous versions.
- After the software has been updated, all the features previously specified in the license key will be available in the new version.
- New software features that are subject to licensing will not be available until the license key is updated.

3 Description of the Software Package

3.1 Basic principles of building a security system based on the Axxon Next software package

Building a security system based on the Axxon Next software package includes the following recommended stages:

1. Selecting a configuration for the security system (with the help of professionals)
2. Building a separate local area network with restricted access
3. Calculating the sufficient bandwidth required for each segment of the local area network
4. Selecting and configuring the software and hardware platform on which the selected security system configuration will be implemented (selecting and configuring personal computers to act as servers and clients in accordance with the requirements, as referenced in the section titled [Implementation Requirements for the Axxon Next Software Package, Operating system requirements](#))
5. Selecting and connecting reliable equipment that is optimally suited for a specific security system (with the help of professionals)
6. Training personnel to work with the Axxon Next software package in accordance with the requirements (see the section titled [Requirements for Personnel Quantity and Qualifications](#)).

3.2 Axxon Next features: reference information

On page:

- [Micromodule architecture](#)
- [Support for IP cameras](#)
- [Support for analog cameras in Axxon Next](#)
- [Video and Audio Detection Tools](#)
- [Video archive](#)
- [Interactive 3D Map](#)
- [User Interface](#)
- [Face Recognition](#)
- [NumberPlate Recognition](#)
- [Receiving Events from External Systems](#)

The advanced features available in Axxon Next are continuously updated and extended.

Axxon Next offers virtually unlimited opportunities for system scaling, task-based customization, and reallocation of resources (based on changes in the number or quality of video and audio monitoring tasks) at end-user sites.

Video surveillance systems based on Axxon Next can scale infinitely: there are no restrictions on the number of video servers, workstations or video cameras.

Support for over 1500 models of IP cameras is included, as well as remote access from mobile devices and a web interface. The Axxon Next software package supports touchscreens.

3.2.1 Micromodule architecture

The micromodule architecture of Axxon Next video management software allows implementing different video management system functions as different operating system processes. Each function is the responsibility of a different micromodule; a dispatcher module monitors the functioning of the micromodules. If a function encounters an error and a process is quit unexpectedly, the dispatcher module automatically relaunches the corresponding micromodule. This does not affect the performance of other processes or the functioning of the VMS overall.

3.2.2 Support for IP cameras

Drivers Pack

IP camera support in Axxon Next is provided through the **Driver's Pack** Module specially developed by AxxonSoft and regularly updated to support new IP devices.

Driver's Pack allows adding support for new IP devices without having to wait for the release of new versions of Axxon Next and without reinstalling the entire system.

Multistreaming

Many of today's IP cameras can transmit two video streams with different video parameters and compressed in different codecs. Axxon Next supports Multistreaming i.e. receiving two streams from a camera simultaneously: high-quality and low-quality, which allows taking advantage of this feature of IP equipment to optimize the CPU load on the video server and the client workstation. .

GreenStream

The GreenStream feature saves bandwidth and client CPU resources. It automatically chooses a video stream from a camera to the server, and then to the client, depending on the resolution at which the video is currently displayed on the client.

Embedded video camera analytics

Axxon Next supports on-board detection embedded in video cameras. This means that when on-board detection tools are triggered, Axxon Next is notified and can use these events to drive system reactions. On-board detection does not burden the CPU of the video server and makes use of uncompressed video (completely bypassing the compressing/decompression process), and therefore provide extra stability in difficult conditions such as poor visibility.

360 degree camera support

360 degree camera support allows dewarping video from a fisheye camera or camera with an ImmerVision panomorphic lens to obtain several "normal" flat images with different frame aspect ratios for display on the client screen. One of the resulting virtual cameras can be a virtual PTZ unit.

ONVIF

AxxonSoft is a member of [ONVIF](#) (the Open Network Video Interface Forum), which work toward the development and promotion of international standards for network security and video surveillance system interfaces. ONVIF is supported in all versions of Drivers Pack starting with version 3.1.3.

RTSP support

Many IP cameras support multimedia streaming via RTSP. Axxon Next supports receiving such streams without requiring integration of the relevant camera via Drivers Pack.

3.2.3 Support for analog cameras in Axxon Next

Alongside IP cameras, Axxon Next allows you to use analog cameras in your video surveillance system. Analog cameras are more affordable and are well-suited for many installations without high video resolution requirements. In addition, Axxon Next allows creating hybrid systems that combine both analog and IP cameras.

3.2.4 Video and Audio Detection Tools

Axxon Next video management software incorporates a powerful system for analysis of video images. It includes the following video detection tools:

1. motion detection;
2. background change detection;
3. detection for loss of video quality;
4. abandoned objects detection;
5. detection of crossing a line in a given direction;
6. motion start detection;
7. motion stop detection;
8. loitering detection;
9. object appearance detection;

10. object disappearance detection

In addition to the video detection tools, Axxon Next has two audio detectors:

1. noise detection - is triggered by exceeding a certain threshold volume level;
2. silence detection - is triggered when the microphone signal disappears completely

Macros can be set to automatically run when a detection tool is triggered (on a per-detector basis). Multiple detection tools can be combined into complex conditional rules.

3.2.5 Video archive

SolidStore

SolidStore is a new file system for reliable video storage developed by AxxonSoft especially for storing video archives. By optimizing the reading/writing process we managed to achieve three important advantages:

- Enable high read/write speeds, approaching the physical access speed limit of the hard disk.
- Increase the service life of the hard disk.
- Solve the problem of data fragmentation.

TimeCompressor

Time Compressor allows the user to set a time range for video footage and get a short video clip of all moving objects in the scene. Objects and events captured at different times are displayed simultaneously in a condensed "video synopsis". Time Compressor is especially convenient for viewing large archives that feature a relatively small number of active objects.

Forensic Search in Archive

The Axxon Next video management software (VMS) utilizes VMDA – a database developed by AxxonSoft for indexing and storing descriptions of observed scenes. Along with video recording, this database allows archiving characteristics of all moving objects in the scene, and then uses these characteristics to perform quick searches of the video recordings (MomentQuest2 technology).

3.2.6 Interactive 3D Map

Interactive 3D Map superimposes camera locations on a site map and displays camera views in the same window. Cameras in the current layout are color-coded by current status. Operators can instantly pinpoint where a selected camera is located on the map and identify the corresponding location of interest.

Immersion Mode

When enabled, this mode overlays a translucent video viewing tile on the map; fixed objects in the field of view (furniture, doors, etc.) are combined with their depictions on the map. This allows easily seeing where a person or car is located and where it is going.

OpenStreetMap

OpenStreetMap support is available in Axxon Next. The site map is downloaded from the Internet and the user selects the necessary area and scale. Additional map data is downloaded in real time, if needed, when zooming in/out or scrolling.

Note

To work with OpenStreetMap maps in *Axxon Next*, you need to purchase an [OpenStreetMap](#) license.

Virtual PTZ cameras on the map

The Virtual PTZ Camera function becomes available when the map contains at least one fisheye camera. This function allows viewing video from a fisheye camera directly on the map. Click anywhere in the fisheye video shown in a layout cell to dewarp the source video, with digital zoom and click-to-focus.

3.2.7 User Interface

Editable camera layouts

Axxon Next allows you to create custom camera layouts. Layouts can be configured in any way the user wants and the aspect ratios of viewing tiles can be fine-tuned. Editable layouts efficiently fit different cameras with different aspect ratios on the same screen, as well as support display of dewarped fisheye camera footage.

Autozoom

Autozoom helps to monitor moving objects by automatically adjusting the level of digital zoom. Autozoom shows close-in video for parts of the frame that contain a moving object or objects and follows them as they move, just as a movie camera does when taking a close-up shot.

3.2.8 Face Recognition

Axxon Next includes an algorithm for recognizing human faces in a video frame and subsequent search for them in a video archive of several cameras. You can search by an uploaded photo or by an image of a person's face selected in a video archive frame. The system will return the video fragments from the archive where the searched person is present as search results.

3.2.9 NumberPlate Recognition

Axxon Next also includes an algorithm for recognizing vehicle number plates. The recognized number plates are saved to a database and matched with a video archive of several cameras. If a number plate contains similar characters, the system generates several hypotheses during the recognition. This increases the probability of a successful search for a particular number in a generated database.

3.2.10 Receiving Events from External Systems

Axxon Next includes a new feature set that is capable of receiving events from various external devices and systems — POS terminals, access control units, external software, etc.

3.3 Functions of the Distributed Security System

You can create a distributed system within an Axxon Domain on Axxon Next.

Axxon Domain – a selected group of computers on which the server configuration of the *Axxon Next* software package is installed. Linking the servers in a group makes it possible to set up interaction between them, thus organizing a distributed system.

Servers are interoperable only if they belong to the same Axxon domain. At the same time, each Server of the domain operates independently and has its own DB.

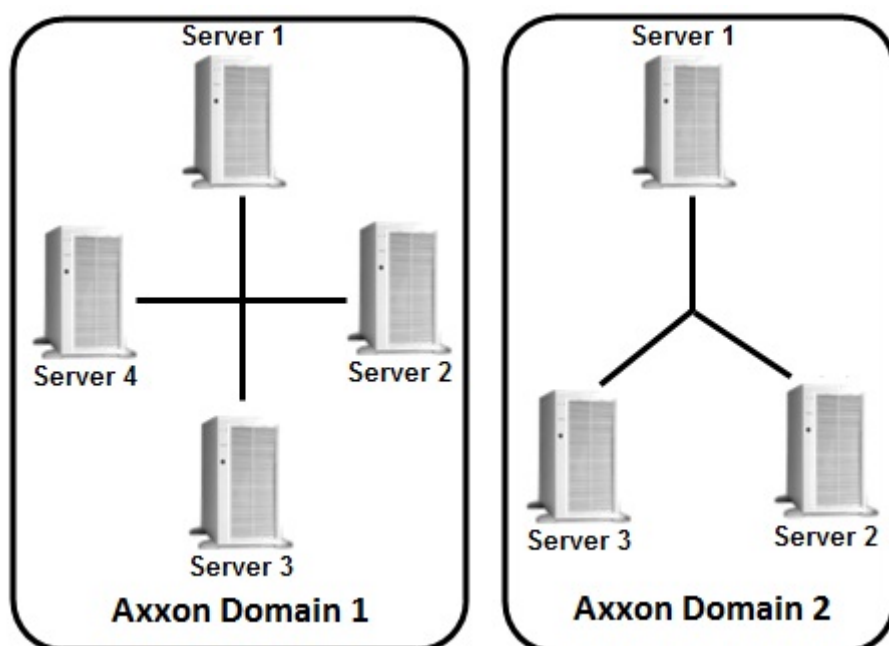

A distributed security system based on the Axxon Next software package offers the user the following functional capabilities:

1. Viewing and manual processing of video and audio data from several servers on one client
2. Controlling video cameras connected to various servers from one client
3. Configuring all servers of the distributed system on one client
4. Execution of automatic responses when detection tools are triggered (audio notification, triggering of relays, SMS and e-mail notification, etc.) within the distributed system.

Note

If a Server is not accessible by NetBiosName or some TCP and UDP ports are closed, it is possible to build a distributed security system on a virtual private network (VPN). For example, with the help of [OpenVPN](#). Detailed information on OpenVPN and examples of virtual private network configuration are given in the [official documentation](#).

Suppose, the Server relies on a defined port range (see [Installation](#)), and you want to set up a surveillance system based on several networks. You do not have to use VPN in that case. Use port forwarding instead.

Axxon Domain configuration is described in detail in the section titled [Configuring Axxon domains](#).

3.4 Network Topologies of the Axxon Next Software Package

Axxon Next supports both decentralized and star network topology.

The decentralized architecture better suits smaller systems.

The star architecture is more practical for creating large centrally monitored distributed systems where no local monitoring is required on remote sites.

Attention!

If your system is based on star topology, please take into account the following:

1. In a failover (see [General information about a failover system](#)) and non-failover systems, the Client must have access to all Servers (located centrally).
2. In a failover system, all Manager Servers must have access to each other (located centrally).

3.5 Specifications of the Axxon Next Software Package

Security systems based on the Axxon Next software package have the following primary characteristics.

Characteristics	Value
Number of servers in the distributed system	Unlimited
Number of clients which support simultaneous connection to the server	Unlimited
Number of servers which simultaneously transmit video images to a client	Unlimited
Number of video capture channels for "live video" processing on one Server	Unlimited
Number of detection tools per camera	Unlimited
Number of simultaneously processed signals coming from microphones	Unlimited

Characteristics	Value
Number of audio output channels (to speakers, headphones, etc.)	depends on the sound card used for playback
Number of PTZ devices used	Unlimited
Number of event sources (POS devices)	Unlimited
Number of user roles and users	Unlimited
Number of objects simultaneously tracked by the Object tracker	up to 25
Number of license plate recognition channels	Is determined by the license; there is no upper limit
Number of face recognition channels	Is determined by the license; there is no upper limit
Number of mobile clients or Web clients connections	Unlimited
Number of video walls	Unlimited
Number of maps	Unlimited
Analog video camera support	yes (through video capture cards)
IP device support	IP cameras and IP video servers This list is continuously expanding: support for new hardware is added through updates to Axxon Driver Pack
CPU support	32-bit (x86), 64-bit (x64)
Number of archives in the system	Unlimited
Maximum archive size	Unlimited
Video compression algorithms	MJPEG, MPEG-2, MPEG-4, MxPEG, H.264, H.264+, H.265, H.265+, Hik264 (only for x86)
Audio compression algorithms	PCM, ADPCM, g711, g726, aac, mp2
Available video image resolutions	resolutions supported by video cameras
Support for embedded video camera analytics	yes
Support for touchscreens	yes

3.6 Implementation Requirements for the Axxon Next Software Package

3.6.1 Limitations of the Axxon Next Software Package

When working with Axxon Next, the user must keep in mind the limitations that the developer has imposed on the system in order to ensure its operability.

No.	Limitation
1	<p>To work with Axxon Next software the following requirements for OpenGL are to be fulfilled:</p> <ol style="list-style-type: none"> 1. version 2.0 and higher; 2. Availability the ARB_vertex_program, GL_EXT_blend_func_separate, GL_ARB_framebuffer_object extensions. <p>Extensions availability can be checked using the OpenGL Extension Viewer program (download). This program also contains a large database of data on OpenGL support in video cards of various vendors.</p>
2	<p>Axxon Next Client cannot be started if the scale of all items on the screen (DPI) is over 100%. You may have issues with Axxon Next VMS if the screen resolution is set at 1280*720 pixels or lower.</p>
3	<p>The Server and Client must be of the same version. If not, Axxon Next VMS may have issues.</p>
4	<p>For correct operation of Axxon Next VMS, the OS should use the UTF-8 locale.</p>
5	<p>Downgrade to a previous version of Axxon Next is not allowed.</p>
6	<p>In one LAN, two Servers with the same name are not allowed, even if they belong to different Axxon domains</p>
7	<p>Maximum video frame rate in the Client is 50 fps.</p>
8	<p>To install Axxon Next, you must log in to Windows as an administrator.</p>
9	<p>For proper installation of Axxon Next, there should be no spaces at the beginning of the name of the folder which contains the installer</p>
10	<p>For correct and full-feature operation of <i>Axxon Next</i> software, the system must not limit network activity between all Servers and Clients.</p> <p>TCP and UDP access to these ports should be enabled. Otherwise, access to all ports should be allowed in the system</p>
11	<p>Time must be synchronized among all computers in the system (to be configured by the user).</p>
12	<p>If you have edge storage enabled in the system, synchronization between the server and the IP device is necessary (see The Embedded Storage object).</p> <p>Lack of synchronization may lead to bad DB entries of events detected on the edge device.</p>
13	<p>Before installing Axxon Next, make sure the video card drivers on the computer are fully up to date</p>
14	<p>NetBIOS name of a PC must match the following requirements:</p> <ul style="list-style-type: none"> • contains only Latin, numerical and "-" characters; • does not exceed 15 characters in length.
15	<p>The face detection tool requires a CPU supporting SSE4.2, FMA3 or AVX2.0 instruction set.</p>
16	<p>The Client cannot be started on a remote desktop through the Remote Desktop Connection utility built into Windows</p>

No.	Limitation
17	<p>If a computer is linked to an Active Directory domain, one of the following conditions must be met to enable disk access:</p> <ol style="list-style-type: none"> 1. Access control lists must contain only local or built-in groups and users. 2. Create an AxxonFileBrowser user in the domain and add it to the Users group (see Installation step 8). <p>This behavior is typical only of file systems that have access permissions (for example, NTFS).</p>

3.6.2 Operating system requirements

OS version	Supported edition	Note	
Windows 7 SP1 (x86, x64)	Starter (x86)	Restrictions, posed by OS edition (2GB of main memory, 1 physical processor, 1 monitor) - see http://www.microsoft.com	Stretch cards are supported in 32-bit version only
	Home Basic	Restrictions, posed by OS edition (1 physical processor) - see http://www.microsoft.com	
	Home Premium	Restrictions, posed by OS edition (1 physical processor) - see http://www.microsoft.com	
	Professional	OS edition, enabling to use all realized product features.	
	Enterprise	OS edition, enabling to use all realized product features.	
	Ultimate	OS edition, enabling to use all realized product features.	
Windows 8 (x86, x64)	Core	OS edition, enabling to use all realized product features.	
	Pro	OS edition, enabling to use all realized product features.	
	Enterprise	OS edition, enabling to use all realized product features.	
Windows Server 2012 (x64)	Foundation	Restrictions, posed by OS edition (1 physical processor)	Full Installation type is supported. Server Core Installation type is not supported
	Essentials	Restrictions, posed by OS edition (2 physical processors)	
	Standard	OS edition, enabling to use all realized product features.	
	Datacenter	OS edition, enabling to use all realized product features.	
Windows Server 2012 R2 (x64)	Essentials	Restrictions, posed by OS edition (2 physical processors)	Full Installation type is supported. Server Core Installation type is not supported

OS version	Supported edition	Note	
	Standard	OS edition, enabling to use all realized product features.	
	Datacenter	OS edition, enabling to use all realized product features.	
Windows Server 2016 (x64)	Essentials	Restrictions, posed by OS edition (2 physical processors)	Full Installation type is supported. Server Core Installation type is not supported
	Standard	OS edition, enabling to use all realized product features.	
	Datacenter	OS edition, enabling to use all realized product features.	
Windows 10 (x86, x64)	Pro	OS edition, enabling to use all realized product features.	
	Enterprise	OS edition, enabling to use all realized product features.	
	Education	OS edition, enabling to use all realized product features.	
	Home Edition	OS edition, enabling to use all realized product features.	
Windows 10 IoT (x86, x64)	Enterprise	OS edition, enabling to use all realized product features.	
Windows Server 2019 (x64)	Essentials	Restrictions, posed by OS edition (2 physical processors)	Full Installation type is supported. Server Core Installation type is not supported
	Standard	OS edition, enabling to use all realized product features.	
	Datacenter	OS edition, enabling to use all realized product features.	
Windows Server IoT 2019 (x64)	-	OS edition, enabling to use all realized product features.	Full Installation type is supported. Server Core Installation type is not supported
Debian 9 (x64) Debian 10 (x64)	-	Appendix 8. Configuring and operating the Axxon Next in Linux OS	

3.6.3 Disk storage subsystem requirements

On page:

- [General requirements](#)
- [Storage requirements](#)
 - [Minimum requirements](#)
 - [Size of archives](#)
 - [Database of the system log](#)
 - [Object trajectory database](#)
 - [Self-diagnostics service](#)

3.6.3.1 General requirements

For Axxon Next VMS operation, the disk subsystem must match the following requirements:

1. The device must have no less IOPS the Axxon Next VMS.

The Axxon Next VMS records video footage to archive volumes in 4MB blocks with a 10 second interval. If the most recent block is not full after 10 seconds, it will be filled up later.

Similarly, footage is played back in blocks (except for re-indexation, see the utility for archive management [Console utility for working with archives](#)).

This is how you can estimate the IOPS value for the Axxon Next VMS.

	If average bitrate per camera is less than 3.6 Mbps	If average bitrate per camera exceeds 3.6 Mbps
IOPS during archive recording Archive recording includes both data input (writing) and output (reading) operations	IOPS (writing) = $0,29 * N$ IOPS (reading) = $0,035 * M$	IOPS (writing) = $0,065 * M$ IOPS (reading) = $0,035 * M$
IOPS during archive playback Archive playback includes only output (reading) operations	IOPS (reading) = $0,035 * R * S$	
IOPS during simultaneous recording and playback	IOPS (writing) = $0,29 * N$ IOPS (reading) = $0,035 * M + 0,035 * R * S$	IOPS (writing) = $0,065 * M$ IOPS (reading) = $0,035 * M + 0,035 * R * S$
where <ul style="list-style-type: none"> • N is the number of camera channels being recorded; • M is the cumulative bitrate over all camera channels being recorded, in Mbps; • R is the cumulative bitrate over all camera channels being played back at normal speed (1x), in Mbps; • S is the playback speed. 		

2. If you use RAID storage, please specify write-back policy for writing to cash memory.

3.6.3.2 Storage requirements

Size of disk subsystem will be calculated on the basis of frame resolution and compression, rate of video signal frames per second, nuMber of cameras recording events to the hard drives and other recording parameters.

3.6.3.2.1 Minimum requirements

You need at least 10 GB of free disk space for Windows OS and 5 GB for Linux OS to install the *Axxon Next VMS* package in a **Server and Client** configuration.

Please see the storage calculations below, taking into account space needed for video footage, databases and system logs.

3.6.3.2.2 Size of archives

Size of disk subsystem can be calculated by formula:

Size of Disk subsystem (MB) = Time of storing an archive (days) x Cameras nuMber x Rate of recording (fps) x3,51 x Time of guaranteed recording from a camera (h / day) x Average frame size (KB),

where **Time of storing an archive** is the required time of storing an archive from one camera, days;

Cameras nuMber is the nuMber of cameras recording to the archive;

Rate of recording is the frame rate of recording to the archive, frames per second;

3,51 = (60 sec in min x 60 min in hour)/(1024 KB in MB) – is the coefficient used for KB/s-MB/h conversion,

Time of guaranteed recording from a camera is the nuMber of hours of guaranteed recording from one camera to the archive per day,

Average frame size is the average size of the camera frame, kilobytes.

Note

Average frame size for 640x480 resolution is:

Video codec	Average frame size
H.264	from 8 KB to 17 KB
MPEG4	from 8 KB to 35 KB
MJPEG	from 23 KB to 60 KB

Average frame size may vary over a wide range depending on the vendor, model and settings of the camera and video image complexity

Note

To calculate the frame size one can use the ratio, that while increasing vertical or horizontal resolution two times, the average frame size will be increased four times (this rule is a relative one and can be applied only to some cameras' models)

Examples of calculating a size of disk subsystem (without size of syslog database) are presented below.

Recording parameters	Calculating results
4 cameras with 25 fps and 640x480 resolution, guaranteed recording of 24 hours per day during one week	H.264: from 500 GB to 1 TB MPEG4: from 500 GB to 2 TB MJPEG: from 1.3 TB to 3.5 TB
16 cameras with 12 fps and 640x480 resolution, guaranteed recording of 12 hours per day during one week	H.264: from 500 GB to 1 TB MPEG4: from 500 GB to 2 TB MJPEG: from 1.3 TB to 3.5 TB
4 cameras with 25 fps and 1280x960 resolution, guaranteed recording of 24 hours per day during one week	H.264: from 2 TB to 4 TB MPEG4: from 2 TB to 8 TB MJPEG: from 5.3 TB to 14 TB

3.6.3.2.3 Database of the system log

The size of syslog database is to be taken into account when the size of disk subsystem is calculated. Estimated size of syslog database is calculated by formulas:

The capacity of the system log database (low detection activity) = $D * T * (0.01 \text{ GB / day})$;

The capacity of the system log database (average detection activity) = $D * T * (0.03 \text{ GB / day})$;

The capacity of the system log database (high detection activity) = $D * T * (0.12 \text{ GB / day})$;

where **D** is the total nuMber of detectors created in system,

T is the estimated duration of syslog storage, days.

3.6.3.2.4 Object trajectory database

The following formulas can help to determine the required disk size for the trajectory database:

Size of object trajectory database = $N \times T \times (0,5\text{GB} / \text{day})$ – sufficient disk size;

Size of object trajectory database = $N \times T \times (1\text{GB} / \text{day})$ – sufficient disk size plus reserve space;

Size of object trajectory database = $N \times T \times (5\text{GB} / \text{day})$ – sufficient disk size plus a large reserve.

N equals the nuMBER of video cameras in the system actively recording metadata; **T** equals the period of time (nuMBER of days) that metadata will be stored. By default, $T = 30$ days.

If you have less than 15 GB of free disk space, the Object Tracking DB is overwritten - new data records over the oldest data records.

3.6.3.2.5 Self-diagnostics service

When calculating disk subsystem capacity, please note that self-diagnostics service may generate up to 100 Mbytes of data per day.

The service's internal database retention time is limited to 7 days, and its size is limited to 512 Mbytes.

3.6.4 Hardware requirements

3.6.4.1 General hardware requirements

In the current implementation, *Axxon Next* software package is intended for use with IBM compatible PCs.

The required hardware configuration (motherboard, CPU, and hard disk) can be determined with the help of the [AxxonSoft calculator](#).

Attention!

If *Axxon Next* is installed on a computer with two processors, it is recommended to disable the Hyper-threading.

3.6.4.1.1 Minimal RAM requirements

Installation type	Minimal amount of RAM
Client	2GB
Server and Client, if the Client is not used	2GB
Server and Client	4GB

If you increase RAM speed by using memory with a higher frequency or using memory in dual-channel (or more) mode, you will reduce CPU usage and boost the performance of *Axxon Next*.

3.6.4.1.2 Minimum and recommended requirements for graphics cards

Minimum and recommended requirements for graphics cards are given below:

Recommended requirements	
	GPU: NVIDIA: GeForce 1030 1GB or higher IGP: Intel HD Graphics 560 or higher

Minimum requirements	GPU NVIDIA: GeForce 7300LE / GeForce 200 or higher (512MB) GPU AMD: Radeon HD 5000, Radeon HD 6000 or higher. IGP: Intel HD Graphics 530 OpenGL version 2.0 Availability the ARB_vertex_program , GL_EXT_blend_func_separate , GL_ARB_framebuffer_object extension for OpenGL
-----------------------------	--

Attention!

We recommend that you use the latest drivers for both Integrated (on-board) and Dedicated (shared) Graphics Cards .

Note

Extensions availability can be checked using the OpenGL Extension Viewer program ([download](#)).

3.6.4.2 Hardware requirements for neural analytics operation

The hardware requirements for the neural network-based analytics are:

1. For neural analytics operation, you may use CPUs, GPUs (NVIDIA discrete or Intel embedded), or VPUs ([Intel NCS](#) or Intel HDDL). Some NVIDIA SDK specific features allow the neural analytics to work on NVIDIA GPUs only under Windows Server 2019 or Windows 10.

Note

To connect an [Intel NCS](#), insert the device into a USB port and make sure that it is recognized by Windows OS as one of the following: Movidius, Myriad X, or VSC Loopback Device.

[Intel NCS](#) may be used with any PC that conforms to Axxon Next hardware requirements (see [Hardware requirements](#)).

Attention!

We do not recommend using more than one [Intel NCS](#) device per Server.

You can use several Intel HDDL devices on the Server if they have the same revision.

Attention!

For Intel HDDL to work correctly with AMD processors, pre-install the OpenVINO™ toolkit version 2019.3.379 (see https://docs.openvino toolkit.org/latest/openvino_docs_install_guides_installing_openvino_windows.html).

2. To use Intel CPU or GPU for analytics, please consider that the following processors are supported: Intel Core starting from 6th generation, Intel Xeon and Intel Pentium N4200/5, N3350/5, or N3450/5 with Intel HD Graphics <https://software.intel.com/en-us/openvino-toolkit/hardware>.
3. Video card: NVIDIA GeForce 1050 Ti or higher. Requirements:
 - a. at least 2 GB of memory;
 - b. Compute Capability 3.0 or higher.

Note

You can check the GPU's Compute Capability version on the [manufacturer's](#) website.

Attention!

If you use NVIDIA graphics cards, make sure to download the latest drivers from the [manufacturer's website](#).

When using a video card, a single neural network requires 500MB of video memory. For example: a "neural" fire detection tool and a "neural" smoke detection tool, both with unlimited number of channels, require a 1 GB graphics card or higher. You can use multiple video cards in your system.

Attention!

For correct operation of a detection tool, video image must match a specified set of requirements.

Requirements for each particular detection tool are listed in corresponding sections (see [Configuring detection tools](#)).

3.6.4.3 Hardware requirements for GPU based video decoding

If detection tools use GPU decoded video (see [Configuring detection tools](#)), make sure the following hardware requirements are met:

1. NVIDIA's graphics cards:
 - a. Compute Capability 3.0 and above.

Note

You can check the GPU's Compute Capability version on the [manufacturer's website](#)

- b. Support for CUDA 10.2 or higher.
 - c. Support for the required codec in NVDEC (see <https://developer.nvidia.com/video-encode-and-decode-gpu-support-matrix-new>).
2. For Intel embedded GPUs:
 - a. 6th generation CPU or higher.
 - b. Support for the required codec in Quick Sync Video.

3.6.4.4 Hardware requirements for Licence plate recognition (RR)

If license plate recognition (RR) runs on GPU, make sure the following requirements for devices are met:

1. GPU is an NVidia.
2. Compute Capability 3.1 or higher.

Note

You can check the GPU's Compute Capability version on the [manufacturer's website](#).

3. NVidia driver version is 450.36.06 or higher.

3.6.4.5 Hardware requirements for face detection

The face detection tool requires a CPU supporting SSE4.2, FMA3 or AVX2.0 instruction set.

If facial recognition runs on GPU, make sure the following hardware requirements are met:

1. The GPU is an NVIDIA.
2. Compute Capability 6.0 or higher.

Note

You can check the GPU's Compute Capability version on the [manufacturer's](#) website

3. NVidia driver version is 418.39 or higher.

3.6.4.6 Hardware requirements for Licence plate recognition (VT)

The VT automatic number plate recognition tool runs on the following processors: CPU, Intel GPU, VPU (IntelINCS).

You can find the list of supported devices on the [OpenVINO™ toolkit](#) page.

3.6.5 TCP/IP Network Bandwidth Requirements

Network bandwidth is a limiting factor in distributed system performance. The bulk of the information streamed over the network is video data. For example, the data flow (video stream) from remote cameras, such as used to monitor ATMs, is sent via communication channels.

Attention!

The minimum bit rate through the communication channel (network bandwidth consumption / goodput) for the Axxon Next VMS, should be at least **2 Mbit/s**.

To determine the required TCP/IP network bandwidth for video transmission from IP devices and some video capture cards, we recommend you to use [Axxon Platform Calculator](#) (check the **Total bitrate from ip devices (Mbit/s)** parameter).

3.6.6 BIOS configuration requirements

Axxon Next suite performance (namely, video decoding) is sensitive to CPU frequency. The higher the frequency, the better will be *Axxon Next* performance on this platform.

Modern computers have the power saving mode enabled in BIOS by default. Using this mode in multiprocessor systems results in incomplete CPU core utilization and decreases the performance of an input/output subsystem.

To increase *Axxon Next* suite performance, configure the computer BIOS as follows:

1. Disable all Enhanced Intel SpeedStep (EIST) technologies.
2. Disable power saving modes: select options providing maximum performance.
3. Disable green technologies such as Energy Saving, Turbo Boost, SmartThrottling.

Attention!

Different motherboard manufacturers use different names for these technologies. Therefore, for every particular motherboard model you must find the technology name in the documentation for this model.

3.6.7 Running Axxon Next VMS in Virtual Machines

The *Axxon Next VMS* can be run in the following virtual machines:

- VirtualBox (all versions);
- VMWare (all versions);
- HyperV (all versions).

Attention!

To run the Client, 3D acceleration must be enabled.



Note

The operating system in a virtual machine must meet the general requirements.

If you use VirtualBox on Windows 7 SP1 and in HyperV, you won't be able to access a Guardant USB key from the guest system.

In HyperV, you can use third-party utilities (for example, [USB Network Gate](#)) instead.

3.7 Interface of the Axon Next Software Package

Axon Next Client has 2 basic interfaces: Layouts  and Settings .

To switch the two, click the tabs at the top of the screen.

Note

If there are no cameras in VMS, the  tab is not available.

Attention!

You can configure access to any given tab and buttons in the top panel individually for each user role (see [Configuring user permissions](#)).

When you are configuring VMS, the top panel shows tabs with different groups of settings, the button for switching to the system log, current user name and the Quit button.

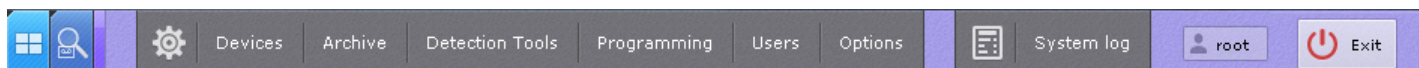

When you select **Server** or any child object in the **Hardware**, **Archive** or **Detection Tools** tabs, the upper panel shows the current CPU and network load.

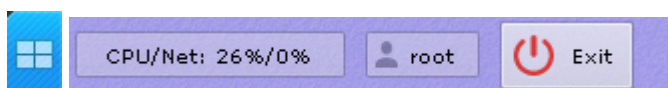

In the Layouts interface in the upper pane, you see the following elements:

1. [Camera search panel](#).
2. System time.
3. Context menu.
4. Video surveillance mode selection tabs.
5. [Video wall management panel](#).
6. [Monitor management panel](#).
7. [Layouts panel](#).
8. [Macro menu](#).
9. [Layout scaling buttons](#).



In the Layouts and Search interface, you can hide the top panel. To do this, click the  button in the top right corner. To show the top panel, hover over it with the pointer.

Note

To pin the top panel, click the  button.

In Full Screen (see [Configuring the Client screen mode \(full screen or window\)](#)), to collapse the client window, click the  button.

3.8 Ports used by the Axxon Next Software Package

Ports	Change able	Installation type	Process	Open the port*
20040 20041 20108	No	Server and Client Failover Server and Client	Self-diagnostics service	Not required
20109	Yes	Server and Client Failover Server and Client	NativeBL Core (see Configuring the Server ports)	Required
20110	No	Server and Client Failover Server and Client	PostgreSQL database	Required
20111-20210	Yes	Server and Client Failover Server and Client	Server (see Installation)	Required
80 (Windows) 8000 (Linux)	Yes	Server and Client Failover Server and Client	Web server (see Configuring the web server)	If necessary + HTTPS port 443
554 (Windows) 50554 (Linux)	Yes	Server and Client Failover Server and Client	RTSP server (see Configuring an RTSP Server)	Not required
8888	No	Server and Client Failover Server and Client Client	Client HTTP API (see Client HTTP API)	Not required
4000 4646-4648 8300-8302 8500 8600	No	Failover Server and Client	Failover (see Ports used by the failover system)	Required

* in a configuration including several Servers in firewalled LANs, or port forwarding on the router under NAT environment.

3.9 Requirements for Personnel Quantity and Qualifications

The following roles have been defined for operating the Axxon Next software package:

1. Security system administrator
2. Security system operator

In special cases, one person can perform the functions of both the administrator and the operator.

The main duties of the administrator are to:

1. Update, configure, and monitor the operability of the security system's hardware
2. Install, update, configure, and monitor the operability of basic and system software
3. Install, configure, and monitor software applications
4. Manage user accounts (this duty can be carried out by a user entrusted with system administrator permissions).

The administrator must have the skills necessary for network configuration, including routing and firewall, as well as NetBIOS, DNS, and NTP network services.

Besides, the administrator must have high qualifications and practical experience installing, configuring, and administering the software and hardware employed in the software package.

The software package is structured so that all accessible functionality can be managed by one administrator or administration responsibilities can be divided among several users.

The main duties of an operator are to:

1. Work with the software's GUI (graphical user interface)
2. Optimize the performance of the personal computer to carry out tasks using the functionality provided in the software package
3. Create roles and users in the system (if the user has been granted the appropriate permissions)

The system operator must have experience with, and be a qualified user of, PCs running Microsoft Windows and must be able to easily perform basic operations.

4 Installing the Axxon Next Software Package

4.1 Installing equipment

4.1.1 Types of Devices Used

An IP device is the source of the video signal (video data) for the Axxon Next software.

Note

You can connect analog video cameras to Axxon Next via video capture cards, which the software defines as IP devices

The following types of equipment are IP video and audio surveillance devices:

1. IP video cameras
2. Various types of IP video servers

IP video servers which use analog video cameras directly connected to them, digitize the analog video signal, and transmit it to users via TCP/IP. When working with analog video cameras connected to IP video servers, users can utilize the same video image viewing and transmission functions as with IP video cameras.

4.1.2 Connecting IP Devices

To work with IP devices, you need to connect the Axxon Next server to the local network where the required IP devices are enabled.

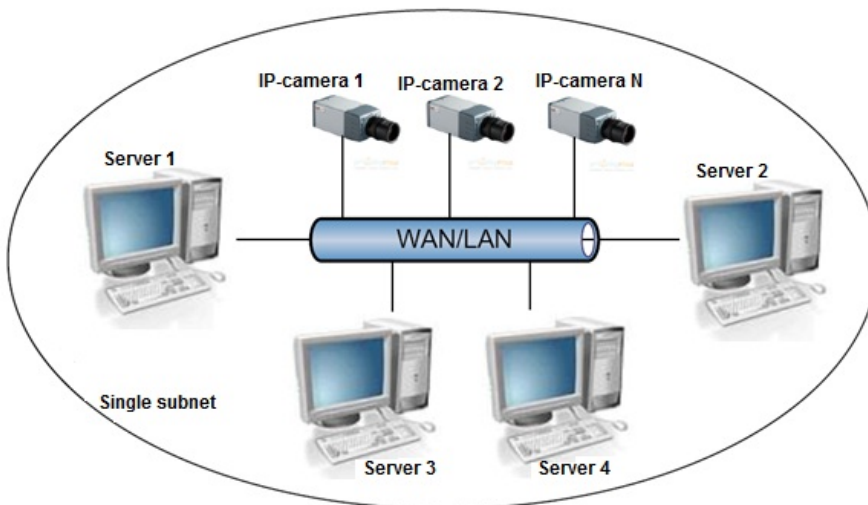

To ensure support for IP devices on an external network:

- The IP devices must have an external static IP address.
- The necessary ports on the network equipment must be opened.

Attention!

If these requirements are met, IP devices should be properly handled. However, correct functioning is not guaranteed

Based on the video signal coming in from the IP device, an assessment is made of the guarded location and the system responds to events registered for that location. The content and quality of the obtained video information depends on how the IP device is installed and configured. There are a number of rules that must be followed to obtain a high-quality video signal. In particular, high-quality peripheral equipment (hubs/routers) must be used; we advise against use of Home and Office-class devices, which are not intended for use in such security systems.

Note

IP devices connected to such equipment will transmit a video stream with an unacceptably long delay (from 1.5 to 3 seconds per frame)

Detailed information about creating a local network and connecting IP equipment to it is presented in the corresponding reference documents.

4.1.3 Configuring IP Devices in Windows

IP devices can be configured in Windows by using the following software:

1. Software included with the IP device This software is used to accomplish the following tasks:
 - a. Searching for network devices connected to the local network
 - b. Preliminary IP address assignment (without account of routing)

Attention!

Without assigning preliminary IP addresses to the devices, it is not possible to access their Web interface

2. Web interface of the IP device. This interface is used to accomplish the following tasks:
 - a. Configuring the IP devices with consideration for routing
 - b. Configuring modes for the IP devices to work with video and audio signals
 - c. Viewing video images coming in from IP devices in standard Web browser mode

Configuration of IP devices in Windows is described in detail in the official reference documentation for the respective devices.

4.1.4 Video capture cards pins

4.1.4.1 WS-216 video capture card pins

WS-216 video capture card has two external DVI-I pins. Video and audio connection is performed with the help of DVI-I/BNC and DVI-I/RCA stubs correspondingly. Simultaneous connection of up to 8 cameras and up to 8 sound sources to one external pin of WS-216 video capture card is possible. The Watchdog cable is connected to the J1 pin. DI/DO card is connected to the J2 pin.

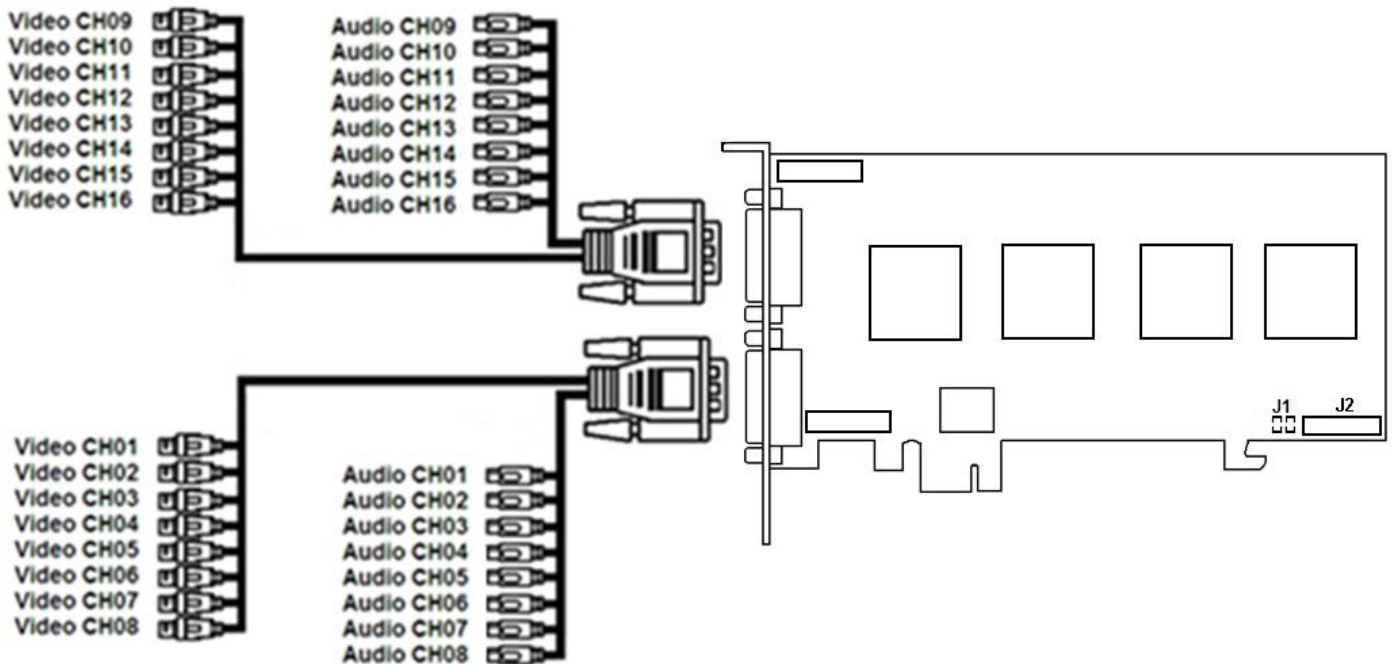

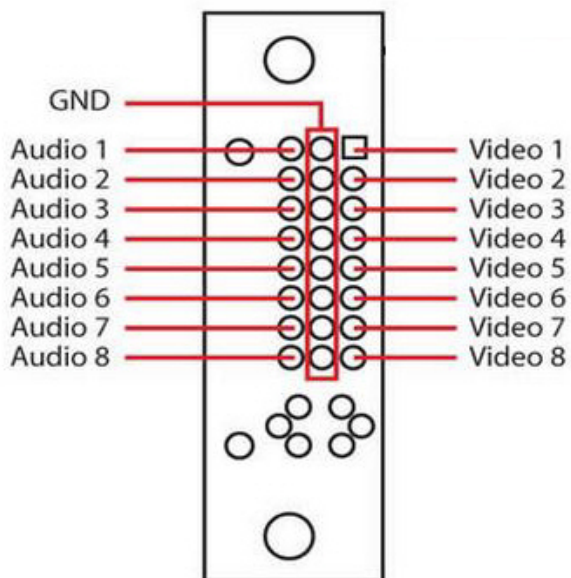
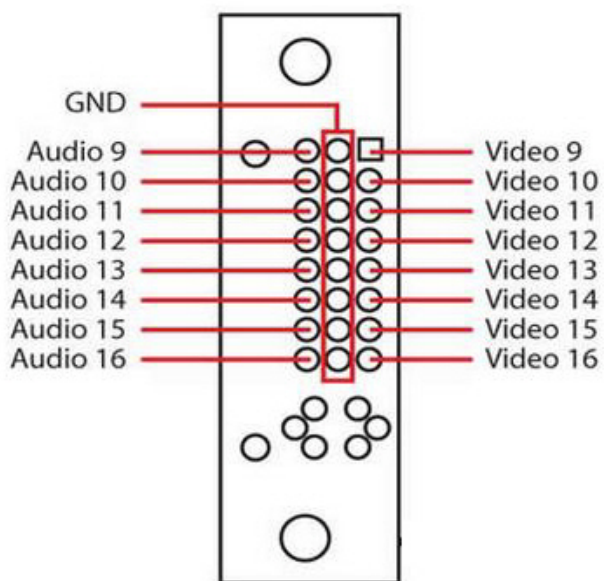

4.2 Installation the Axxon Next Software Package

4.2.1 Installation

To install Axxon Next, regardless of the type of installation, you must perform the following steps:

1. Insert the Axxon Next installation disc into the CD drive, or unpack the archive with installer package.

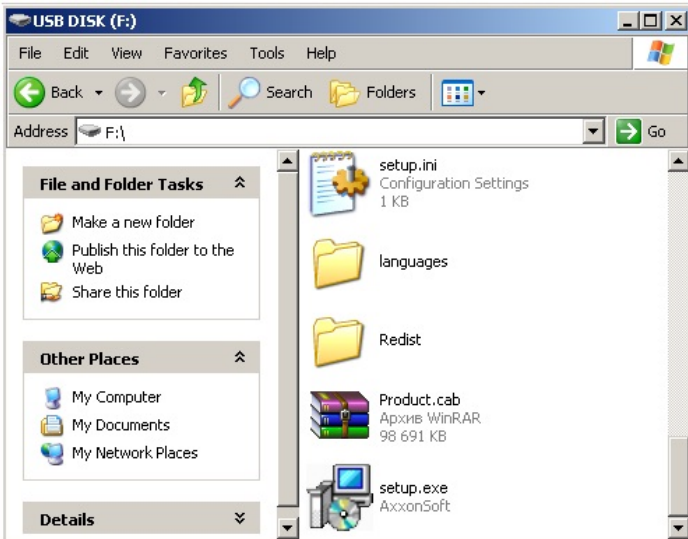

2. Run the Setup.exe file.

Note

If you cannot run the installation files downloaded from Internet, do as follows : allow running programs and unsafe files in Windows OS.

3. In the dialog box, choose the desired language from the list and click **OK**

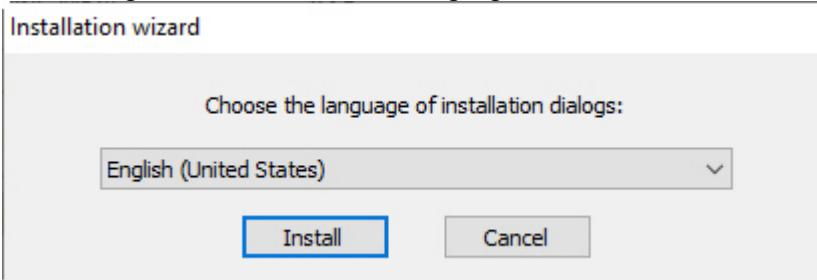

4. Select the Axxon Next software installation type in the dialog box by clicking the appropriate option button:
 - a. **Client** – This type of installation is used for installing the software's user interfaces, which enable any user to connect to any server within a single security system and to perform administration/management/monitoring of a guarded location based on the permissions granted by the administrator.
 - b. **Server and Client** — installs Client and Server services. *Axxon Next Server*:
 - i. interacts with devices (cameras, microphones, inputs, outputs, etc.) that constitute a security system;
 - ii. writes video footage to archives on system disks; interacts with archives on NAS;
 - iii. hosts VMDA database;
 - iv. employs detection tools to analyze live video;
 - v. keeps configurations of the security system, user settings, custom layouts, macros, etc.
 - c. **Failover Server and Client**— installs Client and Server services enhanced with the Failover capability. In emergency (power outage, network problems), the Failover technology restores the server configuration on another server. Please refer to the section titled [Configuring Failover VMS](#) for details on how to install VMS with the

Failover capability.

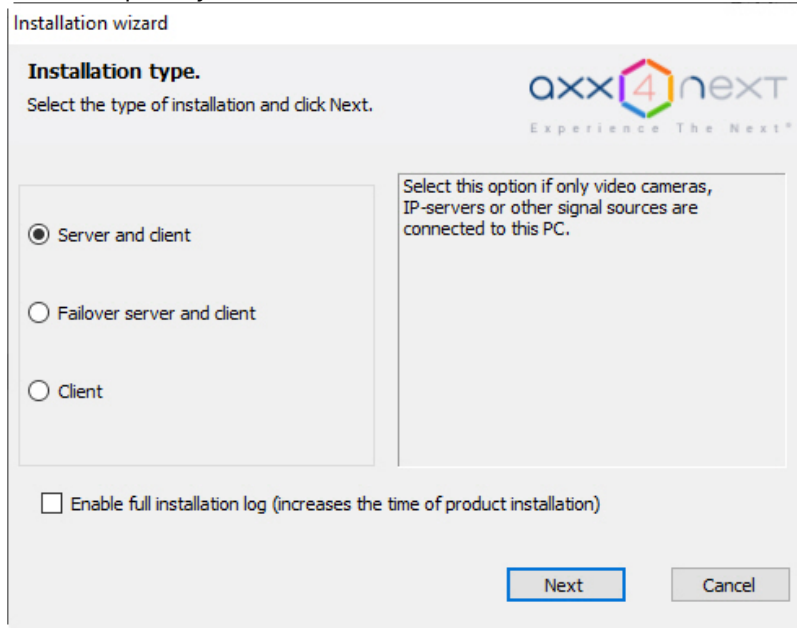

Note

We offer a separate software package containing only the Axxon Next Client. To obtain it, contact our [technical support](#).

This package is intended only for Client updates; you cannot install it on a PC where no *Axxon Next* software was previously installed.

5. To record all installation-related events to a log file, select the **Enable full installation log** check box.
6. Click the **Next** button.

A dialog box prompts you to select the components for installation.

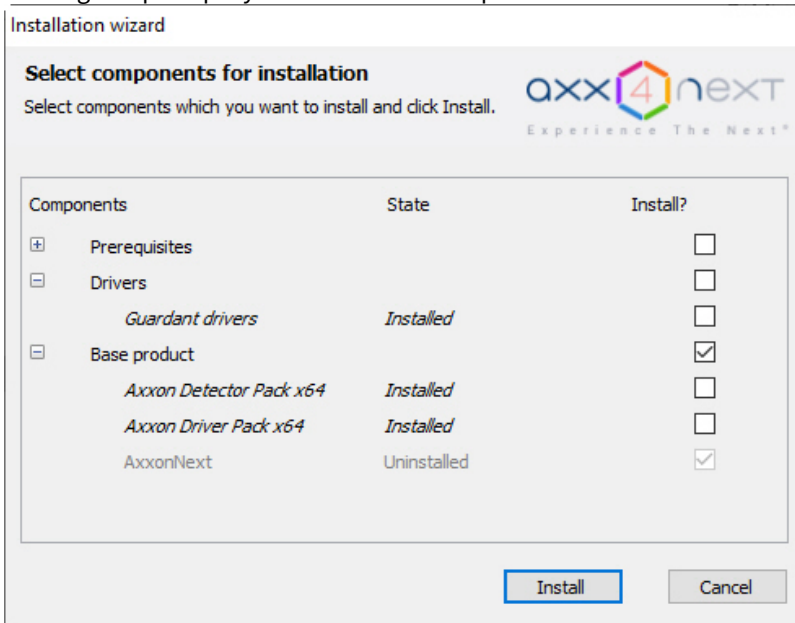

7. Select check boxes for the components that you want to install. We recommend installing all components.

8. Click the **Install** button. All selected components will be installed. The installation process may take considerable time.

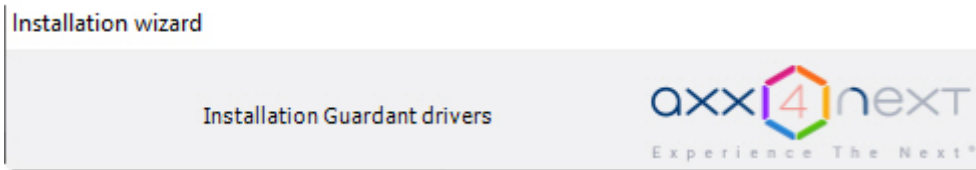

Attention!

Starting from Axxon Driver Pack 3.51, this driver package requires the Windows update KB2999226 to be installed. If this update is missing, you will see a warning. To continue installation, download the upgrade from the official Microsoft website.

Two different versions of the Windows KB2999226 update are available for 32 and 64 bit system versions.

Note

The following required software is installed, if necessary:

- 1) PostgreSQL 10.8.0 server database If an older version of PostgreSQL is installed, it is updated to version 10.8.0. A new log database is automatically created (name: ngp, user name: ngp, password: ngp).
- 2) .NET Framework 2.0, .NET Framework 3.5 SP1 and .NET Framework 4.0
- 3) Acrobat Reader, which is necessary for exporting in PDF format and printing freeze frames (see [Frame export](#)).
- 4) VLC Player The VideoLan folder, in the Axxon Next installation folder, contains the file VLC.exe, which is a version of the VLC Player that can be run from any connected disk without installation. This file can be used to view exported archive video.

9. After installation of the required software and drivers, preparation begins for Axxon Next installation.

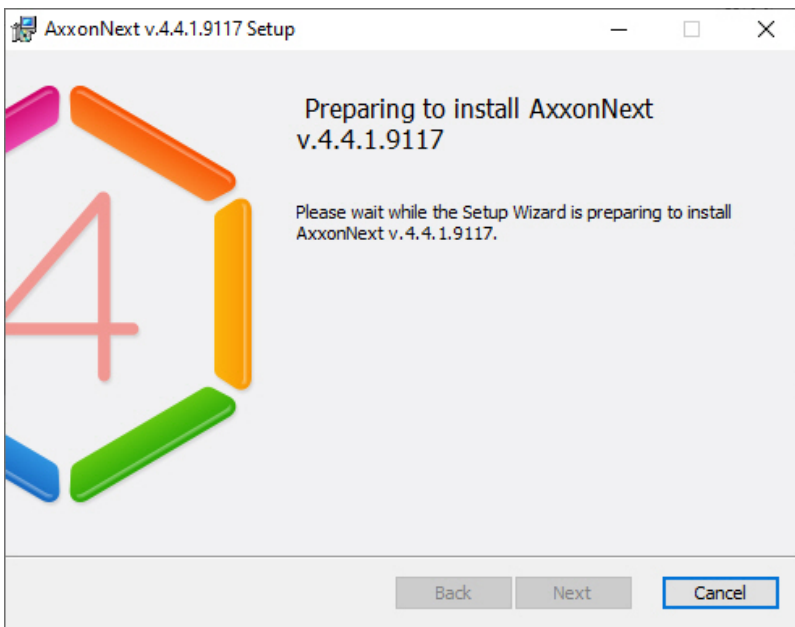

10. Click **Next** on the setup wizard's welcome screen.

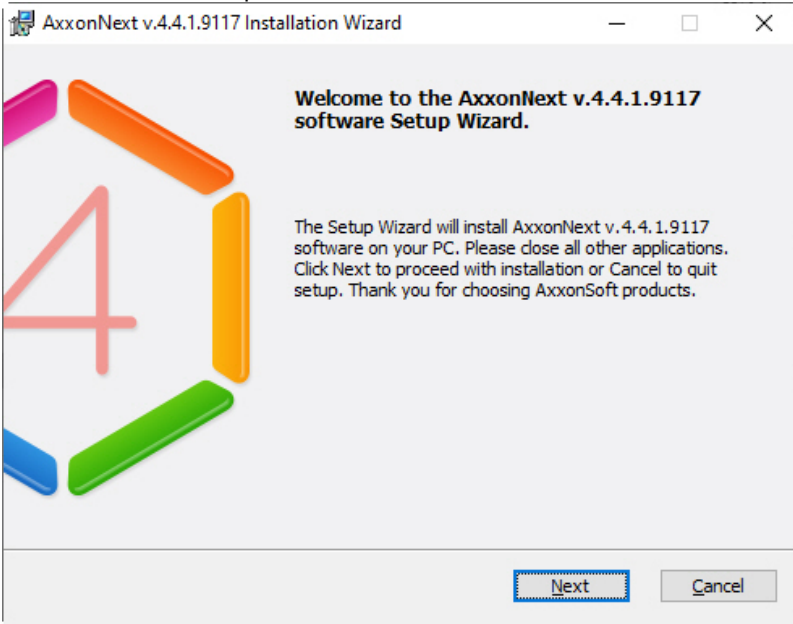

11. To proceed with installation, accept the terms of the license agreement by selecting the radio button next to **I accept the terms of the License Agreement** and click **Next**.

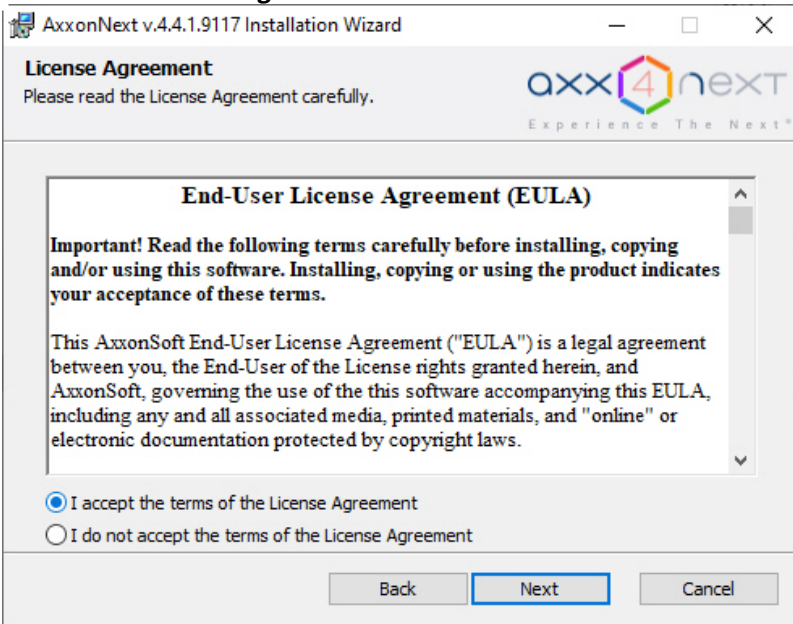

12. Indicate the destination folders for installation of Axxon Next components and click **Next**.

Attention!

The installation path for Axxon Next and its databases must contain only Latin letters and numbers.

Note

By default, the software will be installed to the directory C:\Program Files\AxxonSoft\AxxonNext\.

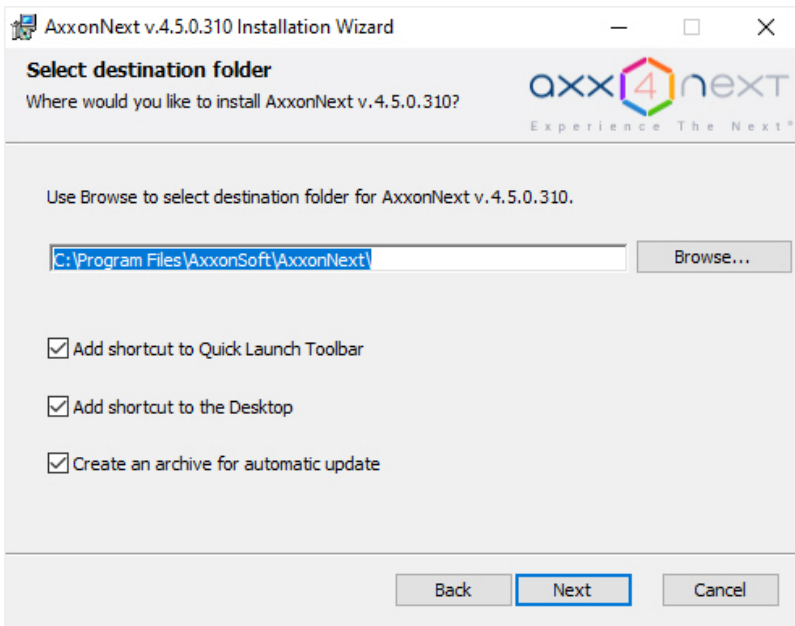

13. By default, shortcuts are added to both quick launch bar and desktop. De-select the corresponding checkboxes if it's not required.
14. Upon connection to a Server, the Client may be automatically updated. De-select the **Create an archive for automatic update** checkbox if it's not required. In this case, you can save Axxon Next VMS installation time but the Clients will not be automatically updated upon their connection to the Server.
15. By default, the Axxon Next Server's name is identical to the PC's. If the PC name contains forbidden symbols, you have to set an appropriate name for the Server according to recommendations, and click **Next**.

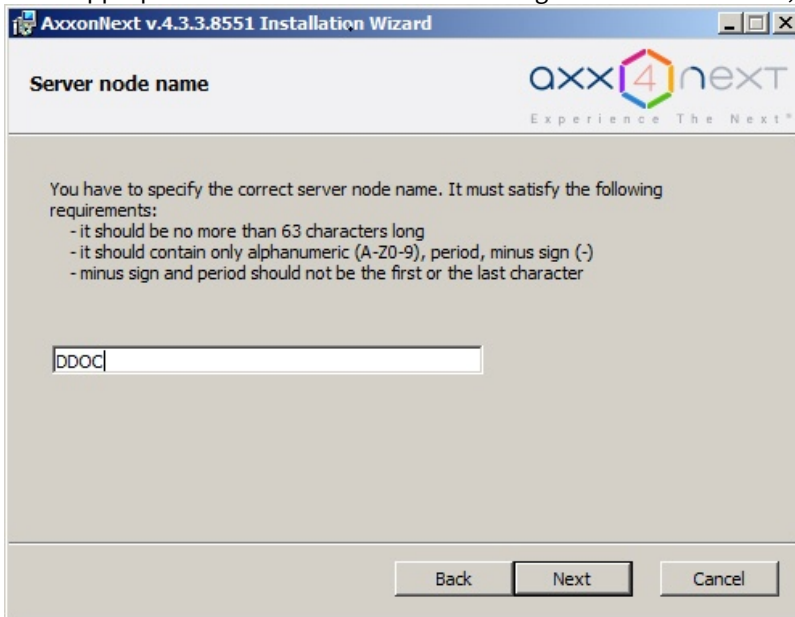

16. In the window that opens, select an installation method and click the **Next** button.
 If the **Custom** installation method is selected, you can perform advanced configuration of the installation of Axxon Next.
 If the **Standard** installation method is selected, you are prompted to select an Axxon domain (Step 20). Default values will

be used for other steps/settings.

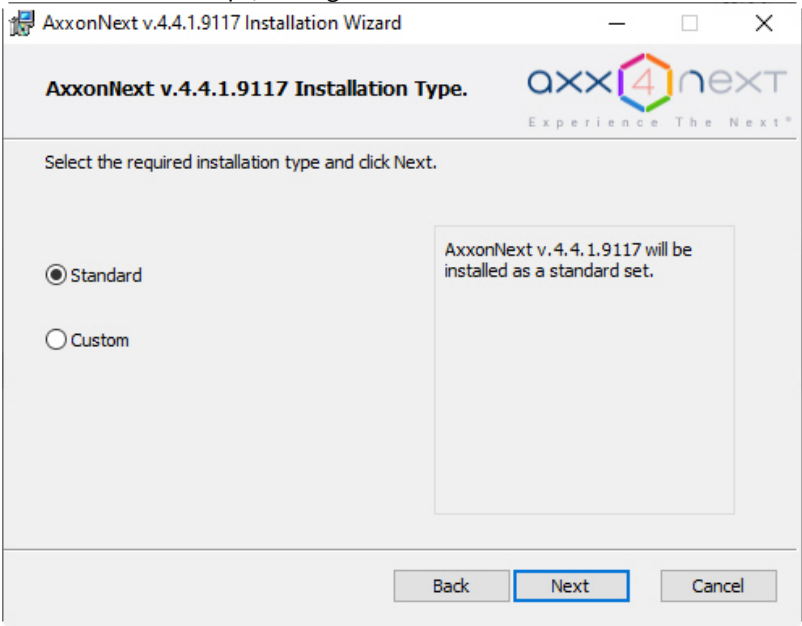

17. Select a user account in the file browser:

Note

The file browser helps to navigate through the Server's file system (such as when choosing disks for log volumes). The user account for the Windows file browser will be created with administrator privileges.

Attention!

After installation of Axxon Next, make sure that a file browser account has been created in Windows and belongs to the Administrators group.

- a. Create a new account; the default name selected will be AxxonFileBrowser.
- b. Select the LocalSystem account.
- c. Specify username and password for new or already existing user.

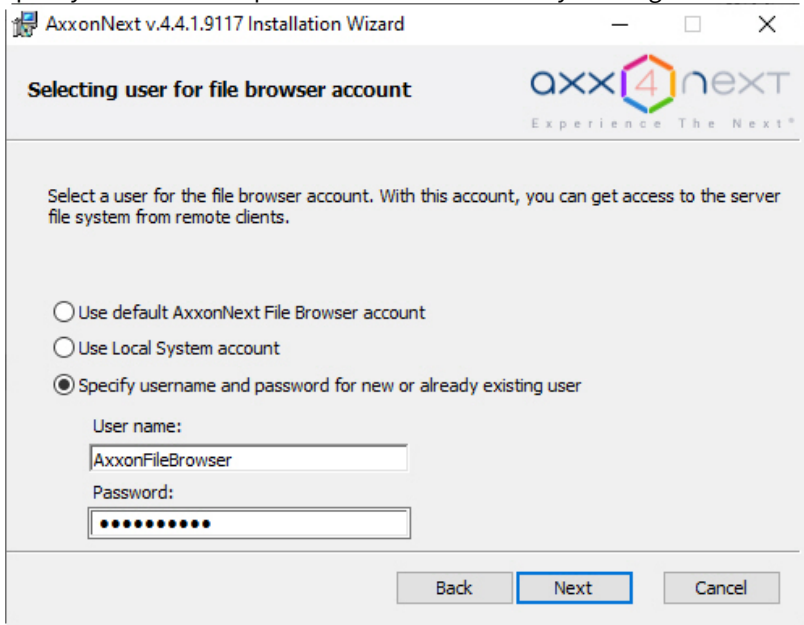

18. Select a folder for storing the files and folders of the Axxon Next configuration.

Note

By default, the files and folders of the configuration are stored at the following path:
 \ProgramData\AxxonSoft\AxxonNext\

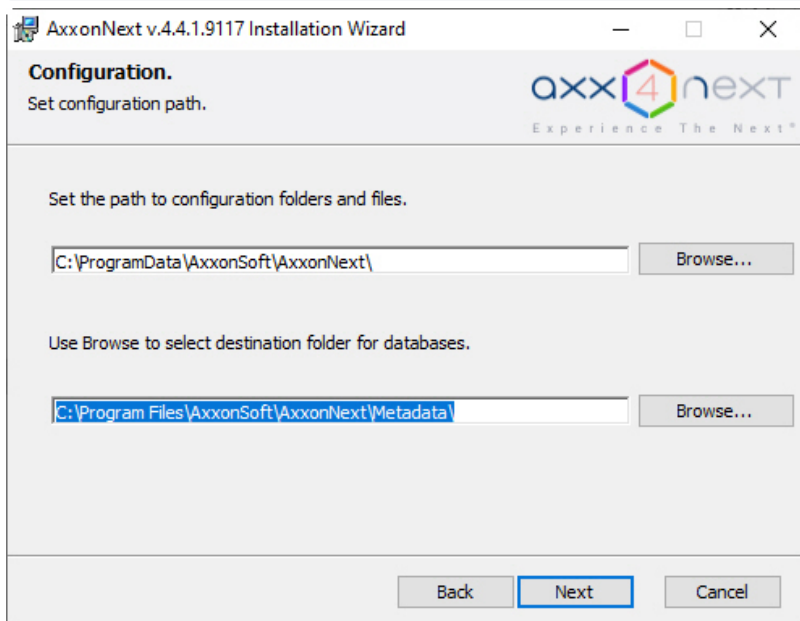

19. Select a folder for storing Axxon Next databases: the log database and object trajectory database.

Attention!

The installation path for Axxon Next and its databases must contain only Latin letters and numbers.

Attention!

You are advised to place the log database and object trajectory database on a disk that has sufficient space. If you will be using only a log database, the disk capacity must be at least 5% larger than the archive size. If you will also be using a trajectory database, the disk must be at least 15% larger than the archive.

The following formulas can help to determine the required disk size for the trajectory database:

Size of object trajectory database = $N \times T \times (0,5\text{GB} / \text{day})$ – sufficient disk size;

Size of object trajectory database = $N \times T \times (1\text{GB} / \text{day})$ – sufficient disk size plus reserve space;

Size of object trajectory database = $N \times T \times (5\text{GB} / \text{day})$ – sufficient disk size plus a large reserve.

N equals the number of video cameras in the system actively recording metadata; **T** equals the period of time (number of days) that metadata will be stored. By default, T = 30 days.

If you have less than 15 GB of free disk space, the Object Tracking DB is overwritten - new data records over the oldest data records.

Note

By default, the log database and the object trajectory database will be placed in: C:\Program Files\AxxonSoft\Axxon Next\Metadata (in the pg_tablespace and vmda_db subdirectories, respectively).

In the future, the metadata database can reside on network storage (see [Configuring storage of the system log and metadata](#))

20. Click the **Next** button.
21. Specify the range of ports to be used for the Server. To do so, specify the lower end of the range, as well as the number of ports. This feature guarantees that any server process will use only ports from the allowed range for its needs. The minimum possible number of ports is 20.

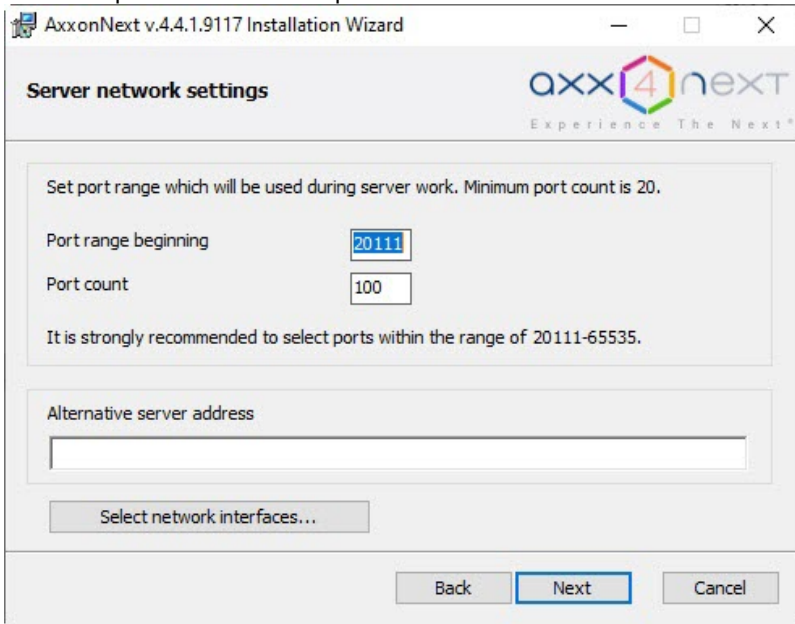

Note

The number of ports that you select affects the scalability of the system. Keep the following in mind when specifying the number of ports:

After the Server is installed, it occupies **10 ports**, including one for sending e-mails (via SMTP) or text messages (via SMS).

In a 64-bit configuration, **4 ports** are required for any number of IP devices. In a 32-bit configuration, **4 ports** are required for each **32 cameras**.

Each archive requires **1 port**.

1 port is required for viewing Video Footage through the Web Client.

2 ports are required for each decoded video stream on the currently opened layout in the Web Client.

2 ports are required for any number of loudspeakers in the system.

1 port is required for recording metadata into the DB.

2 ports are required for service detection tools operation.

2 ports are required for scene analytics detection tools operation.

2 ports are required for neuro tracker operation.

2 ports are required for neural counter operation.

Attention! The Failover Server and Client installation type uses 9 base ports and preset port ranges for each node (see [Ports used by the failover system](#)).

22. Set the outside local address for a Server behind the [NAT](#).
23. To restrict visibility of Servers on particular networks in the list of Servers during Axxon Next setup:
 - a. Click the button **Select network interfaces...** The **Network interfaces** window opens.

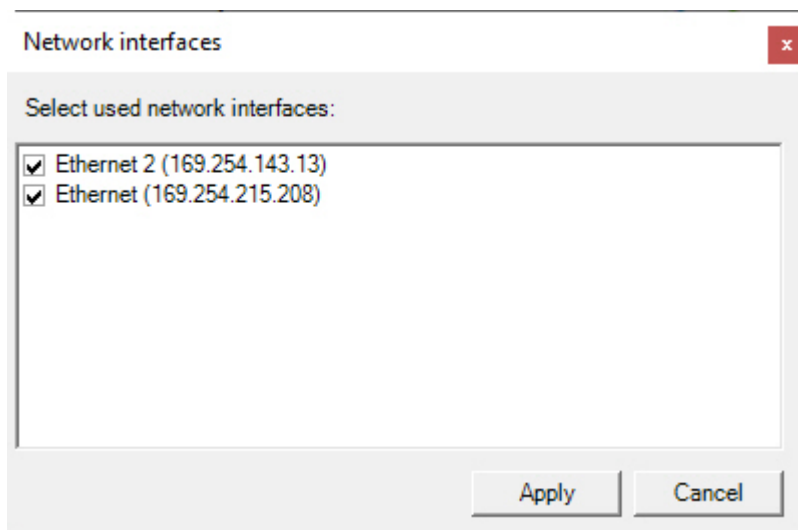

- b. By default, use of all available network interfaces on the Server is allowed, meaning that Servers on the relevant networks will be visible in the list. If you do not want for the Servers on the networks of certain network interfaces to be visible in the list, clear the relevant check boxes.

Note

Depending on the network topology, it will still be possible to reach the Servers manually (if broadcasting is allowed between the network segments).

- c. Click the **Apply** button.

24. Click the **Next** button.

25. Create a new Axxon Domain with the name **Default** (for the definition of an Axxon Domain see [Appendix 1. Glossary](#)). If you want to add the computer to an Axxon Domain at a later time, select **Server will be manually added to already existing Axxon-domain later**. Click the **Next** button

Note

When reinstalling *Axxon Next*, you have the option of using the previous Axxon Domain (select **Use existing configuration**)

Note

Using the same Axxon Domain name does not guarantee that the Servers will be in the same Axxon Domain. To place all Servers into one Axxon Domain, you must use the Axxon Next interface to add each Server to the necessary Axxon Domain. Axxon Domain configuration is described in detail in the section titled [Configuring Axxon domains](#).

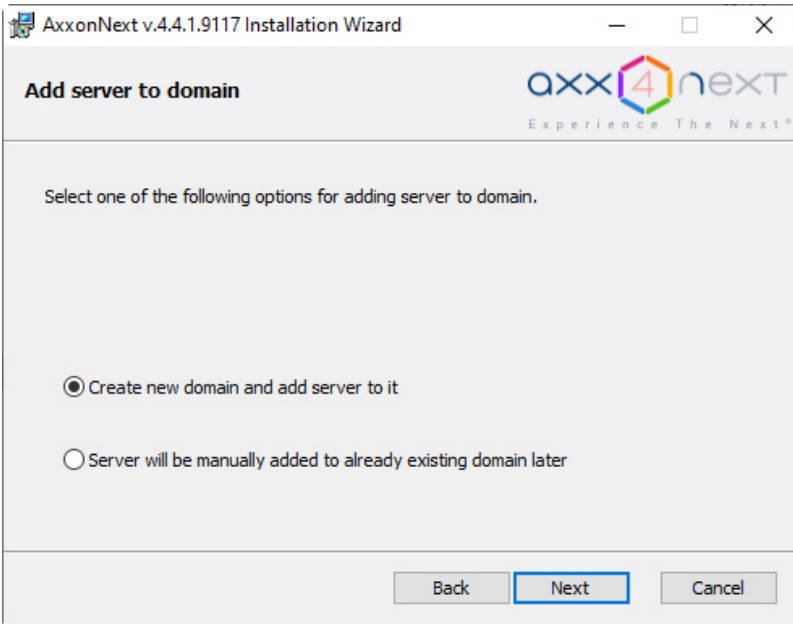

26. A dialog box then appears, showing the installation parameters corresponding to the selected type of installation.

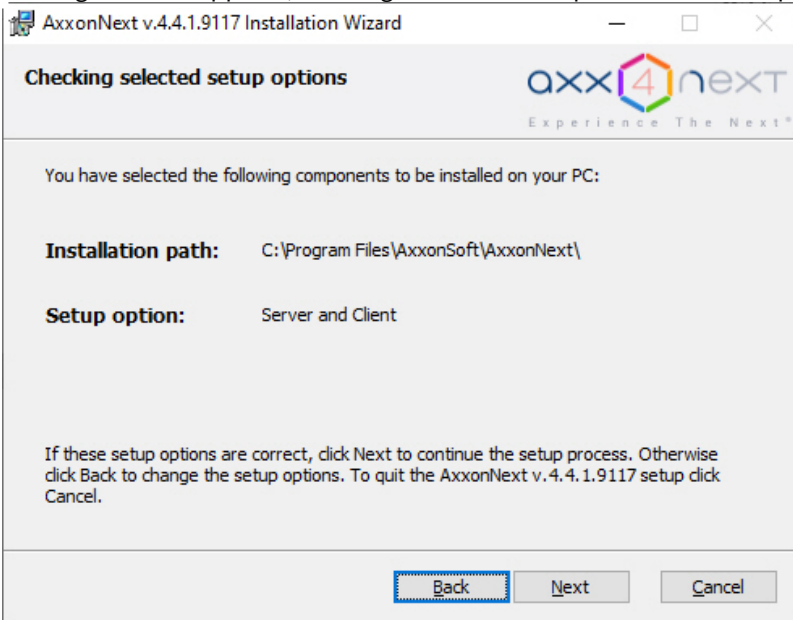

27. Verify your installation settings and click **Next** to begin installation of Axxon Next.

28. Installation of Axxon Next is then performed.

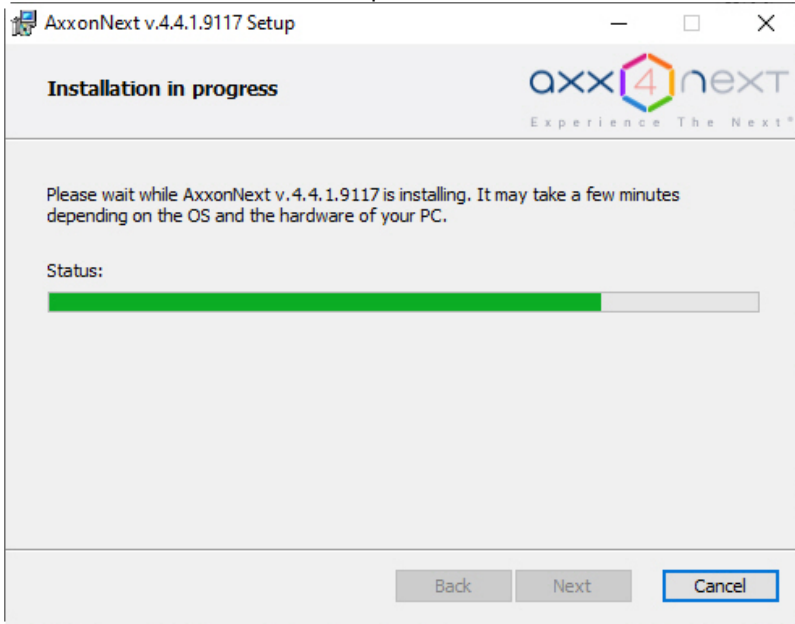

A message indicating the completion of Axxon Next installation will appear in a new dialog box.

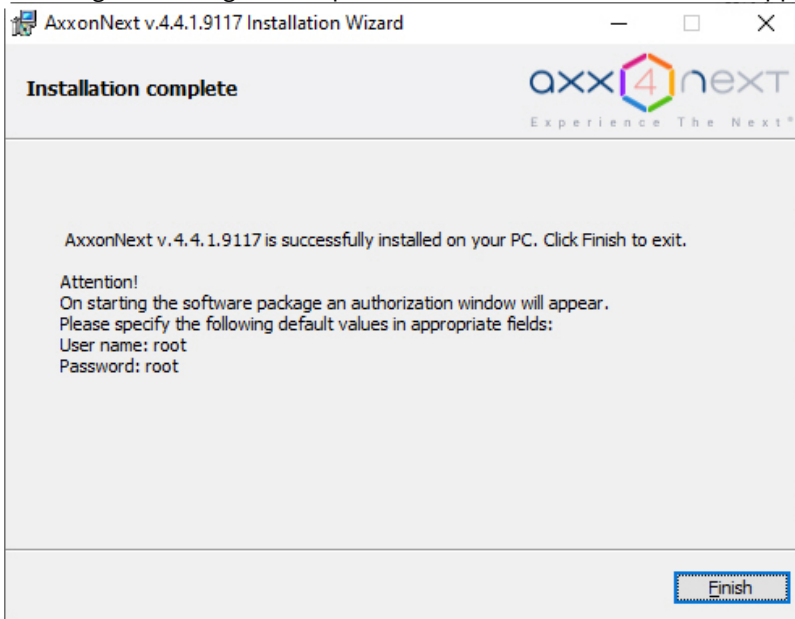

29. Click **Finish** to confirm completion of the installation.

Installation of Axxon Next is now complete.

4.2.2 Installing DetectorPack add-ons

By default, the Axxon Next VMS package only includes the basic DetectorPack, which contains the following set of detection tools:

1. Object Tracker (without Neural filter).
2. Water Level Detection.
3. Retail Analytics.
4. VMD.
5. Service Video Detection Tools.
6. Service Audio Detection Tools.

Additional DetectorPack packages (add-ons):

1. Addon Neuro Pack contains the following tools:
 - a. Neural Filter.
 - b. Neural Tracker.
 - c. Neural Counter.
 - d. Pose detection tools.
 - e. Smoke detection.
 - f. Fire detection.
2. Addon Face Recognition Pack contains Face Recognition and its subordinate detection tools.
3. Addon VT LPR contains Licence plate recognition (VT).
4. Addon RR LPR contains Licence plate recognition (RR).

To install these add-on packages, do as follows:

1. Download the required packages on the official [website](#).
2. Stop the Server (see [Shutting down a Server](#)).
3. Run the executable file and wait for the installation to complete.
4. Start the Server (see [Starting a Server](#)).

4.2.3 Repairing Installation

A repair installation is used to re-install all components of the Axxon Next software package.

To start a repair installation, launch the Axxon Next software installer from the installation CD without removing the previous version of the program.

Note

To ensure that Axxon Next is re-installed correctly, all related applications should be closed before starting the repair installation

To run a repair installation of the Axxon Next software, you must perform the following steps:

1. Insert the Axxon Next installation CD into the CD-ROM drive. A dialog box will display the disk contents.



2. Run the Setup.exe file.

3. Click **Next** on the setup wizard's welcome screen.

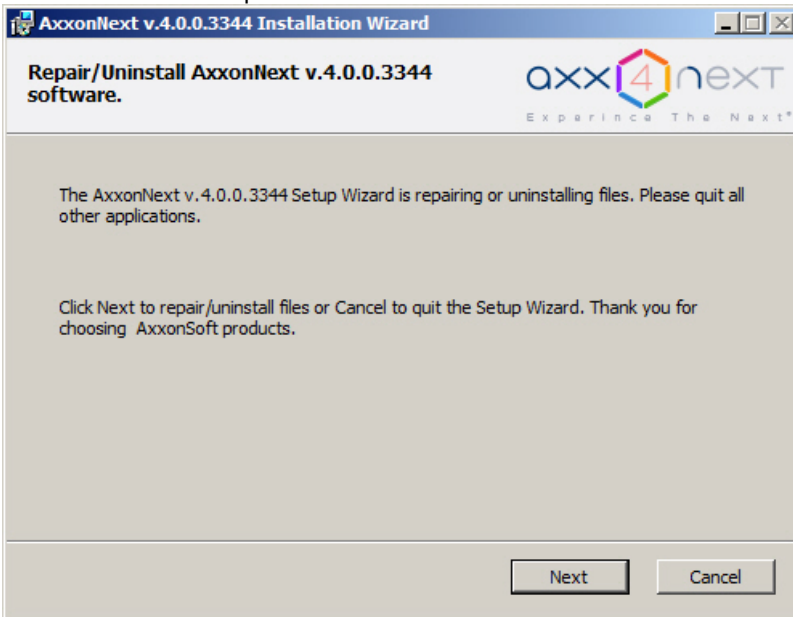

4. A dialog box will appear, allowing you to choose an operation.

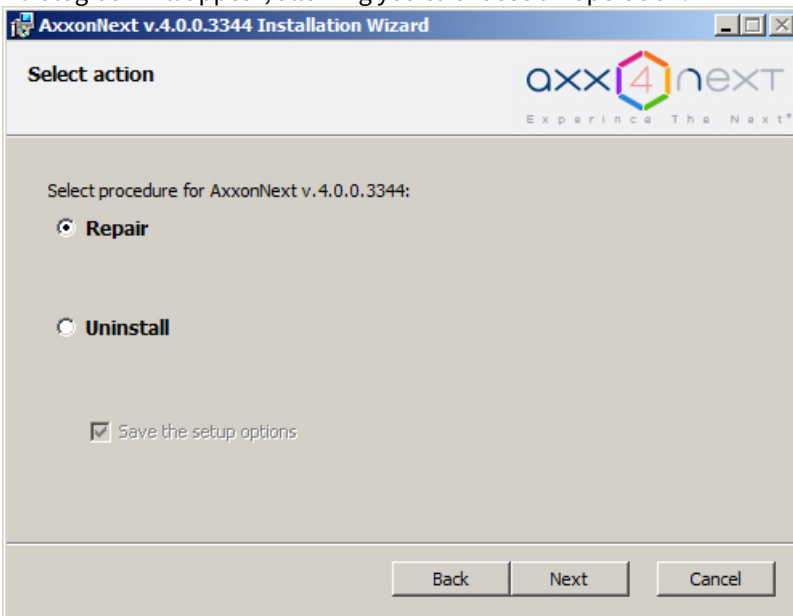

5. Select the **Repair** option and click **Next**.

A dialog box will appear, showing the Axxon Next repair process.

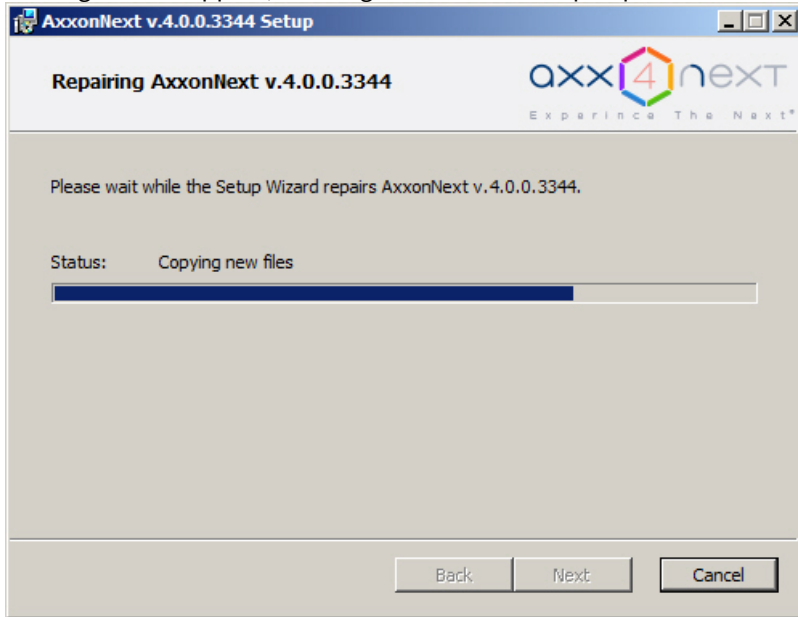

A dialog box will appear, indicating the completion of the repair process. Click **Finish**. Repair of Axxon Next is now complete.

4.2.4 Removal

The Axxon Next installation program can also remove the software. Use this option when you need to remove all components of Axxon Next from your computer.

Note

All related applications should be closed before beginning removal of the Axxon Next software

You can run the Axxon Next uninstaller via one of the following methods:

1. from the **Start** menu
2. using **Add or Remove Programs** in the Windows control panel
3. By starting the executable file named `setup.exe`, which is included with the installed version of the product.

When you do this, the setup wizard's welcome screen appears. To remove Axxon Next, you must observe the following procedure:

1. Click **Next** on the setup wizard's welcome screen.

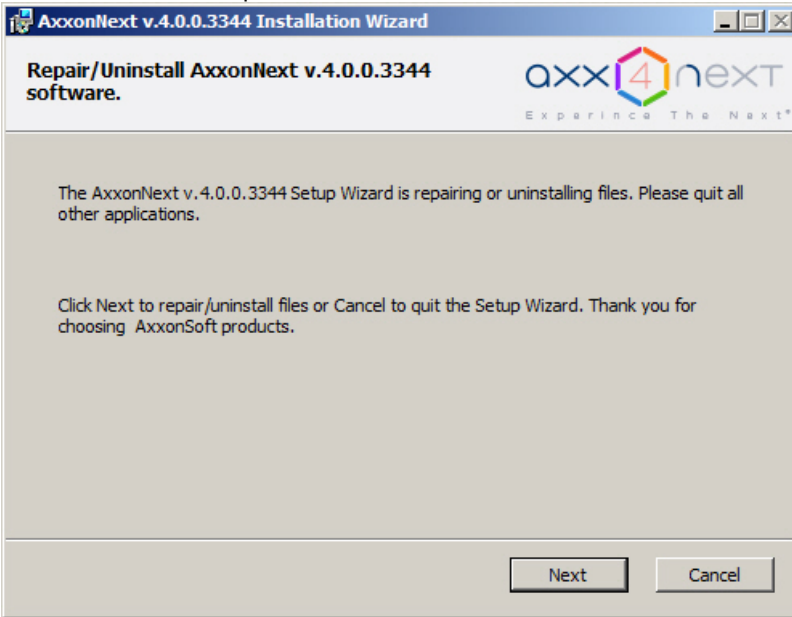

A dialog box will appear, allowing you to choose an operation.

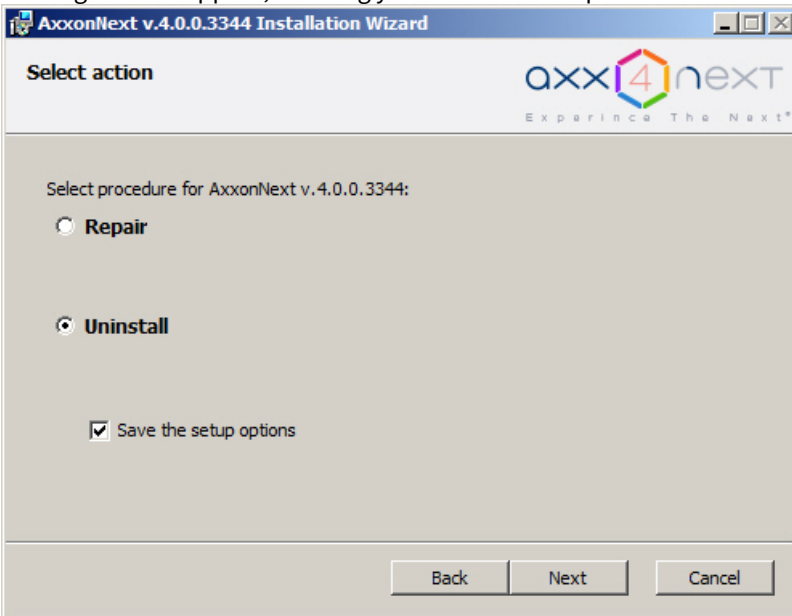

2. Select **Remove**.
3. To save your Axxon Next settings in a database, select the **Save configuration** check box. This option may be useful when updating the product.
4. Click **Next**.

A dialog box will appear showing the Axxon Next removal process.

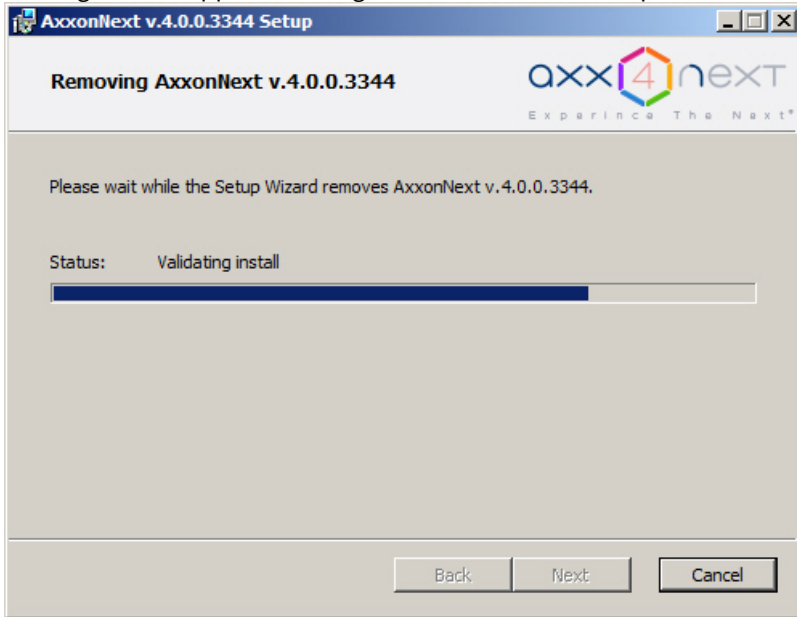

A dialog box will appear, indicating the completion of the removal process. Click **Finish**. Removal of Axxon Next is now complete.

Note

To completely remove Axxon Next, use the Windows Control Panel to remove the following software:

1. PostgreSQL.
2. AxxonSoft Situation detectors.ItvDetectorPack.
3. Axxon Driver Pack.

4.2.5 Update

If you have an earlier version installed, please perform a step-by-step upgrade: 3.6.4. → 4.1.0 → 4.3.2 → 4.4.6 → 4.5.0.

Attention!

You cannot directly upgrade to Axxon Next 4.5.0 from versions 3.6.466 and lower.

To upgrade from an older version, do the following:

1. Remove the old version.
2. Install the new version.
3. Reconfigure the system.

Attention!

For a failover system, we recommend you to update Servers through the supervisor service (see [Upgrading Servers within a cluster](#)).

Note

Before you start updating, do the following:

- back up your configuration (see [Backup and Restore Utility](#));
- stop the Server (see [Shutting down a Server](#)) or, in case of failover system, the NGP_Supervisor service. If you run multiple Servers in the Axxon domain, make sure to stop them all.

To upgrade to version 4.5.0, you must:

1. Run the new build installer.

Note

You do not need to remove the previous build.

2. Install the build using an existing configuration. The procedure is the same as for a new installation (see [Installation](#)).

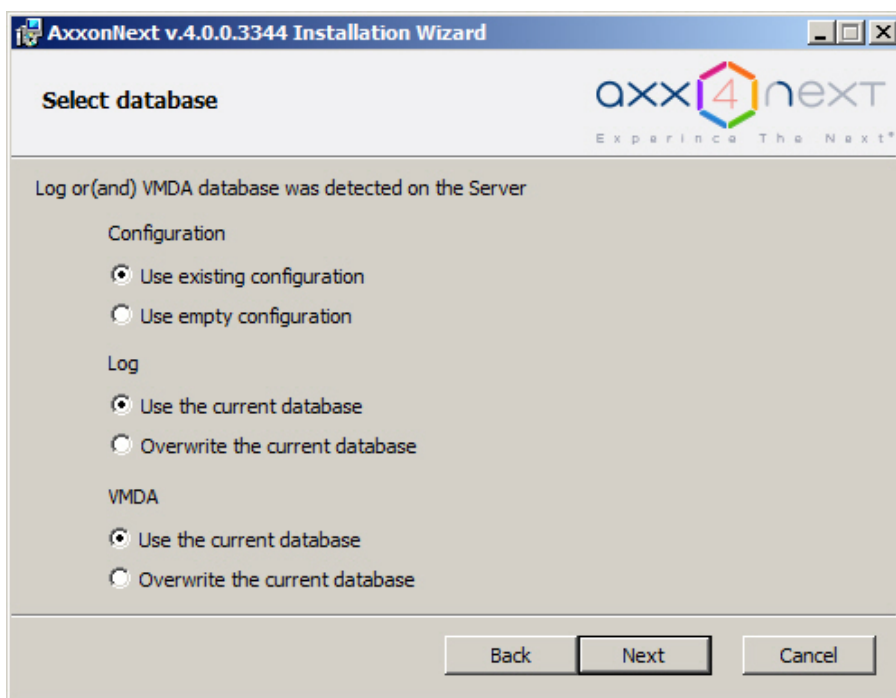
**Attention!**

When you update the software, keep DBs in the same folder. If you set a different location for DBs, the metadata and events from it will not be available.

4.2.6 Silent install (Quiet Mode)

You can run Axxon Next installation in quiet mode (unattended setup with no user intervention).

Note

During installation you may have to reboot the system. After rebooting the installation will continue automatically.

When Redist.exe process ends and not listed in Windows Task Manager, the installation is complete.

This mode of installation can be configured by adding command-line options to setup.exe. See the command-line options in the table.

Command-line option	Description
/? or /help	Open the Help window
/x or /uninstall	Remove Axxon Next and save the configuration
/x/removeall	Remove Axxon Next and delete the configuration
/r or /repair	Repair Axxon Next
/qn or /quiet	Silent install
/norestart	Disable automatic reboot of the system during installation
/debug	Log installation
/noOSCheck	Skip OS compatibility check
/postgresinstalldir="D:\Postgres"	PostgreSQL installation folder
/LANG="ru"	Select installation language ru - Russian en - English
/INSTALLTYPE="ServerClient"	Installation options: ServerClient - Server and Client (default) raftserver - Failover Server and Client Client
/ADD="[]"	Hers is the list of components to install or remove (if you remove/uninstall software) See the possible values in the table below.
/REMOVE="[]"	Hers is the list of components NOT to install or remove (if you remove/uninstall software) See the possible values in the table below.
/dpcmd="INSTALL_BOSCH_VIDEOSDK=\no\""	Bosch VideoSDK driver Installation (see notes) no - do not install yes - install
/CMD="[commands]"	Basic installation options and values. Commands are [option] = \ "[value] \" or [option] = [value] !. See available installation options in the table below.

Attention!

Occasionally, when installing the **Bosch VideoSDK** driver, the CLI window opens. To continue with installation, close this window.

/ADD and /REMOVE values:

x86	x64
Acrobat	Acrobat
BaseProduct	BaseProduct
IPDriverPack_x86	IPDriverPack_x86
Guardant_x86	Guardant_amd64
Postgres	Postgres
dotnetfx35_x86	dotnetfx35_x86
Redis2005_x86	Redis2005_x86
Redis2010_x86	Redis2010_x86
DetectorPack	DetectorPack

Installation options:

Installation options	Description
QUICKLAUNCH_SHORTCUT='1'	Create shortcut: 1 - Yes (default) 0- No
DESKTOP_SHORTCUT='1'	Copy shortcut to desktop: 1 - Yes (default) 0- No
INSTALLDIR='[%ProgramFiles%\AxxonSoft\AxxonSmart]'	Axxon Next installation folder
NGP_IFACE_WHITELIST="0.0.0.0/0"	Network interfaces The default value is "0.0.0.0/0" (all available network interfaces) Format of network interfaces: "IP-address1 / number of unit bits in the mask, IP-address2 /number of unit bits in the mask"
NGP_ALT_ADDR="0.0.0.0"	Setting the outside local address for a Server behind the NAT . Format of network interfaces: "IP Address1 or DNS-name1, IP address2 or DNS Name2"
PORT_RANGE_START="20111"	The initial value of the port range for Server. 20111 - default.
PORT_RANGE_COUNT="100"	Number of ports in use. The minimum number is 20. 100 - default.
<u>Options for Server and Client installation</u>	
PATH_TO_DATABASE='[INSTALLDIR]Metadata'	Path to object tracking DB.

Installation options	Description
FBUSER_TYPE='DEFAULT'	User account for file explorer: DEFAULT - Create a new account; the default name selected will be AxxonFileBrowser. SYSTEM - Select an account from the Local System. SPECIFY - Create a new account; choose the user name and password.
FBUSER_NAME='[AxxonFileBrowser]'	Setting a user name and password for an account in file explorer.
FBUSER_PSW='[Axxon2.0.0]'	When you choose SPECIFY of the FBUSER_TYPE parameter
CONFIG_PATH='[CommonAppDataDirectory]'	Path to configurations files and folders
DOMAIN_NAME_TYPE = '[NewDomain]'	Select Axxon-domain: NewDomain - create new Axxon Domain (default); WithoutDomain - do NOT add Server to Axxon Domain TheSameDomain - use existing Axxon-domain
WHATDBUSE = '[EXIST]'	EXIST - Use existing log DB (default) NEWDB - Create new DB
WHATVMDADBUSE = '[EXIST]'	EXIST - Use existing object tracking DB (default) NEWDB - Create new DB

The command for silent installation of Axxon Next may look like:

```
setup.exe /quiet /norestart /debug /INSTALLTYPE="ServerClient" /REMOVE="Guardant_x86" /
CMD="CREATE_QUICKLAUNCH_SHORTCUT="\0\" PORT_RANGE_COUNT="\50\" DOMAIN_NAME_TYPE="\WithoutDomain\""
```

This will launch installation with the following options:

1. quiet mode (/quiet);
2. no reboot (/norestart);
3. log installation to file (/ debug);
4. **Server and Client** (/ INSTALLTYPE = "ServerClient");
5. No *Guardant drivers* (/ REMOVE = "Guardant_x86");
6. And with the following properties (/ CMD =):
 - a. no shortcut (= "CREATE_QUICKLAUNCH_SHORTCUT="\0\"");
 - b. 50 ports for Server (PORT_RANGE_COUNT="50");
 - c. Server NOT added to Axxon-domain (DOMAIN_NAME_TYPE = '[WithoutDomain]').

4.2.7 Updating Drivers Pack

To install the latest version of Drivers Pack, do as follows:

1. Run the IPDriverPack.msi file.
2. After the installation is complete, restart the Server (see [Shutting down a Server, Starting a Server](#)).

Note

Please note that, if Drivers Pack 3.2.0 or an earlier version is installed, you should first uninstall the earlier version.

4.2.8 Automatic update of a remote Client

If a Server software version is higher than the Client's, you will be offered to update your Client software automatically.

Attention!

You should launch the Client as administrator to make it automatically updatable.

Note

If the Client PC has a Server installed, no update will be possible.

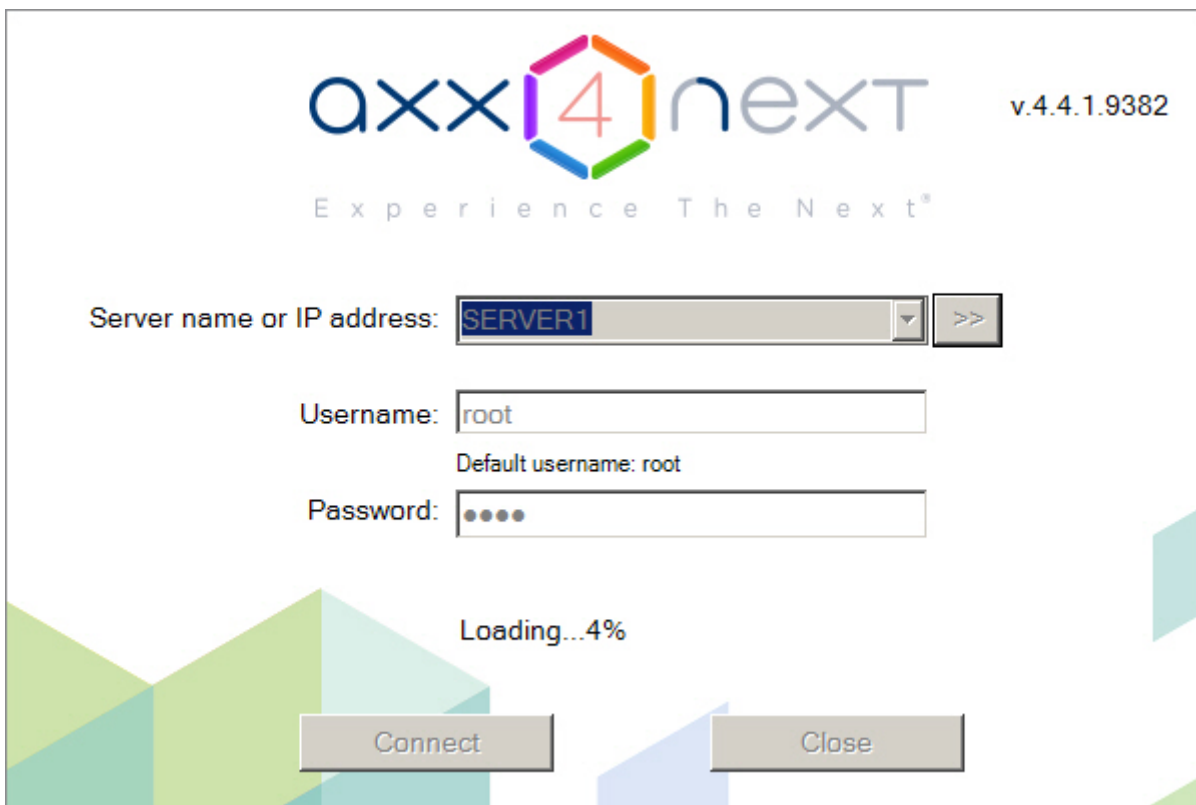
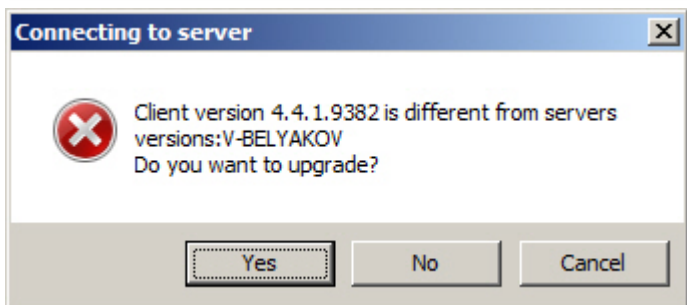

Next, the Client will be updated automatically along with Detector Pack and Driver Pack driver modules (if required).

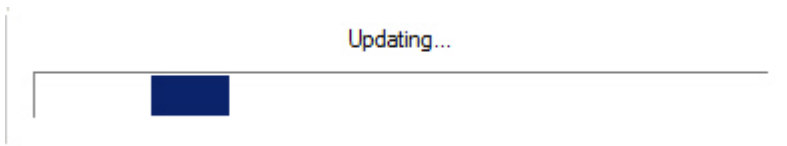

Note

The update may lead to a reboot.

5 Licensing of the software product

5.1 Axxon Next license types

There are 5 types of *Axxon Next* license: **Demo**, **Free**, **Start**, **Professional**, and **Universe**. Upon installation, the software will be launched in demo mode.

You should activate Axxon Next VMS to utilize the full feature set of the security software package. You can activate the software by distributing an activation key on the system.

As for validity of the license, there are two types:

- Unlimited
- 1 year subscription

Data on all the types of Axxon Next licenses is presented below.

Functionality	Type of license	Axxon Next Demo (8:00-18:00)*	Axxon Next Free	Axxon Next
Maximum number of Servers in Axxon domain		Unlimited	1	Unlimited
Maximum number of channels in Axxon domain		Unlimited	4	64
Support for SD cards (edge storage)		Yes	No	Yes
Macros		Yes	No	Yes
Situation analysis detection tools (excluding line crossing)		Yes	No**	Yes
Line crossing		No	No	Yes
Events from external systems (POS terminals, ACFA)		Yes	No	Optional
Scene synopsis (TimeCompressor)		No	No	No
Cross-System Client		No	No	No
Advanced archive search: <ul style="list-style-type: none"> • MomentQuest • Face search • LPR search*** 		Yes	No	No****
Tag&Track Pro		Yes	No	No
Retail Analytics: <ul style="list-style-type: none"> • Visitors counter • Queue detection • Heat map • AxxonNet reports 		Yes	No	No
Face recognition evasion detection		Yes	No	No

Neural Tracker Neural Counter	Yes	No	No
Smoke and fire detection	Yes	No	No
Pose detection	Yes	No	No
Personal protective equipment detection	Yes	No	No
Water level detection	Yes	No	No
IntelliVision Automatic Number Plate Recognition	No	No	No
Online facial recognition	Yes	No	No
FaceCube external face recognition module	No	No	No
Online Vehicle License Plate recognition*****	Yes	No	No
Searching for LPR numbers on video from multiple cameras	Yes	No	No
Data replication	No	No	No
Failover	No	No	No
Video walls management	Yes	No	No
LDAP authentication supported	Yes	No	No
Offline analytics	No	No	No
System features available for all licenses			
Hardware Control panels Security keyboards Joysticks I/O modules	Unlimited	Unlimited	Unlimited
AxxonNet cloud service	Yes	Yes	Yes

<p>Server</p> <ul style="list-style-type: none"> Support for ONVIF (profiles G, S, T), RTSP, GB/T28181 H.265 support Metadata from IP devices Configuration backup and restore Mass configuration of cameras Multicasting Hotkeys 	Yes	Yes	Yes
<p>Recorded Video / Investigation</p> <ul style="list-style-type: none"> Local and network archives Events search TimeSlice Operator comments 	Yes	Yes	Yes
<p>Live Monitoring</p> <ul style="list-style-type: none"> Basic audio and video analytics Embedded detection tools (except for Axis on-board tracker *****) Interactive 3D map GreenStream Tag& Track Lite OnScreen PTZ mode Support for fisheye cameras and ImmerVision lenses Export of snapshots and video episodes to multiple formats Information boards 	Yes	Yes	Yes
<p>Remote clients</p> <ul style="list-style-type: none"> Web client iOS app (including Apple TV) Android app 	Yes	Yes	Yes

Information about the type of license you are using is displayed in the server properties in the **Product Type** field.

* The system will operate in demo mode from 8:00 AM to 6:00 PM.

** Axxon Next Free license allows you to further use metadata from core VMD with any Scene Analytics detection tool except line crossing and abandoned objects tools.

*** Please contact our sales team to confirm if LPR country is supported and find out more about licensing policy.

**** Axxon Next Start license allows you to use metadata from a basic VMD with the MomentQuest forensic search.

***** To use VT and IV automatic number plate recognition tools, you have to re-activate the updated license of the ANPR.

***** the module has to be purchased separately.

Note

You (**admins** users) get a reminder to renew license 30 days before it expires.

5.2 Licensing methods

There are two licensing methods for Axxon Next:

1. License file only

The license file contains data on basic hardware configuration (motherboard, processor, hard disk, video adapter, RAM, and network card) of all Servers. If you change any 2 of the basic hardware components, your license will be invalid. For example, this is the case when you change both CPU and motherboard. However, changing a graphics card or upgrading RAM will not affect the license.

This is why when working with Axxon Next you should bear in mind the following:

- a. The activation request should be sent from the computer that will host the Axxon Next Server.
- b. You can upgrade your license only if you retain the initial basic hardware configuration of all the Servers.
- c. It is not possible to transfer a license from one computer to another.

2. License file + Guardant dongle.

this method allows replacing server hardware and transferring the license to another computer. To activate Axxon Next via this method, contact AxxonSoft to receive a license file and Guardant dongle.

If you already have a Guardant dongle, you can perform activation yourself. To do so, connect the Guardant dongle to the computer that you wish to activate and perform the standard activation steps.

Attention!

You may use a Guardant Sign key with Linux.

Note

If you install virtualization products such as VirtualBox, VmWare etc. , this may affect the license. Should you encounter this problem, you are advised to uninstall all virtualization products or apply for a new license file

5.3 Product Activation Utility

License activation for the Axxon Next software package is carried out through the product activation utility.

You can launch the product activation utility from the Windows **Start** menu: **Start -> All Programs -> Axxon Next -> Utilities -> Program Activation.**

Note

The product activation utility program file LicenseTool.exe is located in the folder <Directory where Axxon Next is installed>\AxxonSoft\AxxonSmart\bin\

Then you must select the name of one of the Axxon Domain servers to which the license file will be applied (the file is applied to all Axxon Domain servers launched at the moment of activation) and connect to the system, under an administrator's user name and password, to continue the activation process.

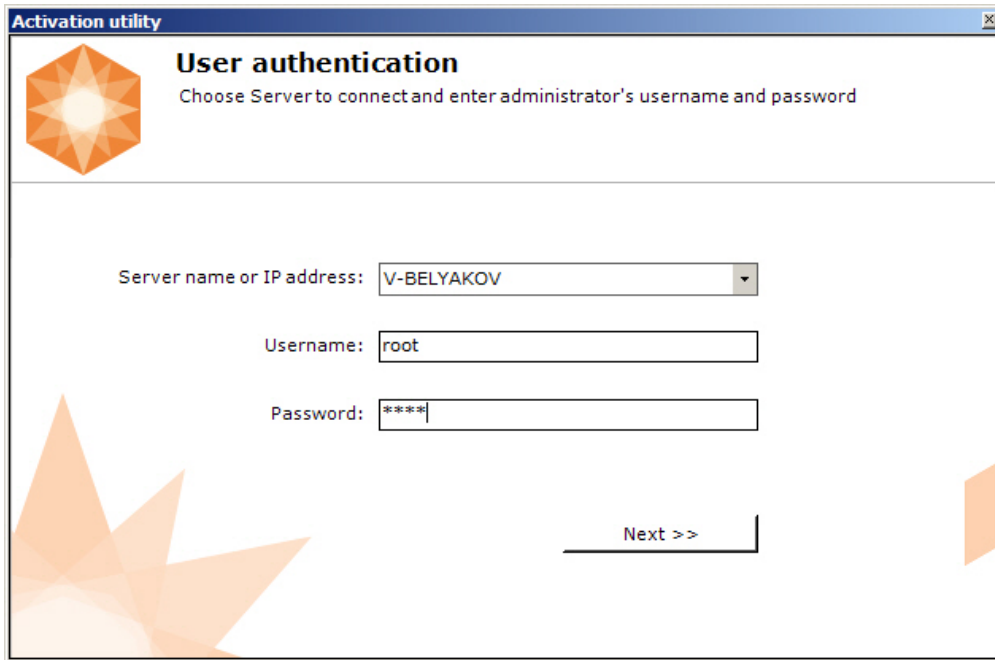

Activation utility

User authentication
Choose Server to connect and enter administrator's username and password

Server name or IP address: V-BELYAKOV

Username: root

Password: ****

Next >>

When the utility has loaded, its main will be displayed.

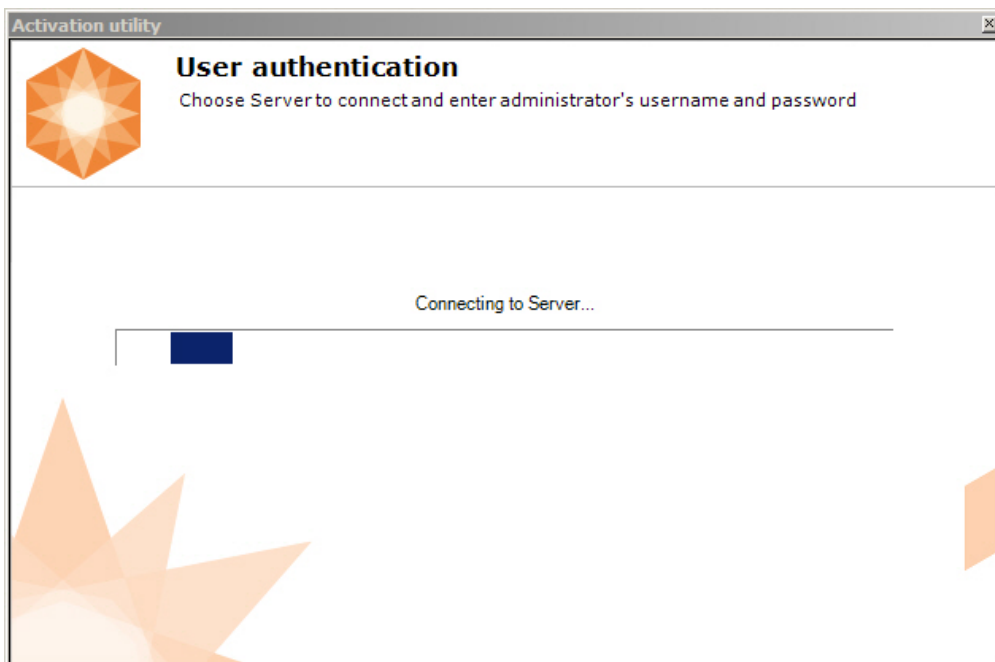

Activation utility

User authentication
Choose Server to connect and enter administrator's username and password

Connecting to Server...

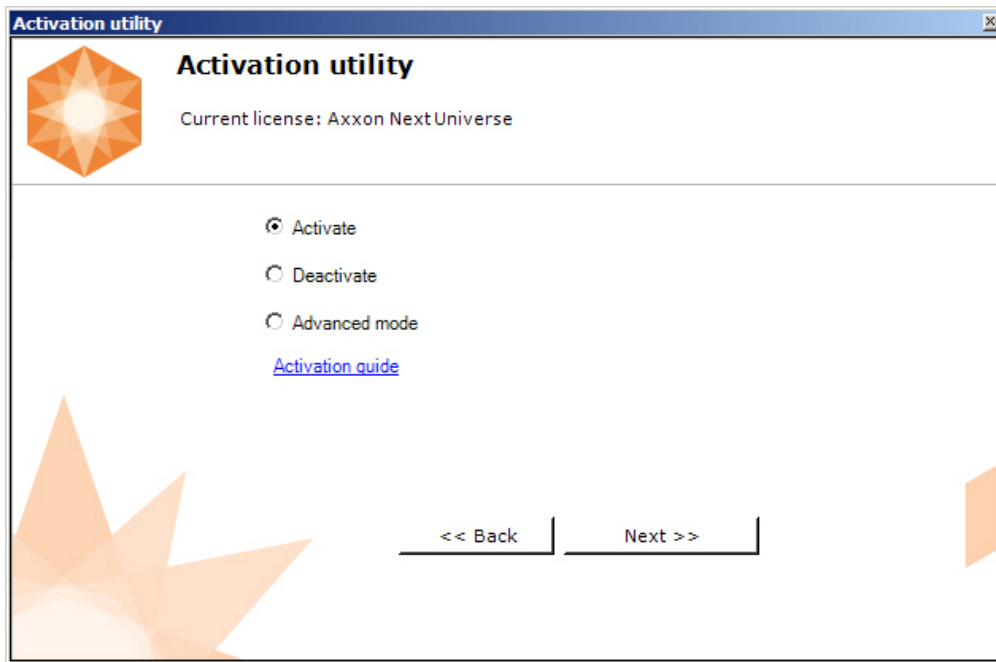

5.4 License Activation

To activate Axxon Next, please refer to the document titled [Activation Guide](#), which presents step-by-step instructions on activating, updating and upgrading Axxon Next .

It is also recommended that you use the prompts displayed in the product activation utility's dialog boxes .

6 Launching and Closing the Axxon Next Software Package

6.1 Startup

6.1.1 Starting a Server

The *Axxon Next* Server is started automatically when the operating system starts.

If a Server's operation was stopped, you must complete one of the following actions to restart the Server:

1. Restart the system
2. Select **Start -> All Programs -> Axxon Next -> Start Server**

Note

Run the command with administrator permissions.

3. Start NGP Host Service

6.1.2 Starting an Axxon Next Client

The Axxon Next client can be started manually using the **Start** menu, which is intended for launching user programs in Windows.

Note

To launch the Client from command line, you have to specify the following parameters: LOGIN, PASSWORD and SERVER.

For example: C:\Program Files\AxxonSoft\AxxonNext\bin>AxxonNext.exe -LOGIN=root -PASSWORD=root -SERVER=127.0.0.1

To connect to multiple Servers, specify their addresses separated by commas.

For example: C:\Program Files\AxxonSoft\AxxonNext\bin>AxxonNext.exe -LOGIN=root -PASSWORD=root -SERVER=10.0.11.30, 10.0.11.34

To start working with the software, perform the following steps:

1. Select **Start -> All Programs -> Axxon Next -> Axxon Next**

Note

The Axxon Next software package program file AxxonNext.exe is located in the folder <Axxon Next installation folder>\Axxon Next\bin\

Note

To start the client in Safe mode with OpenGL software emulation, select: **Start-> Programs-> Axxon Next-AxxonNext (Safe mode)**.

The Axxon Next client will then launch and an authorization window will appear

axxon4next v.4.1.0.5920
Experience The Next®

1 Server name or IP address: S-ROZIN 20111 >>

Username: root

2 Password: ●●●●

Connect Close

2. Select a Server to connect to, and specify a port number (1).

Connecting the Client to the Server behind NAT

Note

If the software is accessed by a remote user, the NetBIOS name or IP address of the computer with which the connection is established should be indicated in the **Server name or IP address** field.

Note

The order of the servers in the list is as follows:

- a. Preferred Servers (see [Selecting Preferred Servers](#)).
- b. The latest server that was connected to.
- c. Other Servers are in alphabetical order.

3. Enter the user name and password (2) and click **Connect**.

Note

The first login to the system is done with the user root, which has administrator permissions . Enter root in the **User Name** and **Password** fields. The administrator then needs to configure the system for multi-user access described in detail in the section titled [Configuring user permissions](#))

Attention!

You need to match software versions between the Server and the Client. The Drivers Pack's version must be the same as well.

If the Server's version is higher than the Client's, you will be offered to update your Client software (see [Automatic update of a remote Client](#)).

It is strongly recommended to avoid any connections if the product versions do not match.

Connecting LDAP users

4. If the user requires the access confirmation by the system administrator, enter corresponding credentials and click **Connect**.

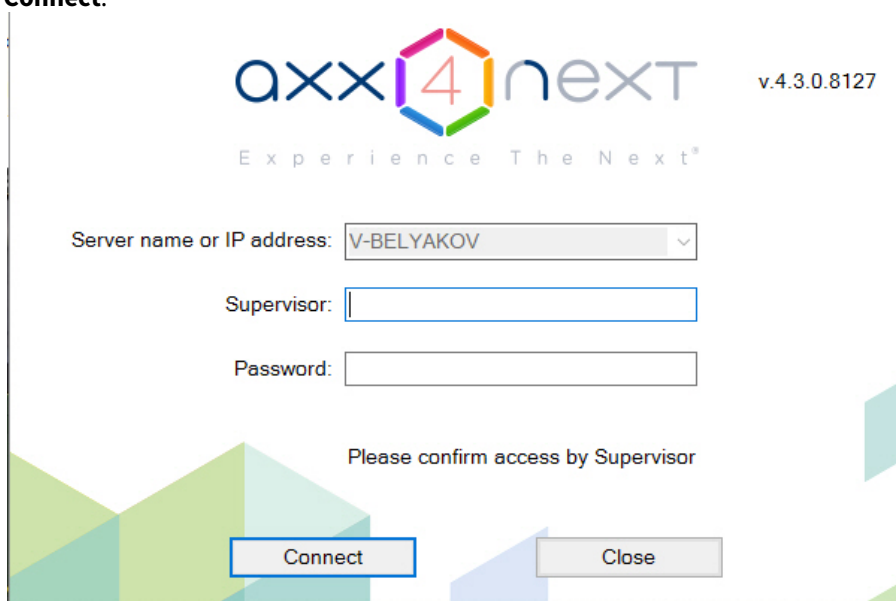

axxon4next v.4.3.0.8127
Experience The Next®

Server name or IP address: V-BELYAKOV

Supervisor:

Password:

Please confirm access by Supervisor

Connect Close

Attention!

When you first start the client, the archive settings tab opens (see [Configuring Archives](#)).

After the archive is created, camera addition starts automatically (see [Adding and removing IP devices](#)). IP Device Discovery Wizard launches.

If authorization is successful, a video surveillance monitor will be displayed on the screen.

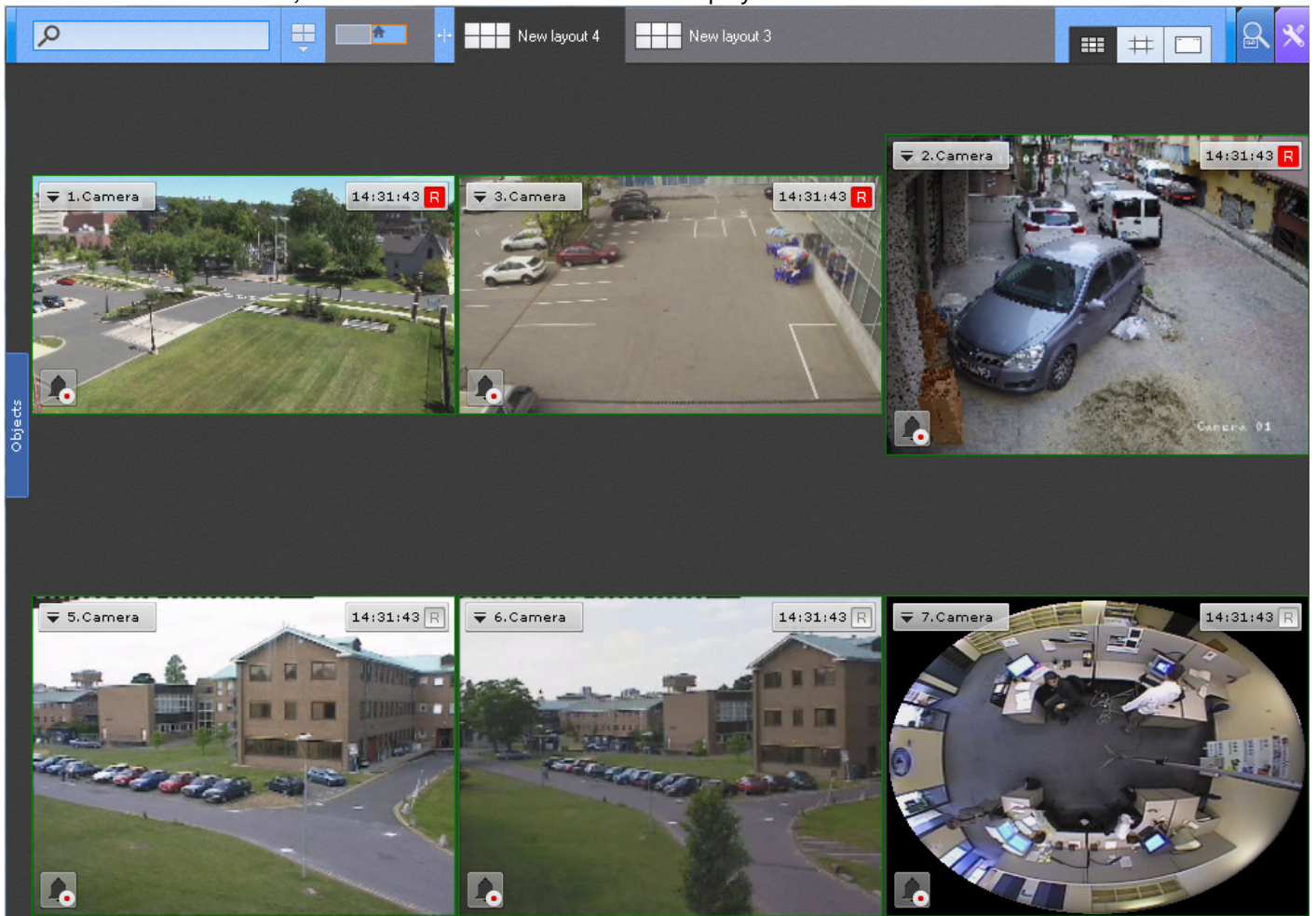

Note

If Axxon Next is launched in demo mode, then after you enter the authorization parameters, a message to this effect will appear (see the section [Axxon Next in demo mode](#))

If the Server to which Axxon Next is connecting does not belong to any Axxon Domain, after the **Connect** button in the authorization window is clicked, a message is displayed.

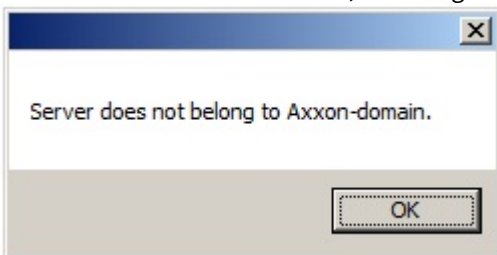

To connect to the Server, you must either create a new Axxon Domain based on the server or add the Server to an existing Axxon Domain.

If you choose the first option, click **OK** in the message and follow the instructions given in the section [Creating a new domain](#). For the second option, click the  button and follow the instructions given in the section [Adding a Server to an existing Axxon Domain](#).

6.1.3 Running multiple Axxon Next Clients

You can run multiple Axxon Next Clients simultaneously on a single computer in order to connect to different Servers.

In this case, you must start Clients with the additional parameter **-monitor=N**, where N is the number of the monitor on which the Client is to be started.

Attention!

The maximum number of running Clients is limited to the number of connected monitors that support the minimum required resolution (see [Limitations of the Axxon Next Software Package](#)).

You can run only one Client on a single monitor.

To run multiple Clients:

1. On your desktop, create a number of Client shortcuts equal to the number of connected monitors.
2. In the properties of each shortcut, in the **Target** line, add the additional parameter **-monitor=N**.

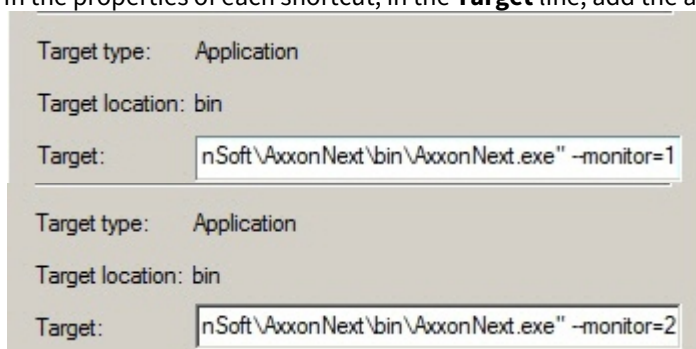

3. Start the Clients by using the shortcuts.

Note

If a Client is started in window mode (see [Configuring the Client screen mode \(full screen or window\)](#)) and moved to another monitor, the situation changes: Clients will be started on the specified monitors even if a Client is already running on one or more of them.

6.1.4 Axxon Next in demo mode

If activation has not been completed, *Axxon Next Free Versions* works in demo mode.

The system will operate in demo mode from 8:00 AM to 6:00 PM. There are limitations to functionality (see [Axxon Next license types](#)).

The different types of demo modes are presented in Table.

Type of demo mode	Conditions	Axxon Next operation
Active	Axxon Next can be started between the hours of 8:00 AM and 6:00 PM	Using <i>Axxon Next</i> in demo mode
Inactive	Axxon Next started outside the hours of 8:00 AM and 6:00 PM	The Axxon Next server is not available, only the system configuration can be viewed

If a Client is connected to an Axxon Domain in which there is at least one Server running in demo mode, an appropriate message is displayed, along with a list of Servers in the Axxon Domain and their types of licenses.

Note

The notification is displayed after successful authorization

If an Axxon Domain includes at least one Server running in active demo mode, you will be given the option to continue working (2) or start the activation utility (1).

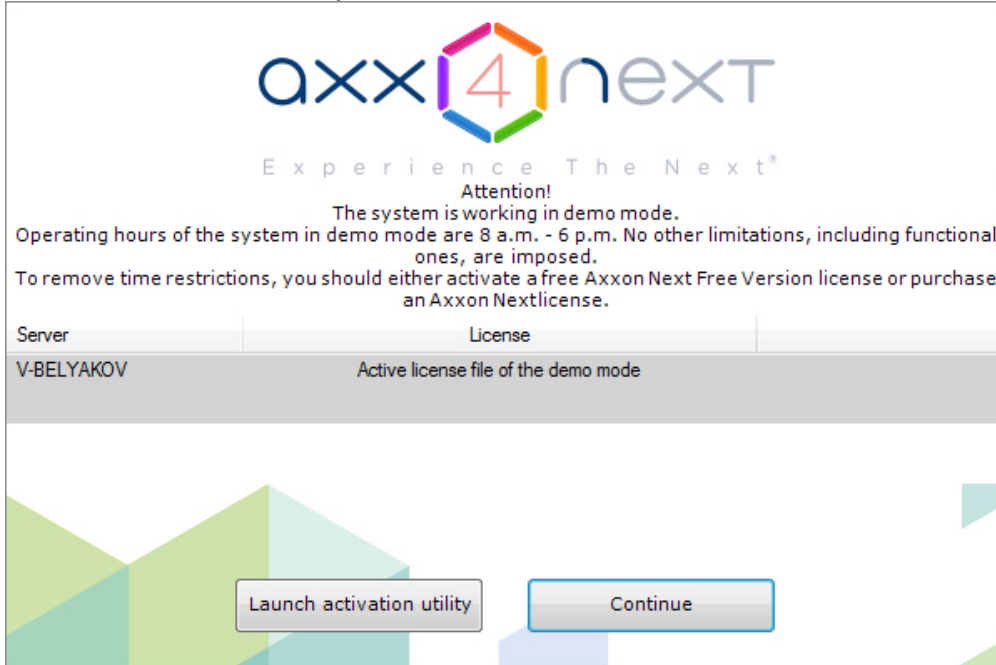

6.1.5 Automatic Start of the Client

You can use [Windows Task Scheduler](#) to configure the *Axxon Next* client to start automatically at the system start-up.

It is recommended that you specify a Server start-up delay.

Note

You can also configure automatic authorization for the Client upon start-up (see [Configuring Cross-System Client and autologon](#)).

6.2 Shutdown

6.2.1 Shutting down an Axxon Next Client

Before closing Axxon Next, you need to exit the user interfaces. To do this, perform one of the following:

1. Click the  button located in the top-right corner of the Axxon Next dialog box.

Note

If the client is opened in full-screen mode (enabled by default), the  is not displayed. In this case you can exit the user interfaces using actions 2 and 3

2. In the **Settings** tab, click the  button.
3. In the Windows taskbar notification area, in the context menu of the Axxon Next icon, select **Close window**.

When you perform one of these actions, the authorization window will appear. To close Axxon Next (completely exit the client), click the **Close** button.

The screenshot shows the Axxon Next authorization interface. At the top, the logo 'axxon4next' is displayed with the version 'v.4.1.0.5920' and the slogan 'Experience The Next'. Below the logo, there are three input fields: 'Server name or IP address' (a dropdown menu currently showing 'V-BELYAKOV'), 'Username' (containing 'root'), and 'Password' (empty). At the bottom of the window, there are two buttons: 'Connect' and 'Close'.

6.2.2 Shutting down a Server

To shut down an *Axxon Next* Server, complete one of the following actions:

1. Select **Start -> All Programs -> Axxon Next -> Shut down Server**

Note

Run the command with administrator permissions.

2. Stop the NGP Host Service.

6.3 Automatic Server restart

If you change the following network settings in the operating system, the *Axxon Next* Server is automatically rebooted:

- IP address;
- creating a new network connection;

Attention!

While the Server restarts, the connection to cameras is temporarily lost and recording stops

6.4 Switching Users Quickly

You can switch Axxon Next users quickly without fully exiting the client.

To do this, follow the steps below:

1. Exit the Axxon Next user interface (see the section [Shutdown](#)).

The screenshot shows the Axxon Next login interface. At the top, the logo 'axxon4next' is displayed with the version 'v.4.1.0.5920' and the tagline 'Experience The Next'. Below the logo is a dropdown menu labeled 'Server name or IP address' with the value 'V-BELYAKOV'. Underneath is a login form with two fields: 'Username' containing 'root' and 'Password' which is empty. At the bottom of the form are two buttons: 'Connect' and 'Close'.

2. When the authorization window appears, enter the user name under which you need to log in and the corresponding password and click **Connect**.

Switching users is now complete.

6.5 Cross-System Client

Cross-System Client empowers users to connect to multiple servers on various domains and in different systems from a single client workstation. All settings and cameras associated with these servers are consolidated in a single convenient view. That way you can access multiple independent surveillance systems simultaneously, even if the customer cannot or does not want to combine these systems.

This may happen for various reasons, such as:

1. your facilities are geographically dispersed, or
2. you want to mass configure multiple cameras from different systems.

A typical scenario may involve police plugging Cross-System Client in security systems at different retail chains / stores.

Cross-System Client automatically connects to specified Axxon domains when you start it (see [Configuring Cross-System Client and autologon](#)). The client first connects to the primary Axxon domain; connection to the other Axxon domains is established in the background after the client starts.

axxonnext v.4.1.0.5920
Experience The Next®

Server name or IP address: V-BELYAKOV:49999, S-ROZIN:49

Username: root

Password: ●●●●

Connecting to V-BELYAKOV...

Connect Close

Note

You can also configure the Client connections to Axxon domains in the sign-up in the authorization dialog box. To do this, enter comma-separated values for Servers as follows: <Server 1 Name or IP address>:<Connection port>, <Server 2 Name or IP address>:<Connection port>. Server 1 is the primary connection

6.6 Connecting LDAP users

LDAP users are connected to the system in two steps:

1. The user logs in on the LDAP server.
2. The user then authenticates on the Axxon Next server.

Attention!

Each Client to which LDAP users are connecting must have access to the LDAP catalog.

Note

When an LDAP user connects, the user's login and password in the LDAP as configured in the Server settings are used (see [Creating LDAP connections](#)). The login and password in the LDAP directory are not used when connecting to the Server.

6.7 Connecting to Another Server Quickly

You can connect to another server without fully exiting the client.

To do this, follow the steps below:

1. Exit the Axxon Next user interface (see the section [Shutdown](#)).
2. When the authorization window appears, select the server to which you need to connect the client from the **Computer** list.
3. Enter the user name under which you need to log in and the corresponding password and click **Connect**.

Connection to another server is now complete.

7 Configuration of the Axxon Next Software Package

7.1 General information on system configuration

7.1.1 System configuration: stages

Most system configuration is performed via the **Settings** expanding menu, which contains six tabs for configuring certain parts of the system.

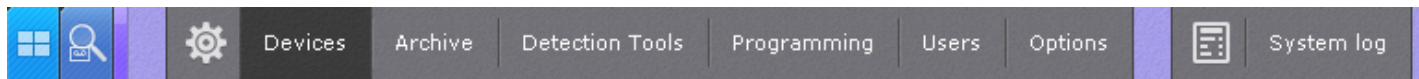

The main stages of system configuration are:

1. Configuring an Axxon domain.
2. Connecting and configuring hardware.
3. Configuring archives.
4. Configuring layouts and the interactive map.
5. Configuring users and roles.

Attention!

Please avoid changing system settings from different Clients simultaneously.

7.1.2 Applying and resetting settings

For a change in the system settings to take effect, you must click the **Apply** button.

After you click the button, a progress bar indicates that the settings are being applied. You can resume working with the system after the process completes.

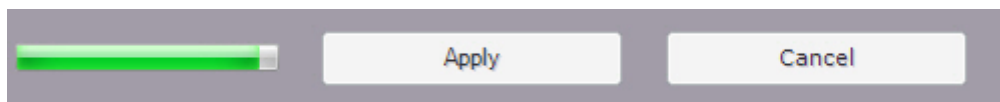

If you want to discard changes and have not clicked the **Apply** button, click **Cancel**.

If an attempt is made to close the Client but not all changes have been saved yet, a dialog box asks whether to confirm closing or to cancel closing and save changes.

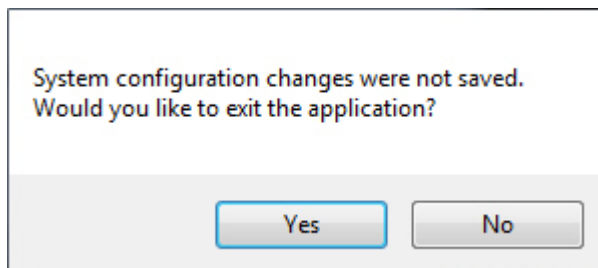

When setting up hardware, you can reset parameters to default values, or read configuration from the device at any time.

To reset parameters to default values, do the following:

1. Select the required device in the objects tree.

2. Click , then **Reset parameters to default values**.

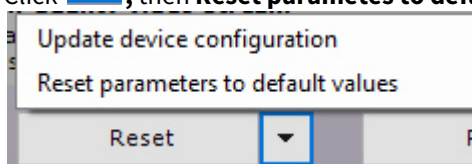

If a device's configuration differs from settings specified within the system, you can download the configuration from the device. To do it, follow the steps below:

1. Select the required device in the objects tree.
2. Click , then **Update device configuration**.

7.1.3 Display of parameters in interface

Most system parameters and hardware parameters are displayed in the Axxon Next interface.

The description of a parameter is usually displayed in a special area when the relevant parameter is selected.

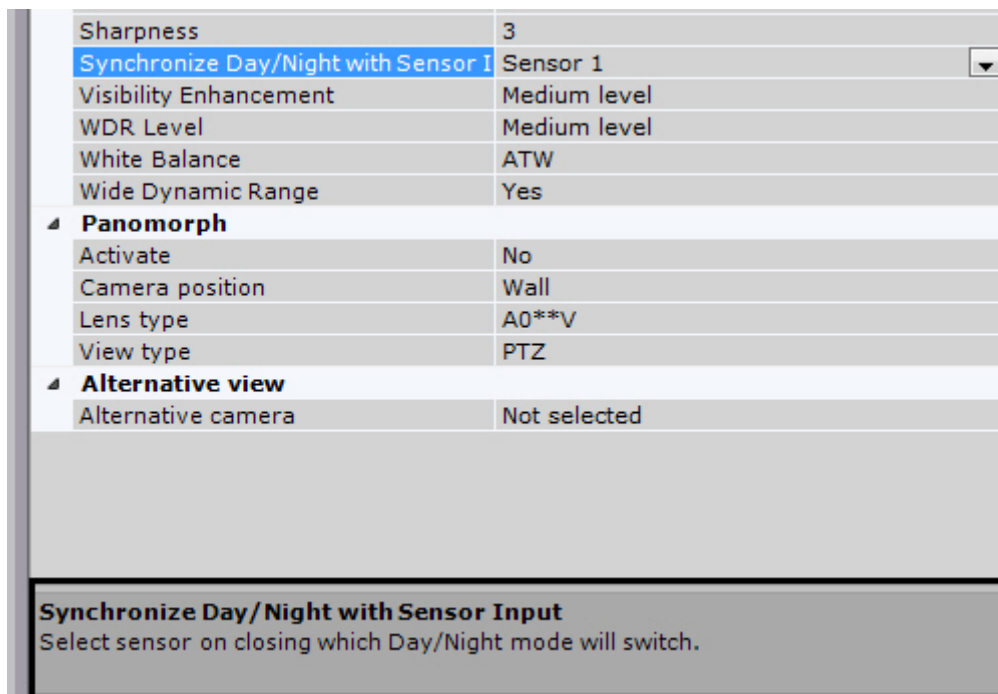

If the description of a parameter is truncated, you can stretch this area above the upper border.

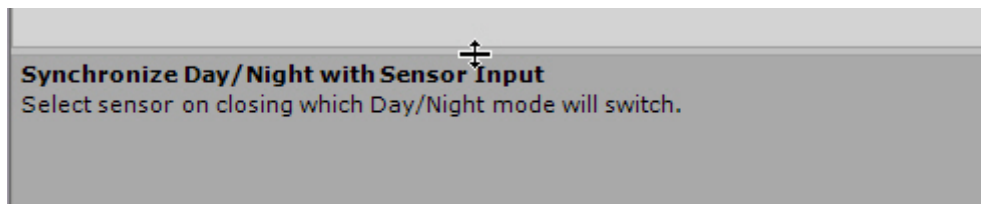

7.1.4 System objects

Axxon Next VMS has the following types of system objects:

1. Axxon domain objects (see [Configuring Axxon domains](#)).
2. Hardware objects: Server, IP Server, Camera, Microphone, PTZ, Input, Output, Embedded Storage (see [Configuring System Objects for Devices](#)).

3. **Event Source** objects are used to integrate *Axxon Next* with external systems (see [Receiving Events from External Systems](#)).
4. **SMS and e-mail** objects used in macros and automatic rules for SMS and e-mail notifications (see [The SMS Object](#), [The E-mail Object](#)).
5. **Export Agent** objects used in macros and automatic rules for exporting video recordings and snapshots (see [Configuring export](#)).
6. Archive objects (see [Configuring Archives](#)).
7. Detection tool objects (see [Configuring detection tools](#)).
8. Role and user objects (see [Configuring user permissions](#)).
9. Macro objects (see [Configuring Macros](#)).

Some objects are created automatically, while others are created manually or are pre-created in the system.

7.1.5 Object search

Axxon Next allows you to search for objects in the objects tree using only part of their name or the IP address. An object search can be performed on all tabs under **Devices**.

To search for objects, complete the following steps:

1. Select the tab containing the object tree that you need to search

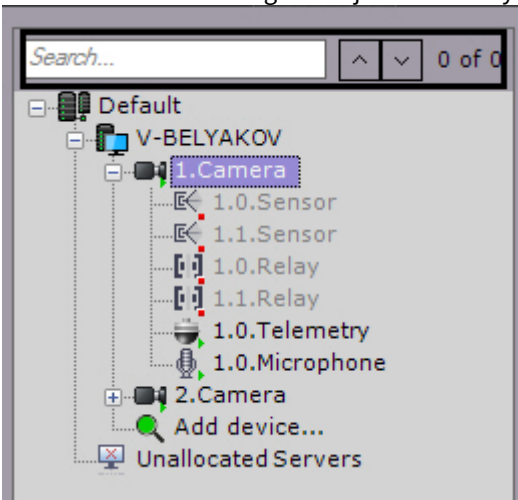

2. Enter the IP address, the full or partial name of the object in the **Search** field.

Note

Search is not case-sensitive

Note

A search can also be run based on object ID

The search starts automatically once you enter something in the box. When the search is complete, you will see the number of objects found in the tree, along with the currently displayed search results highlighted in beige.

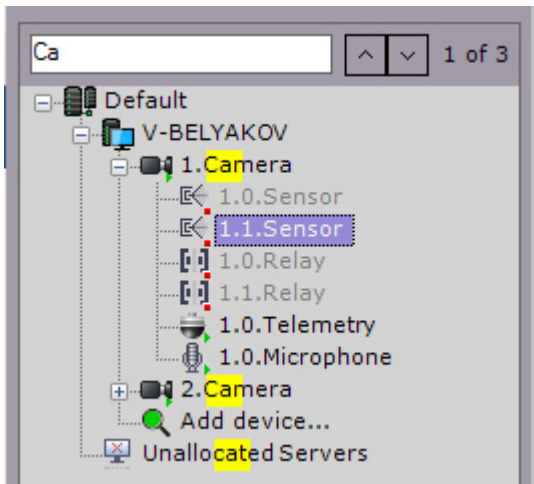

The parts of names corresponding to the characters you entered will be highlighted in yellow on the found objects.

Note

If you search by an IP address, the found object will be fully highlighted.

Note

If a found object is located in a collapsed branch of objects, the branch will be highlighted with a yellow dotted line.

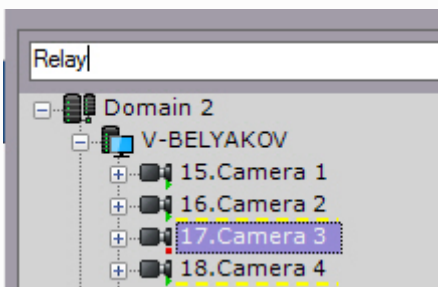

Note

If a found object is located in a collapsed branch of objects, the branch will be highlighted in yellow

You can use the  buttons or press ENTER to navigate through the search results.

The search results rotate in a loop; moving from the last object takes you back to the first object.

Note

If you move to an object located in a collapsed branch, the branch will automatically expand

7.2 Hardware configuration

7.2.1 Configuring Axxon domains

A distributed system based on the Axxon Next software package is created within an Axxon Domain, i.e., a selected group of Axxon Next Servers.

When configuring Axxon Domains, the following operations are used in the necessary combinations:

1. Creating a new domain
2. Adding a Server to an existing Axxon Domain
3. Excluding a Server from the current Axxon Domain

Attention!

You cannot combine regular and Failover Servers within the same Axxon domain (see [Configuring Failover VMS](#)).

To configure Axxon Domains, you must have the appropriate permissions (see the section [Configuring user permissions](#)).

This section gives step-by-step instructions for each operation used in configuring Axxon Domains, and then describes typical instances of their use.

7.2.1.1 Axxon-domain object

The **Axxon-domain** system object is at the base of the system.

The **Axxon-domain** object is the parent of the **Server** objects, which correspond to the servers that are in the Axxon-domain.

When you select the **Axxon domain** object in the **Total devices created** group (1), the software displays information about the Axxon domain and the current license: Servers and their number, IP devices and various used functions.

Also displayed are license serial number (5) and expiration date (6).

Note

The number of created devices means the total number of enabled IP video channels.

The screenshot displays the configuration interface for an Axxon domain. At the top, there are three input fields: 'Enter new domain name' with the value 'Default' (labeled 4), 'License serial number' with a partially obscured value '8...3D' (labeled 5), and 'License expiration date' with the value 'Saturday, August 15, 2020' (labeled 6). Below these fields, the interface is divided into two main panels. The left panel, titled 'Total devices created: 6. Allowed in key file: 5751.' (labeled 1), shows a tree view for the domain 'V-BELYAKOV'. It lists various device types and their counts: 'Devices: 6 from 9', 'Tag-n-Track: 0 from 8', 'Offline analytics: 0 from 1', 'MomentQuest2: 1 from 8', 'Search by LPs: 0 from 8', 'Real-time LP recognition: 0 from 1', 'Face search: 1 from 8', 'Real-time face recognition: 1 from 1', 'Fire detection: 0 from 8', 'Smoke detection: 0 from 8', and 'Event sources: 0 from 1'. The right panel, titled 'Computer/key HID mismatch' (labeled 2), shows '.... Mismatches not found'. Below this, the 'License feature owners' section (labeled 3) lists several features: '12.1.Hall', '12.2.Corridor', '13.3.Stairs', '13.1.Street', and '14.1.Room'.

In the **Computer/Key HID mismatch** (2) group, the license information / error is displayed.

If you select a licensing option in the relevant group (1), the **License feature owners** (3) group will include the objects currently using this license.

You can also rename the Axxon-domain. To do so, enter the new name in the corresponding field (4) and click the **Apply** button.

7.2.1.2 Axxon Domain operations

7.2.1.2.1 Creating a new domain

A new Axxon Domain can be created in one of two ways:

1. During installation of the Axxon Next software package with the Server and Client configuration type (see step 8 of the instructions in the section [Installation](#))
2. When attempting to connect to a Server which does not belong to a domain

In the second case a message will appear, in which you should click **OK** (see also the section [Startup](#)).

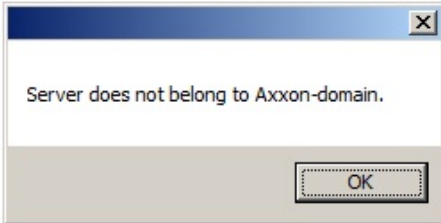

The **Name new Axxon Domain** window will appear. In the **New Axxon Domain name** field, enter the Axxon Domain name to create a new group of computers based on the Server and click **Apply**.



Attention!

It is not possible to use the above steps to add a Server to an existing Axxon Domain. Assigning the same Axxon Domain name to several Servers does not guarantee that those Servers will be in the same Axxon Domain. Different Axxon Domains can have identical names

This will create a new Axxon Domain based on the Server. The Axxon Next software package will then be launched with the entered authorization parameters (see the section [Startup](#)).

7.2.1.2.2 Adding a Server to an existing Axxon Domain

A Server can be added to an existing Axxon Domain from any Server within that Axxon Domain.

Attention!

Before configuring a distributed system, be sure to combine your Servers into an Axxon-domain

Attention!

It is not recommend to use Servers with different versions of Axxon Next on the same Axxon-domain.

Note

Only unallocated Servers, i.e., Servers which do not already belong to any Axxon Domain, can be added

There are two ways to add a Server to an Axxon Domain, depending on whether or not it is present in the search results (in the **Unallocated Servers** group).

If one of these Servers is present in the search results, select it and click the **Add to Axxon-domain** button.

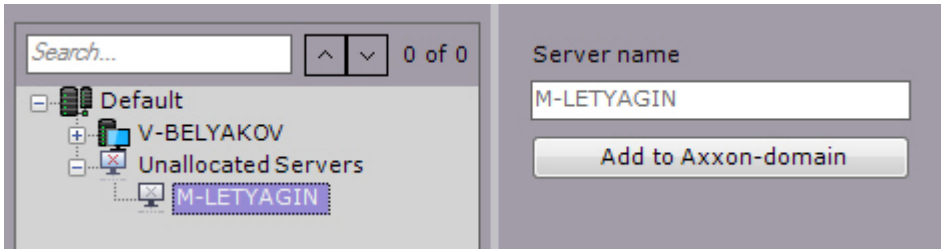

The Server will then be added to the Axxon Domain from the **Unallocated Servers** group. Since the search for unallocated Servers is conducted using broadcast packets, the results may not include Servers located in a different subnetwork (for example, beyond a router which blocks broadcast packets).

In this case the option of manually adding a Server to an Axxon Domain can be useful; this option can be used with all unallocated Servers, including those present in the **Unallocated Servers** group.

A Server can be manually added to an Axxon Domain as follows:

1. Select the **Unallocated Servers** group (1).



2. In the **Server Name** field, enter the NetBIOS name of the Server to be added to the Axxon Domain (2).
3. Enter the Server IP address and port number (3).
4. Click the **Add to Axxon-domain** button (4).

The Server will then be manually added to the Axxon Domain.

After a Server is added to an Axxon Domain using any of the methods described, it will appear in the object tree.

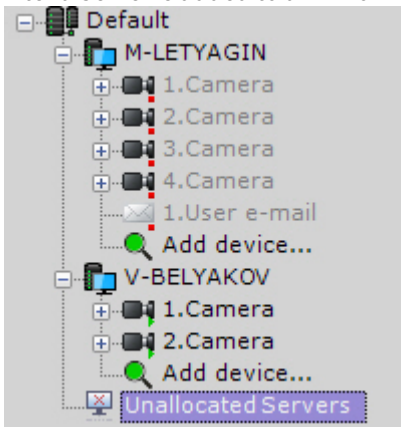

If a Server is not currently accessible when it is added to an Axxon Domain, it will be displayed in the object tree with the  icon.

To undo addition of a Server to the Axxon-domain, select the Server and click the **Exclude from Axxon-domain** button.

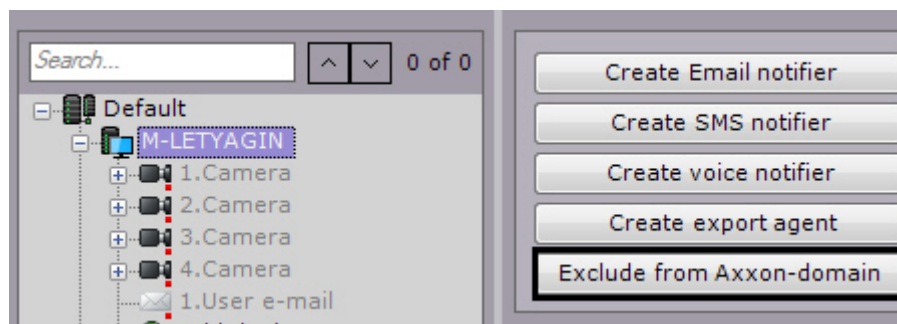

7.2.1.2.3 Removing a Server from an Axxon Domain

Any Server on an Axxon Domain can be used to remove a Server from an Axxon Domain.

Attention!

By excluding a Server, you also delete the macros, layouts, maps, object groups, roles, and users that have been created on the Server

To remove a Server from an Axxon Domain, you must perform the following steps:

1. Select the Server in the list and click the **Exclude from Axxon-domain** button.

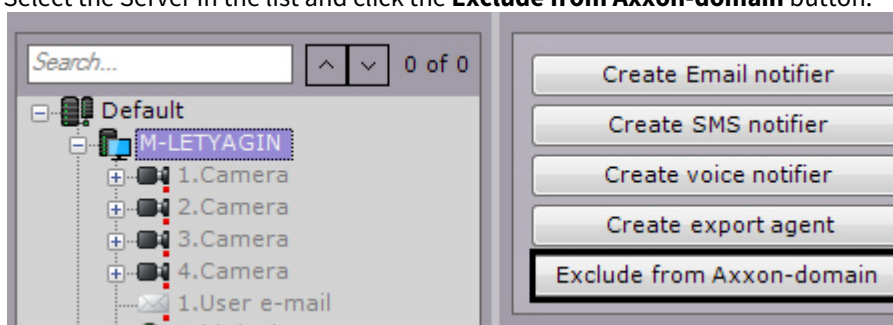

2. In the window which appears, confirm that you want to remove the Server from the Axxon Domain by clicking the **Yes** button.

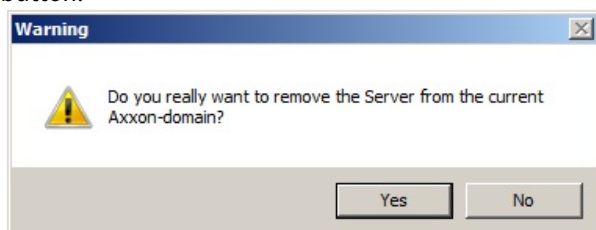

The Server will then be removed from the Axxon Domain. If the current Client was connected to the excluded Server, the user interfaces will be unloaded and the user will be prompted to repeat the authorization procedure for Axxon Next (see the section [Startup](#)).

Note

You can also exclude a Server from an Axxon domain using the activation utility (see [Excluding the Current Server from an Axxon Domain](#)).

7.2.1.3 Cases of Axxon Domain configuration

All possible cases of Axxon Domain configuration are, to some degree, a combination of two typical cases.

In the first typical case, the Servers for the future Axxon Domain are selected before Axxon Next installation. This case involves the following steps:

1. Selecting a Server on the basis of which the new Axxon Domain will be created. Installing the Axxon Next software package with the Server and Client configuration type, indicating the name of the new Axxon Domain (see also step 8 of the instructions in the section [Installation](#)).

Note

Any Server in the future Axxon Domain can be selected as the primary Server

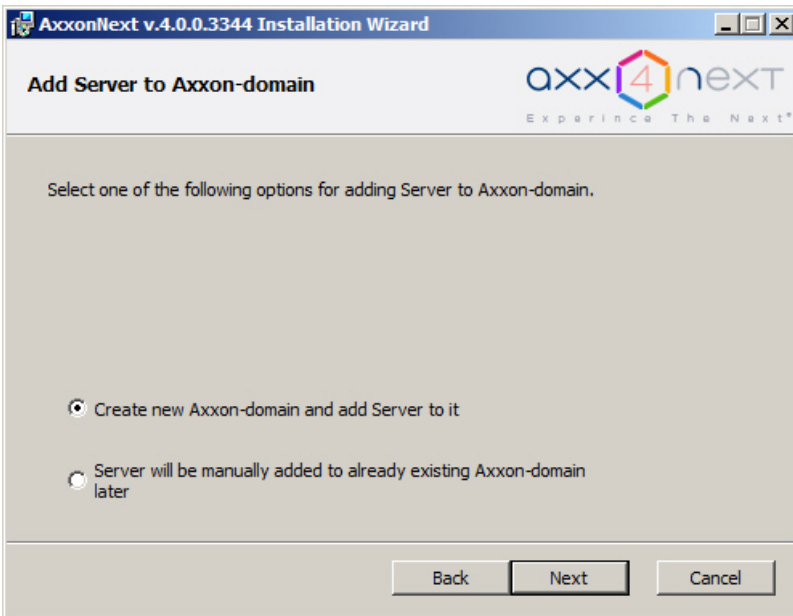

2. Installing the Axxon Next software package with the **Server and Client** configuration type on the other servers of the future Axxon Domain, without adding them to the Axxon Domain (see also step 8 of the instructions in the section [Installation](#)).

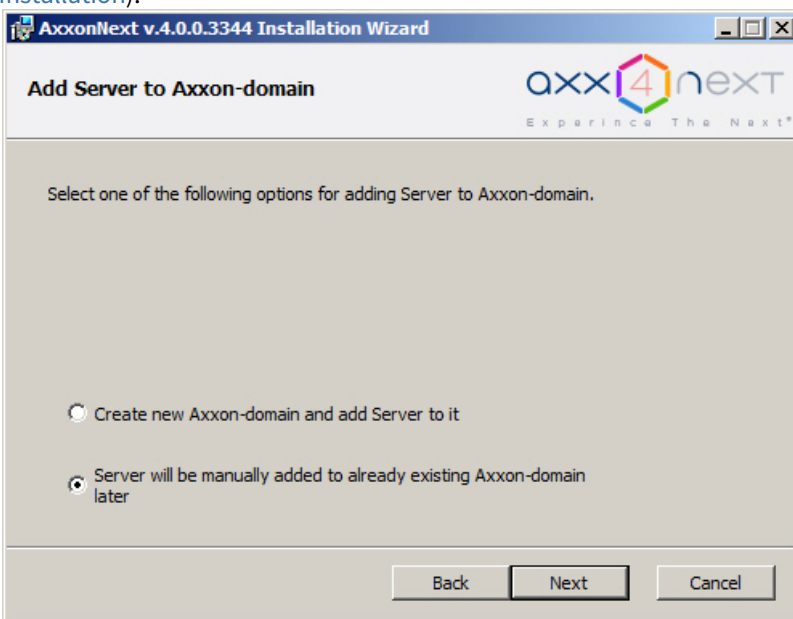

3. Connecting to the primary server.
4. Adding the remaining Servers to the Axxon Domain from the primary Server according to the instructions in the section [Adding a Server to an existing Axxon Domain](#).

In the second typical case it is necessary to add servers which are part of another Axxon Domain to a new Axxon Domain. This case involves the following steps:

1. Excluding all the Servers which are to be added to the new Axxon Domain from their current Axxon Domains, according to the instructions in the section [Removing a Server from an Axxon Domain](#).
2. Naming the new Axxon Domain according to the instructions in the section [Creating a new domain](#), when attempting to connect to one of the Servers excluded in step 1.
3. Adding the remaining Servers to the Axxon Domain from the primary Server according to the instructions in the section [Adding a Server to an existing Axxon Domain](#).

7.2.2 Adding and removing IP devices

You can add video cameras and IP servers to the system by using the IP Device Discovery Wizard.

To open the IP Device Discovery Wizard, click the **Add device** link at the end of the Server device list.

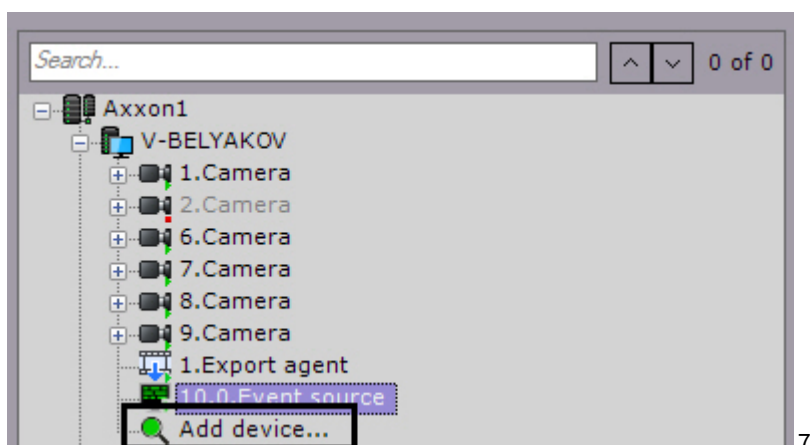

When the Wizard is opened for the first time after the Client is started, automatic search for new devices will begin. During subsequent sessions, to launch the Wizard you must click the corresponding button. A progress bar indicates search progress.

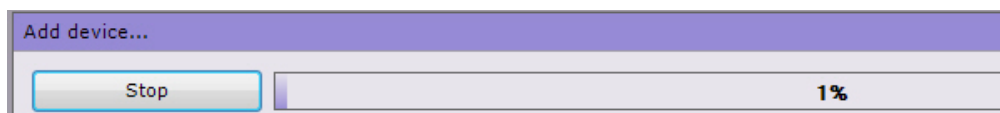

To stop devices search at any time, click the **Stop** button.

Note

Since multicast packets are used for device search, the search results may not contain the Servers and devices from other subnets

The search results are color-coded based on the status of the device.

Color of video camera icon	Description
	Fully supported device
	Manual configuration required
	Axxon Next compatibility not guaranteed

IP address	Port	Vendor	Username	Bind to the archive	ID	Latitude	Longitude
192.168.5.1	80	BS	Auto	Arxiv AliceBlue	Auto	0	0
MAC address		Model	Password	Recording	Name	Azimuth	
A8:55:6A:01:4A:21		IPCAM	****	On motion	Auto	0	
192.168.5.15	80	Axis	Auto	Arxiv AliceBlue	Auto	0	0
MAC address		Model	Password	Recording	Name	Azimuth	
00408C99B2E2		21755	****	On motion/Embedded detection	Auto	0	
192.168.5.37	80	LG	Auto	Arxiv AliceBlue	Auto	0	0
MAC address		Model	Password	Recording	Name	Azimuth	
not defined		LW9228I	****	Always	Auto	0	

Note

If you click the IP address, you will jump to the device web interface.

Search results can be filtered in two ways:

1. By status. To hide devices with a certain status, deselect the relevant checkbox.

Found devices (2):

- Full supported devices
- Manual supported devices
- Unsupported devices

2. By manufacturer, model or IP address. To do this, use the **Filter** field. For example, this filters the **LG** devices, the name of which contains the **LW** model and whose IP address contains **192**.

Add device...

Search

- Unsupported devices
- Manually supported devices
- Fully supported devices

Devices found (3): Filter: LG LW 192

IP address	Port	Vendor
192.168.5.37	80	LG
MAC address		Model
not defined		LW9228I
IP address	Port	Vendor
192.168.5.58	80	LG
MAC address		Model
not defined		LW332
IP address	Port	Vendor
192.168.5.61	80	LG
MAC address		Model
not defined		LW6324

In addition, you can filter cameras from a subnet.

Devices found (6):		Filter: 10.0.11
<p>⚠ Duplicate address/port</p> <p>10.0.11.201 80</p> <p>MAC address not defined</p>	<p>Vendor ONVIF</p> <p>Model generic</p>	
<p>⚠ Duplicate address/port</p> <p>10.0.11.207 80</p> <p>MAC address not defined</p>	<p>Vendor ONVIF</p> <p>Model generic</p>	
<p>IP address</p> <p>10.0.11.208 80</p> <p>MAC address not defined</p>	<p>Vendor JVC</p> <p>Model VN-X35U</p>	

When adding a device, you can immediately set several configuration options, such as:

- manufacturer and model,

Note

You can search by manufacturer and model of the device.

Vendor
Hikvision
Model
ds2012
DS-2CD2012F-I
DS-2CD2012F-IW
DS-2CD2012-I

- login and password,
- ID and object name,

Note

An object identifier must contain: numbers, English characters and the "_" sign.

In the Object Tree, added devices will be sorted by ID.

- Select an archive and set the recording parameters (see [Binding a camera to an archive](#)).
 - **No** - camera is linked to the archive, no recording;
 - **Always** - continuous recording;
 - **On motion** (default setting) - a VMD tool and an automatic rule for writing to the specified archive are automatically created for the camera you are adding. By default, recording stops when an event detection is finished.
 - **On motion/Embedded detection** - an embedded VMD tool and an automatic rule for writing to the specified archive are automatically created for the camera you are adding. By default, recording stops when an event detection is finished.

Note

This option is available only for devices that have on-board VMD.

Note

When creating a new device, the pre-alarm time interval for video footage recording is automatically set to 3 seconds (see [Binding a camera to an archive](#)).

- Camera coordinates (latitude, longitude, azimuth) which are used when the camera is added to the geo map (see [Adding video cameras](#)).

In addition, three modes are available for adding a device to a configuration. These are described in the following table.

	Device addition mode	Description
1	Add device with default settings	The IP device is added to the configuration with the default settings (the default settings are determined by Axxon Next itself). Adding a device in this mode will change the current settings of the device.
2	Add device with current settings	The IP device is added to the configuration with the current settings, as specified in the web interface.
3	Add device with template settings	<p>The IP device is added to the configuration with the settings that have been previously specified for a device of the same model in the configuration. Select a device of the same model (the "template device") in the list.</p> <p>Only devices of the same model are shown in the list of search results for choosing the template device.</p> <p>The following settings will be copied from the template device to the new, similar device: firmware, video stream settings, buffering settings, Other settings (see The Video Camera Object), and Other settings for Microphone and Speaker objects, if these are configured for the template device.</p> <p>This mode is best when multiple cameras of the same model are in use at a site. If this is the case, we advise to:</p> <p>Add and configure one device.</p> <p>Add the remaining devices, copying settings from the "template device" as described previously.</p>

To add an IP device to a configuration:

Set device settings, if necessary.

Select a mode for adding the device to the configuration.

The device is then added to the configuration.

During a single configuration change, you can add a single device or all devices listed in the search results (other than devices for

which compatibility is not guaranteed). To add one device, click the  button. To add all devices, click the **Add all** button.

If you set no individual access parameters while adding hardware, a dialog window appears for setting unified access parameters.

Change credentials

Enter credentials for all cameras:

Username:

Password:

Note

To remove a device from the search results, click the  button.

Note

Remember that if you add all IP devices at the same time, the same mode and settings will be applied to all of them.

If an IP device is not shown in the search results (because it is located on another subnet or contact has been temporarily lost), you can add it manually. To do so, in the neutral-colored area above the search results, select the type of IP device that you are adding (with or without edge storage), specify an IP address and port, and select the manufacturer and model.

IP	Port	Vendor	
<input type="text" value="0.0.0.0"/>	<input type="text" value="80"/>	<input type="text" value="iZett"/>	
Device Type		Model	Firmware
<input type="text" value="VideoDeviceInfoCategory"/>		<input type="text" value="HR-FD2030C"/>	<input type="text" value="VC1.0.18..."/>

Then add the device to the configuration by following the steps described previously.

To remove IP devices, select them in the device list (by left-clicking one or more devices, holding down the CTRL key to select multiple devices) and click the **Delete** button.

If you click the IP address, you will jump to the device web interface.

7.2.2.1 Bulk creation of IP devices

You can add IP devices in bulk by importing their parameters from a CSV file.

Attention!

You have to disable the UAC first.

Do the following:

1. Create a CSV file with devices listed as follows:

IP address, Port, Manufacturer, Model, Login, Password, Identifier, Object name, Latitude, Longitude, Azimuth, Archive name, Recording mode

Attention!

For each added camera, three parameters are required: IP address, Make and Model.
 If a required parameter is not specified, it will be automatically set to its default value.
 You should include commas even if no additional parameters are set.

For example:

```
10.0.12.245, 80, Bosch, Dinion IP starlight 8000 MP, service, Admin12345!, 1441, Camera 1,
0, 0, 0, Archive AliceBlue, Always
10.0.12.246,, Bosch, Dinion IP starlight 8000 MP,,,,,,
10.0.12.247, 80, Bosch, Dinion IP starlight 8000 MP,,, Camera 3,,, Archive AliceBlue, On
motion
```

Attention!

The manufacturer and model of the device must be specified exactly as in the [list of supported devices](#).

Note

For correct display of the object name in *Axxon Next* VMS, the CSV file must be UTF-8 or UTF-32 encoded.

2. Drag & drop the created file to the field in IP Device Discovery Wizard in *Axxon Next*.

IP address 0.0.0.0	Port 3600	Vendor 360Vision	Username Auto	Bind to the archive AliceBlue	ID Auto	+
Device type IP device	Model Predator Pred-XX-IP		Password ****	Recording On motion	Name Auto	

The devices will be added to the configuration.

7.2.3 Configuring System Objects for Devices

7.2.3.1 The Server Object

The **Server** object corresponds to a computer a) on which Axxon Next is installed in the **Server and Client** configuration and b) is on the Axxon-domain.

The name of the **Server** object is the same as the computer's network name.

The **Server** object is the parent of the **Camera** and **IP server** objects, which correspond to the hardware connected to the Server.

Click the **Server** object to view the following information:

1. buttons for creating a system speaker or SMS and email notifications; button for excluding the Server from the Axxon-domain, and button for launching the Configuration management utility (1).

The screenshot shows the configuration interface with several key sections:

- 1** Buttons for actions: Create export agent, Exclude from domain, Create voice notifier, Create SMS notifier, Create Email notifier.
- 2** Server information: Server (V-BELYAKOV), Server version (4.5.0.473), AxxonNext Client (4.5.0.473 x64), Driver pack (3.69.3658), Server status (Active server), License status (Unknown - Active license file of the demo mode).
- 3** Web-server properties: Certificate file, CORS (No), Enable (Yes), Port (80), Private key file, RTSP port (554).
- 4** Devices connected: 1. A table with columns: Name, IP address, Vendor, Model, Geolocation, Azimuth. One camera is listed: 1.Camera, 0.0.0.0, AxxonSoft, Virtual severa..., 0.

2. Information on the installed version of Axxon Next and active license (2).
3. Web server configuration options (3, see [Configuring the web server](#)).
4. List of cameras connected to the Servers, including main settings (4).

Note

The number of connected devices means the total number of available IP video channels, including disabled.

The list of cameras is shown as a table with the following columns: **Name, IP address, Vendor, Model, Quality, Video codec, Frame rate** and **Resolution**.

The table can be sorted by any of the columns.

Note

If no cameras have been created on a Server, you are prompted to search for IP devices on the network (the IP Device Discovery Wizard is launched, see [Adding and removing IP devices](#)).

If a camera supports multistreaming, the information in the **Quality, Video codec, Frame rate** and **Resolution** columns will be displayed as follows> value for the lowest-quality stream/value for the highest-quality stream.

Devices connected: 2							
Name	IP address	Vendor	Model	Quality	Video codec	Frame rate	Resolution
2.Camera	10.0.11.207	Sony	SNC-ER580	High	jpegWithBandwidthControl	20	640x480
1.Camera	10.0.11.201	Sony	SNC-VB630	Low/High	H264_6generation_maxBitrate_8kbps/H264_6generation	30/30	640x480/1920x1080

7.2.3.1.1 Configuring the web server

The web server allows accessing Axxon Next remotely over the Internet (see [Working with Axxon Next Through the Mobile Clients](#), [Working with Axxon Next Through the Web Client](#)).

Attention

On the local computer with the Web server running, ports from the range [9001; 9001 + number of logical cores of the processor] must be open.

Attention

The web server recodes incoming non-H.264 videos into MJPEG format, therefore the incoming traffic may increase dramatically.

To configure the web server in the *Axxon Next* software package:

1. Select a **Server** object.

Web-server properties		
1	Enable	Yes
2	Port	81
	Private key file	
	RTSP port	554
	RTSP/HTTP port	8554
	SSL port	0
3	URL path	/

2. If you want to disable the web server, set the value of **Enable** to **No** (1).
3. In the **Port** field, enter the port number on which the web server will be located (2).
4. In the **URL path** field, enter the prefix that is added to the server address (3).
5. To connect to a web server via the HTTPS protocol, do the following:
 - a. Specify a path to the certificate (1).

Web-server properties		
1	Certificate file	
	Enable	Yes
	Port	81
2	Private key file	
	RTSP port	554
	RTSP/HTTP port	8554
3	SSL port	0

Attention!

Axxon Next supports TLS encryption v1.2 and 1.3 with AES GCM, AES CCM and AES CBC algorithms.

- b. Specify a path to the private key (2).
 - c. Enter a port number to connect to the HTTPS server (3);
6. Click the **Apply** button.

The web server is now configured and available over the Internet at the following address: `http://<IP address of Axxon Next Server>:<Port>/<Prefix>`. For example, if the server's IP address is **10.0.11.1**, the port is **8000**, and the prefix is **/asip-api**, then the web server can be accessed at the following address: <http://10.0.11.1:8000/asip-api>.

7.2.3.1.2 Configuring an RTSP Server

Axxon Next supports RTSP streaming from cameras (see [Get camera live stream](#) and [Get archive stream](#)).

To configure an RTSP Server:

1. Select a **Server** object.
2. In the **RTSP port** field, specify the port number that will be used for RTSP data transfer (1).

Web-server properties		
	Port	80
1	RTSP port	554
2	RTSP/HTTP port	8554
	URL-path	/
RTSP port		
Specify RTSP port.		

3. In the **RTSP/HTTP port** field, specify the port number for transfer of RTSP data via HTTP tunnel (2).
4. Click the **Apply** button.

Configuration of the RTSP Server is now complete.

To receive videos from an RTSP server, use the following link format:

- **Live** rtsp://login:password@IP-Address:554/hosts/HOSTNAME/DeviceIpint.N/SourceEndpoint.video:0:0 - high quality stream
rtsp://login:password@IP-Address:554/hosts/HOSTNAME/DeviceIpint.N/SourceEndpoint.video:0:1 - low quality stream
- **Archive** rtsp://login:password@IP-Address:554/archive/hosts/HOSTNAME/DeviceIpint.N/SourceEndpoint.video:0:0/20160907T050548.723000?speed=1

where:

- **login:password** - user login and password in the *Axxon Next* VMS.

Attention!

For correct operation of the RTSP Server, a user name has to match the following rules:

- start with a letter;
- contain only Latin, numerical and following extra characters: "/", "-", "_", ".", ":", "+".

- **hosts** - permanent section of a link.
- **HOSTNAME** - server name.
- **N** - camera ID in the *Axxon Next* VMS.
- **SourceEndpoint.video:0:0** - permanent section of a link.
- **speed** - a parameter required for receiving video streams from an Archive.

7.2.3.2 The Video Camera Object

Creation and configuration of the **Video camera** object is done in the **Hardware** tab. The object tree of a video camera is generated automatically according to its functions which are integrated into the *Axxon Next* software package (the presence of alarm inputs, relay outputs, PTZ unit, etc.).

Note

You can configure recording options for a camera in the corresponding tab (see [Configuring Archives](#)).

When you have added a camera via the IP Device Discovery Wizard (see [Adding and removing IP devices](#)), you can edit the camera's parameters. The camera parameters are grouped as follows.

In the **Object identification** group, you can see the camera ID, and you can enter a camera name / short name and text comments.

Object identification	
Enable	Yes
Name	Camera
Comment	

Note

You may use camera's short name in hotkeys (see [Notes regarding hot key actions](#)).

Note

By default, the short name is a camera's ID. The full name of the video camera in the object tree is displayed in the <Short name>. <Name> format.

After changing the short name and restarting the Client, the cameras in the object tree will be sorted by their short names.

Also, you can disable the camera by selecting **No** in the **Enable** field.

Attention!

In terms of licensing, every camera enabled is one channel. Disabled cameras are not subject to licensing (see [Licensing of the software product](#)). If you run out of camera licenses, disable offline / unused cameras.

In the **Object features** group you can see the following camera properties:

1. The IP address (assigned automatically and can be changed if necessary).

Note

The port used to transmit data between the camera and the Axxon Next VMS (this value is set to 80 by default but can be changed if necessary).

2. At first the port number is set through the camera's Web interface.
3. Camera positioning coordinates (latitude, longitude, azimuth).
4. The MAC address.
5. Manufacturer, model, firmware.
6. The number of the video channel (for an IP Server).
7. Device serial number (for Axis devices only, see [Axis IP Devices](#)).

Object features	
Address	0.0.0.0
Port	80
MAC address	
Manufacturer	AxxonSoft
Model	Virtual several streams
Driver version	3.0.0
1 Break unused connections	No
Current firmware	
Device serial number	
2 Low GOP	No

You can also customize a number of options shared by all video cameras in this group:

1. If you want to interrupt video streaming from the camera to the Server whenever it is not needed, select **Yes** for **Break unused connections (21)**.
 Conditional interruption of video transmission from a camera to the Server, if:
 - a. the video stream is not displayed on either Client or web client layout.
 - b. the stream is currently not being recorded into Video Footage.
 - c. the stream is currently not being processed by any detection tool.
2. After starting the Client, the default setting is to display video only after the first I-frame (key frame) is received. If the stream comes with a relatively long GOP length (Group of Pictures) or GOV length (Group of Video Object Planes), e. the number of P- and B-frames between I-frames in the stream, the video may be not available for a minute. In this case, select **Yes** for the **Low GOP** keyframe rate setting (2). This will reduce the waiting time for video by pushing the preceding I-frame that can be stored in the memory buffer on the Server. In some cases, the I-frame will not be buffered, but in most cases this means that it will soon be received from the device.

In the **Authentication** group, you can set the username and password to connect to the camera.

Authentication	
Default	No
Login	admin
Password	•••••

If the username and/or password for connecting to the camera are different from the factory settings, select **No** in the **Default** field and enter the current credentials.

Attention!

If the camera supports the Digest HTTP-authorization, add the symbol " : " to the last character of the password.

To enable video buffering on Clients, set the buffer length in milliseconds in the **Video buffering** group.

Video buffering	
Buffer size	0

This value should be between 50 and 1000 milliseconds. If the value **0** is selected, video buffering is disabled.

In the **Camera settings** group you can see video image parameters (contrast, brightness, color saturation, etc.). When configuring these, you can look up short parameters' descriptions in Axxon Next GUI. For more detailed information, please refer to the camera manual.

Video stream settings	
Brightness	50
Color Saturation	50
Contrast	50
Day/Night Autoswitch Time	50
Exposure Mode	Auto
Flicker-free	50
Image Flip	None
IR Cut Filter Sensitivity	Medium level
IR Cut Filter	Auto
Sharpness	50
Shutter Speed	1/50
WDR Level	0
White Balance	AWB1
Wide Dynamic Range	None

Note

If you set up a camera via its web page, you cannot edit the parameters in the VMS (see [Adding and removing IP devices](#)). To configure the camera in the VMS, select the **Send settings to device** checkbox.

You can configure fisheye cameras in the **Panomorph** group.

Panomorph	
Activate	No
Camera position	Wall
Lens type	A0**V
View type	PTZ

Select a standby / substitute camera from the current Axxon domain in the **Alternative view** list. The sub camera shows in the layout when the main camera is offline.

Alternative view	
Alternative camera 1	27.Camera
Alternative camera 2	28.Camera

Then you can configure them to show the nearest cameras to the alerted one (see [Configuring Alerted Cameras layouts](#)).

You can configure video streams under the viewing tile. If a camera supports multistreaming, you can configure two video streams separately: high quality and low quality. When creating an IP device with a high quality video stream, a stream with a higher resolution is selected.

To configure video streams, you should make sure that the **Send settings to device** checkbox is selected.

An adaptive video stream can be configured if necessary (see [Configuring an Adaptive Video Stream](#)).

Note

In most cases, the following parameters are set for video streams: bit rate, compression rate, frame rate, and resolution. Detailed information on configurable parameters can be found in the official reference documentation for the video camera.

High-quality video stream	0. H.264/MPEG4
Audio	Yes
Bitrate	8192
Compression Mode	Variable bitrate
Frames per second (fps)	12
Keyframes Interval	25
Quality	Medium level
Resolution	1280 x 720
Transport Protocol	TCP
Video Codec	H.264
Low-quality video stream	1. H.264/MJPEG/MPEG4
Audio	Yes
Bitrate	4096
Compression Mode	Variable bitrate
Frames per second (fps)	12
Keyframes Interval	25
Quality	Medium level
Resolution	352 x 288
Transport Protocol	TCP
Video Codec	H.264

To configure video streams, use the settings available in the Axon Next interface, not the web interface of the camera itself.

If you are using the web interface to configure camera's video streaming, you have to set the expected fps value to have the stream parameters correctly displayed (see [Viewing camera status](#)).

You can alter video stream settings by sending an HTTP request to the device (see its manufacturer's documentation) through some macros (see [Executing a web query](#), [Starting an external program on Servers](#), [Starting an external program on Clients](#)).

High-quality video stream	0. H.264
Bitrate	512
Compression mode	Variable bitrate
Expected frames per second (fps)	30
Keyframes interval	15
Quality	Medium level
Resolution	QXGA (2048 x 1536)
Transport protocol	TCP
TV standard	NTSC
Video codec	H.264
Low-quality video stream	1. H.264
Adaptive video stream	Disabled

Important

You can any select any stream for live view or recording (see [Selecting video stream quality in a viewing tile](#), [Binding a camera to an archive](#)).

If a camera does not support multistreaming, the parameters of the video streams are identical. In this case only the parameters of the high-quality video stream are editable (the parameters of the low-quality video stream are adjusted automatically).

Note

When some video stream parameters are changed, the video camera may automatically restart, in which case it will become unavailable for some time (depending on the video camera)

Image from the camera will be displayed in the preview window.

4.Camera		High-quality video stream	Low-quality video stream
Object identification			
Enable	Yes		
ID	4		
Name			
Object features			
Address	10.0.11.207		
Port	80		
MAC address			
Manufacturer	AxxonSoft		
Model	Virtual several streams		
Driver version	3.0.0		
Current firmware	auto		
Video channel No.	0		
Authentication			
Default	Yes		
Login			
Password	****		
Video buffering			
Buffer size	0		
Panomorph			
Activate	No		
Camera position	Wall		
Lens type			
View type	PTZ		
Alternative view			
Alternative camera	Not selected		

Note

The indicator in the upper right corner displays the current time and recording status (see [Time Display](#)).

To switch between streams in the preview window, click the **High-quality stream** and **Low-quality stream** tabs.

Note

When a stream is selected in the preview window, the settings for the relevant stream are displayed; settings for the other stream are hidden.

7.2.3.2.1 Restoring default camera settings

You can restore the default Axxon Next settings for a camera.

Current camera settings will be discarded and replaced with the defaults.

To restore default camera settings, select a camera in the device list. Click the **Reset** button and then the **Apply** button.



7.2.3.2.2 Mass configuration

You may bulk configure cameras of the same model and firmware. Do the following:

1. Configure any camera.

- Click the  button and select cameras the same settings should be applied to.

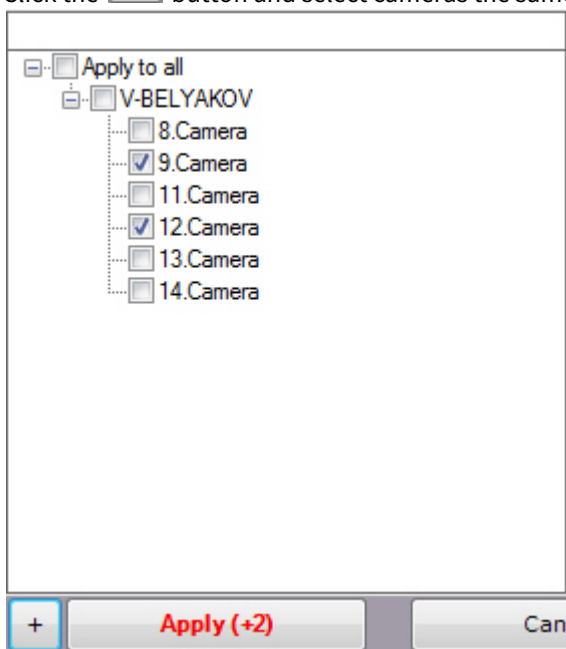

A list of cameras of the same model and firmware opens. To quickly select multiple cameras, hold down the Shift key, select the first and last cameras the settings should be applied to. Selecting any camera from highlighted ones will result in selecting them all.

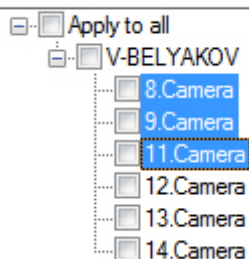

- Click the **Apply** button.

Note

The number in brackets refers to the number of configured cameras.

7.2.3.2.3 Configuring an Adaptive Video Stream

It is possible to convert the original video stream into the Motion Wavelet format with adaptive parameters.

Bitrate and fps of such a video stream will vary depending on the current situation: Server load, channel bandwidth and requested video stream resolution.

To configure an adaptive video stream, perform the following steps:

- If the video camera supports simultaneous transmission of several video streams, select the video stream to be converted into the Motion Wavelet format in the Adaptive Video Stream list.

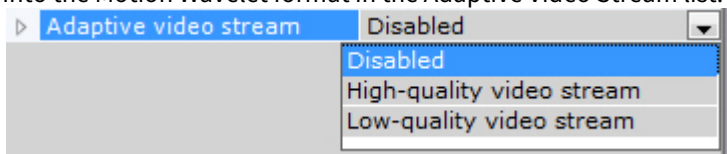

If the video camera is single-channel, select **Yes** in the **Adaptive Video Stream** list.

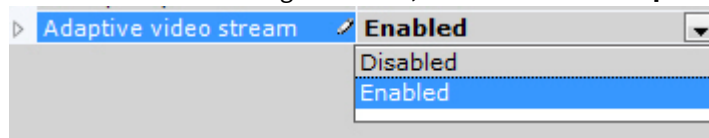

- Set the required resolution of an adaptive video stream, if necessary.

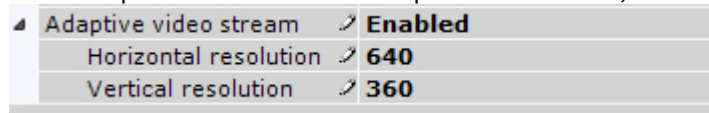

If you specify resolution on only one side, then a scaling step that does not exceed the specified number is selected. If you enter resolution values for both dimensions, the compressed frame will be displayed in the designated rectangle with the constrained proportions.

Note

Axxon Next server scales the adaptive video stream to 2, 4, 8, and so on.

For example, if you select the horizontal resolution **680** for a **1280x720** stream, the adapted video be **640x360**.

If the dimensions are not set (**0** value), then the adaptive video stream will have the same resolution as the original video stream.

- Click **Apply** to save the changes.

Configuring an adaptive video stream is complete.

7.2.3.2.4 Configuring fisheye cameras

If you are using a fisheye camera or video camera with a panomorph lens, configure the following settings of the **Video camera** object, in the **Panomorph** settings group:

- To activate panoramic view, in the **Activate** list **(1)**, select **Yes**.

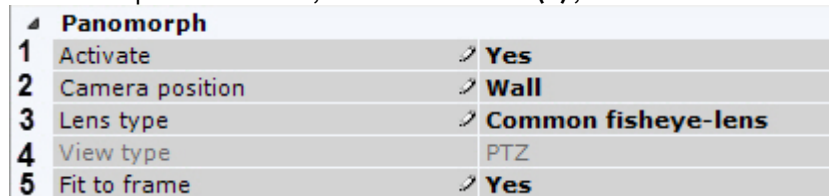

- In the **Video camera position** list **(2)**, select the mount of the video camera.

Important!

Some system features and functions depend on the chosen position of the video camera: digital zoom, display of video in the surveillance sector on the map, and immersive mode

- If it is a fisheye camera, select the **Common fisheye-lens** lens type **(3)**. If it is a video camera with a panomorph lens, select the corresponding type **(3)**. When using wide angle dual lens XingYun devices, select the **Double sphere fisheye-lens** type.

Note

The types of device lenses certified by ImmerVision are listed in the [document](#).

You cannot select ImmerVision lenses in Linux.

- If it is a video camera with an ImmerVision lens, select the appropriate display mode **(4)**: 360° panorama with virtual PTZ (**PTZ**) or 180° panorama (**Perimeter**).
- A typical fisheye lens with standard settings produces a skewed image in the upper part of the screen. If this is the case, enable the **Fit to frame** option **(5)**.

Important!

If you have multiple streams from a camera, you need to calibrate each stream. To do this, before applying the settings, switch to the required stream tab in the viewing tile (see [The Video Camera Object](#)).

Important!

Video is calibrated every time you change any parameters in the **Panomorph** group.

Manual calibration is also available. To do this:

- Disable **Fit to frame**, select **No** in the **Enable** list and click the **Apply** button.
- Select **Yes** in the **Enable** list.
- Configure the video area (circle). Left-click any point inside the circle and move the mouse pointer. To change the diameter of the circle, do as follows: click an anchor point  and move the mouse pointer.

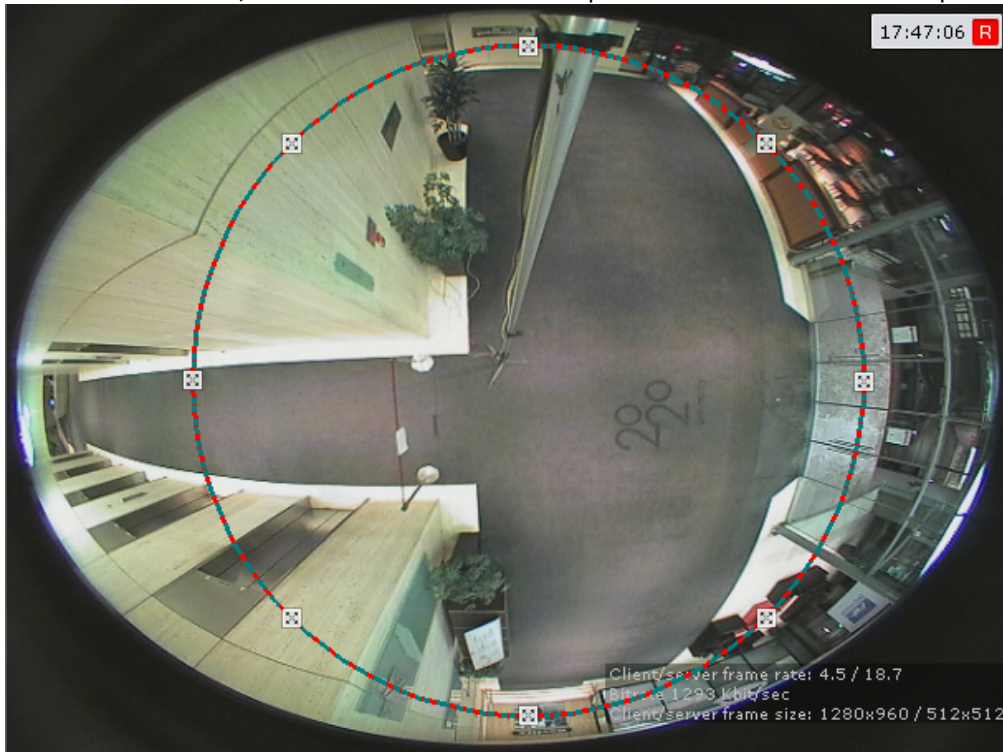

- Click the **Apply** button.
After applying the settings, the area outside the circle will be cut.

Configuration of the fisheye camera is complete.

7.2.3.2.5 Connecting and configuring cameras over standard protocols

7.2.3.2.5.1 Notes on configuring video cameras connected via ONVIF

On page:

- [Connection through ONVIF Generic driver](#)
- [Resolution](#)
- [IP devices on other subnets \(behind a NAT\)](#)
- [IP devices which partially support the ONVIF protocol](#)

By default, all ONVIF devices in the system are added as multistreaming (the **ONVIF 2.0** driver, see [Adding and removing IP devices](#)).

If the camera does not support multistreaming, then the video stream of lower quality will be disabled.

Note

In some cases (for example, if you do not have video from a camera), you may need to synchronize the time between the server and the camera when you connect them via ONVIF.

Attention!

If you connect cameras via ONVIF, auto focus (AF) and auto aperture are not available

Connection through ONVIF Generic driver

With the ONVIF Generic driver, you have the following options:

1. **Currently offline cameras can transfer their settings when they get back online.**
 To make it happen, follow the steps below:
 - a. Add a camera via the ONVIF Generic driver (see [Generic Drivers \(General device, generic\)](#)).
 - b. When the device comes online, reset its parameters (see [Applying and resetting settings](#)).
 - c. Load the configuration from the device (see [Applying and resetting settings](#)).
2. **You can select another camera in object settings while keeping all layouts, macros and archive storage parameters.**
 To make it happen, follow the steps below:
 - a. Add a camera via the ONVIF Generic driver (see [Generic Drivers \(General device, generic\)](#)).
 - b. Set archive storage parameters and create macros.
 - c. In **Camera** object settings, specify a new IP address and user credentials (see [The Video Camera Object](#)).
 - d. Reset device settings (see [Applying and resetting settings](#)).
 - e. Load the configuration from the device (see [Applying and resetting settings](#)).

This operation will result in swapping cameras without the need to create a new object and remove the old one.

Resolution

Axxon Next offers three resolutions for video from cameras connected via ONVIF: maximum, medium, and minimum.

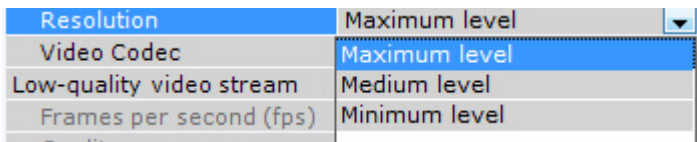

A description of the resolution levels is given in the table.

Camera type / Resolution	Maximum	Medium	Minimum
Non-megapixel	Maximum camera resolution	Average camera resolution	Minimum camera resolution
Megapixel	Maximum camera resolution	Camera resolution closest to 1024x768	Camera resolution closest to 640x480

IP devices on other subnets (behind a NAT)

By default, **NAT-friendly mode** is enabled for cameras connected via the ONVIF driver.

To disable NAT-friendly mode, in the settings of a camera, select the **No** value for **Overriding IP address**.

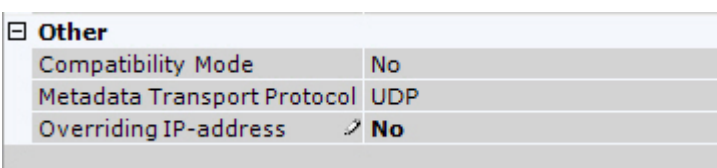

IP devices which partially support the ONVIF protocol

To connect IP devices which only partially support ONVIF functions to the Axon Next software package, you must use an ONVIF driver (1) with compatibility mode enabled.

Note

Such video cameras include Hikvision models and early versions of firmware from Sony, Samsung, and others.

Compatibility mode makes it possible to receive a video image from video cameras; however, some capabilities of the Axon Next software package will be unavailable.

Enabling compatibility mode for a video camera (2) connected using the ONVIF protocol (1) is recommended if the connection settings are correct, but there is no video image.

1	Manufacturer	ONVIF
	Model	1_channel_device
	Driver version	3.0.0
	Current firmware	
	Video channel No.	0
	▶ Authentication	
	▶ Video buffering	
	▶ Video stream settings	
	▶ Panomorph	
	▶ Other	
2	Compatibility Mode	Yes
	Event Source	Yes
	Metadata Transport Protocol	No
	Remapping IP-address	Yes

7.2.3.2.5.2 Configuring connection of video cameras via RTSP

In IP Device Discovery Wizard, add a camera via RTSP with the following parameters:

1. In the list of manufacturers, select **RTSP (1)**.

IP address 2	Port	Vendor
rtsp://root.root@10.0	80	RTSP 1
Device type		Model
IP device		RTSP Device
		Firmware
		auto

2. URL of the RTSP feed (2). In general form, the address is as follows: **rtsp://<IP address of RTSP server>:<Port on RTSP server>/<Path>**.

Up to three simultaneous video streams are supported from RTSP-connected cameras. To access multiple streams, enter the relevant RTSP addresses, placing a semi-colon (;) after each address: **rtsp://<IP address of RTSP server1>:<Port on RTSP server1>/<Path>; rtsp://<IP address of RTSP server2>:<Port on RTSP server2>/<Path>; rtsp://<IP address of RTSP server3>:<Port on RTSP server3>/<Path>**.

Important!

Generally, RTSP server parameters (port and path) are set through the web interface of the video camera. To do so, refer to the manufacturer's documentation for the video camera

Important!

If the username and/or password contain forbidden characters, such as "@", you have to escape these characters with relevant ASCII codes to avoid log-in problems. The "@" symbol is escaped as %40. For example, for a successful RTSP connection your device's URL may look like this: "rtsp://admin:New%40edge@192.168.0.75:554/RVi/1/1".

Note

In some cases, the address format may be different. For example, a user name and password may be added to the address for connecting to the video camera.

2. Object features	
Address	rtsp://root:root@10.0.11.121:
Driver version	3.0.0

You are advised to refer to the manufacturer's documentation for the video camera.

Even if the password field is empty, the address string must include a colon (:).

A correct address may look like this: rtsp://user:@10.10.27.50:10017/...

An example of an incorrect address: rtsp://user@10.10.27.50:10017/...

The **Video camera** object is created. If the address of the RTSP server is correctly specified, the video feed from the camera is shown in a preview tile.

Note

Port, Login and Password can not be edited. These settings are specified in the URL of the feed.

If video is unavailable, examine the log file *APP_HOST.lpint*, which is located in the folder <Axxon Next installation folder>\AxxonNext\Logs.

Important!

If APP_HOST.lpint is empty, in the log management utility, check the detail level of logging for the Axxon Next Server (see [Configuring Logging Levels](#)), The recommended detail level is **Debug**.

Since Drivers Pack version 3.62.2953, RTSP streaming over HTTPS is supported. To set this option, set the **Transport Protocol** parameter to **rtspoverhttps**.

High-quality video stream	0. Auto
Expected frames per second (fps)	30
Message for keepAliveCommand property	OPTIONS
npt range format	npt=now-
Resolution	Auto
SSRC filter	Yes
Transport protocol	rtspoverhttps
Video codec	Auto
Low-quality video stream	1. Auto
Adaptive video stream	Disabled

Important!

To get good video from some cameras, you should select **No** for the **SSRC filter** in the video settings

High-quality video stream	0. Auto
Expected frames per second (fps)	30
Resolution	Auto
SSRC Filter	No

7.2.3.2.5.3 Connecting cameras via the GB/T28181 protocol

On the page:

- [General information on GB/T28181 standard and supported functions](#)
- [Configuring an IP-device to operate via GB/T28181 standard](#)
- [Configuring IP-device connection via GB/T28181](#)

General information on GB/T28181 standard and supported functions

Axxon Next supports connecting devices via the Chinese standard GB/T28181. This standard is based on SIP over UDP (and over TCP since GB/T28181-2016). The GB/T28181 uses the following protocols over SIP:

- SDP (Session Description Protocol)
- MANSCDP (Monitoring and Alarming Network System Control Description Protocol)
- MANSRTSP (Monitoring and Alarming Network System Real Time Streaming Protocol)

This allows receiving the status of sensors, events from detectors, PTZ and relays control, access the built-in archive of the IP device (make sure to set the correct device time zone in the *Axxon Next*), etc. within the SIP session. Single-channel and multi-channel devices in single-stream mode and working with the UDP and TCP transport protocols is also supported.

At the same level of the OSI model, the RTP/RTCP protocol also works in parallel with the SIP protocol, which makes it possible to use the following functions:

- video transmission (including archival) in H264, H265, or MJPEG format.
- audio transmission in G.711a, G.711u, or G.726 format in PS (Program Stream) only. Archive audio is not supported.

For the most up-to-date information on this standard and the features supported in *Axxon Next*, see the [Documentation Drivers Pack](#).

Configuring an IP-device to operate via GB/T28181 standard

Configuration of IP devices connected via GB/T28181 is performed through the web interface of the devices. Settings are not sent from *Axxon Next* to the device.

Before connecting a camera via this protocol to Axxon Next, perform the following steps to configure SIP on the device:

1. Set the Server IP to equal the Server's IP address.
2. Set the Server port (5060 by default).
3. Set the Device ID. The ID should be set on all cameras connected via the GB/T28181 protocol and must be unique. The format of the connection code (device ID and server ID) is a 20-digit number:
 - a. the first 10 digits specify the address (according to the GB/T-2260-2007 standard);
 - b. the next 10 digits indicate device information.

If the IP device is located behind NAT, then forward and explicitly specify the external address of the Server, the port/port range for receiving video, and the SIP port of *Axxon Next* Server. Example:
3402000001110000001/50557-51557@10.3.3.11/85.172.174.36
4. For the device to perform autodiscovery of the Server more quickly, reduce the default value of RefreshRegTime. The name of this setting may vary on some cameras.

Note.

For telemetry to work correctly, set RefreshRegTime to more than 600.

[Examples of IP device settings for connection via GB/T28181 standard](#)**Configuring IP-device connection via GB/T28181**

Important!

No more than one SIP server can be used for IP devices connection via the GB/T28181 protocol. This means that several **Video Capture Device** objects with **GBT28181** type can be created in the *Axxon Next* hardware tree, however, the part of the address after @ must match for all of them. The server ID, local address, external address, and port must be the same for all devices. If at least one parameter is different (for example, the local IP address is not set for some device when it is set for other devices), then such a device will not start.

Note.

Axxon Next does not support auto-discovery of devices connected via GB/T28181 and these devices are not added using the Camera discovery tool.

After configuring the device as described earlier, add it to Axxon Next as follows:

1. Run the IP discovery wizard (see [Adding and removing IP devices](#)).
2. In the form for manually adding an IP device, in the **Vendor** list, select **GBT28181 (1)**.

IP address 2	Port 3	Vendor 1	Username 4
<input type="text" value="34020000001320000000"/>	<input type="text" value="5060"/>	<input type="text" value="GBT28181"/>	<input type="text" value="Auto"/>
Device type		Model	Password
<input type="text" value="IP device"/>		<input type="text" value="1 channel device"/>	<input type="text" value="••••"/>

3. In the **IP address** field specify the value of Device ID parameter set during IP device configuration (2). The following additional parameters can be specified optionally as follows:
`[gbt://]deviceID[/videoPort]@serverID[-serverLocalIP[/serverExternalIP]]`
OR
`[gbt://]deviceID[/videoPortFirst-videoPortLast]@serverID[-serverLocalIP[/serverExternalIP]]`
where:
deviceID is the Device ID parameter;
serverID is the identifier of the *Axxon Next* Server generated according to the same rules as the IP device ID (see above).
videoPort is the port for receiving video;
videoPortFirst - videoPortLast is range of ports for receiving video;
serverLocalIP is the local IP address of the *Axxon Next* Server, which sets the network interface on which the Server should be available;
serverExternalIP is the global IP address of the *Axxon Next* Server; this parameter is in use when the *Axxon Next* Server is behind the gateway. In this case, this IP address is specified as the SIP Server IP address in the IP device settings.

Examples.

```
340200000013200000008@34020000002000000001
340200000013200000008@34020000002000000001-10.0.40.246/113.125.160.58
340200000013200000008@34020000002000000001-10.0.40.246
340200000013200000008@34020000002000000001-/113.125.160.58
340200000013200000008/50200@34020000002000000001
340200000013200000008/50200-50210@34020000002000000001-10.0.40.246
```

4. In the **Port** field, enter the local port number that the *Axxon Next* Server shall listen for receiving messages from the IP device (3). Usually this is the default SIP port: 5060.

Note.

The IP device SIP port is detected automatically.

5. The **Username** and the **Password** fields are not used (4).
6. Click the



button.

Connection of the camera via GB/T28181 is now complete.

Examples of IP device settings for connection via GB/T28181 standard

On the page:

- [Jovision](#)
- [Bosch](#)
- [Huawei](#)
- [Hikvision](#)
 - [GB/T28181-2011](#)
 - [GB/T28181-2016](#)
- [Dahua](#)

Examples of IP device settings and connection settings in Axxon Next for GB/T28181 standard are given below.

Note

The protocol is usually supported by cameras for China market not having any English interface. This is why some of the screenshots below are given in Chinese.

Jovision

Configure a Jovision camera for operation via GB/T28181 standard as follows:

1. Perform the following settings of the IP-device:
 - a. Go to the IP device web interface.
 - b. Enter your login and password.

c. Click **确定** (Confirm) in the dialog box opened.



d. Click **设备设置** (Device settings).

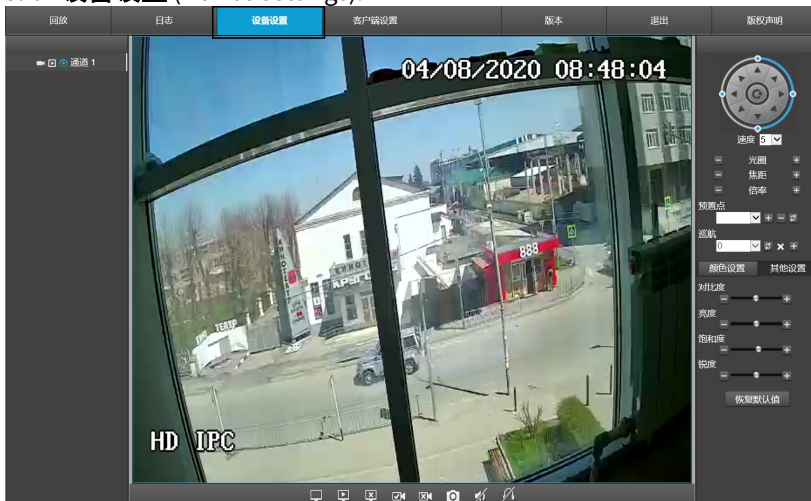

e. Select **Network** in the dialog box.

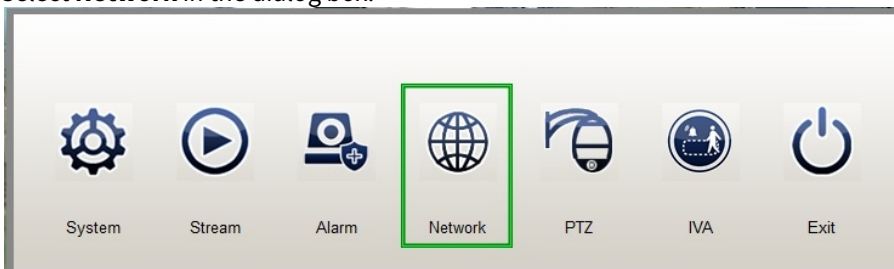

f. In the **Network Management** window, click **GB28181**.

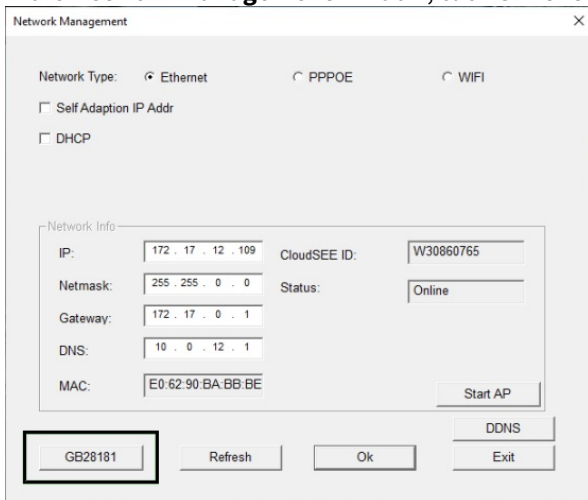

g. The **GB28181** window opens.

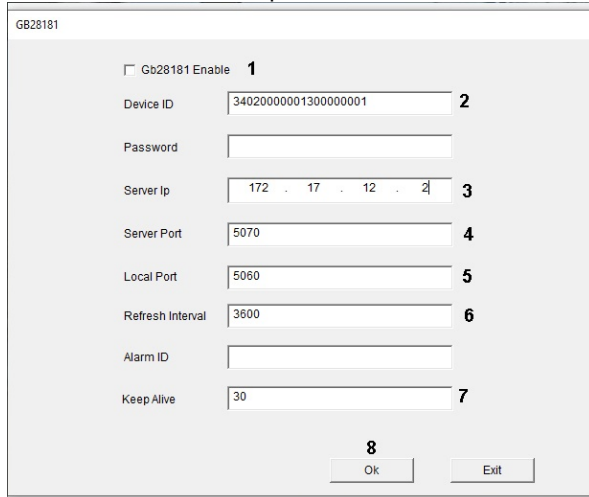

- h. Set the **Gb28181 Enable** checkbox checked (1).
- i. In the **Device ID** field, enter the device identification number as described in [Connecting cameras via the GB/T28181 protocol](#) (2). Example on the picture shows Device ID **3402000001300000001**.
- j. In the **Server Ip** field, enter the Axxon Next server IP-address (3). The example shows IP **179.17.12.2**
- k. In the **Server Port** field, enter Axxon Next server port number assigned for receiving messages from the IP device (4) The example shows port **5070**.
- l. In the **Local Port** field, enter the IP device SIP port number (5).
- m. In the **Refresh Interval** field, enter the device discovery period in seconds (6). The value shall not be less than 600.
- n. In the **Keep Alive** field, enter the period in seconds for sending messages confirming the device activity (7).
- o. Click the **Ok** button (8).

2. In Axxon Next:

- a. Example value for the **IP address** field: **3402000001300000001@3402000001300000002-10.0.40.246/179.17.12.2**
The Server ID 3402000001300000002 is not set on the Jovision device, so any Server ID can be chosen as per the conditions set in [Connecting cameras via the GB/T28181 protocol](#).
- b. Set **Port** to **5070**.

Bosch

Configure a Bosch camera for operation via GB/T28181 standard as follows:

- 1. Perform the following settings of the IP-device:
 - a. Go to the IP device web interface.
 - b. Go to **Configuration - General - GB/T 28181**.

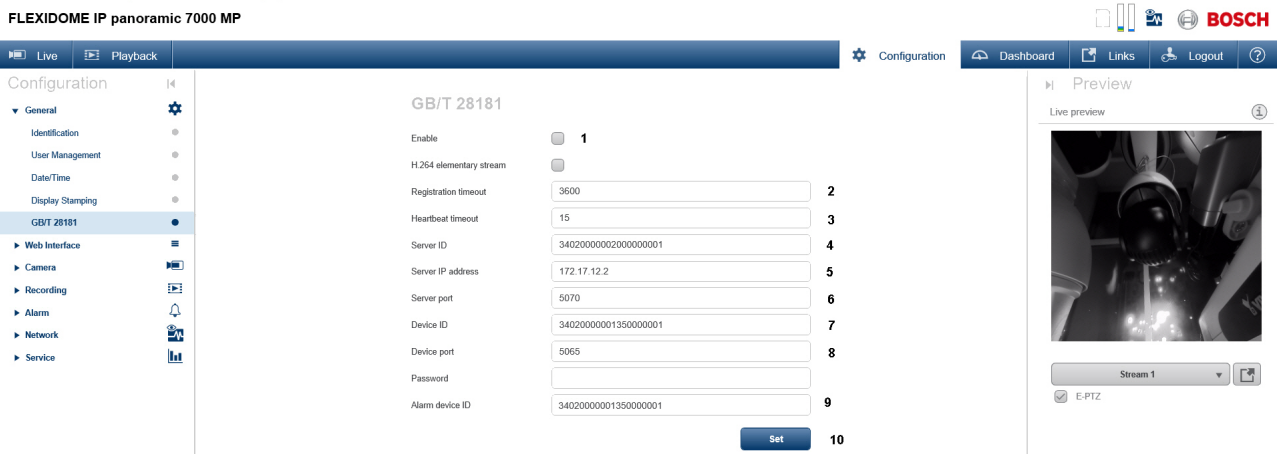

- c. Set the **Enable** checkbox checked (1).
- d. In the **Registration timeout** field, enter the device discovery period in seconds (2). The value shall not be less than 600.

- e. In the **Heartbeat timeout** field, enter the period in seconds for sending messages confirming the device activity (3).
- f. In the **Server ID** field, enter the Axxon Next server identification number (4). The example shows 340200000200000001.
- g. In the **Server IP address** field, enter the Axxon Next server IP-address (5). The example shows 172.17.12.2
- h. In the **Server port** field, enter Axxon Next server port number assigned for receiving messages from the IP device (6). The example shows port 5070.
- i. In the **Device ID** field, enter the device identification number as described in [Connecting cameras via the GB/T28181 protocol](#) (7). Example on the picture shows Device ID 340200000135000001.
- j. In the **Device port** field, enter the IP device SIP port number (8).
- k. In the **Alarm device ID** field, enter the channel identification number (9). The same value as **Device ID** may be used.
- l. Click the **Set** button (10).

2. In Axxon Next:

- a. Example value for the **IP address** field: 340200000135000001@340200000200000001-10.0.40.246/172.17.12.2
- b. Set **Port** to 5070.

Huawei

Configure a Huawei camera for operation via GB/T28181 standard as follows:

1. Perform the following settings of the IP-device:

- a. Go to the IP device web interface.
- b. Go to **Settings - Platform connections - Second Protocol Parameters - T28181**.

The screenshot shows the 'Settings' page of a Huawei IPC. The 'Network' tab is selected, and the 'Second Protocol Parameters' section is expanded to show 'GB/T 28181' configuration. The 'Keep-alive Number' is set to 12. The 'GB/T 28181' section includes fields for Platform IP (10.2.2.107), Port number (5070), Device ID (340200000111000001), Server code (340200000200000001), Login name (340200000111000001), and @ symbol (3402000000). On the right, there are fields for Registration validity (3600), Heartbeat cycle (60), Max number of timeouts (3), Stream index (Secondary 1), and Channel ID (340200000132000000). There are also fields for Alarm input and output IDs. A 'Save' button is at the bottom of the configuration area.

- c. Set the **GB/T 28181** checkbox checked (1).
- d. In the **Platform Ip** field, enter the Axxon Next server IP-address (2). The example shows 10.2.2.107
- e. In the **Port number** field, enter Axxon Next server port number assigned for receiving messages from the IP device (3). The example shows port 5070.
- f. In the **Device ID** field, enter the device identification number as described in [Connecting cameras via the GB/T28181 protocol](#) (4). Example on the picture shows Device ID 340200000111000001.
- g. In the **Server code** field, enter the Axxon Next server identification number (5). The example shows Server ID 340200000200000001.
- h. In the **@** field, enter the first 10 digits of the address according to GB/T-2260-2007 (6).
- i. In the **Registration validity (s)** field, enter the devise discovery period in seconds (7). The value shall not be less than 600.
- j. In the **Heartbeat cycle (s)** field, enter the period in seconds for sending messages confirming the device activity (8).
- k. In the **Max number of timeouts** field, enter the maximum number of Heartbeat message omissions after which the device connection is considered lost (9).
- l. Select the video stream from the **Stream index** drop-down list (10).
- m. In the **Channel ID** field, enter the channel identification number in the same format as Device ID and Server ID (11).
- n. Click the **Save** button (12).

2. In Axxon Next:

- a. Example value for the **IP address** field: 340200000111000001@340200000200000001-10.2.2.107
- b. Set **Port** to 5070.

Hikvision

The Hikvision cameras may support several GB/T28181 standard versions: GB/T28181-2011 and/or GB/ T28181-2016. Examples of configuration for these versions are given below.

Setup video streams as follows before you configure the GB/T28181 standard on the IP device:

1. Go to **配置 - 视音频 - 视频** (Settings - Video and Audio - Video).
2. Configure the main stream:
 - a. From the **码流类型** (Stream type) drop-down list, select **主码流 (定时)** (Main stream) (1).

The screenshot shows the '配置' (Configuration) page for video settings. The '码流类型' (Stream type) is set to '主码流 (定时)' (1). The '分辨率' (Resolution) is set to '2560*1920' (2). The '视频编码' (Codec) is set to 'H.265' (3). Other settings include '视频类型' (Video type) as '视频流', '码率类型' (Bitrate type) as '变码率', '图像质量' (Image quality) as '中', '视频帧率' (Video frame rate) as '20' fps, '码率上限' (Bitrate limit) as '2048' Kbps, 'Smart265' as '关闭', '编码复杂度' (Encoding complexity) as '中', '帧间隔' (Frame interval) as '50', and 'SVC' as '关闭'. A '码流平滑' (Stream smoothing) slider is set to '50' [清晰<->平滑]. A '保存' (Save) button is at the bottom.

- b. From the **分辨率** (Resolution) drop-down list, select the main stream resolution (2).
- c. From the **视频编码** (Codec) drop-down list, select the main stream codec (3).

3. Configure the second stream:

- a. From the **码流类型** (Stream type) drop-down list, select **子码流** (Second stream) (1).

The screenshot shows the '配置' (Configuration) page for the second video stream. The '码流类型' (Stream type) is set to '子码流' (1). The '分辨率' (Resolution) is set to '704*576' (2). The '视频编码' (Codec) is set to 'MJPEG' (3). Other settings include '视频类型' (Video type) as '视频流', '码率类型' (Bitrate type) as '变码率', '图像质量' (Image quality) as '中', '视频帧率' (Video frame rate) as '20' fps, '码率上限' (Bitrate limit) as '4096' Kbps, 'Smart265' as '关闭', '编码复杂度' (Encoding complexity) as '中', '帧间隔' (Frame interval) as '50', and 'SVC' as '关闭'. A '码流平滑' (Stream smoothing) slider is set to '50' [清晰<->平滑]. A '保存' (Save) button is at the bottom.

- b. From the **分辨率** (Resolution) drop-down list, select the second stream resolution (2).
- c. From the **视频编码** (Codec) drop-down list, select the second stream codec (3).

4. Click **保存** (Save).

GB/T28181-2011

- Go to **配置 - 高级设置 - 平台接入** (Settings - Advanced settings - Platform access).

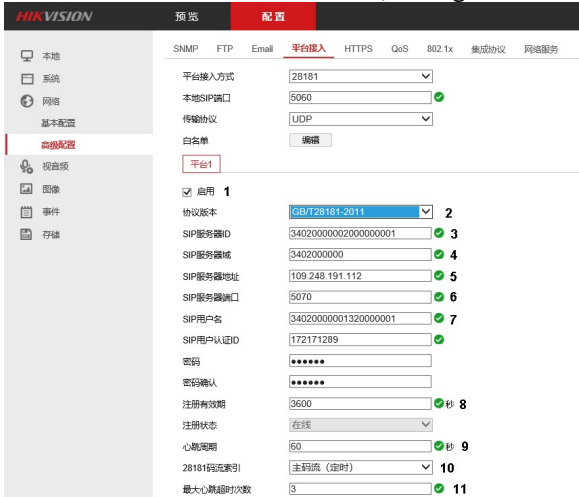

- Set the **启用** (Enable) checkbox (1).
- From the **协议版本** (Protocol version) drop-down list, select **GB/T28181-2011** (2).
- In the **SIP服务器ID** (SIP Server ID) field, enter the Axxon Next Server ID (3). The example shows Server ID **340200000200000001**.
- In the **SIP服务器域** (SIP Server domain) field, enter first 10 digits of the address according to GB/T-2260-2007 (4).
- In the **SIP服务器地址** (SIP Server address) field, enter the Axxon Next server IP-address (5). The example shows IP **109.248.191.112**.
- In the **SIP服务器端口** (SIP Server Port) field, enter the Axxon Next server port number assigned for receiving messages from the IP device (6). The example shows port **5070**.
- In the **SIP用户名** (SIP user name) field, enter the device identification number as described in [Connecting cameras via the GB/T28181 protocol](#) (7). Example on the picture shows Device ID 34020000001320000001.
- In the **注册有效期** (Registration period) field, enter the device discovery period in seconds (8). The value shall not be less than 600.
- In the **心跳周期** (Heartbeat period) field, enter the period in seconds for sending messages confirming the device activity (9).
- From the **28181码流索引** (Video stream) drop-down list, select one of the streams configured earlier (**主码流 (定时)** for Main stream or **子码流** for Second stream) (10).
- In the **最大心跳超时次数** (number of timeouts for Heartbeat messages) field, enter the maximum number of Heartbeat message omissions after which the device connection is considered lost (11).
- Go to the **视频通道编码ID** (Video channel ID) tab at the bottom of the settings page (1).



- Enter the identifiers of all channels of the IP device in the same format as the device identifiers (2). The example shows ID **34020000001320000002**.
- Click the **保存** (Save) button (3).

In Axxon Next:

- Example value for the **IP address** field: **34020000001320000001@340200000200000001-109.248.191.112**

2. Set **Port** to **5070**.

GB/T28181-2016

1. Go to **配置 - 高级设置 - 平台接入** (Settings - Advanced settings - Platform access).

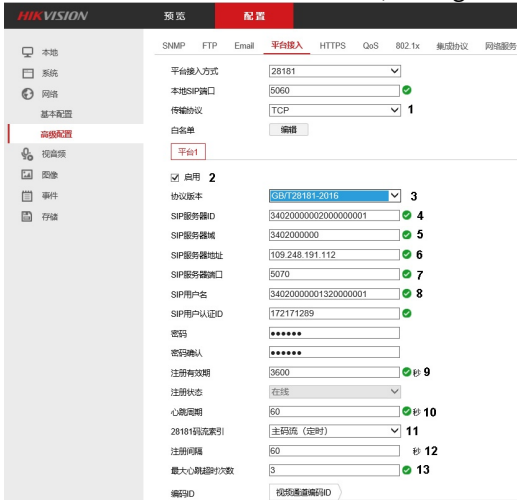

2. From the **传输协议** (Transport protocol) drop-down list, select the transport level protocol to be in use: UDP or TCP **(1)**.
3. Set the **启用** (Enable) checkbox **(2)**.
4. From the **协议版本** (Protocol version) drop-down list, select **GB/T28181-2016** **(3)**.
5. In the **SIP服务器ID** (SIP Server ID) field, enter the Axxon Next Server ID **(4)**. The example shows Server ID **340200000200000001**.
6. In the **SIP服务器域** (SIP Server domain) field, enter first 10 digits of the address according to GB/T-2260-2007 **(5)**.
7. In the **SIP服务器地址** (SIP Server address) field, enter the Axxon Next server IP-address **(6)**. The example shows IP **109.248.191.112**.
8. In the **SIP服务器端口** (SIP Server Port) field, enter the Axxon Next server port number assigned for receiving messages from the IP device **(7)**. The example shows port **5070**.
9. In the **SIP用户名** (SIP user name) field, enter the device identification number as described in [Connecting cameras via the GB/T28181 protocol](#) **(8)**. Example on the picture shows Device ID **340200000132000001**.
10. In the **注册有效期** (Registration period) field, enter the device discovery period in seconds **(9)**. The value shall not be less than 600.
11. In the **心跳周期** (Heartbeat period) field, enter the period in seconds for sending messages confirming the device activity **(10)**.
12. From the **28181码流索引** (Video stream) drop-down list, select one of the streams configured earlier (**主码流 (定时)** for Main stream or **子码流** for Second stream) **(11)**.
13. In the **注册间隔** (Registration interval) field, enter the device discovery interval in seconds **(12)**.
14. In the **最大心跳超时次数** (number of timeouts for Heartbeat messages) field, enter the maximum number of Heartbeat message omissions after which the device connection is considered lost **(13)**.
15. Go to the **视频通道编码ID** (Video channel ID) tab at the bottom of the setings page **(1)**.

编码ID

报警输入编码ID **视频通道编码ID** 语音输出通道编码ID

通道号	视频通道编码ID
1	340200000132000002
2	

保存

3

16. Enter the identifiers of all channels of the IP device in the same format as the device identifiers (2). The example shows ID **34020000001320000002**.
17. Click the **保存** (Save) button (3).

In Axxon Next:

1. Example value for the **IP address** field: **34020000001320000001@340200000200000001-109.248.191.112**
2. Set **Port** to **5070**.

Dahua

Configure a Dahua camera for operation via GB/T28181 standard as follows:

1. Perform the following settings of the IP-device:
 - a. Go to the IP device web interface.
 - b. Go to **网络设置 - 平台接入 - 国标28181** (Network settings - Platform access - GBT28181).

- c. Set the **接入使能** (Enable connection) checkbox (1).
 - d. In the **SIP服务器编号** (SIP server number) enter the Axxon Next Server ID (2). The example shows Server ID **34020000002000000001**.
 - e. In the **SIP服务器IP** (SIP server IP address) enter the Axxon Next server IP address (3). The example shows IP **192.168.88.33**
 - f. In the **设备编号** (Device number) field, enter the device identification number as described in [Connecting cameras via the GB/T28181 protocol](#) (4). Example on the picture shows Device ID **34020000001300000001**.
 - g. In the **本地SIP服务器端口** (Local SIP port) field, enter the IP device SIP port number (5).
 - h. In the **心跳周期** (Heartbeat period) field, enter the period in seconds for sending messages confirming the device activity (6).
 - i. In the **SIP服务器端口** (SIP server port) field, enter the Axxon Next server port assigned for receiving messages from the IP device (7). The example shows port **5060**.
 - j. In the **注册有效期** (Registration period) field, enter the device discovery period in seconds (8). The value shall not be less than 600.
 - k. In the **最大心跳超时次数** (number of timeouts for Heartbeat messages) field, enter the maximum number of Heartbeat message omissions after which the device connection is considered lost (9).
 - l. Click **刷新** (Update).
2. In Axxon Next:
 - a. Example value for the **IP address** field: **34020000001300000001@340200000200000001-192.168.88.33**
 - b. Set **Port** to **5060**.

7.2.3.2.5.4 Generic Drivers (General device, generic)

General Device is a generic driver that supports nearly all devices from a particular camera vendor.

There are 2 types of generic drivers:

1. **General device**. Most configuration of General Device-connected cameras is performed via the web interface of the device. A detailed list of supported features is given on the [Documentation Drivers Pack](#) page.
2. **generic**. When connected via a generic driver, the configuration of the device is read and transferred to *Axxon Next*. After that, you can configure the device from within *Axxon Next*.

Connection via generic drivers is available for the following devices:

	Axis	Bosch	Panasonic	Samsung	Sony	ONVIF
General Device	+	+	+	+	+	
generic	+	+	-	-	-	+

Devices connected via General Device drivers are findable via the IP device discovery wizard. The method for adding them to the system is the same as for ordinary devices (see [Adding and removing IP devices](#)).

IP address	Port	Vendor	
192.168.5.51	0	Bosch	
MAC address		Model	Firmware
00:07:5F:84:91:6F		General Device(1 channel)	auto

Note

Axis devices are affected by a special restriction: if the user name and password for device access do not equal the default values, the number of channels for the device is not discoverable. Therefore, all non-integrated devices whose user name and password for device access do not equal the default values will be shown in search results as 1-channel General Devices.

You should always select a generic driver manually.

If a IP device is not displayed in search results, you can add it manually:

1. In the form for manually adding an IP device, select the device manufacturer from the list (1).

Add device manually: **3** **4**

IP address	Port	Vendor	Username
192.168.0.15	80	Bosch 1	Auto
Device type	Model	Firmware	Password
IP device	General Device(4 channel) 2	auto	****

2. In the **Model** field, select **General Device** or **generic** (2). For Axis and Bosch General devices, select the number of channels on the device.
3. Enter the IP address and port for the device connection (3).
4. Enter the user name and password for connecting to the device (4).
5. Click the  button.

Addition of the device is now complete.

Attention!

If a device, connected via a generic driver, is temporarily not available or it has incorrect connection settings, then it is not added to the configuration.

7.2.3.2.5.5 Connecting and setting up devices with FFmpeg driver

FFmpeg generic driver is applied to receive video and audio data:

1. over RTSP and RTMP protocols (**1 channel device** model),
2. from connected USB devices (**Dshow device (USB camera)** model),
3. from the Server monitor screen (**Desktop capturer** model),
4. from the application window on the Server (**Window capturer** model, without audio).

Receiving video and audio with FFmpeg driver over RTSP and RTMP protocols.

Attention!

FFmpeg currently has the following limitations:

- only one stream is supported;
- video codecs are limited to H.264/H.265, audio to AAC.

To add a device, use the following address format:

```
protocol://[login:password@]IP-address[:port][:/path]
```

IP address	Port	Vendor
rtsp://admin:1111@59.1	80	FFMPEG
Device type	Model	
IP device	1 channel device	

Note

You can set login and password either in the address bar or in corresponding fields when adding the device. If authentication parameters are specified both ways, the address bar has the priority.

Attention!

If you use the address bar method, you must specify the port number. If no port number is specified, default ports are used (554 for RTSP, 1935 for RTMP).

After you add a device, you can set a parameter string for FFmpeg app in the **Additional Options** field. Parameters and their values differ by format, particular device and protocol used.

▼ Other	
Additional options	
Transport protocol	TCP
▼ Alternative view	
Alternative camera 1	Not selected
Alternative camera 2	Not selected

Note

See the full list of parameters for RTSP protocol on the [page](#).

Receiving audio and video from connected USB devices

If a device is added automatically (see [Adding and removing IP devices](#)), separate objects are created for video and audio streams.

If you need to create a single object, add the device manually using the following address format:

```
dshow(<index>)://(<video_device_name>)(:<audio_device_name>)
```

IP address	Port	Vendor
dshow://USB 2.0 HD Camera	80	FFMPEG
Device type	Model	
IP device	Dshow device (USB camera)	

If no index is specified in the address, the value is **0**. Use a non-**zero** index if you use multiple devices with the same name.

For example:

```
dshow://USB 2.0 HD Camera
dshow1://USB 2.0 HD Camera
```

Note

If a video or audio device is not present, it may be not specified in the address.

After you added the device, you have to set up its streams. For archive recording and transferring videos over the network, MJPEG codec is recommended; for detection purposes, use YUV422.

High-quality video stream	0. YUV422/MJPEG
Expected frames per second (fps)	30
Resolution	Auto
Video codec	YUV422
Low-quality video stream	1. YUV422/MJPEG
Bitrate	10000
Expected frames per second (fps)	30
Resolution	Auto
Video codec	MJPEG
Adaptive video stream	Disabled

If required, you can set a parameter string for FFmpeg app in the **Additional Options** field.

Other	
Additional options	
Transport protocol	TCP
Alternative view	
Alternative camera 1	Not selected
Alternative camera 2	Not selected

For example: receive video from a USB camera in YUV420P format, 1280x960 resolution.

```
-pixel_format yuv420p -video_size 1280x960
```

Parameters and their values differ by format and particular device. To list possible parameter values, run the following command from the Windows command line:

```
ffmpeg -list_options true -f dshow -i video="<device name>"
```

Receiving video from the Server monitor with the FFmpeg driver

To receive video from the Server monitor screen, add an object with the following address format:

gdigrab://desktop

IP address	Port	Vendor
gdigrab://desktop	80	FFMPEG
Device type	Model	
IP device	Desktop capturer	

Note

To receive video from remote Clients, you have to use RTSP transmission (see [Receiving video from the remote Client monitor with the FFMpeg driver](#)), or install Axxon Next's Server services on your Client (see [Installation](#)).

By default, videos are transmitted from all Server monitors in MJPEG format. YUV422 format is also available.

High-quality video stream	1. YUV422/MJPEG
Bitrate	10000
Expected frames per second (fps)	30
Resolution	Auto
Video codec	MJPEG
Low-quality video stream	YUV422
	MJPEG

Note

The YUV422 requires more network bandwidth. Take this into account when you select a format.

You can set a parameter string in the **Additional Options** field.

Other	
Additional options	
Transport protocol	TCP
Alternative view	
Alternative camera 1	Not selected
Alternative camera 2	Not selected

Supported parameters	Description
-draw_mouse <int>	Mouse cursor presence. Available range: 0 to 1, default value: 1.
-show_region <int>	Capture area indication. Available range: 0 to 1, default value: 1.
-framerate <video_rate>	FPS value.
-video_size <image_size>	Video image size.
-offset_x <int>	Capture area X offset. Default value is 0.
-offset_y <int>	Capture area Y offset. Default value is 0.

An example parameter string:

```
-draw_mouse 1 -show_region 1 -framerate 25 -video_size 640x480 -offset_x 10 -offset_y 10
```

Receiving video from the remote Client monitor with the FFmpeg driver

Your Server can receive video along with system and microphone audio from a remote Client with the FFmpeg driver over RTSP.

To do it, follow the steps below:

1. On the Server:
 - a. Open the port for receiving data from the remote Client
 - b. Add a **1 channel device** and specify its address in the **IP address** field in the following format:

```
listenrtsp://<Server IP-address>:<Port>/<RTSP-link>
```

IP address	Port	Vendor
listenrtsp://10.0.14.23:5	80	FFMPEG
Device type	Model	
IP device	1 channel device	

Note
RTSP link may be omitted.

2. On the remote Client:
 - a. Download the package of open source FFmpeg libraries from the [official website](#).
 - b. Open the command prompt, and go to the folder containing the ffmpeg.exe file.
 - c. Execute the following command:

```
ffmpeg.exe -f gdigrab -video_size 640x480 -i desktop -c:v <Codec> -f rtsp -muxdelay 0.1 "listenrtsp://<Server IP-address>:<Port>/<RTSP-link>"
```

where

Codec parameter may take mpeg2video, mpeg4, h264 or hevc value;
video_size 640x480 and **-muxdelay 0.1** parameters may be omitted or altered.
 If necessary, you may specify additional parameters in this command.

Supported parameters	Description
-draw_mouse <int>	Mouse cursor presence. Available range: 0 to 1, default value: 1.
-show_region <int>	Capture area indication. Available range: 0 to 1, default value: 1.
-framerate <video_rate>	FPS value.
-video_size <image_size>	Video image size.
-offset_x <int>	Capture area X offset. Default value is 0.
-offset_y <int>	Capture area Y offset. Default value is 0.

After the command execution, remote Client's screen is shared on your display.

Receiving video from the application window on the Server with the FFmpeg driver

To receive video from the application window on the Server, add an object with the following address format:

```
gdirab://"Window title"
```

where "Window title" is the application window header.

Attention!

The address may contain only Latin characters. If the app window header contains some other characters, use any 3rd party utility to change them.

IP address	Port	Vendor
<input axonnext"="" type="text" value="gdirab://"/>	<input type="text" value="80"/>	FFMPEG
Device type	Model	
IP device	Window capturer	

By default, videos are transmitted in MJPEG format. YUV422 and MPEG4 formats are also available.

High-quality video stream	1. YUV422/MJPEG
Bitrate	10000
Expected frames per second (fps)	30
Resolution	Auto
Video codec	MJPEG
Low-quality video stream	YUV422
	MJPEG

Note

The YUV422 requires more network bandwidth. Take this into account when you select a format.

You can set a parameter string in the **Additional Options** field.

Other	
Additional options	
Transport protocol	TCP
Alternative view	
Alternative camera 1	Not selected
Alternative camera 2	Not selected

Supported parameters	Description
-draw_mouse <int>	Mouse cursor presence. Available range: 0 to 1, default value: 1.
-show_region <int>	Capture area indication. Available range: 0 to 1, default value: 1.
-framerate <video_rate>	FPS value.
-video_size <image_size>	Video image size.
-offset_x <int>	Capture area X offset. Default value is 0.
-offset_y <int>	Capture area Y offset. Default value is 0.

An example parameter string:

```
-draw_mouse 1 -show_region 1 -framerate 25 -video_size 640x480 -offset_x 10 -offset_y 10
```

7.2.3.2.6 Configuring connection of video cameras with dynamic IP addresses

Axon Next needs a permanent hostname, such as provided by DynDNS or similar dynamic DNS services to work with IP cameras that use DHCP.

Use your permanent DynDNS hostname to access an IP camera with a dynamic IP address.

7.2.3.2.7 Configuring virtual video cameras

The *Axon Next* software package enables you to work with virtual video cameras.

This requires running *Axon Next* in test mode and consists of imitating a stream of video data by playing an available video clip (recording). You can play video recordings using video compression algorithms supported by Axon Next (see [Specifications of the Axon Next Software Package](#)).

Note

Do not use video with B-frames.

To create and configure a virtual video camera, complete the following steps:

1. Run IP Device Discovery Wizard (see [Adding and removing IP devices](#)).
2. In the form for manually adding an IP device, select **AxonSoft** in the **Vendor** drop-down list (1).

IP address	Port	Vendor
0.0.0.0	80	AxonSoft 1
Device type	Model	Firmware
IP device	Virtual 2	1.0.0

3. Select **Virtual** from the models list to emulate a single-stream video camera. Select **Virtual several streams** to emulate a video camera supporting multiple streams (2).



4. Click the  button
5. In the **Folder** field, specify the storage location of the video clip that will be used to imitate a video signal.

High-quality video stream	0. RAW
Compression Rate	1
Frames per second (fps)	25
Resolution	100 x 100
Video Codec	RAW
vstream-virtual/folder	E:/Video
Low-quality video stream	0. RAW
Adaptive video stream	Disabled

Note

The name of the video file and its file path must consist only of Latin characters

Note

Scanning for files in a specified directory is limited to one minute.

- By default, a video will be played back endlessly. To switch to one-shot playback, set **Yes** for the corresponding parameter.

Other	
Play the file once	Yes
Alternative view	
Alternative camera 1	Not selected
Alternative camera 2	Not selected

- Click the **Apply** button.

7.2.3.2.8 Privacy mask settings

You can impose a privacy mask upon video image to hide parts of the scene from viewing:

- live videos;
- recorded videos;
- exported videos and still frames.

To configure privacy masking, do the following:

- Select the **Object Tracker** object and click the  button.

Note

For your convenience, you can click the  button and configure the mask on a still frame / snapshot. To undo, click this button again.

Note

You cannot do it if the  button is depressed (see [Putting a text over the camera window](#)).

- In the FoV, set the nodes of the closed area you want to obscure.

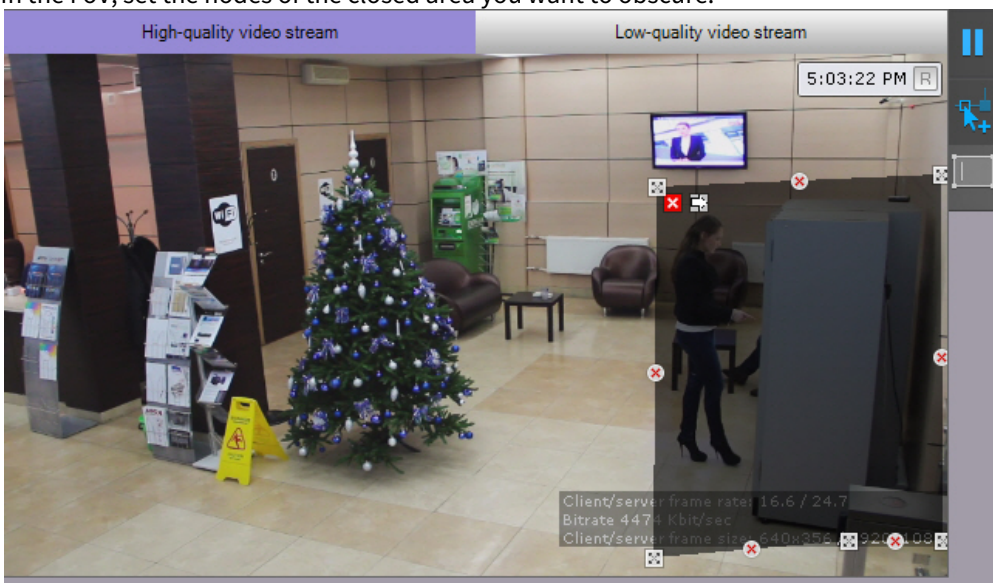

Note

When the area is being constructed, the nodes are connected by a two-color dotted line which outlines the area's borders.

Action	Result
Click in the viewing tile	Creates a new area node
Right-click on a created node	Deletes the area node
Position the cursor on a node and hold down the left mouse button while you move the mouse	Moves the area node
Click the  button.	Deletes the area

3. You can mask the selected area with black matte (by default), or pixelate it. To pixelate the area, do the following:
 - a. Click .
 - b. Select the checkbox.
 - c. Click the **OK** button.
4. You can specify several areas.
5. Click the **Apply** button.

Mask configuration is complete. When you view video from this camera, the selected area will be hidden.



7.2.3.2.9 Putting a text over the camera window

You can superimpose a text over video in the Camera window. This text will be visible to all users in all monitoring modes but will not be present on exported frames and videos.

To put a text over the camera window, do the following:

1. Select a **Camera** object and click .

Note

You cannot do it if the  button is depressed (see [Privacy mask settings](#)).

Note

For your convenience, you can click the  button and configure the mask on a still frame / snapshot. To undo, click this button again.

2. Click any mouse button anywhere in FoV to set two anchor points  of the rectangular area where the text will be displayed. The higher the area, the more the font size.

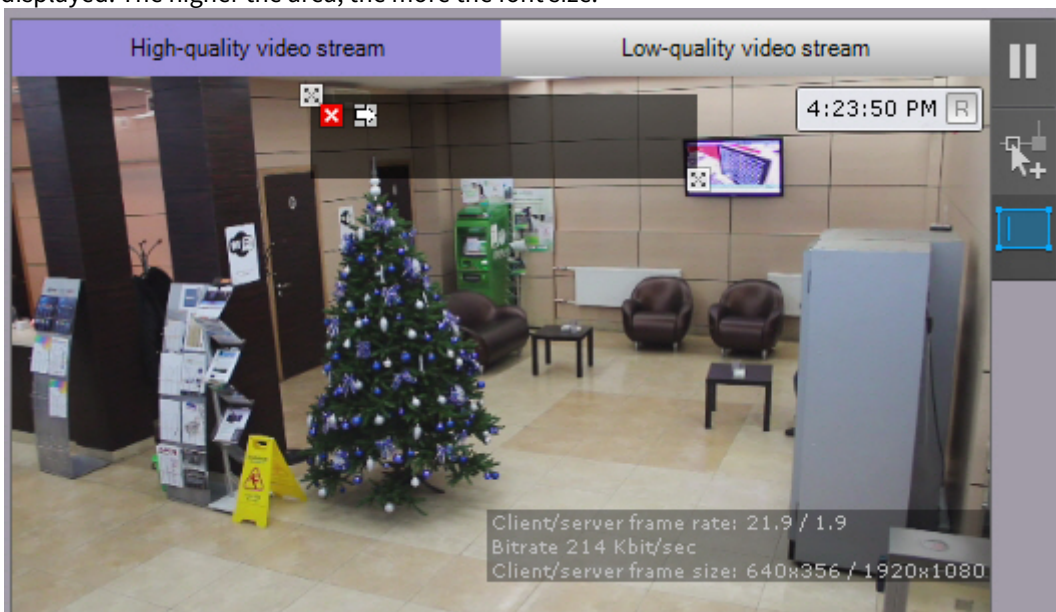

Note

To remove the area, click the  button.

3. Click .
4. Enter the desired text.

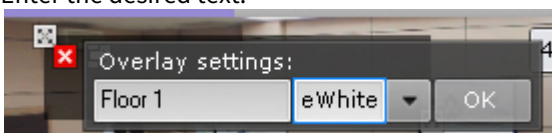

Attention!

The text string has to fit the width of the area. If not, you cannot apply settings. For a longer text, make the area wider.

5. Select a font color from the dropdown list.

6. Click the OK button.
7. If required, you can set multiple text areas in different parts of FoV.
8. Click **Apply**.

Now, the text is superimposed over the video image.

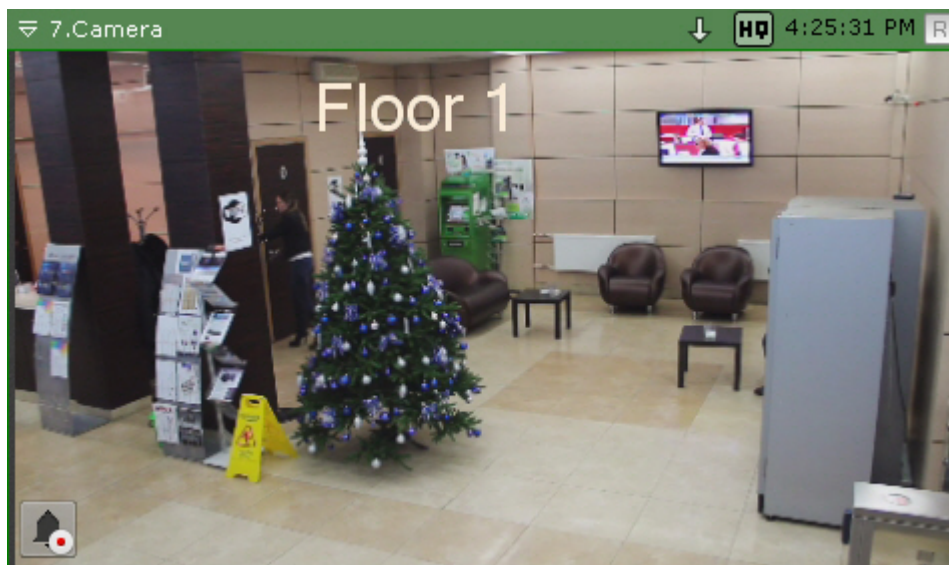

7.2.3.3 The IP Server Object

In the *Axxon Next*VMS, an **IP Server** object relates to:

- video capture card,
- video server,
- control panel,
- DVR, or
- input/output module.

If you configure a video capture card, video server or DVR, each video camera channel corresponds to a **Video camera** object under the **IP Server** parent object.

To configure the IP server parent object, perform the following:

1. Select the IP server object in the objects tree (1).

8.IP server	
Object identification	
2 Enable	Yes
ID	8
3 Name	
Object features	
Address	192.168.22.1
Current firmware	5.51.2.2
Driver version	3.0.0
MAC address	
Manufacturer	Axis
Model	P7216
4 Port	80
Authentication	
Default	Yes
5 Login	root
Password	••••

2. Select **Yes** from the list in the **Enable** field to enable the object (2).
3. Enter the name of the IP server in the Name field (3).
4. Specify the number of the network port (4). The default value is **80**.

Note

The port number is initially set through the IP server's web interface

5. Set the authentication mode (5)

Note

The login and password for connecting to the IP server are set through its Web interface

6. Click the **Apply** button.

The IP server and its video cameras will then be enabled, and the icon indicators for the IP server and video cameras in the objects tree will turn green.

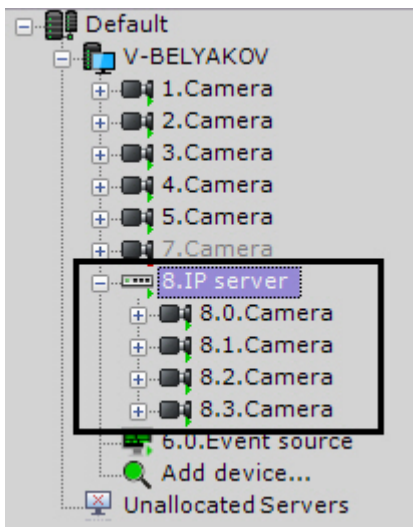

Configuration of IP server channels must be performed separately for each channel (with the help of child objects of **Video camera**).

By default, you cannot delete child Video Camera objects from the IP server. To enable this feature, do as follows:

1. Quit Client.
2. Start a text editor and open the *AxxonNext.exe.config* configuration file located in: <Axxon Next installation folder Axxon Next>\bin
3. Find the line `<add key="AllowIpServerChannelRemove" value="false" />` and change **false** to **true**.
4. Save the changes to the file.

You can now delete camera objects from the IP server.

Attention!

You cannot restore a deleted object. You will need to create the IP server again.

7.2.3.3.1 Configuring Virtual IP Servers

Axxon Next supports working with a virtual IP server.

To create and configure a virtual IP server, perform the following steps:

1. Run IP Device Discovery Wizard (see [Adding and removing IP devices](#)).
2. In the form for manually adding an IP device, select **AxxonSoft** in the **Vendor** drop-down list (1).

IP address 0.0.0.0	Port 80	Vendor AxxonSoft 1
Device type IP device	Model Virtual IP server 2	Firmware 1.0.0

3. Select **Virtual** from the models list to emulate a single-stream video camera. Select **Virtual several streams** to emulate a video camera supporting multiple streams (2).

4. Click the  button

An **IP server** object will be added. It will be used for creating 4 virtual video cameras; location of a video file to be used for signal emulation needs to be specified for each camera (see [Configuring virtual video cameras](#)).

7.2.3.4 The Microphone Object

If a microphone is part of an IP server, then you must specify the video camera to which it will be linked in the settings of the given microphone. When you do this, the **Microphone** object will become a child of the specified **Camera** object.

Attention

When a microphone is reassigned from one camera to another, all previously recorded audio is also transferred; when recorded video on the new camera is played, the transferred audio is played back

Note

This setting is used during synchronized video and audio monitoring of a situation as well as during synchronized video and video recording to the archive (see the section [Audio Monitoring](#))

In all other cases the **Microphone** object will automatically be displayed in the objects tree as a child of the video camera itself.

To configure the **Microphone** object, perform the following:

1. Select the **Microphone** object in the objects tree (1).

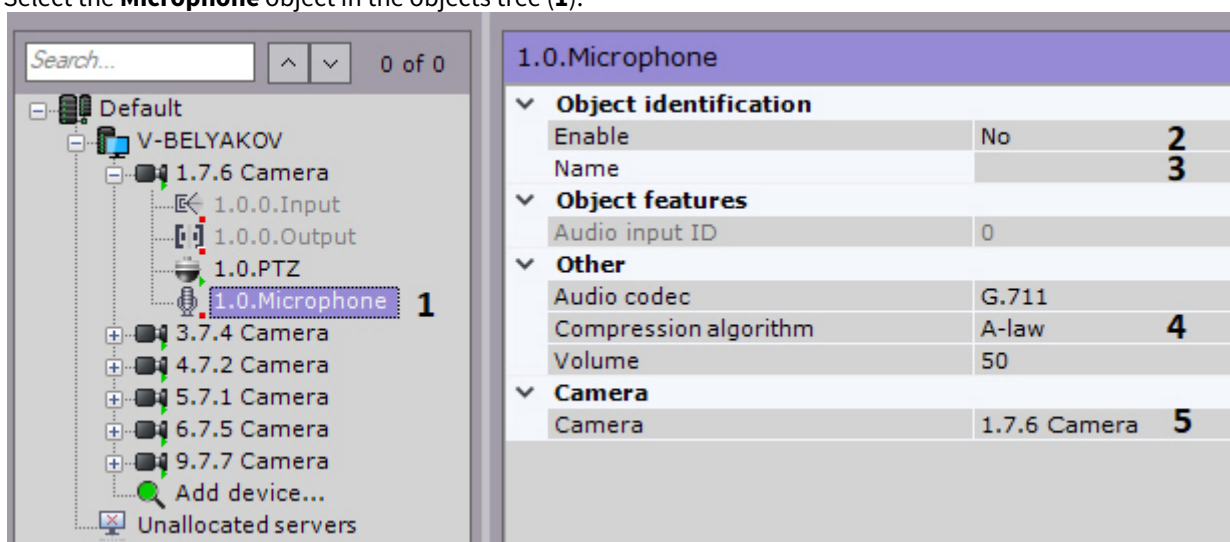

1.0.Microphone		
Object identification		
Enable	No	2
Name		3
Object features		
Audio input ID	0	
Other		
Audio codec	G.711	
Compression algorithm	A-law	4
Volume	50	
Camera		
Camera	1.7.6 Camera	5

2. Enable the microphone by selecting **Yes** in the **Enable** field (2).
3. Enter the name of the microphone in the **Name** field (3).
4. Configure additional microphone parameters (audio codec, bit rate, etc.) in the **Other** group (4) using their descriptions in the interface of the Axxon Next software package or, for more detail, in the official reference documentation of the parent video camera.

- Choose a video camera to associate this microphone with (5). As a result of this operation, the selected camera will become a parent object for the microphone.
- Click the **Apply** button.

The microphone will then be switched to its assigned work mode.

To check the microphone's operation, you must perform the following steps:

- Select the **Sound on/off** check box in the **Summary** group.



- Provide an audio signal to the microphone.
- If the microphone is configured correctly, the audio signal will be transmitted to the server's speakers. The strength of the incoming audio signal will be displayed on the indicator to the right of the **Sound on/off** check box.

Checking microphone operation is now complete.

If a microphone is part of an IP server, the microphone settings allow choosing the video camera of the IP server it will be matched to. When you do this, the microphone object will appear as the child object of the specified camera in the object tree.

7.2.3.5 The PTZ Object

The **PTZ** object is displayed in the device list as the child object of its respective PTZ camera.

To configure a camera's PTZ controls, the following must be true:

- Select the **PTZ** object in the objects tree (1)

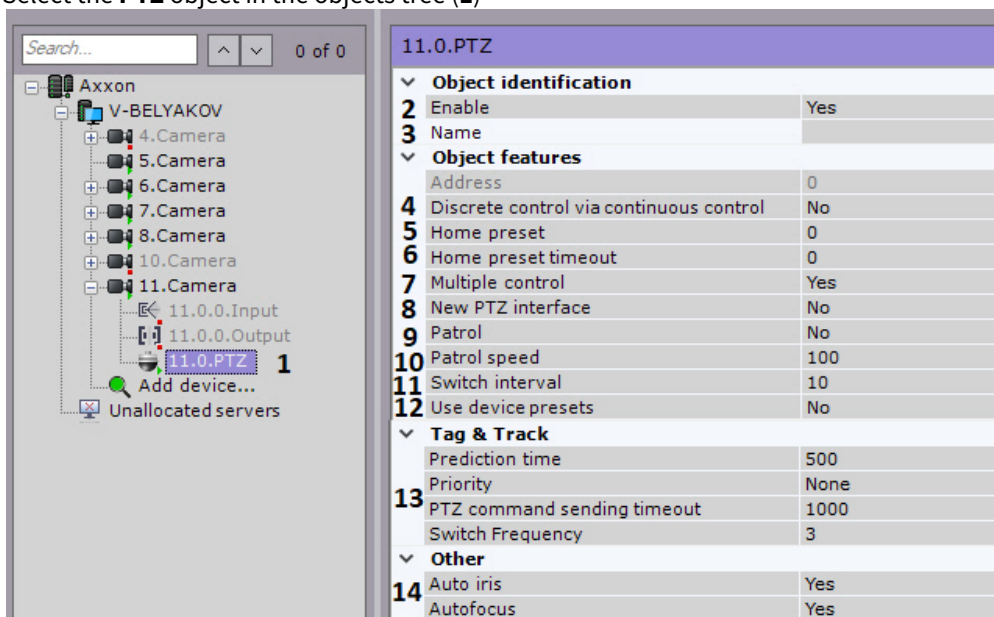

- Enable the PTZ device by selecting **Yes** in the **Enable** field (2).
- Enter the name of the PTZ device (3).
- You can use discrete PTZ control buttons even if a camera does not support discrete mode; to enable this, select **Yes** for the **Discrete PTZ Control via Continuous** parameter. In this case, discrete PTZ control will be emulated via continuous control commands (4).
- Select the **Home preset** by specifying the required identifier (5). The Home preset will be applied automatically after the time period specified in the **Home preset timeout** field (6).
- To simultaneously control a PTZ camera by multiple users with the same priority, select **Yes** in the **Multiple control** List (7). Otherwise, only one user at a time will have a control (see [Controlling a PTZ Camera](#)).
- To use device's existing presets in *Axxon Next*, do the following:
 - If a camera supports the ONVIF protocol, set **Yes** for the **New PTZ Interface** parameter (8). The device's presets will automatically appear in the PTZ control panel.
 - In any other case:

- i. Set **Yes** for the **Use device presets** parameter (**12**).
- ii. Create presets with identical IDs in *Axxon Next* (see [Creating and editing presets](#)).

Attention!

If you have not enabled the Use device presets option, the existing presets can be lost if the following conditions are in place:

1. In *Axxon Next*, the recording presets to the device option enabled (see. P.8).
2. In *Axxon Next*, a preset with the same ID is created (see [Creating and editing presets](#)).

8. Configuring patrol:

- a. Choose the default patrol mode: **Yes** - on, **No** - off (**9**).
If the default patrolling is enabled, it can be stopped in PTZ Control Panel (see [Patrolling](#)). However, after you finish the PTZ control session, patrols will resume automatically.
- b. Set the transition speed from one preset to another in arbitrary units from 0 to 100 (**10**).
- c. Set the interval of time (in seconds) at which the PTZ device will switch between presets while in Patrol mode (**11**).

9. By default, presets are stored on IP cameras. If you want to store presets on Server, select **No** in **Save presets** (**12**).**Note**

This option is available only for devices that support Absolute Positioning.

10. If necessary, configure Tag & Track (**13**, see [Configuring object tracking](#)).
11. Depending on camera, you may find other options in the **Other** group (**14**). To configure them, please refer to the interface help section and tooltips or official documentation.
12. Click the **Apply** button.

The PTZ device will then be switched to its assigned work mode.

To check the functioning of the PTZ device, click the **Test** button. If the PTZ device is configured correctly, it will turn one step and return to its original position.

2.0.Telemetry	
Object identification	
Enable	Yes
ID	2.0
Name	
Object features	
Address	0
Patrol	No
Switch interval	10
Tag & Track	
Priority	None
Switch Frequency	3
Other	
Point-and-click Function	Yes
Switch interval	
Period of time in seconds needed for the PTZ device before it switches to the next preset in the patrol mode. Value should be in range [0, 600000]	
Test	

7.2.3.5.1 Configure HTTP-CGI commands to control Wash&Wiper

With *Axxon Next*, you can control the Wash&Wiper feature in some Axis IP devices (M7016, P7216, Q7404, Q7436) using HTTP-CGI commands.

To set HTTP-CGI commands, do as follows:

1. Create presets for the camera, numbered as follows: 101, 102, 103 and 104 (see [The Presets List](#)).
2. Go to the **PTZ** object and specify commands in the appropriate fields.

Note

The corresponding **Camera** object should have the **Send settings to device** option enabled (see [The Video Camera Object](#)).

Other	
Autofocus	Yes
Control Queue	Yes
Poll Time	30
telemetry_P7210/url101	/axis-cgi/view/param.cgi?action=update
telemetry_P7210/url102	/axis-cgi/view/param.cgi?action=update
telemetry_P7210/url103	/axis-cgi/view/param.cgi?action=update
telemetry_P7210/url104	/axis-cgi/view/param.cgi?action=update
Users in Queue	20
3. Camera	
Camera	10.2.Camera

3. Click the **Apply** button.

When the camera goes to the presets 101-104, this triggers a pre-configured command.

7.2.3.6 The Channel object

For I/O modules or video surveillance control panels (see [CCTV Keyboards](#)), the **Channel** object is displayed as a child object of an IP Server in the object tree (see [The IP Server Object](#)).

To configure the **Channel** object, do as follows:

1. Select the **Channel** object in the objects tree (1).

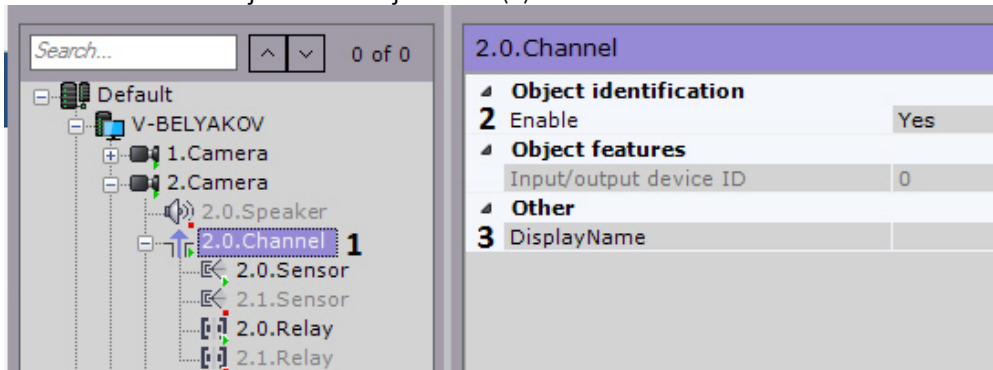

2. Enable the object (2).

Note

When a channel object is enabled / disabled, all **Input** and **Output** child objects are automatically enabled / disabled.

3. Enter the name of the channel (3).
4. Click **Apply**.

7.2.3.7 The Input Object

If a camera has a built-in or pluggable digital input, the **Input** object is displayed as a child object of the **Camera** in the object tree. The total number of **Input** objects for a camera corresponds to its number of pluggable digital inputs.

If a device is defined as an IP Server, an Input will be displayed as a child of a **Channel** object in the object tree (see [The Channel object](#)).

To configure a **Input** object, perform the following:

1. Select the **Input** object in the objects tree (1).

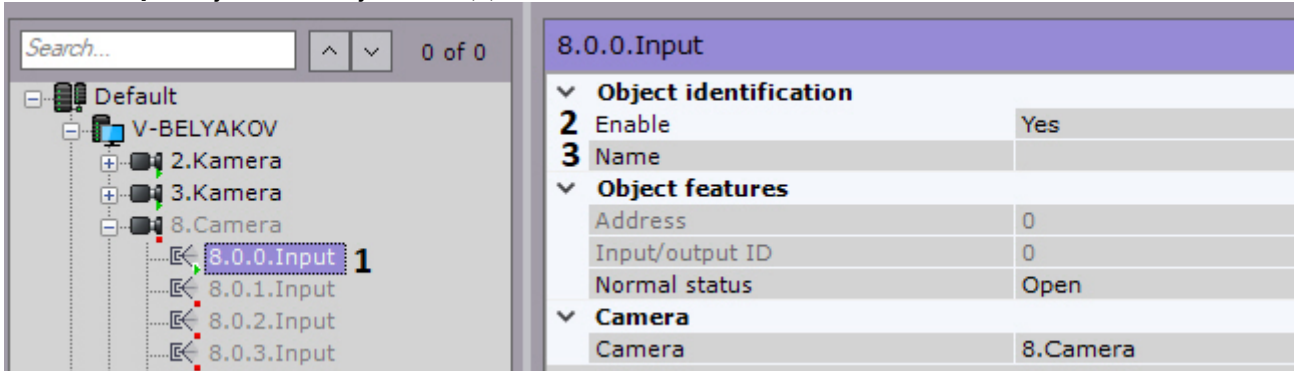

2. Enable the device (2).

Note

If a input is a child of a **Channel** object, then:

- 1) Turning on a input automatically enables its parent **Channel** object.
- 2) Turning off all **Input** and **Output** child objects automatically disables their parent **Channel** object.

3. Enter the name of the Input (3).
4. Set the status to which the Input will be set when no alarm is present.

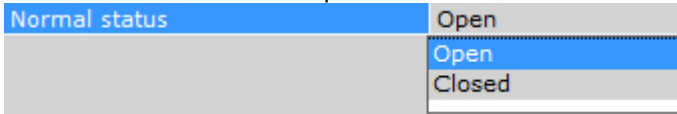

5. Click the **Apply** button.

The Input will then be switched to its assigned work mode.

The current status of the Input is displayed in the **Input information** group.

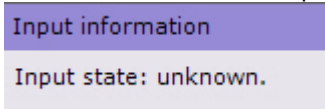

If a Input is part of an IP server, the Input settings allow choosing the video camera of the IP server it will be matched to. When you do this, the Input object will appear as the child object of the specified camera in the object tree.

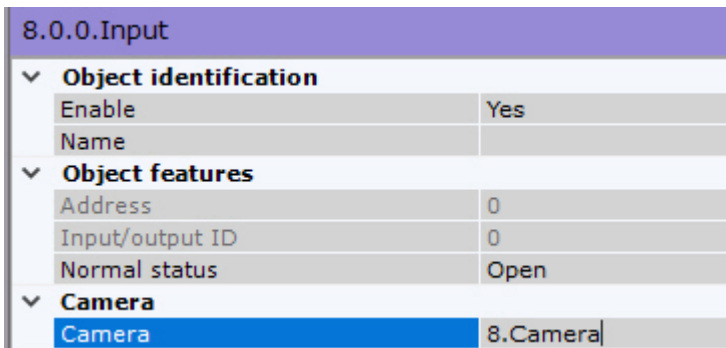

7.2.3.7.1 Configure Virtual Inputs

Switch between virtual IP-device states ([HttpListener](#))

The Axxon Next software package enables you to work with virtual Inputs. This involves triggering a virtual Input and producing a virtual Input event / alarm in the VMS. When triggered, the virtual Input status switches - **Closed / Open**.

To create and configure a virtual Input, complete the following steps:

1. Run IP Device Discovery Wizard (see [Adding and removing IP devices](#)).
2. In the form for manually adding an IP device, select **HttpListener** in the **Vendor** drop-down list (1).

IP address	Port 2	Vendor
0.0.0.0	8080	HttpListener 1
Device type	Model	
IP device	HttpListener device	

3. In the **Port** field, specify the port number that will be used Input status queries (2).



4. Click the  button

The **IP Server** object is automatically created to host 4 virtual Inputs.

Attention!

For a virtual Input to work correctly, please do as follows: use the **Open** circuit.

11.0.0.Input	
▼ Object identification	
Enable	Yes
Name	
▼ Object features	
Address	0
Input/output ID	0
Normal status	Open
▼ Camera	
Camera	

You can configure virtual Inputs in the same way as real ones. Also you can specify the time-out when virtual Inputs reset their status in the **Alarm ExpirationTime** field of the **IP Server** object.

▲ Other	
Alarm Expiration Time	2

Note

It ranges from 0 to 100.

Note

This setting is applied only after you disable and enable the Input again.

7.2.3.8 The Output Object

If a camera has a built-in or pluggable digital output, the **Output** object is displayed as a child object of the **Camera** in the object tree. The total number of **Output** objects for a camera corresponds to its number of pluggable digital outputs.

If a device is defined as an IP Server, a relay will be displayed as a child of a **Channel** object in the object tree (see [The Channel object](#)).

To configure a **Output** object, perform the following:

1. Select a **Output** object in the objects tree.
2. Enable the device (**1**).

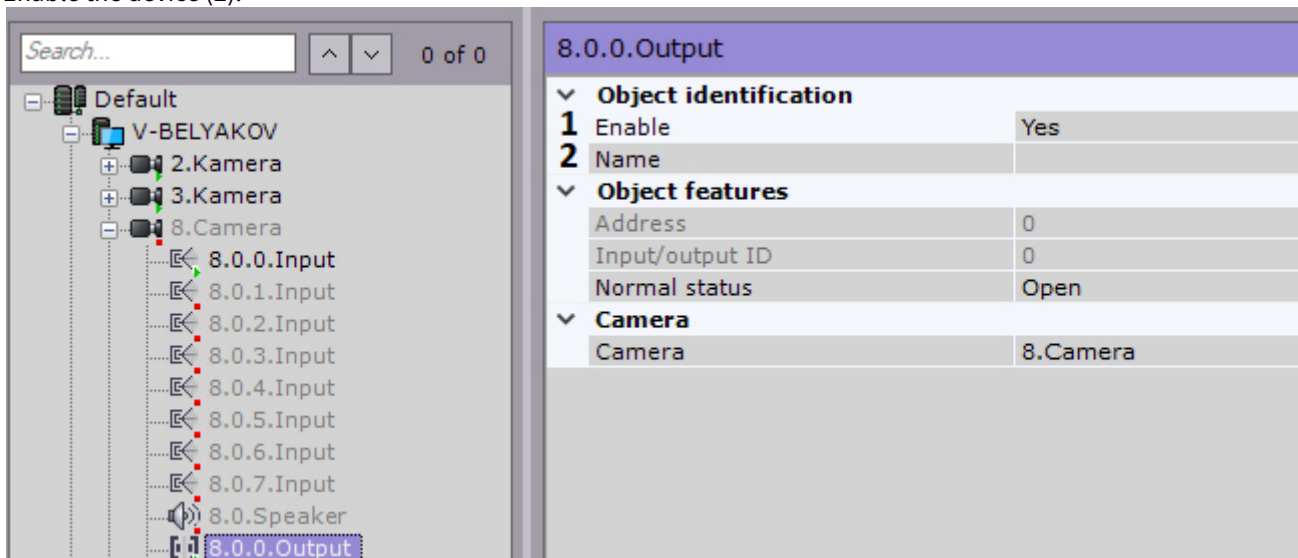

Note

If a output is a child of a **Channel** object, then:

- 1) Turning on a output automatically enables its parent **Channel** object.
- 2) Turning off all **Input** and **Output** child objects automatically disables their parent **Channel** object.

3. Enter the name of the Output (**2**).
4. Set the status to which the Output will be set when no alarm is present.

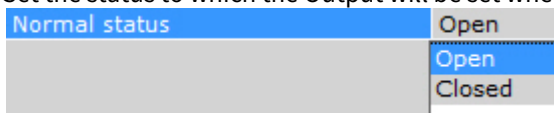

5. Click the **Apply** button.

The Output will then be switched to its assigned work mode.

To check the functioning of the Output, click the **Test** button. If the Output is configured correctly, its status will briefly change.

8.0.0.Output

Object identification	
Enable	Yes
Name	
Object features	
Address	0
Input/output ID	0
Normal status	Open
Camera	
Camera	8.Camera

Enable
Enable/disable output.

Test
Start device test

If a Output is part of an IP server, the sensor settings allow choosing the video camera of the IP server it will be matched to. When you do this, the Output object will appear as the child object of the specified camera in the object tree.

8.0.0.Output

Object identification	
Enable	Yes
Name	
Object features	
Address	0
Input/output ID	0
Normal status	Open
Camera	
Camera	8.Camera

7.2.3.9 The Speaker Object

The **Speaker** object is used for configuration of the sound alert triggered by a macros.

Attention!

Audio notifications cannot be played back via the system speakers on a remote Client. In this case, you are advised to [run an external program on Clients](#).

In Axon Next you can create the following types of **Speaker** objects:

1. **IP speaker device.** Created automatically if there is an audio outlet on an IP device.

Note

One audio outlet on an IP device corresponds to one child **Speaker** of the **Camera** object

2. **System speaker.** Created manually. Sound on the system speaker is played back using the server's sound card.

A **Speaker** object can play audio notification files with the extensions:

1. .wav
2. .mp3
3. .mkv
4. .avi

The following audio notification file encoding formats are supported:

1. G.711
2. G.726
3. PCM

The audio notification file should be stored on the computer corresponding to the **Server** object on the basis of which the **Speaker** object is registered.

7.2.3.9.1 Creating and Configuring an Object

To create a **Speaker** system object, you must perform the following steps:

1. In the list of devices, highlight a **Server** object and click the **Create voice notifier** button (1).

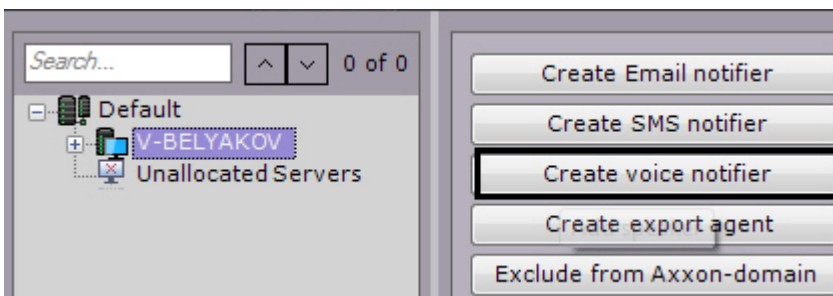

2. In the **Name** field (1), enter the desired name of the **Speaker** object.

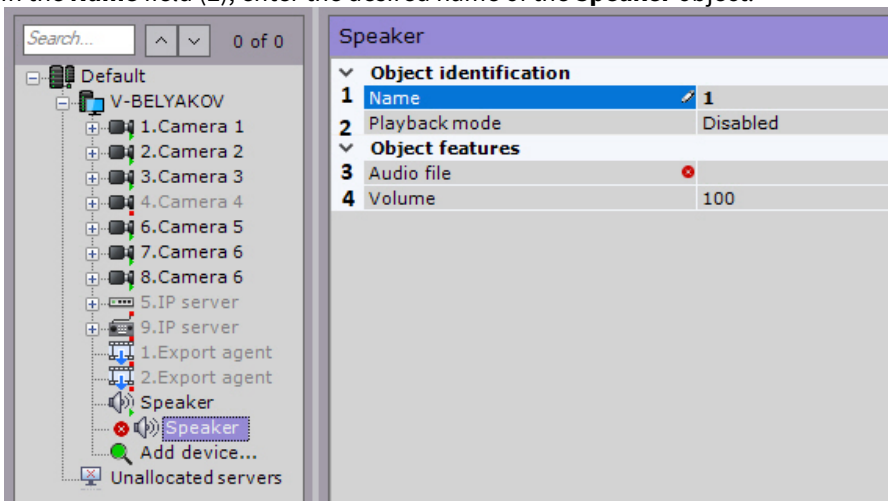

3. Select the speaker mode: disabled, play back on Server, play back on Clients (2).
4. In the **Audio file** field (3), enter the full path to the audio notification file. This parameter is mandatory.
5. In the **Volume** field (4), enter the desired speaker volume level.

Note

By default, IP device speakers are disabled. To enable, for the **Enable** value (1), select **Yes**. When configuring the speaker of an IP device, you can set other parameters as well, such as the compression algorithm for the audio signal sent to the speaker for playback (2). Which speaker parameters you can configure is determined by the protocol for integration of the IP device and the Axxon Next software package

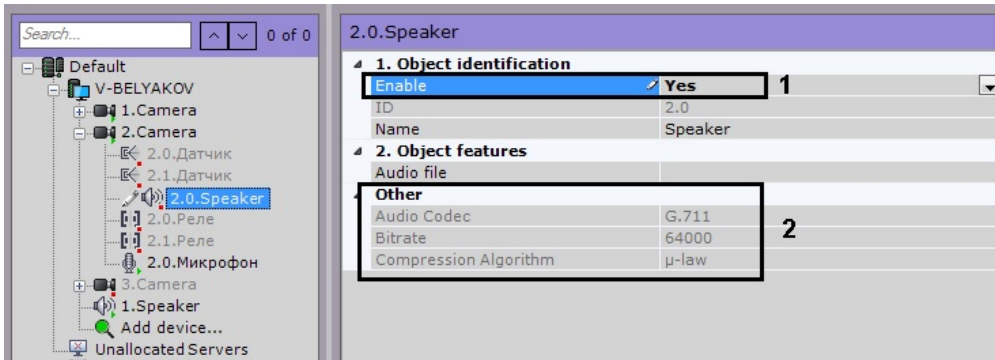

6. Click the **Apply** button.

Creation of the **Speaker** object is complete.

7.2.3.9.2 Configuring a Speaker Object

To configure a **Speaker** object, you must perform the following steps:

1. In the list of devices, highlight the **Speaker** object which needs to be configured (1).

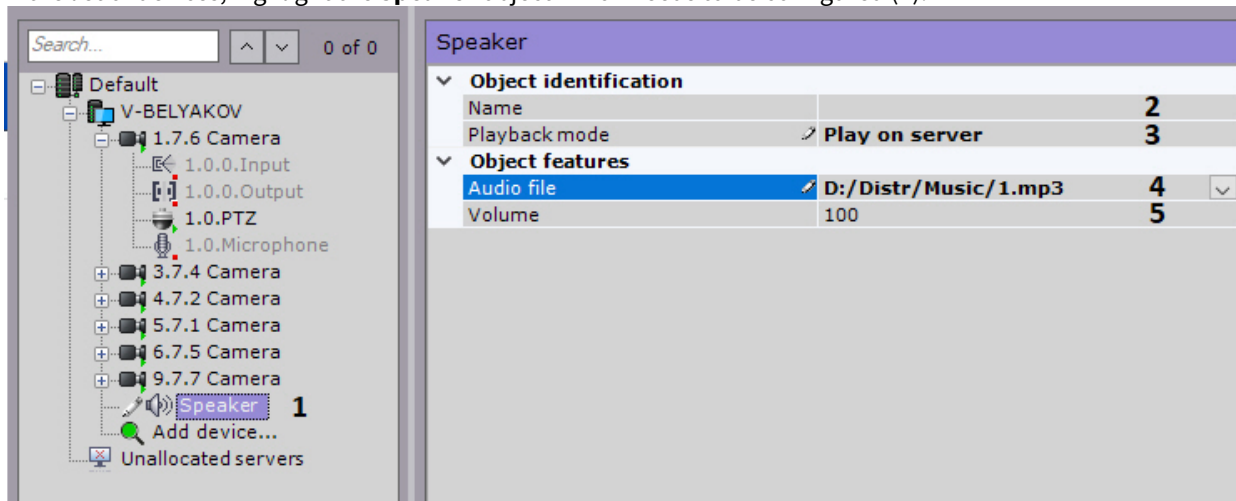

2. Select the speaker mode: disabled, play back on Server, play back on Clients (2).

3. In the **Name** field (3), enter the desired name of the **Speaker** object.

4. In the **Audio file** field (4), enter the full path to the audio notification file.

5. In the **Volume** field (5), enter the desired speaker volume level.

6. To parent an IP device to a speaker:

a. By default, IP device speakers are disabled. To enable, for the **Enable** value (1), select **Yes**.

▼ Object identification		
Enable	No	1
Name		
▼ Object features		
Audio input ID	0	
▼ Other		
Audio codec	G.711	
Compression algorithm	A-law	2
Volume	50	
▼ Camera		
Camera	1.7.6 Camera	3

- b. When configuring the speaker of an IP device, you can set other parameters as well, such as the compression algorithm for the audio signal sent to the speaker for playback **(2)**. Which speaker parameters you can configure is determined by the protocol for integration of the IP device and the Axxon Next software package.
- c. Choose a video camera to associate this speaker with **(3)**. As a result of this operation, the selected camera will become a parent object for the speaker.

7. Click the **Apply** button.

Configuration of the **Speaker** object is now complete.

7.2.3.9.3 Checking Audio Notification

To check audio notification from a **Speaker** object, click the **Test** button.

2.0.Speaker

- ▲ **Object identification**

Enable	Yes
ID	2.0
Name	
- ▲ **Object features**

Audio file	E:/Alarm/Alarm.mp3
------------	--------------------
- ▲ **Other**

Audio Codec	G.711
Bitrate	64000
Compression Algorithm	μ-law
Volume	0

Audio file
Specify the path to the audio file in the field.

When you do this, the audio notification file whose path you indicated in the corresponding field plays back (see the section [Configuring a Speaker Object](#)).

7.2.3.10 The Embedded Storage object

If a camera has on-board storage (SD card), the system will automatically create the corresponding object.

To configure on-board storage, do as follows:

1. Select the required object in the devices list (1).

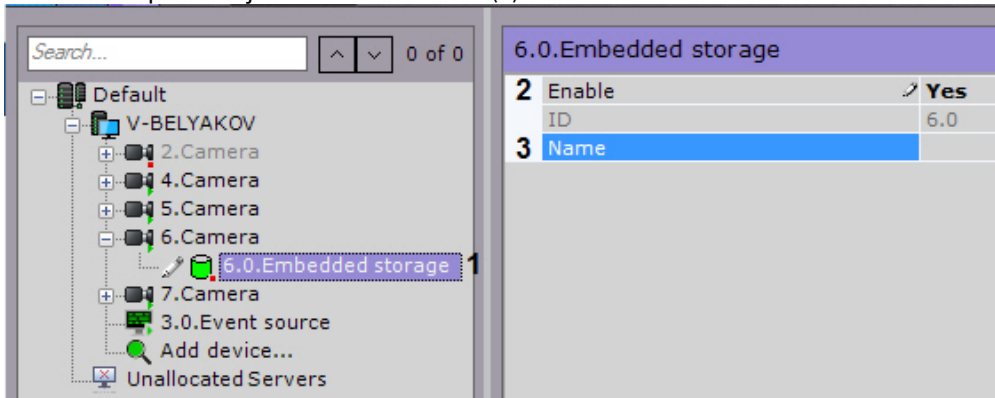

2. Select **Yes** in the **Enable** field to activate the object (2).
3. You can edit the name of the object (3).
4. Click the **Apply** button.

You have configured on-board storage. You can view video from on-board storage (if enabled) and copy it to the archive (see [Configuring data replication](#)).

7.2.4 Particulars of Configuration of Devices

7.2.4.1 AGRG-IO-16/8-WD-DS Sensor-Relay cards

7.2.4.1.1 Connecting AGRG-IO-16/8-WD-DS Sensor-Relay cards

The *AGRG-IO-16/8-WD-DS Sensor-Relay* card is an interface of external sensors and external executive devices (relays) as a part of video surveillance and fire and security alarm systems.

The figure shows the appearance of *AGRG-IO-16/8-WD-DS* card.

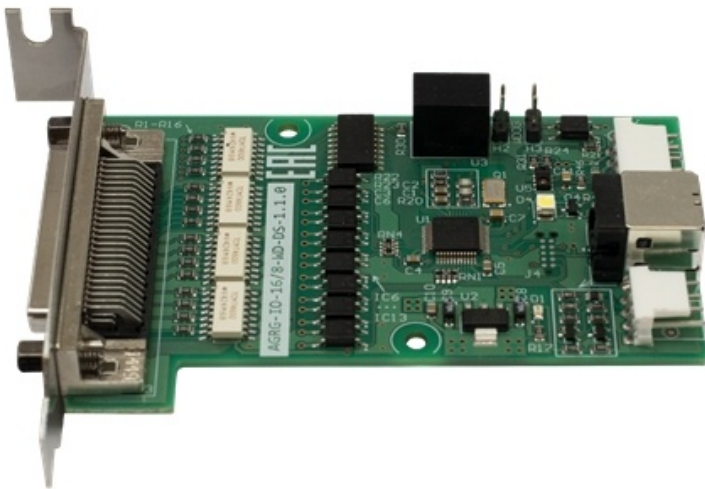

The layout of card connectors:

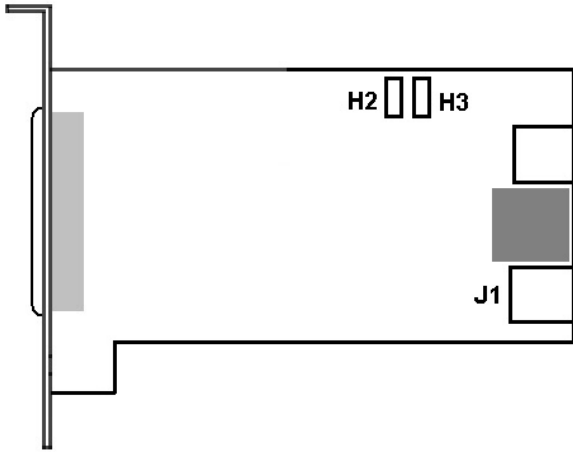

The device is controlled via the USB interface. Electrical and technical specifications of the card are given in the [Electrical and technical specifications of AGRG-IO-16/8-WD-DS devices](#) section.

Connect the *AGRG-IO-16/8-WD-DS* card to the Server as follows:

1. Switch the computer power supply off. Remove the system cover.
2. Install the *AGRG-IO-16/8-WD-DS* card into a vacant motherboard slot and fix it in the casing.
3. Connect the loop (bundled with the distribution kit) to the **J1** connector and to a vacant USB connector on the motherboard of computer.
4. To activate the hardware control of the hang, connect the wires to the **H2 H3** connector.
5. To connect sensors and relays unsolder the connector bundled with the distribution kit.
 - a. The connecting wires from the executive devices are soldered to the contacts marked as "Relay" (see the table below).

Connector	Application	Connector	Application
1	Relay 1 (+)	26	Sensor 5
2	Relay 1	27	Sensor 5
3	Relay 2	28	Sensor 6
4	Relay 2	29	Sensor 6
5	Relay 3	30	Sensor 7
6	Relay 3	31	Sensor 7
7	Relay 4	32	Sensor 8
8	Relay 4	33	Sensor 8
9	Relay 5	34	Sensor 9
10	Relay 5	35	Sensor 9
11	Relay 6	36	Sensor 10
12	Relay 6	37	Sensor 10
13	Relay 7	38	Sensor 11
14	Relay 7	39	Sensor 11
15	Relay 8	40	Sensor 12

Connector	Application	Connector	Application
16	Relay 8	41	Sensor 12

b. The connecting wires from the sensors are soldered to the contacts marked as "Sensor" (see the table below).

Connector	Application	Connector	Application
17	Sensor 1	42	Sensor 13
18	Sensor 1	43	Sensor 13
19	Sensor 2	44	Sensor 14
20	Sensor 2	45	Sensor 14
21	Sensor 3	46	Sensor 15
22	Sensor 3	47	Sensor 15
23	Sensor 4	48	Sensor 16
24	Sensor 4	49	Sensor 16
25	+ 12V (Output)	50	GND (Ground)

6. Fix the unsoldered connector in the casing bundled with the distribution kit.

7. Connect ready-for-use connector to external connector of the card in order to connect sensors and relays to the Server.

The *AGRG-IO-16/8-WD-DS* card is now connected.

7.2.4.1.2 Electrical and technical specifications of AGRG-IO-16/8-WD-DS devices

When connecting the AGRG-IO-16/8-WD-DS sensor-relay cards, the electrical and technical specifications shown in the table below should be considered.

Parameter	Specification
Galvanic isolation on inputs/outputs	3750 V
Inputs	Quantity - 16 Type - current loop Galvanic isolation - Yes Maximum voltage - 60 V Rated voltage - 12 V Maximum current - 60 mA
Outputs	Quantity - 8 Type - open collector Galvanic isolation - Yes Maximum voltage - 300 V Maximum current - 150 mA Minimum pick-up voltage - 1.0 V Minimum pick-up current - 5 mA
Reset Timer (Watchdog)	Customizable
Ping interval of all alarm inputs	100 ms for all contacts. Customizable

Parameter	Specification
PC connection interface	USB 2.0, up to 5 meters
Power supply	500 mA consumption from USB port

7.2.4.1.3 Special features of configuring AGRG-IO-16/8-WD-DS card in Axxon Next

The connected card is automatically detected in the IP Device Discovery Wizard (see [Adding and removing IP devices](#)).

If you add a device manually, enter the serial number of the device in the **IP address** field.

IP address	Port	Vendor
6704474152546672	3600	AGRG
Device type	Model	
IP device	IOUSB-16/8-WD-DS	

To read the serial number, use the manufacturer's [utility](#).

7.2.4.2 Axis IP Devices

7.2.4.2.1 Serial number check

To check serial numbers of Axis IP devices, do the following:

1. Enter a serial number into the appropriate field.

Object features	
Address	192.168.0.12
Port	80
MAC address	
Manufacturer	Axis
Model	P1357
Driver version	3.0.0
Break unused connections	No
Current firmware	
Device serial number	00409CD200C

2. Click **Apply**.
3. The device will be reconnected. Upon reconnection, the entered serial number will be checked against the real one. If numbers do not match, a separate event will be registered in the system Log.

7.2.4.2.2 Bonjour function

For Axis IP devices on which the Bonjour function is supported and enabled, changing the default value of the **Friendly name** parameter is strongly discouraged. If an arbitrary **Friendly name** value is set for an Axis IP device, a search for connected equipment in the Axxon Next software package will give incorrect results for this IP device.

Note

The Friendly name parameter is configured through the Web interface of the IP device: Setup -> System options -> Network -> Bonjour

Note

The default value of the Friendly name parameter is as follows: AXIS <model name> - <mac address>, where <model name> is the model of the Axis IP device and <mac address> is its MAC address (for example, AXIS 214 - 00408C7D2610)

7.2.4.2.3 Video streams

Axxon Next can access the following video streams from Axis IP devices:

1. H.264/MJPEG video
- 2–5. Streams matching the Quality, Balanced, Bandwidth, and Mobile profiles. These profiles are configured via the camera's web interface.

In Axxon Next, the Quality profile corresponds to stream **1. Auto**, Balanced is stream **2. Auto**, Bandwidth is stream **3. Auto**, and Mobile is stream **4. Auto** (see [The Video Camera Object](#)).

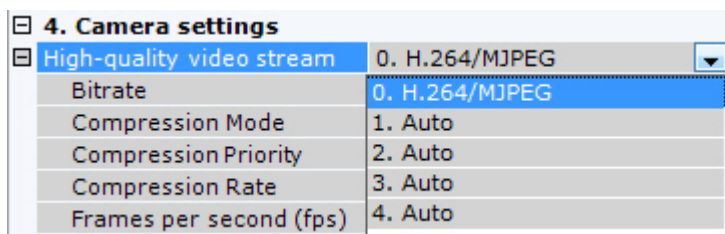

7.2.4.3 CCTV Keyboards

7.2.4.3.1 General Information about CCTV Keyboards

Video surveillance control panels can be connected to *Axxon Next* in two ways:

1. Connecting a panel via the Windows driver as an HID USB device. This method makes the panel immediately available for specifying hotkeys (see [Assigning hot keys](#)).

Attention!

In HID mode, some control panel buttons may not work in *Axxon Next*.

2. Connecting a panel via the *Axxon Next* driver. Using this method, the panel is added to the system similarly to that of IP devices (see [Adding and removing IP devices](#)).

Attention!

To connect a control panel in this way, you need the *Axxon Next* software to be installed in the **Server and Client** configuration. It's not possible to operate a board as a remote client.

The following control panels are supported in the current version of *Axxon Next*:

	Windows driver	<i>Axxon Next</i> driver
Axis T8310 (T8311, T8312, T8313)	+	+
Dahua DH-NKB1000	+	+
PELCO KBD5000	+	+
Videotec DCZ	+	+
Hikvision DS-1005KI	+	+
Hikvision DS-1100KI	-	+
Hikvision DS-1200KI	-	+
Hikvision DS-1600KI	-	+

	Windows driver	Axxon Next driver
UNIVIEW KB-1100	-	+

7.2.4.3.2 Axis T8310 specific configuration features

7.2.4.3.2.1 Setting up on a Server

To make a T8132 keyboard operate with Rev01 hardware, restart the Axxon Next VMS server after you create the IP Server object (see [Shutting down a Server](#), [Starting a Server](#)).

7.2.4.3.2.2 Setting up on a Client

Since the Axxon Next version 4.3.4 and Driver Pack version 3.61, you can use the Axis T8310 control board with remote Clients through the driver embedded into the *Axxon Next* software. The panel is not added to the system as an IP device, and is immediately available for assigning hotkeys.

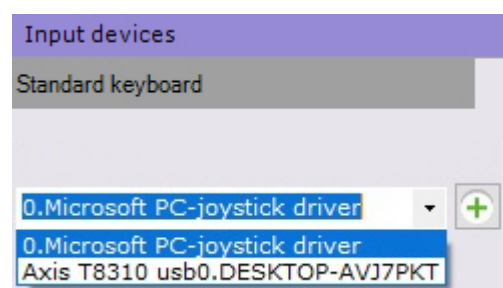

Various models differ in connected [devices](#).

T8310	All devices
T8311	Joystick only
T8311 / T8312	Joystick and keypad
T8311 / T8313	Joystick and jog dial
T8312	Keypad only
T8312 / T8313	Keypad and jog dial
T8313	Jog dial only

7.2.4.3.3 Hikvision DS-1100KI specific configuration features

To work with the DS-1100KI network keyboard in *Axxon Next*, power on the device and do as follows:

1. Switch the keyboard to **Server** mode.
2. Select **Third Platform Software**.
3. Enter the *Axxon Next* Server's IP address and communication port number.
4. You have to use the same port to add the device to the *Axxon Next* VMS.

7.2.4.3.4 UNIVIEW KB-1100 specific configuration features

On page:

- [General description of the UNIVIEW KB-1100 PTZ control device](#)
- [Configuring a remote control before adding it to Axxon Next](#)
- [Configuring UNIVIEW KB-1100 in Axxon Next](#)

7.2.4.3.4.1 General description of the UNIVIEW KB-1100 PTZ control device

A schematic representation of the UNIVIEW KB-1100 PTZ control device is shown in the figure below.

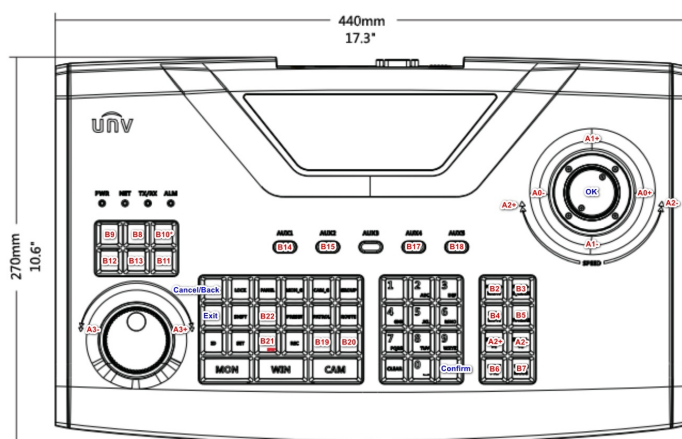

The following physical controls are available on the device:

Joystick is a rotary control moving along three axes:

- Pan axis (panning: left or right deviation).
- Tilt axis (tilt: up or down deviation).
- Zoom axis (scaling: clockwise or counterclockwise deviation).

Acceleration along each of the three axes depends on the degree of deviation from the center. The movement is carried out until release. When released, the control returns to its original position.

Jog-Wheel (not integrated into the *Axxon Next* software package!) is a rotary control rotating only around its axis. When released, the control returns to its original position. In the illustration it is located at the bottom left (outer ring).

Shuttle is a rotary control rotating only around its axis. Allows the intermittent movement in one of two directions. It has no initial position; when released, it remains in place. In the illustration it is located at the bottom left (inner ring).

Button is a push control element that can represent two states. Allows the call of one of two functions (the function for pressing and the function for releasing). When released, it returns to its original position (“not pressed” state).

Of all the push-button controls of the remote control, the following blocks are integrated:

- a block of playback control keys (6 keys on the left: the record button is triggered after pressing a button on the joystick);
- block of keys for control of focus, zoom, aperture and PTZ presets (8 keys);

The following keys to manipulate the device interface are also available (not related to *Axxon Next*):

- Pressing the button on the remote control joystick (OK) (equivalent to pressing the ENTER key).
- Cancel the action / return one step back in the remote control menu (equivalent to pressing the ESC key).
- Numbers / letters are entered from the numeric keyboard, the mode (upper/lower register, digits) is switched by the SHIFT key.

- Moving through the menu items and within the fields is carried out by deviating the remote control vertically / horizontally.

7.2.4.3.4.2 Configuring a remote control before adding it to Axxon Next

Configure the network PTZ 4-dimensional Joystick Remote Control from Uniview (KB-1100) before you create the appropriate object in the Axxon Next VMS. Proceed as follows:

1. Switch on the control device.
2. Enter username and password in the device display. The default credentials are as follows:
 - a. login: admin
 - b. password: 123456
3. Configure the device network configuration. To do this, in the Local Cfg -> Net Cfg menu, set the following settings:
 - a. IP address
 - b. Mask
 - c. Gateway
4. Add the Axxon Next Server to the internal configuration of this CCTV joystick keyboard. To do this, in the Dev Manage -> Manual Cfg -> Add Dev menu, set the following settings:
 - a. ID – enter any number (range: 1-240, the number must not coincide with the ID of the remote control or other already added device).
 - b. name – enter a string (1-8 characters).
 - c. DType – select VM (VideoManagementSystem, i.e. *Axxon Next*).
 - d. LType – select NetWork (the device is integrated for connecting to *Axxon Next* via the network).
 - e. After selecting LType, press the button on the joystick and enter the IP address of the Axxon Next VMS Server and the port used (the default port is 60000).
5. Connect to *the Axxon Next VMS*, added in the step above. To do this, enter the ID specified above in the FindDev -> Dev ID menu or select the found profile in the Dev Manage -> Search Dev menu.
6. If the device is found, information about it will be displayed on the device display.
7. Press on the ID field. This will onboard the remote control in the Axxon Next VMS.

Setting up the UNIVIEW KB-1100 control device is completed.

7.2.4.3.4.3 Configuring UNIVIEW KB-1100 in Axxon Next

Configure the UNIVIEW KB-1100 PTZ joystick control as follows:

1. Go to IP Device Discovery Wizard (see [Adding and removing IP devices](#)).
2. In the **Vendor** list select **Uniview-joystick (1)**.

IP address	Port	Vendor
10.0.11.62 2	60000	Uniview-joystick 1
Device type	3	Model
IP device		KB-1100

3. In the **IP Address** field, enter the IP address of the remote control (**2**).
4. In the **Port** field, enter the port number, as set in step 4 of the remote control settings configuration (**3**).
5. Click the .
6. Enable the newly created **IP Server** and its **Channel** child object.

You have configured the UNIVIEW KB-1100 Joystick Remote Control and CCTV keyboard.

7.2.4.3.5 Hikvision DS-1200KI specific configuration features

On the page:

- [Configuring the Hikvision DS-1200KI control device before adding it to Axxon Next](#)
- [Features of the Hikvision DS-1200KI control device operation in Axxon Next](#)

7.2.4.3.5.1 Configuring the Hikvision DS-1200KI control device before adding it to Axxon Next

Configure the Hikvision DS-1200KI PTZ control device as follows before creating the corresponding object in *Axxon Next*:

1. Set the control device address: **Select System - Network** in the device internal menu, then disable DHCP and set IP address and gateway.



2. Set the *Axxon Next* server IP address and port on the device: Open the device web interface by entering the above set IP address in the web browser, then select **Platform Access - Third-Party Platform**.

Note.

The web interface is only available on https by default, so please use https prefix before the IP address.

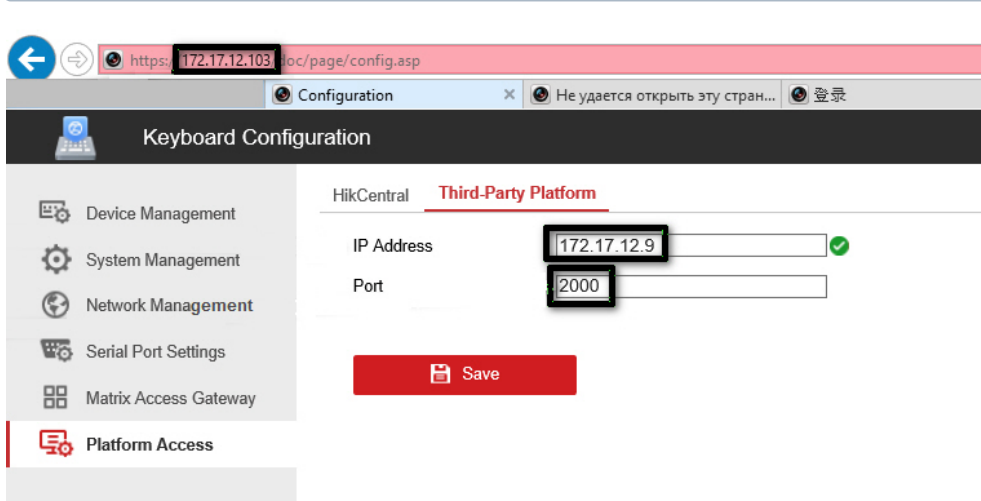

3. Set the **8. Private VMS** mode in the device's internal interface.

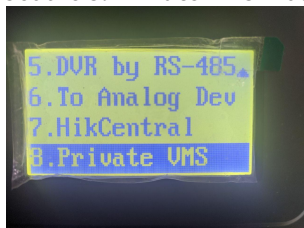

4. Transfer the PTZ control device to operating mode by one of the following actions:
- Select any monitor MON (monitor) [integer in the range 1-9999], any camera CAM (camera) [integer in the range 0-999999]; in this mode all keys will work, including the WIN (subwindow of video wall) and MULT (layout size) keys for the monitor and camera.
 - Select any camera CAM (camera) [integer number in the range 1-999999 (number 0 is available only when setting the monitor)]; the WIN, MULT and CAM-G keys will not work in this mode.
 - Select any monitor MON (monitor) [integer in the range 1-9999] and any group of cameras CAM-G (camera group) [integer in the range 1-999999]; in this mode, only the MULT, OK keys and the rotations of the joystick axes will work.

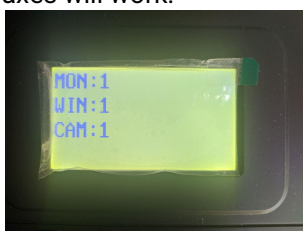

Note.

To select these parameters, enter a number on the device keypad, then press the corresponding key (MON / WIN / CAM / CAM-G).

If the the server IP address and/or port is not accessible from the PTZ control device, the "Connect failed" message will be displayed on the control device screen after pressing the MON / WIN / CAM / CAM-G keys.

The Hikvision DS-1200KI PTZ control device is now preconfigured.

7.2.4.3.5.2 Features of the Hikvision DS-1200KI control device operation in *Axxon Next*

When the MULT, PRESET, PATROL, or PATTERN keys are pressed on the device, the following actions are performed:

- when entering a number in the range 1-99 and pressing MULT for each number, *Axxon Next* receives a message about pressing the corresponding separate key with a number in the range 23-121 (B22-B120);
- when pressing PresetRec for the first time, *Axxon Next* receives a message about pressing key 13 (B12), and the device displays **Record started**;
- after pressing PresetRec for the second time, *Axxon Next* receives a message about pressing key 12 (B11), and **Record ended** appears on the device display;
- when entering a number in the range 1-65535 and pressing PresetRec, *Axxon Next* receives a message about pressing key 22 (B21), and the device displays **PRESET**::;
- when entering a number in the range 1-65535 and pressing Patrol, *Axxon Next* receives a message about pressing key 17 (B16), and the device displays **PATROL**::;
- when entering a number in the range 1-65535 and pressing PatternPlay, *Axxon Next* receives a message about pressing key 18 (B17), and the device displays **PATTERN**::;
- when entering a number in the range 65536-999999 and press any of the PresetRec / Patrol / PatternPlay buttons, nothing happens: such numbers are not processed.

7.2.4.3.6 Dahua DH-NKB1000 specific configuration features

7.2.4.3.6.1 Keyboard operating modes

To work correctly with *Axxon Next* VMS, the keyboard must be recognized by Windows OS as the KEYBOARD 1000 game device.

If the keyboard is recognized as an HID device, hold down the Shift key on the device to toggle its operating mode.

7.2.4.3.6.2 Specific OS settings

If Windows Device Manager recognizes the keyboard as BETTER_USB_HS, the device will not work.

In this case, roll back the device driver. For correct operation, Windows Device Manager has to recognize the keyboard as a HID-compatible game controller.

7.2.4.3.6.3 Specific Axxon Next settings

The Axxon Next VMS may recognize a Dahua DH-NKB1000 keyboard as a Hikvision-joystick DS-1005KI due to their shared device ID.

For correct operation, the keyboard has to be recognized as Dahua DH-NKB1000.

The Pattern button will not work in the Axxon Next VMS.

7.2.4.4 CH VM-Desktop USB multifunction controller

For the controller to work properly in Axxon Next, the controller must be connected before the Axxon Next client is started.

Note

To learn about connecting the device, consult the manufacturer's official documentation.

Controller keys cannot be remapped.

Use of the CH VM-Desktop USB multifunction controller in Axxon Next is described in the corresponding [section](#).

7.2.4.5 Configuring Vivotek Panoramic PTZ

Vivotek Panoramic PTZ is a technology for linking a fisheye camera to a PTZ camera.

This Vivotek technology allows simultaneously maintaining full situational awareness in the field of view of a fisheye camera, while maintaining the ability to carefully monitor a specific area in depth by using a PTZ unit.

Vivotek Panoramic PTZ is supported by the fisheye cameras Vivotek SF8172 and Vivotek SF 8172V and by the PTZ camera Vivotek SD8362E.

To use this technology in Axxon Next:

1. Install and configure the cameras in accordance with the [official Vivotek documentation](#).
2. Add the cameras to an Axxon Next configuration.

Vivotek Panoramic PTZ support in Axxon Next is implemented via the Areazoom (see [Control using Areazoom](#)) and Point&Click functions (see [Control using Point&Click](#)).

7.2.4.6 Video capture cards

Axxon Next supports 3 PCIe and one USB video capture cards:

1. PCIe:
 - a. Yuan SC300Q16.
 - b. [Yuan SC3C0N8](#).
 - c. Yuan WS216.
2. USB: [Yuan PD652](#).

7.2.4.6.1 WS-216 video capture cards

In *Axxon Next*, each WS-216 video capture card corresponds to two devices: manufacturer **ITV**, model **TW5864 PCI** (driver **Yuan, 2**) and manufacturer **CaptureDevice**, model **CaptureDevice** (driver **DShow, 1**).

IP address	Port	Vendor	
dshow8.m-seregin	0	CaptureDevice	
MAC address		Model	Firmware
not defined		CaptureDevice	auto
	1		
IP address	Port	Vendor	
dshow9.m-seregin	0	CaptureDevice	
MAC address		Model	Firmware
not defined		CaptureDevice	auto
	2		
IP address	Port	Vendor	
yuan0.m-seregin	0	ITV	
MAC address		Model	Firmware
not defined		TW5864 PCI	auto
	2		
IP address	Port	Vendor	
yuan1.m-seregin	0	ITV	
MAC address		Model	Firmware
not defined		TW5864 PCI	auto

Note

If you have a WS-216 card added through the Yuan driver, in Windows Server OS you should activate: [Desktop Experience Feature](#)

Cameras connected to *Axxon Next* through the WS-216 card require the following configuration: add **ITV tw5864 PCI** device configuration (2) and select the checkbox **Send settings to device** (see [The Video Camera Object](#)).

Note

Axxon Next does not support receiving uncompressed video from WS-216 video capture cards.

For video cameras that are connected through WS-216 video capture cards, you can choose one of the two codecs for a video stream:

1. H.264 (configurable)
2. H.264 (minimum resolution, non-configurable)

7.2.4.6.2 YUAN PD652 cards

To work with the YUAN PD652 cards in *Axxon Next*, do as follows:

Attention!

Please see the list of supported OS for the YUAN PD652 board on the [official website of the manufacturer](#).

1. Disable the system check for the digital signature of the drivers and install the card [driver](#).
2. Connect the camera to the card.

3. Create an IP device in *Axxon Next*. The search result shows the camera connected through the YUAN PD652 card as follows:

IP address	Port	Vendor
yuan0.r-gzyev	0	ITV
MAC address		Model
not defined		DC1150 USB
		Firmware

4. In the IP device settings, select the TV standard supported by your camera.

High-quality video stream	0. YUV4xx
Expected frames per second (fps)	30
Resolution	720 x 480 x 16
TV standard	NTSC
Video Codec	YUV4xx
Low-quality video stream	0. YUV4xx
Expected frames per second (fps)	30
Resolution	720 x 480 x 16

7.2.4.7 Joysticks

Only joysticks that are detected in Windows as gaming input devices can be used in *Axxon Next* for controlling PTZ cameras. Information on how to view the status for a connected joystick is available in official Microsoft [documentation](#).

Note

We recommend that you calibrate the joystick before you start working with *Axxon Next*.

7.2.4.8 Sony IP Devices

Some Sony models support encoding of the video signal in two formats simultaneously. To use this option you must perform the following steps:

1. Select the **Send settings to camera** checkbox.
2. From the **Dual Encoding** list, select the codec which will take priority when dual encoding.

The screenshot shows the configuration interface for a camera. On the left, under the 'Other' section, the 'Dual Encoding' dropdown is set to 'Yes'. On the right, a settings panel is open, showing the 'Send settings to camera' checkbox checked. Below it, a list of video stream options is visible, including 'High-quality video stream', 'Low-quality video stream', and 'Adaptive video stream'.

7.2.4.9 Setting up Tibbo relay/loop boards

Tibbo relay/loop boards allow monitoring air temperature and humidity on your premises.

To add a board to the configuration, do the following:

1. Go to IP Device Discovery Wizard (see [Adding and removing IP devices](#)).

2. In the **Vendor** list, select **Tibbo (1)**.

IP address 3	Port	Vendor 1
<input type="text" value="0.0.0.0"/>	<input type="text" value="80"/>	<input type="text" value="Tibbo"/>
Device type		Model 2
<input type="text" value="IP device"/>		<input type="text" value="Fine TCP-TB0404"/>
		<input type="text" value="Fine TCP-TB0404"/> <input type="text" value="Fine TCP-TB0808"/> <input type="text" value="Fine TCP-TB1616"/>

3. Select your board from the **Model** list (2).

4. Enter the IP address of the board (3).

5. Click the  button.

The parent **IP Server** object, and **Channel, Input** and child objects under it will be added.

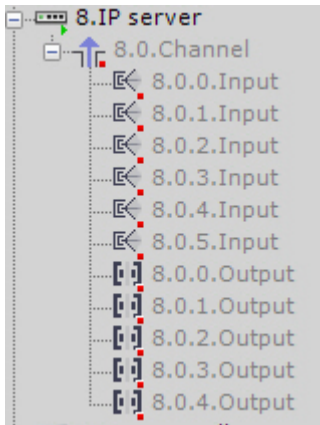

To configure the board, do the following:

1. Select the **IP Server**.

8.IP server	
<input type="checkbox"/> Send settings to device	
Object identification	
Enable	Yes 1
ID	8
Name	
Object features	
Address	192.168.1.40
Break unused connections	No
Current firmware	
Device serial number	
Driver version	3.0.0
Geo location azimuth	0
Geo location latitude	0
Geo location longitude	0
Low group of pictures	No
MAC address	
Manufacturer	Tibbo
Model	Fine TCP-TB0404
Port	80
Synchronous correction of time stamp	No
Authentication	
Default	No 2
Password	
Username	

2. Activate the object (**1**).
3. In the **Authentication** parameter group, set **Default** to **No** (**2**).
4. Select a **Channel** object.
5. Activate the object (**1**).

8.0.Channel	
Object identification	
Enable	Yes 1
Object features	
Input/output device ID	0
Other	
Always report other sensors status	No 4
Maximum humidity	90
Maximum temperature	35
Minimum humidity	10 2
Minimum temperature	15
State check period	500 3
Camera	
Camera	8.IP server

6. Set permissible ranges for temperature (in centigrade) and relative humidity (in per cent)(**2**). If a reading falls out of the range, the corresponding Input (sensor) triggers an alarm.
7. Set the check period in milliseconds (**3**).
8. If you need to report sensors statuses when readings are within the range, set **Yes** for **Always report other sensors status** (**4**). In this case, the following records will appear in the log file in specified intervals of time (see paragraph 7):

```
Special humidity ray#16 changed status to: false ,Sensor value: 16,8 Correct range [15, 58]. Time: ....
Special temperature ray#17 changed status to: false ,Sensor value: 29,8 Correct range [20, 60]. Time: ....
```

9. Click **Apply**.

Now, the board is configured. Current temperature/humidity value will be displayed next to input's icon on the Map (see [Displaying device status](#)).

7.2.5 Configuring object tracking

Axxon Next includes several features for tracking moving objects.

With Tag & Track Pro, an object can be tracked by a PTZ camera under the guidance of panoramic cameras.

Attention!

To use Tag & Track, make sure you have a PTZ camera in *Axxon Next* that supports Absolute Positioning. The devices that support Tag & Track Pro are listed in the [Drivers Pack documentation](#). If a PTZ camera does not meet the requirement, you should add it to the VMS via Onvif.

With Tag & Track Lite, the operator is alerted to the camera in front of which the moving object is most likely to appear next. The camera is predicted based on object trajectory and mapping of cameras to map locations.

For these features to work, you must enable [General information on Scene Analytics](#) on all relevant cameras.

7.2.5.1 Configuring Tag & Track Lite

Configuration of Tag & Track Lite consists of linking video cameras with a site map (see [Configuring cameras in immersion mode](#)).

For stable operation of Tag & Track Lite, you have to set the following on the map (see [Configuring a camera in standard map viewing mode](#)):

- exact position of cameras,
- each camera's FoV,
- FoVs intersections - overlapping areas covered by more than one camera.

FoVs intersection - area, common for FoVs of two cameras - must be no less than triple footprint of the tracked object.

7.2.5.2 Configuring Tag & Track Pro

To configure Tag & Track Pro:

1. Link panoramic cameras to a PTZ camera.
2. Calibrate cameras.
3. Set the PTZ mode.

7.2.5.2.1 Camera requirements for Tag & Track Pro

To follow objects with Tag & Track Pro, mount the cameras at the top of the scene, so that you can track motion on the plane (floor, ground) from above.

You have to point panoramic and PTZ cameras in the same direction.

In addition, panoramic cameras should meet the following requirements: [Video Requirements for Service Video Detection Tools](#)

7.2.5.2.2 Configuring Smooth Motion for PTZ cameras

To smooth panning of a PTZ camera while using Tag & Track Pro, you can configure:

1. The degree of prediction (1). This value should be in the range from 1 to 3000. The higher the value, the smoother is the panning of the camera.

Tag & Track		
1	Prediction time	500
	Priority	None
2	PTZ command sending timeout	1000
	Switch Frequency	3

2. The rate at which coordinates are sent in milliseconds (2). This value should be in the range from 100 to 3000.

7.2.5.2.3 Linking panoramic cameras to a PTZ camera

To link panoramic cameras to a PTZ camera:

1. Go to the **PTZ** object of the relevant camera.
2. In the **Tag & Track** group, in the list (1), select the camera that you want to link to the PTZ camera. Click the **Add button** (2).

Note
To search for a camera, enter its ID, the full or partial name in the **1** box.

Note
You can add only those cameras for which the [Object Tracking](#) was created and activated.

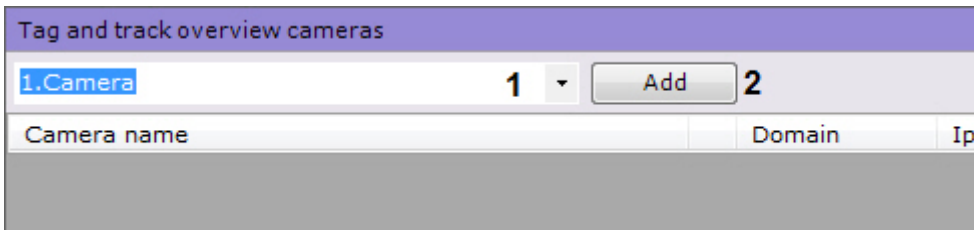

3. Repeat this action for all cameras that you want to link to the PTZ. You can connect any number of panoramic cameras to a PTZ camera.

Note
To remove a camera from the list of panoramic cameras, click the .

4. Click the **Apply** button.

Linking of panoramic cameras to the PTZ camera is now complete.

7.2.5.2.4 Mapping PTZ positions to panoramic field of view (calibration)

For precise tracking of moving objects, you must calibrate PTZ cameras by mapping at least six PTZ positions to points in the field of view of each panoramic camera.

The more positions you map, the more precisely the PTZ camera is able to follow moving objects. It is recommended to map eight or more points.

The calibration procedure is as follows:

1. Focus the PTZ camera on any point.
To change the lens orientation, left-click the frame and, while holding the mouse button, drag the pointer in the relevant direction.

2. Left-click to add a point in the frame of the panoramic camera toward which the PTZ camera is currently oriented.

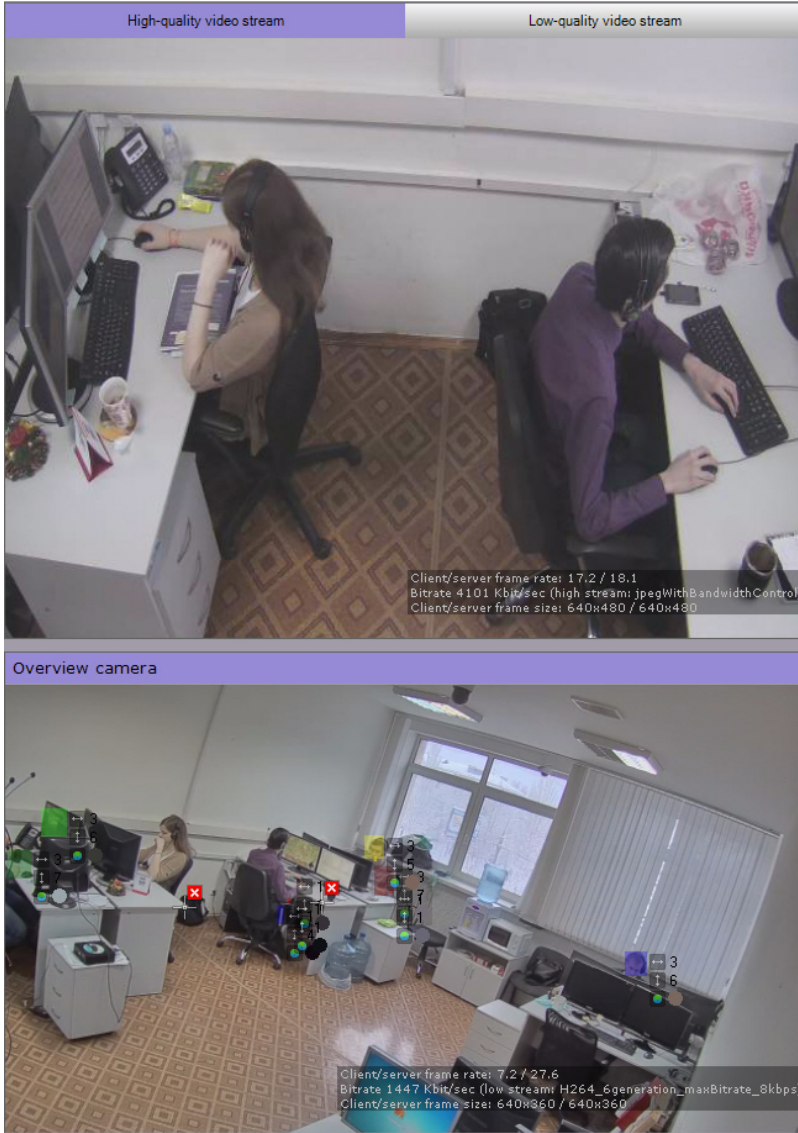

Attention!

Set calibration points on the same plane (floor, ground). Do not set the points on different planes (for example, when some are on the ground while others are on a tree, etc.).

Attention!

The entirety of the moving object must be inside the field of view of the PTZ camera.

3. Repeat this process for at least six points.
4. Repeat the process for all panoramic cameras (click to select a panoramic camera in the list).
5. To save the calibration points, click the **Apply** button.

After setup is complete, we recommend that you perform a calibration check. To do this:

1. Click the  button to the right of the preview for that PTZ camera.
2. Click different points in the camera's field of view. If the PTZ camera is positioned correctly, it needs no calibration.

Note

To delete calibration points, click the  button.

7.2.5.2.5 Setting PTZ mode for Tag & Track Pro

Tag & Track Pro can be used in four PTZ modes:

1. **Manual** – in this mode, a PTZ camera starts tracking an object only after the user selects the object in the viewing tile.
2. **Automatic** – in this mode, a PTZ camera automatically initiates tracking of all active objects. The PTZ camera focus on each object in sequence based on the specified dwell interval.
3. **User priority** – in this mode, automatic mode is used unless the user manually selects an object for tracking. As soon as the user selects an object for tracking, manual mode is activated. When an object is no longer selected or disappears from the PTZ field of view, automatic mode is reactivated.
4. **Manual PTZ control** – in this mode, the operator can take control of the PTZ cameras at any time. If the user does not control the PTZ camera, then the **Automatic** mode is used.

Select a mode in the **Priority** list (1). The dwell time is specified in seconds in the corresponding field (2).

Tag & Track	
1 Frequency	3
2 Priority	None
...	

To save changes, click the **Apply** button.

7.2.6 Receiving Events from External Systems

Axxon Next synchronizes the information from cash registers with the video from cameras pointed at the register area allowing you to monitor the process. In addition, *Axxon Next* operators can receive events from any *Intellect* objects in real time and correlate the received information with the video. The event sources can be e.g.:

- Access control systems
- Security and fire alarm systems
- Perimeter security system

In *Axxon Next*, information from external sources is superimposed on video from a selected camera.

7.2.6.1 Event Source Object

Axxon Next uses the **Event Source** object to get external events. To create the object, make sure that:

1. Run IP Device Discovery Wizard (see [Adding and removing IP devices](#)).
2. In the form for manually adding an IP device, select **Event source** in the **Device type** drop-down list.

IP address	Port	Vendor
0.0.0.0	80	POSLegacy
Device type	Model	Firmware
Event source	POSLegacy Device	auto

3. Click the  button

The **Event Source** object is added to the system.

Note

Once created, the **Event Source** object is enabled by default. To disable, select **No** in the **Enable** field.

7.2.6.2 Configuring POS devices

Axxon Next can obtain data from POS devices and offers the following capabilities:

1. Show titles in live and recorded video.
2. Search titles in recorded video.

7.2.6.2.1 Connecting POS devices

To configure a POS device, do as follows:

1. Select the **Event Source** object.
2. Select a connection type of the POS device (1).

Other	
1	Transport Protocol TCP
2	Port 2555
3	Connection speed 9600
3	Parity Control None
4	Terminal type XML PROTOCOL
	Font Microsoft Sans Serif; 12
	Color <input type="checkbox"/> White
	Ignore Case Yes
	Repeats Processing None
5	DOS to WIN Conversion No
6	Initial UTF-8 Format No
7	Retalix POS-terminal No
	Sample duration 0
	Template file C:/Users/vadim.belyakov/Des

3. Specify the Server connection port (2).
4. To connect via RS-232, select a port, connection speed and parity check (3).
5. Select the type of your POS device (4).
6. Select **Yes** in the **DOS to WIN Conversion** field if the data from the POS device is DOS-encoded (5).
7. If the data is UTF-8 encoded, select **Yes** in the **Initial UTF-8 format** to enable correct display of captions (6).
8. If a Retalix terminal is used, select **Yes** in the corresponding field (7).
9. Click the **Apply** button.

You have successfully connected your POS device.

7.2.6.2.2 Configuring titles view

You can configure the font and where you want the titles displayed on screen. The titles are displayed in a rectangular area superimposed on video.

To configure the titles view, do as follows:

1. In the **Video sources** group, select a camera from the list and click the **+** button to add the camera for titles overlay(1). Titles from any one POS device can be overlaid on video from several cameras.

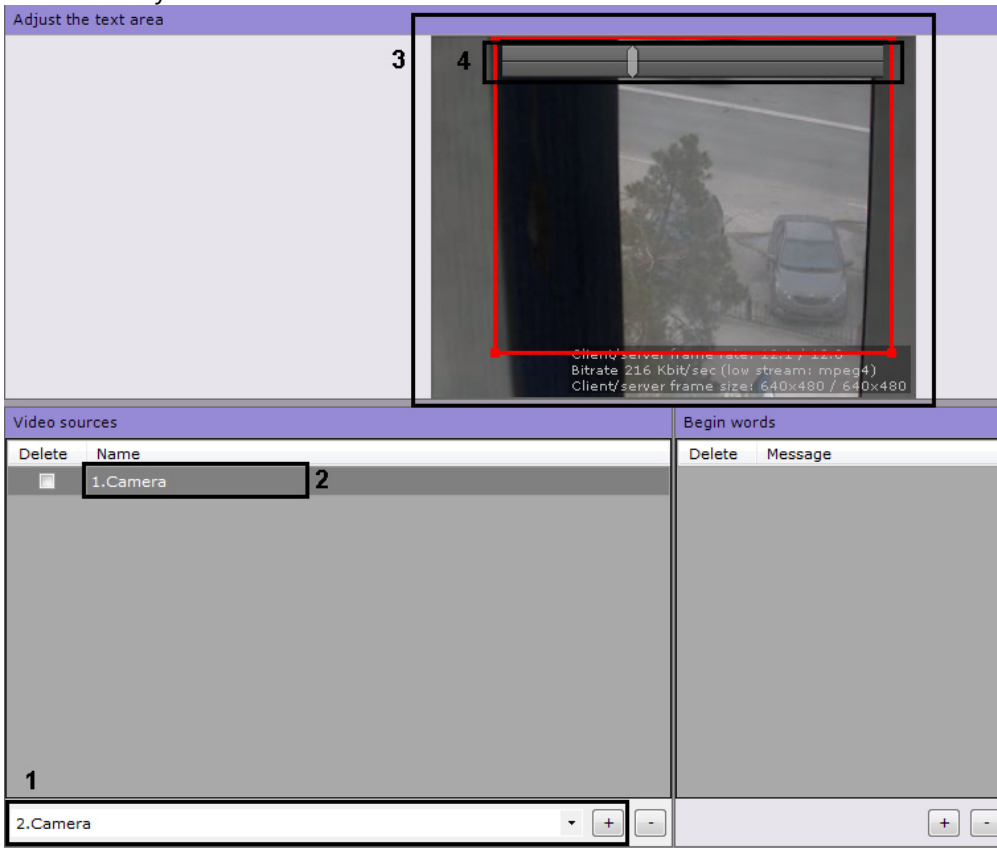

Note

To disable titles overlay for a camera, select the **Delete** checkbox and click the - button.

2. Select a camera in the **Video sources** group (2). The **Adjust the text area** group shows video from the selected camera and the adjustable titles area (3).
3. You can configure the titles area: Resize it by moving the anchor points. Move it with [Drag-and-drop](#).
4. Change transparency with the slider (4). Slide left for more transparency, slide right for less.

5. In the **Font** field, click the  button and specify font settings in a standard Windows box (1).

Other	
Transport Protocol	TCP
Port	2555
Connection speed	9600
Parity Control	None
Terminal type	None
1 Font	Courier New; 12
2 Color	<input type="checkbox"/> White
Ignore Case	Yes
Repeats Processing	None
DOS to WIN Conversion	No
Initial UTF-8 Format	No
Retail POS-terminal	No
3 Background color	<input checked="" type="checkbox"/> Black
4 Bills only	No
5 Display duration	0
6 Erase after end	No
7 Message handling method	PROCESS_LINEARLY
> Serial ports	String[] Array
Template file	
Timeout	100

6. Select font color (2).
 7. Select captions font color in the camera window (3).
 8. If you need to display only the lines contained between start and end markers of the receipt, **Yes** for the **Bills Only** parameter (4).
 9. In the **Display duration** field, set the time in seconds for accumulated text rows on the screen (5). If you set **0**, captions will stay on the screen. New events replace old ones on a continuous basis.

Note

For shops where the checkout is never crowded, we recommend the captions display duration under 10 seconds.

10. If you don't need to display any lines following the end marker of the receipt, set **Yes** for the **Erase Upon Completion** parameter (6).
 11. Select a method of processing incoming data (7):
 a. **PROCESS_LINEARLY** – incoming data is stored in a buffer until the next EOL is received, and only after that is transmitted to Axxon Next.
 b. **PROCESS_EVENT** – each data portion is immediately transferred to Axxon Next.
 c. **PROCESS_JSON** – not available in the current version.
 12. Click the **Apply** button.

You have configured the titles view.

7.2.6.2.3 Configuring receipt beginning / end

The database stores only a full receipt. A receipt starts and ends with the configured phrases. If not configured, receipts contain 2000 lines. In this case, search will not work until the receipt is saved into the database (see [Titles search](#)).

Attention!

It is strongly recommended that you configure this setting for shops with low-intensity events at the checkout. Otherwise, the accumulation of 2000 lines can take a long time.

To configure the beginning and the end of a receipt, do as follows:

1. Populate the **Begin words (1)** group. To add words, click the + button. To remove words, select their **Delete** check boxes and click the - button.

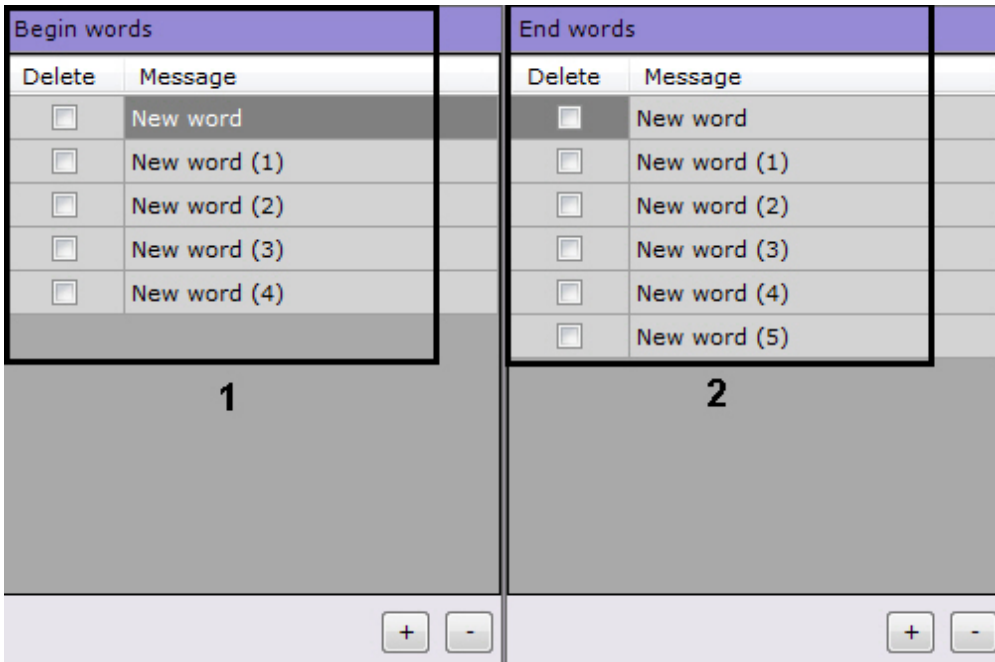

2. Populate the **End words (2)** group in the same manner.

Note
You can add any number of delimiting words. Double click a word to edit it.

3. Delimiting words are case-sensitive by default. To ignore case, select **Yes** in the corresponding field (1).

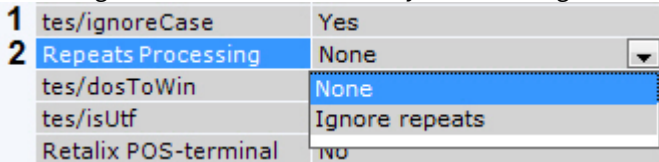

4. Select how to treat repetitions (2).
 - a. Select **Ignore repeats** to skip repeating beginning words before the end words show up. When the end words show up, the next receipt starts with the beginning words.
 - b. Select **None** to skip the end words and delimit receipts by the beginning words only.
5. Click the **Apply** button.

You have configured how receipts are delimited.

7.2.6.2.4 Configuring keywords

Keywords can be highlighted in the titles.

To configure keywords, do as follows:

1. Select any number of keywords in the **Word highlighting** group with the + button. Double click a keyword to edit it.

Word highlighting		1	2	3	4	5
Delete	Message	Color	Change background color	Background color	Case sensitive	Whole string
<input type="checkbox"/>	Beer	Red	<input checked="" type="checkbox"/>	Gray	<input type="checkbox"/>	<input type="checkbox"/>
<input type="checkbox"/>	Vodka	Red	<input checked="" type="checkbox"/>	Gray	<input type="checkbox"/>	<input type="checkbox"/>

Note

To remove words, select their **Delete** check boxes and click the - button.

2. You can also configure these parameters:
 - a. Highlighting color (1). In the appropriate column, click the  button and choose a color.
 - b. If you want to change the color of the background of the titles output in the camera window, select the corresponding check box (2) and select the required color (3) when this word appears.
 - c. Select the **Case sensitive** check if you want (4).
 - d. To highlight the whole line, select the **Whole string** checkbox (5).
3. Click the **Apply** button.

You have configured highlighting for keywords.

7.2.6.2.5 Importing parcers

A special parsing algorithm processes the receipts and adds data to the receipts database. This is an option for advanced settings.

The choice of parcers depends on POS data structure:

1. XML parcer for .txt files
2. POS parcer for .prl files

The XML parser specifies the rules for adding data to the receipts database if you have XML data from a POS terminal. The XML parser also validates the XML data against a schema.

The POS parser specifies the rules for adding data to the receipts database if the data is from a POS terminal is other than XML. The parser depends on the POS terminal data structure.

To import a parcer, do as follows:

1. In the **Template file** (1) field, click the  button.

Other	
Transport Protocol	TCP
Port	2555
Connection speed	9600
Parity Control	None
2 Terminal type	XML PROTOCOL 
Font	Courier New; 12
Color	<input type="checkbox"/> White
Ignore Case	Yes
Repeats Processing	None
DOS to WIN Conversion	No
Initial UTF-8 Format	No
Retalix POS-terminal	No
<TextEventSourceUnit	<input checked="" type="checkbox"/> Black
Bills only	No
Display duration	0
Erase after end	No
> Serial ports	String[] Array
Specify timeout	100
String manipulation	Yes
1 Template file	

You can browse for the required parser.

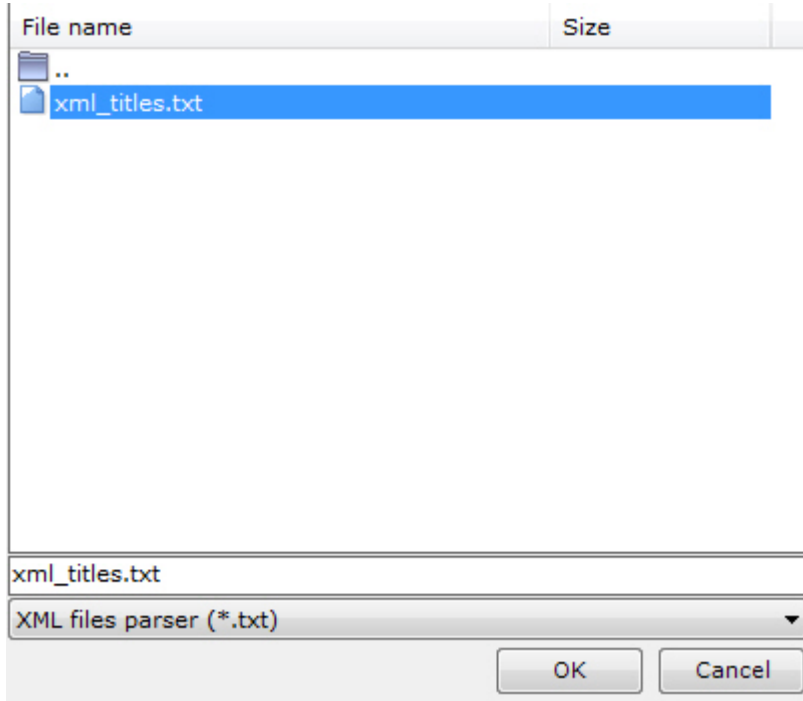

2. Select the type of the parser and the file.
3. If you use an XML parser, select **XML PROTOCOL** in the **Terminal Type** field (2).
4. Click the **Apply** button.

You have imported the parser.

7.2.6.3 Receiving Intellect Events

To be able to receive *Intellect* events, do as follows:

1. On the *Intellect* machine, configure a data transfer module (see [ACFA Intellect - Axxon Next Bridge Settings Guide](#)).
2. In *Axxon Next*, select the **Event Source** object.

Other	
1	Transport Protocol TCP
2	Port 2555
	Connection speed 9600
	Parity Control None
3	Terminal type XML PROTOCOL
	Font Microsoft Sans Serif; 12
	Color <input type="checkbox"/> White
	Ignore Case Yes
	Repeats Processing None
	DOS to WIN Conversion No
	Initial UTF-8 Format No
	Retalix POS-terminal No
	Sample duration 0
4	Template file C:/Users/vadim.belyakov/Des

3. Select **TCP** in the Transport protocol field (1).
4. Specify the connection port to *Intellect* (2).
5. Select **XML PROTOCOL** in the Terminal type field (3).
6. Select a preconfigured parser (4, see [Configuring parser](#)).
7. Configure the data output similar to that of the POS device (see [Configuring titles view](#)).
8. Configure keywords, if necessary (see [Configuring keywords](#)).
9. Click the **Apply** button.

If the setup procedure was done correctly, the events from specified objects will be displayed in the viewing tile on *Intellect* in the same way as POS device captions do (see [Viewing titles from POS terminals](#)).

7.2.6.4 Configuring Receiving Events from CommaxComplexServer

CommaxComplexServer events can be forwarded to the Axxon Next VMS in two formats:

1. In JSON format using the **Event Source** (see [Configuring CommaxComplexServer via Event Source](#)).
2. As events from Virtual Inputs. This creates a virtual IP Server in the VMS (see [Configuring CommaxComplexServer via virtual IP server](#)).

Note

CommaxComplexServer is smart apartment complex management software. It receives input from gates, doors, elevator call buttons etc.

Configure CommaxComplexServer before connecting to Axxon Next.

7.2.6.4.1 Configuring CommaxComplexServer via Event Source

Connect CommaxComplexServer via **Event Source** as follows:

1. Run IP Device Discovery Wizard (see [Adding and removing IP devices](#)).
2. In the field for manually adding an IP device, select **Event Source** in the **Device Type** drop-down list (1).

IP address	Port	Vendor
0.0.0.0	3600	Commax 2
Device type	Model	
Event source 1	ComplexServer	

3. In the **Vendor** list select **Commax** (2).
4. Click the button



The **Event Source** object is added to the system.

5. Select the new object.

Other	
Font	Courier New; 12
Color	<input type="checkbox"/> White
Ignore Case	Yes
Background color	<input checked="" type="checkbox"/> Black
Bills only	No
Display duration	0
Erase after end	No
Port	2555
Serial ports	String[] Array
Transport protocol	TCP

6. Enter the destination port name for CommaxComplexServer events.
7. Click **Apply**.

The CommaxComplexServer connection is now configured.

Note

You can present information as caption (titles) superimposed on video in the Camera window. See POS configuration instructions for that (see [Configuring POS devices](#)).

7.2.6.4.2 Configuring CommaxComplexServer via virtual IP server

Connect to CommaxComplexServer via virtual IP server as follows:

1. Run IP Device Discovery Wizard (see [Adding and removing IP devices](#)).
2. In the field for manually adding an IP device, select **Commax** in the **Vendor** drop-down list (1).

IP address	Port	Vendor
10.0.11.66 3	80	Commax 1
Device type		Model
IP device		generic 2

3. Select **generic** in the **Model** list (2).
4. Enter the IP address of the CommaxComplexServer (3).



5. Click the button.

The parent **IP Server** object and **Channel** and **Input** objects under it are added according to CommaxComplexServer configuration. The names of the **Input** objects in the VMS and CommaxComplexServer are the same.

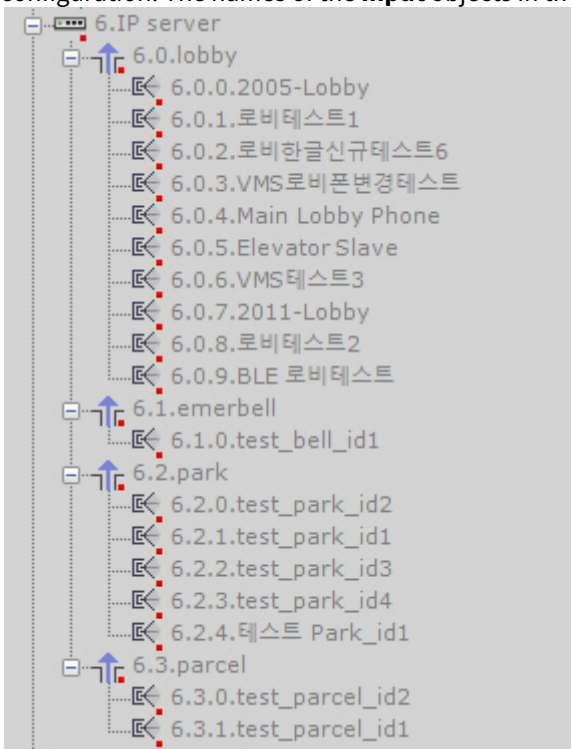

6. Select the **IP Server** object.

7. Enter the destination port name for CommaxComplexServer events.

6.IP server	
Object identification	
Enable	No
Name	6
Name	
Object features	
Address	220. .12
Break unused connections	No
Current firmware	
Device serial number	
Driver version	3.0.0
Geo location azimuth	0
Geo location latitude	0
Geo location longitude	0
Low group of pictures	No
MAC address	
Manufacturer	Commax
Model	generic
Port	80
Synchronous correction of time stamp	No
Authentication	
Default	No
Password	
Username	
Other	
Port	2555

8. Click **Apply**.

The CommaxComplexServer connection is now configured.

7.2.7 Configuring video camera groups

You can manually group video cameras to enable quicker selection of a specific video camera for display.

Video camera groups are configured through the interface using the **Devices** tab (under **Settings**). To configure device groups, you must have the appropriate permissions to configure devices.

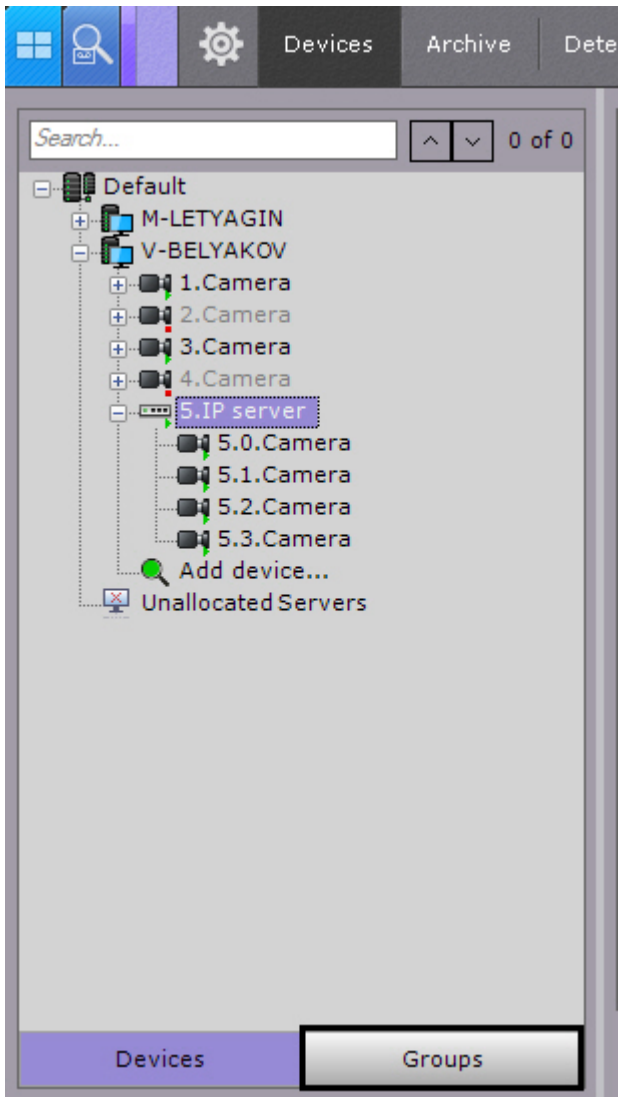

7.2.7.1 Procedure for configuring video camera groups

To configure video camera groups, complete the following steps:

1. Create **Group** objects.
2. Add video cameras created in the system to **Group** objects.
3. Create a system of groups and subgroups.

7.2.7.2 Creating a Group object

To create a **Group** object, complete the following steps:

1. Go to the **Groups** tab.

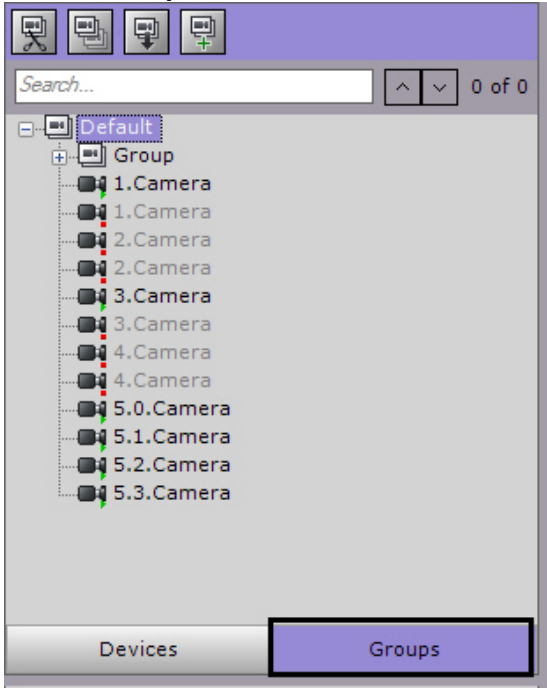

2. To create a **Group** object, click the  button or select **Add group** in the context menu of the main group.

Note

By default, an object (whose name is the same as the Axon-domain) is available, including all cameras that have been created in the system. This object is referred to here and elsewhere in the document as the "main group". This object cannot be deleted. Cameras in this group cannot be deleted.

3. Specify the group name in the **Name** field.

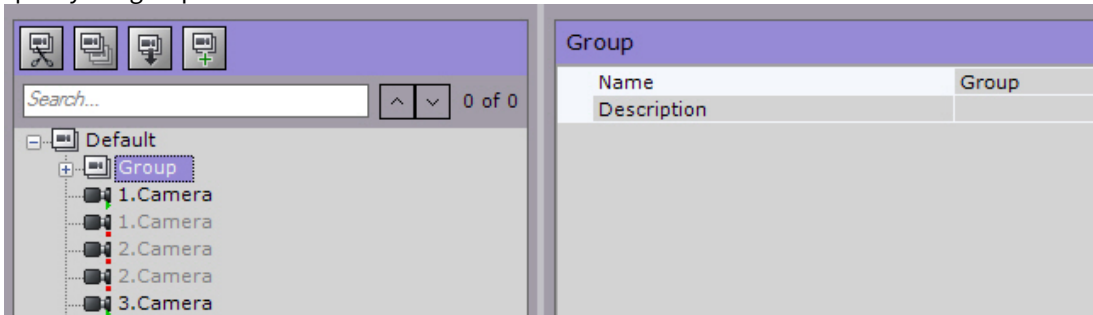

4. Enter a description of the group in the appropriate field.
5. Click the **Apply** button.

The **Group** object has now been created.

7.2.7.3 Adding video cameras created in the system to Group objects



To add video cameras to groups, complete the following steps:

Note

Video cameras are added to groups via management operations (see the section titled [Managing Group and Video camera objects](#)). The standard method for adding video cameras to groups is presented below

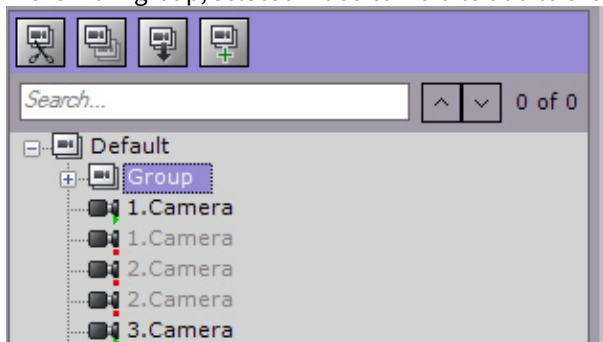
1. In the main group, select a video camera to add to the selected group.



2. Click the  button or select **Copy** from the context menu of the selected video camera.
3. Select the **Group** object to which you need to add the video camera.
4. Click the  button or select **Paste** from the context menu of the selected group.
5. Fill the groups with the necessary video cameras (see steps 1-4).

Note

One video camera can be assigned to multiple groups

6. Click the **Apply** button.

Adding video cameras to groups is now complete.

7.2.7.4 Creating a system of groups and subgroups

Groups can be included within other groups, forming a system of groups and subgroups.

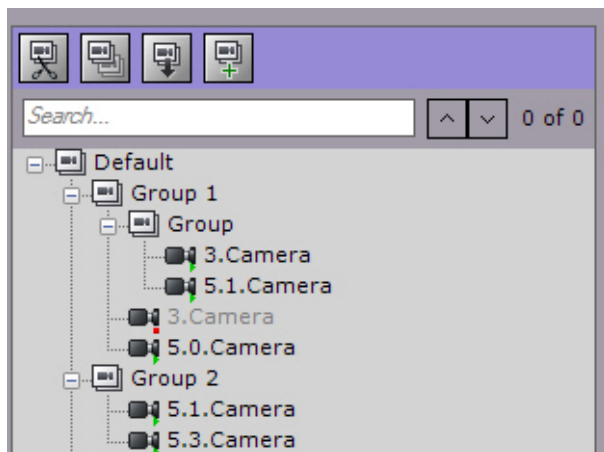



A system of groups and subgroups can be created via group management operations and video camera management operations (see the section titled [Managing Group and Video camera objects](#)).

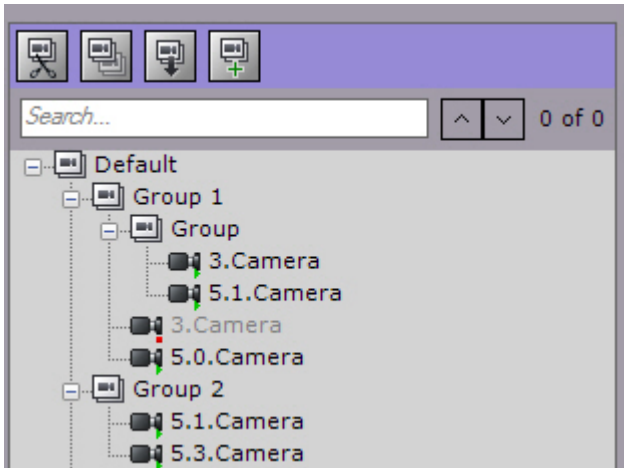

Group objects can be moved or copied to other **Group** objects or to the main group.

7.2.7.5 Managing Group and Video camera objects

The main operations used to manage groups and video cameras are presented in table.



Action	Execution
<p>Cut/Paste</p> <div style="border: 1px solid gray; padding: 5px; margin: 10px 0;"> <p>Note</p> <p>You can cut a Video camera object only from a Group object.</p> <p>You cannot cut a Camera object from the main group. It is also impossible to cut the main group.</p> </div>	<p>Using your mouse:</p> <ol style="list-style-type: none"> 1. Left-click and hold the Video camera/Group object. 2. Drag the object to the Group object (or to the main group if you are dragging a Group object). 3. Release the left mouse button. <p>Using the toolbar:</p> <ol style="list-style-type: none"> 1. Left-click the Video camera/Group object that you want to move. 2. On the toolbar, click . 3. Left-click the Group object (or the main group, if one of the Group objects is being moved) to which you want to move the Video camera/Group object.. 4. On the toolbar, click . <p>Using the keyboard:</p> <ol style="list-style-type: none"> 1. Left-click the Video camera/Group object that you want to move. 2. Press the key combination Ctrl+X. 3. Left-click the Group object (or the main group, if one of the Group objects is being moved) to which you want to move the Video camera/Group object.. 4. Press the key combination Ctrl+V.
<p>Copy/Paste</p>	<p>Using your mouse:</p> <ol style="list-style-type: none"> 1. Left-click and hold the Video camera/Group object while simultaneously holding down the Ctrl key. 2. Drag the selected object to the Group object (or to the main group, if the Group object is being copied). 3. Release the left mouse button.

Action	Execution
	<p>Using the toolbar:</p> <ol style="list-style-type: none"> 1. Left-click the Video camera/Group object that you want to copy. 2. On the toolbar, click . 3. Left-click the Group object (or the main group, if one of the Group objects is being copied) to which you want to copy the Video camera/Group object.. 4. On the toolbar, click . <p>Using the keyboard:</p> <ol style="list-style-type: none"> 1. Left-click the Video camera/Group object that you want to copy. 2. Press the key combination Ctrl+C. 3. Left-click the Group object (or the main group, if one of the Group objects is being copied) to which you want to copy the Video camera/Group object.. 4. Press the key combination Ctrl+V.
<p>Deletion</p> <div style="border: 1px solid #ccc; padding: 5px; margin-top: 10px;"> <p>Note</p> <p>You can delete a Video camera object only from a Group object. You cannot delete a Camera object from the main group.</p> </div>	<ol style="list-style-type: none"> 1. Left-click the Video camera/Group object that you want to delete. . 2. Press the Delete key.

7.2.8 Autocopy data from local to centralized servers

Axxon Next VMS supports automatic copying of the archive (video, audio, alarms) and camera events from local servers that are not in the same Axxon domain with the centralized server

Note

This is useful, for example, in the following case:

- The video from a bus on the route network is written to a temporary archive on the local server specific for each bus;
- When the bus arrives at the depot, the archive and camera events are automatically transferred to the centralized server.

To use this option, configure the centralized server as follows:

1. Manually add the **Interop** IP device to the configuration (see [Adding and removing IP devices](#));

IP address	Port	Vendor
<input type="text" value="0.0.0.0"/>	<input type="text" value="80"/>	<input type="text" value="Interop"/>
Device type		Model
<input type="text" value="IP device"/>		Interop Device

2. Enable [The Embedded Storage object](#).
3. Specify the address of the device in the following format (**1**): <IP-address of local server>:<name of local server in Axxon domain>:<ID of camera on server>.

Attention!

The Server name is case-sensitive.

If the name is Server1, no connection will occur if you enter server1 or SERVER1.

Object features	
1	Address  10.0.11.64:Server1:16
2	Port 80
	MAC address
	Manufacturer Interop
	Model Interop Device
	Driver version 3.0.0
	Break unused connections No
	Current firmware
	Device serial number
	Low GOP No
	Synchronous correction of time stamp No
	Video channel No. 0
Authentication	
	Default Yes
3	Username root
	Password ••••
Video buffering	
	Buffer size 0
Video stream settings	
4	Live video mode Yes
Panomorph	
	Activate No
	Camera position Wall
	Lens type Common fisheye-lens
	View type PTZ
	Fit to frame No
Other	
5	Maximum speed x32
6	Transport protocol TCP

4. Specify a port of the local Server from which data is transmitted (**2**). If you use TCP protocol (see 8), please specify the RTSP port number (554 by default, see [Configuring an RTSP Server](#)). If you use rtspoverhttp or rtspoverhttps protocol, specify the web server's port (80 by default, [Configuring the web server](#)).
5. Specify the user name and password (**3**). The user must have permissions to access the local server.
6. If you want to display live video from the local server when it is available, select Yes in the appropriate field (**4**).
7. Specify the maximum playback speed (**5**).
8. Select the data transfer protocol (**6**).
9. Click the **Apply** button.
10. Repeat the above steps for all the required cameras from all local servers.
11. Configure automatic replication from the embedded storages of the added devices to the centralized server archive (see [Configuring data replication](#)).

Attention!

With a high network load, there may be gaps in the centralized server archive.

You have successfully set up automatic data copying from the local servers to the centralized server.

7.3 Configuring Archives

7.3.1 General information of configuring archives

You can configure archives using the interface in the **Archive** tab (under **Settings**). To create archives you must have the appropriate permissions.

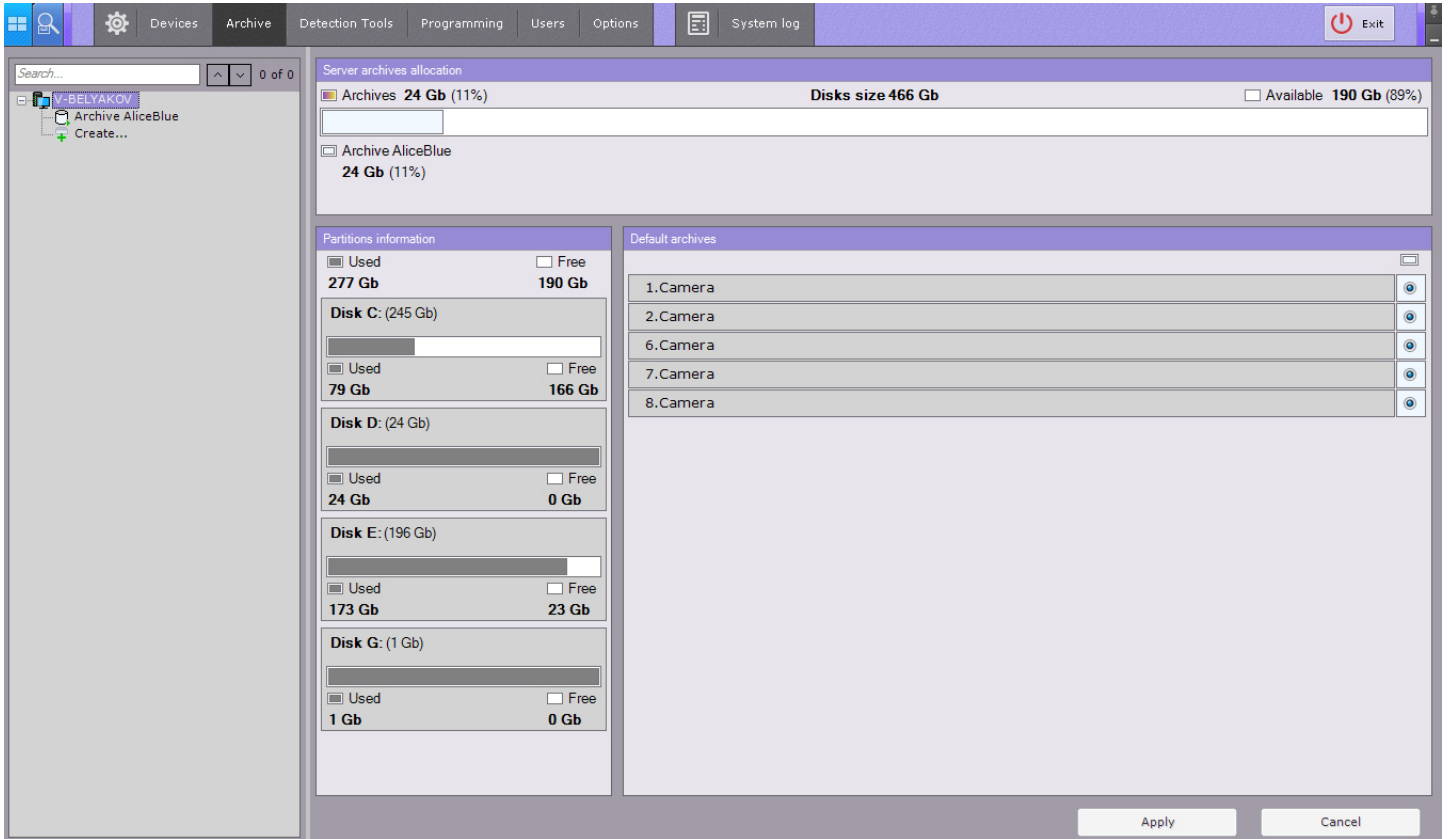

On the base of one server you can create an unlimited number of archives.

Attention!

We do not recommend you to operate a large single volume video footage archive.
It's more practical to divide the archive to multiple volumes located on different hardware devices.

An archive can be placed on local disks or on network disks.

To compare these types of archives, review the following table.

Local archive	Network archive
An archive can be distributed on several volumes of the server	Archive can be stored on multiple network storage devices.
On one logical disk for one archive you can create only one volume, which occupies either a file of a set size or the entire partition (logical disk).	Archive can be stored only as a file of a specified size.
An archive can contain multiple volumes, which may be in the form of a file or a partition.	

Data can be copied between archives.

You can configure archives as follows:

1. Create archives.
2. Configure recording of the video stream from video cameras to the archives.
3. Configure data replication, if necessary.

7.3.2 General information of SolidStore file system

Fragmented files accumulate over time in the Windows file system. This is due to the fact that the operating system sequentially fills the free disk space when writing files.

Free disk space, which appears when old files are deleted, can be located in different parts of the disk; therefore, each file can be split into many fragments.

When reading or writing such a file, the hard drive head must constantly move, which reduces the read/write speed and causes mechanical wear of the disc.

AxonSoft has developed its own file system SolidStore especially for storing video archives. The system is installed on a blank physical or logical drive, which is fully allocated to Axxon Next video archive (see [Creating archives](#)). In developing SolidStore, it was taken into account that recording will only be sequenced in one direction (looping mode), and the newest data is written in place of the oldest. By optimizing the reading/writing process we managed to minimize the travel of the hard disk head along its surface and to achieve three important advantages:

- Enable high read/write speeds, approaching the physical access speed limit of the hard disk.
- Increase the service life of the hard disk.
- Solve the problem of data fragmentation: as data is written only in looping mode, fragmentation is minimal and does not accumulate with time. This way, the read/write speed remains high throughout the operation of the video surveillance system.

SolidStore relieves the user from the need to periodically stop the video surveillance system and run the Disk Defragmenter tool. This significantly increases video surveillance uptime and the protected facilities remain under the watchful eyes of the security personnel.

If it is not possible to allocate a separate disk for Axxon Next video archive, it can be written as a regular file in the existing Windows file system.

7.3.3 Creating archives

7.3.3.1 Creating a local archive

To create a local archive:

1. In the branch of the **Server** object corresponding to the computer on which you need to organize an archive, click the **Create** link.

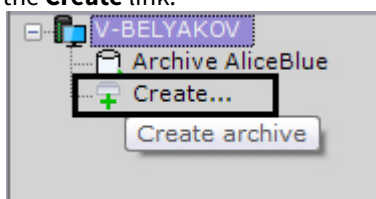

Note

You can also create an archive by selecting the matching command in the context menu of the **Server** object (the menu can be brought up by right-clicking the name of the Server)

2. Highlight the **New archive** link which appears (1).

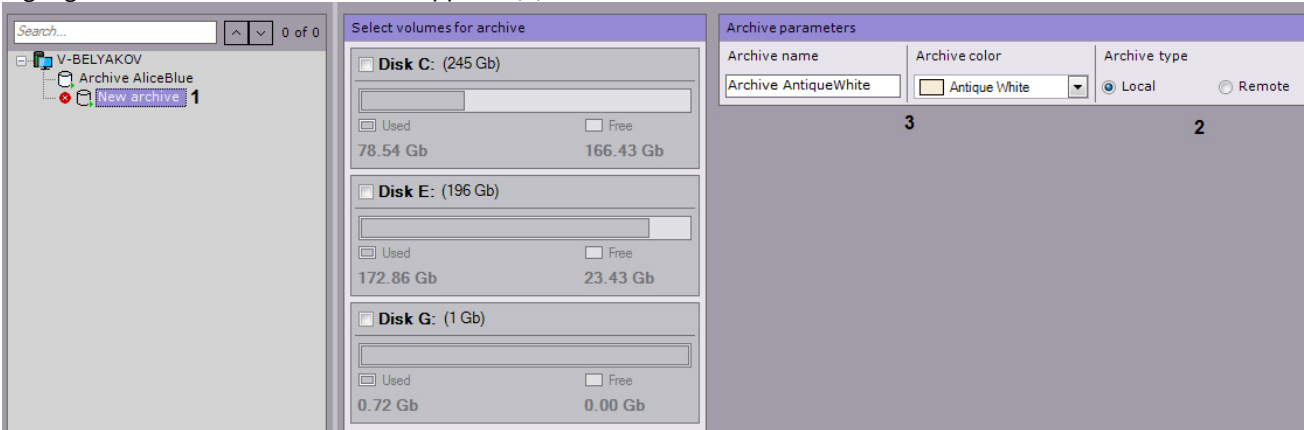

3. Set the archive type to **Local**.

4. Specify the name and color of the archive.

5. Configure archive volumes.

- a. For the disks that you want to include in the archive, select the corresponding check boxes.
- b. If a disk does not have a file system, the disk can contain an archive volume in the form of a partition. In this case, select the **Formatting** check box. This will format the disk using the SolidStore file system developed by AxxonSoft (see [General information of SolidStore file system](#)).

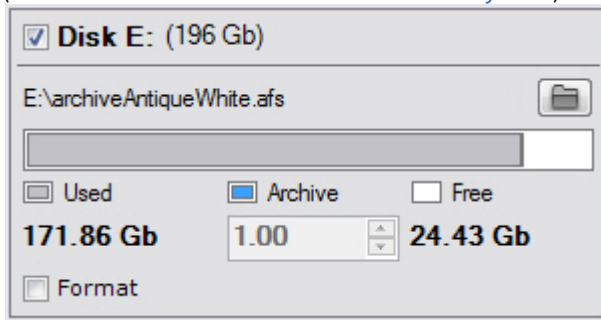

Note

The file system on the disk can be erased by using the standard Disk Management utility in Windows. Instructions for starting and using the utility are given on the [Microsoft website](#).

Deleting the file system on the disk in the disk management utility consists of the following:

- i. Delete the volume.
- ii. Create a new volume in the resulting unformatted area.
- iii. Assign a letter to the volume, but do not format it.

The system disk cannot be completely allocated for an archive

Important!

When selecting the disk on which to place the archive volume, take its size into account. If the archive is completely filled, the oldest data will be overwritten with new data.

Note

Note that you cannot create an archive volume as a partition on a removable disk, since its partition cannot be erased through the Disk Management utility

- c. On disks that have a file system, you can store an archive volume in the form of a file.

For this archive volume, you must enter a file size (in gigabytes) or set it by moving the slider. The size of the archive file must be more than 1 GB. For the Fat32 file system, the maximum archive size is 4 GB.

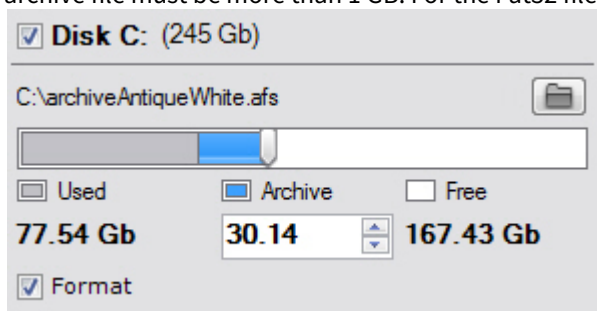

Important!
If the archive is completely filled, the oldest data will be overwritten with new data.

Note
By default, the file name will be the same as the name of the archive, and the file will be located at the root directory of the disk. To change the name and/or location of the file, click the  button.

6. Click the **Apply** button.

If volumes are configured in the form of partitions, a dialog box is displayed, warning about formatting of the relevant system disks.

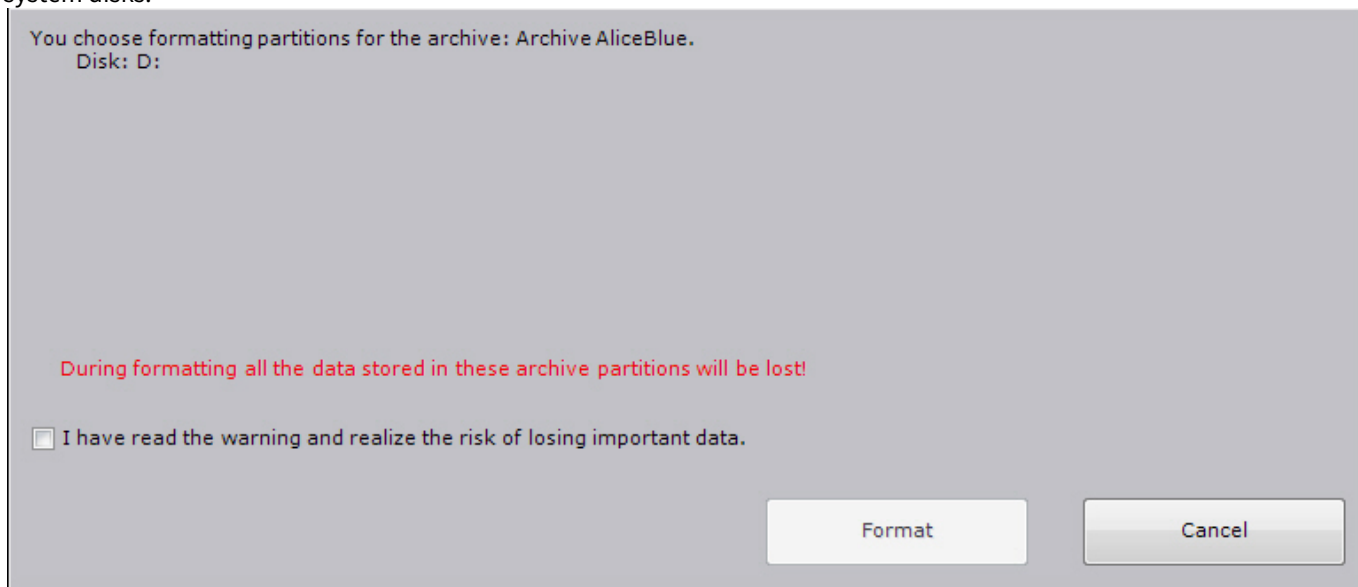

7. Read through the list of partitions that will be formatted. If the list is correct, select **I have read the warning and realize the risk of losing important data**, then click **Format**. Otherwise, click **Cancel** to return to the archive settings.

Creation of the local archive is now complete.

7.3.3.2 Creating a network archive

Network archives are files on NAS (network attached storage).

To create a network archive, do as follows:

1. Go to the **Server** object and click the **Create** button.

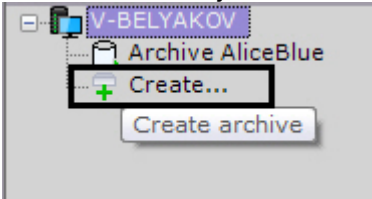

2. Set the archive type to **Remote (1)**.

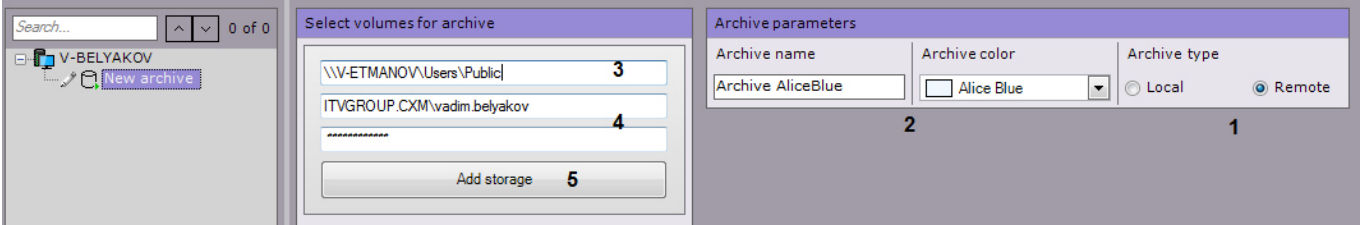

3. Specify the name and color of the archive (2).
4. Enter a path to the archive network destination (3).

Attention!

If a particular PC is used to access a particular network archive from multiple user accounts, do the following:

- a. Launch text editor and open the file: C:\Windows\System32\Drivers\etc\hosts, then add the following string: "192.168.1.1 DNSname1", where 192.168.1.1 - IP address of the NAS, DNSname1 - domain name of the NAS.
- b. The name of a newly created network archive must include the actual domain name.

If you need to add several network archives under different user accounts, do the following:

- a. Launch text editor and open the file: C:\Windows\System32\Drivers\etc\hosts, and add IP addresses and domain names of all necessary NAS.
- b. The names of newly created archives must include actual domain names.

In a backup Server-driven failover system (see [Setting up a configuration with the backup Server](#)), if domain names differ from one Server to another, the hosts file on the backup Server must include records from all Servers.

5. Enter the user name and password (4). The user must have permissions to access the NAS.

Attention!

The login should be specified with a prefix of the domain (domainname\username) or name of the computer (computername\username) where this account is located.

6. Click the **Add storage** button (5).

This will connect you to the NAS. When you are connected, you can see a dialog box for setting up your archive.

Attention!

Only one network user can connect to NAS at a time. This is a limitation of OS *Windows*.

If this error occurs, disconnect the previous user in one of the following ways:

1. Run the command `net use /delete`.
2. Use **PsExec** to open the command prompt as the LocalSystem user (`psexec.exe -i -s cmd.exe`) and execute the same command.

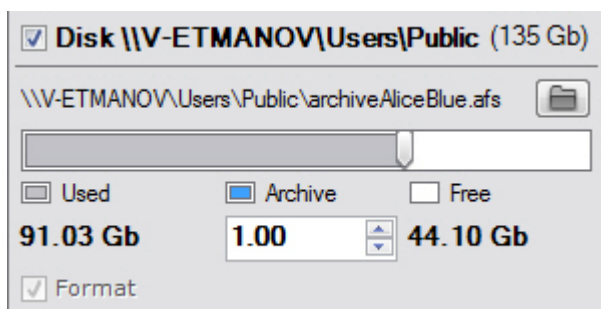

7. For this archive volume, you must enter a file size (in gigabytes) or set it by moving the slider. The size of the archive file must be more than 1 GB. For the Fat32 file system, the maximum archive size is 4 GB.

Note

To change the archive folder, click the  button and browse to a desired location

8. If you want, you can add other NAS for your archive and set them up.
9. Click the **Apply** button.

You have created your network archive. After creating the archive, the NAS status is displayed.

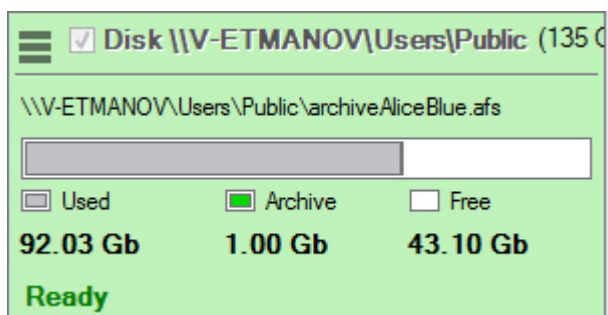

7.3.3.3 Creating an archive based on existing archive volumes

If an archive is created from an existing volume, it will be possible to extract saved video from the file only if the following conditions are met:

- The currently selected computer has the same name as the name of the Server or node on which the video has been saved to an existing Video Footage volume.
- The IDs of the video cameras from which the recordings were written to the existing archive volume are the same as the IDs of the current video cameras.

To create an archive based on an existing volume:

1. Create an archive (see [Creating a local archive](#)).
2. Select disks or network archives that contain existing volumes (by selecting check boxes, **1**).

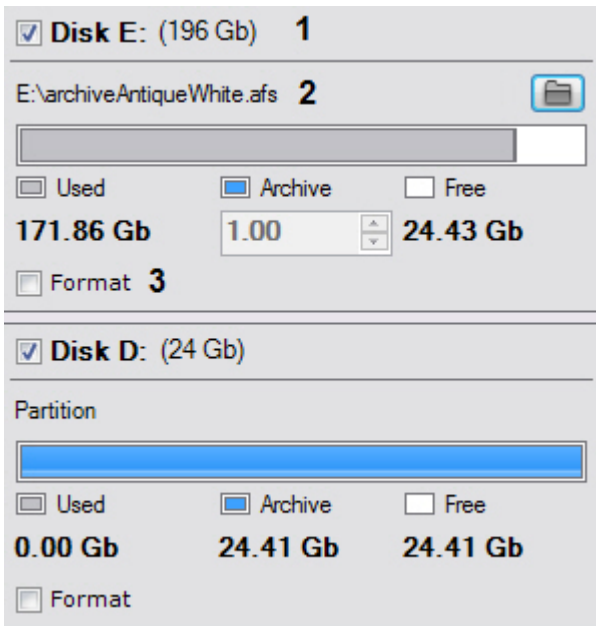

Note

A new archive can contain volumes that previously belonged to different archives

3. If the volume is in file form, select the archive file to which recording was performed (2).
4. Clear the **Format** check box (3).

Note

If the **Format** check box is selected, the archive entries that are currently stored on the volume will be erased.

5. If necessary, create new archive volumes on free partitions.
6. Click the **Apply** button.

The archive is created and, if all requirements are met, the archive recordings are available.

7.3.4 Binding a camera to an archive

Video and audio streams are recorded synchronously.

Binding a camera to an archive determines the archive to which a video stream will be recorded and how.

You can bind a single camera to an archive or bind a group of cameras by using the same settings.

To bind a camera to an archive:

1. Select the new archive.
2. Select the check box that corresponds to the camera for which you want to configure archive recording (1).



3. Configure settings for archive recording.
 - a. In the **Constant recording** list, select the archive recording mode (2).
 If **No** is selected, the video stream will be recorded to the archive only when an operator manually initiates an alarm or an automatic rule is initiated.
 If **Always** is selected, video will be recorded to the archive non-stop.

If a time schedule is selected (see [Configuring schedules](#)), video will be recorded non-stop to the archive during the selected time period. Recording to the archive can also be initiated by the operator or an automatic rule.

- b. In the **Depth** field, specify a video footage retention time value for the given camera (in days). **Zero** value means unlimited retention.

Attention!

If your footage archive includes videos from one or more cameras with unlimited retention, the archive will run out of free space at some point, and FIFO based re-recording will be automatically started regardless of retention time settings. In this case, we cannot guarantee that the actual retention time settings will be preserved for other cameras.

Therefore, if you set unlimited retention time for at least one camera, you may find it pointless to limit retention time for other cameras.

To avoid retention time collisions between cameras, please make sure to provide enough storage capacity for your footage archive (see [Disk storage subsystem requirements](#)).

Attention!

Further, if you are increasing the available archive retention time, or setting the parameter to **0**, please note that this setting may be not applied to earlier records. Older footage falling outside the initial retention time may become inaccessible.

Note

When setting a retention time parameter for a particular camera archive, please note that global retention time limits have higher priority (see [Configuring access restrictions to older footage](#)).

If your entire archive is set to, say, 10 days, and the camera retention time is set to 20 days, camera footage will be actually retained for 10 days only.

- c. In the **Pre-alarm recording time** field (**4**), enter the buffering time of the video stream from the camera in seconds. This value should be in the range [0, 30].

Note

Pre-alarm recording is the period of pre-event recording that will be added to the beginning of an alarm event recording

Attention!

If a macro starts recording, the pre-alarm recording time may be longer, according to your settings (see [Record to archive](#)).

- d. If you want to record pruned, decimated video, choose **By keyframes** from **Gapping, fps**. This applies to all video streams except MJPEG. With MJPEG codec, please use the explicit value of frame rate. Video pruning by frame dropping reduces the size of recorded video and saves storage, but video with skipped frames feels like the movement is delayed, and motion feels more choppy.

Attention!

When you prune by frame dropping, in all video streams except MJPEG , only I-fames (Intra-Coded Frame or Key Frames) are saved. Different codecs feature various compression levels with key frames rates going down from 3 to under 1 I-frames per second.

MJPEG video contains only I frames (Intra-coded pictures with a complete image), so it makes sense to set a desired frame rate here.

- e. Select a stream for archive recording (6).

Note

This setting is relevant for cameras that support multistreaming.

- 4. Click the **Apply** button.

Binding of the camera to the archive is now complete.

To bind multiple cameras:

- 1. Select the check boxes next to the cameras for which you want to configure archive recording. To select all cameras, select the **Select all** check box.

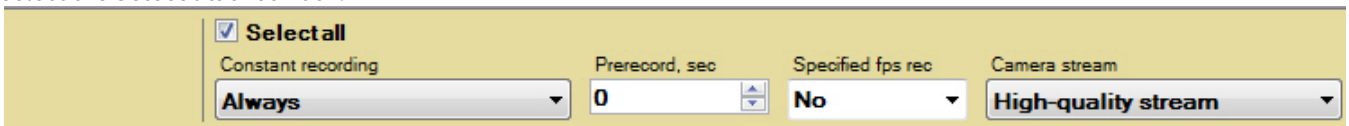

- 2. Configure archive recording settings for the group of cameras (marked with yellow). The indicated settings for archive recording are applied to the selected cameras.
- 3. Perform custom configuration of camera recording settings, if necessary.
- 4. Click the **Apply** button.

The camera is now bound to the archive.

7.3.5 Setting the default archive

The default archive of a video camera is the archive to which images from a given video camera are recorded during user-initiated alarms. For each video camera one and only one default archive must be set. The first archive to which recording of a video stream from a video camera was configured automatically becomes the default archive (see [Binding a camera to an archive](#)).

To switch the default archive for a camera:

- 1. Select a **Server** object.

The **Default archives** form displays a list of cameras and archives, which are marked with the corresponding colors. If archive recording to at least one archive is enabled for a particular camera, the camera is visually marked as related to its default archive.

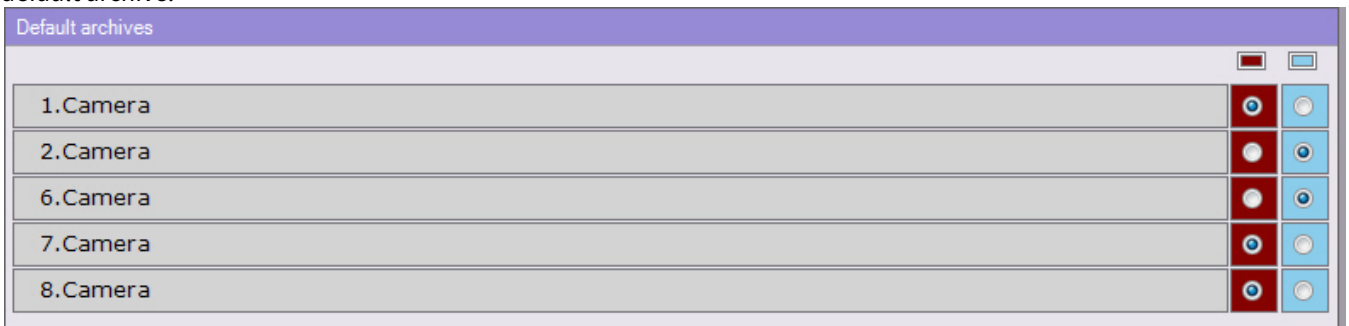

- 2. To change the default archive for a camera, move the designator to the relevant archive.

3. Click the **Apply** button.

Configuration of the default camera archive is now complete.

7.3.6 Configuring data replication

Replication of archives refers to constant, block-by-block copying of fixed-size information (video, audio, metadata) from one archive to another archive on the same Axxon-domain.

Attention!

Replication occurs as information blocks are accumulated. 1 block may contain more than a minute of video.

Attention!

Replication is performed only to the end of the archive. It is not possible to overwrite existing data in the archive.

To transfer the old data from **Archive 1** to **Archive 2** and continue writing new data to Archive 2, do as follows:

1. Replicate the data from **Archive 1** to **Archive 2**, while **Archive 2** cannot be written to.
2. Configure the camera to write to **Archive 2**.

Note

The primary purpose of data replication is to ensure long-term storage and access to multimedia recordings on remote storage devices.

Any archive can be the source or recipient of replication. Moreover, every archive can simultaneously be both the sender and recipient of data.

Note

Events indicating the start and successful completion of data replication are generated in the system (see [Event Control](#)). These events can be used as macro triggers

To configure data replication:

1. In the list of archives on the Axxon-domain, select the archive to which you want to copy data from other archives.
2. Select one or more archives from which you want to copy data (1). You can also replicate video from on-board camera storage (4, see [The Embedded Storage object](#))

The screenshot shows a configuration interface for data replication. It features two main sections, each representing an archive. The top section is for 'Archiv AliceBlue (V-BELYAKOV)' and is marked with a '1' and a checkmark. It has a 'Replication period' dropdown set to 'On demand' (marked with a '3') and a 'Cameras for replication' section (marked with a '2') containing three checked items: '1.Camera', '2.Camera', and '3.Camera'. The bottom section is for '4.0.Embedded storage (4.Camera) (V-BELYAKOV)' and is marked with a '4' and a checkmark. It has a 'Replication period' dropdown set to 'Always' and a 'Cameras for replication' section containing one unchecked item: '4.Camera'. Each section includes a cylinder icon representing an archive.

3. For each archive, select the cameras from which data will be copied to the source archive (2). To select all cameras, click the **Select All** button.

Note

Data for a particular camera can be copied to the source archive only from one archive. When you select a camera for replication from an archive, the camera becomes unavailable for replication from any other archive.

Note

You cannot select cameras if they are already being recorded to the source archive.

4. Select replication period (**3**):
 - a. **Always** - replication is performed continuously.
 - b. **On demand** - replication is performed manually.

Attention!

You can use macros to replicate on schedule (see [Start replication](#)).

5. Click the **Apply** button.

You have now configured data replication. If you have chosen the **Always** replication period, data replication starts immediately after changes are applied.

7.3.7 Configuring access restrictions to older footage

You can make only newest recordings in your available for the VMS users.

To do this, select the history (in days) in the appropriate field and click **Apply**.

Archive parameters				
Archive name	Archive size	Depth, days	Filled archive volume	Archive state
AliceBlue	20.78 Gb	0	0% : 0.00 Gb	Ready

Note

If the history value is set at **0**, all recorded video is available for playback.

You can view only video recordings not exceeding the retention time setting. All other videos will be deleted.

Attention!

Further, if you are **increasing** the Archive retention time (**0** - stands for unlimited time), this setting is applied for new records only. Earlier records falling outside the initial retention time become inaccessible.

7.3.8 How to preserve Video Footage continuity after replacing a video source

Axxon Next supports keeping video source's recorded footage after the device is replaced.

To do this:

1. Copy the old video device ID and delete it from the system.

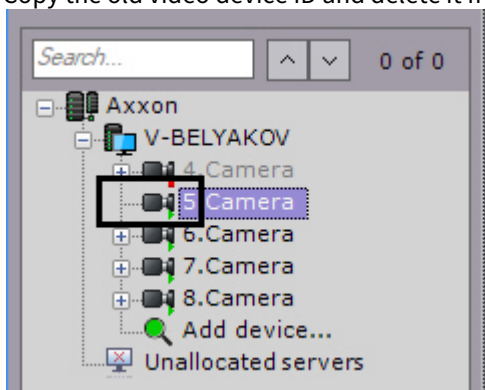

2. Create a new device under the same ID (**1**) and bind it to the same footage archive (**2**, see [Adding and removing IP devices](#)).

IP address	Port	Vendor	Username	Bind to the archive	ID
10.0.11.56	3600	360Vision	Auto	AliceBlue 2	5 1
Device type		Model	Password	Recording	Name
IP device		Predator Pred-XX-IP	••••	Always	Auto

Attention!

Any other parameters of the new device may differ (make and model, ID, etc.).

If you swap NVRs, make sure you preserve the same order of video channels for connected cameras.

Creating a new device with the old ID makes the previously recorded footage available for viewing / processing within the system.

7.3.9 Protecting video footage from FIFO overwriting

In the *Axxon Next* software package, data is being recorded cyclically (First In First Out). Normally, older video footage is overwritten by the newer.

You can protect selected videos from being overwritten. A macro copies protected recordings to another Video Footage.

To protect videos, do the following:

1. Configure on-demand replication (see [Configuring data replication](#)).
2. Configure a macro (see [Setting up a macro for automatic copying of protected records](#)).
3. Configure protection for necessary videos (see [Setting up record protection](#)).

You can further edit the list of protected recordings through the web client.

7.3.9.1 Setting up a macro for automatic copying of protected records

You have to create and set up a **cyclical** macro (see [General information about the macros](#)) as follows:

1. First action in the macro must be the [Awaiting](#) (1).

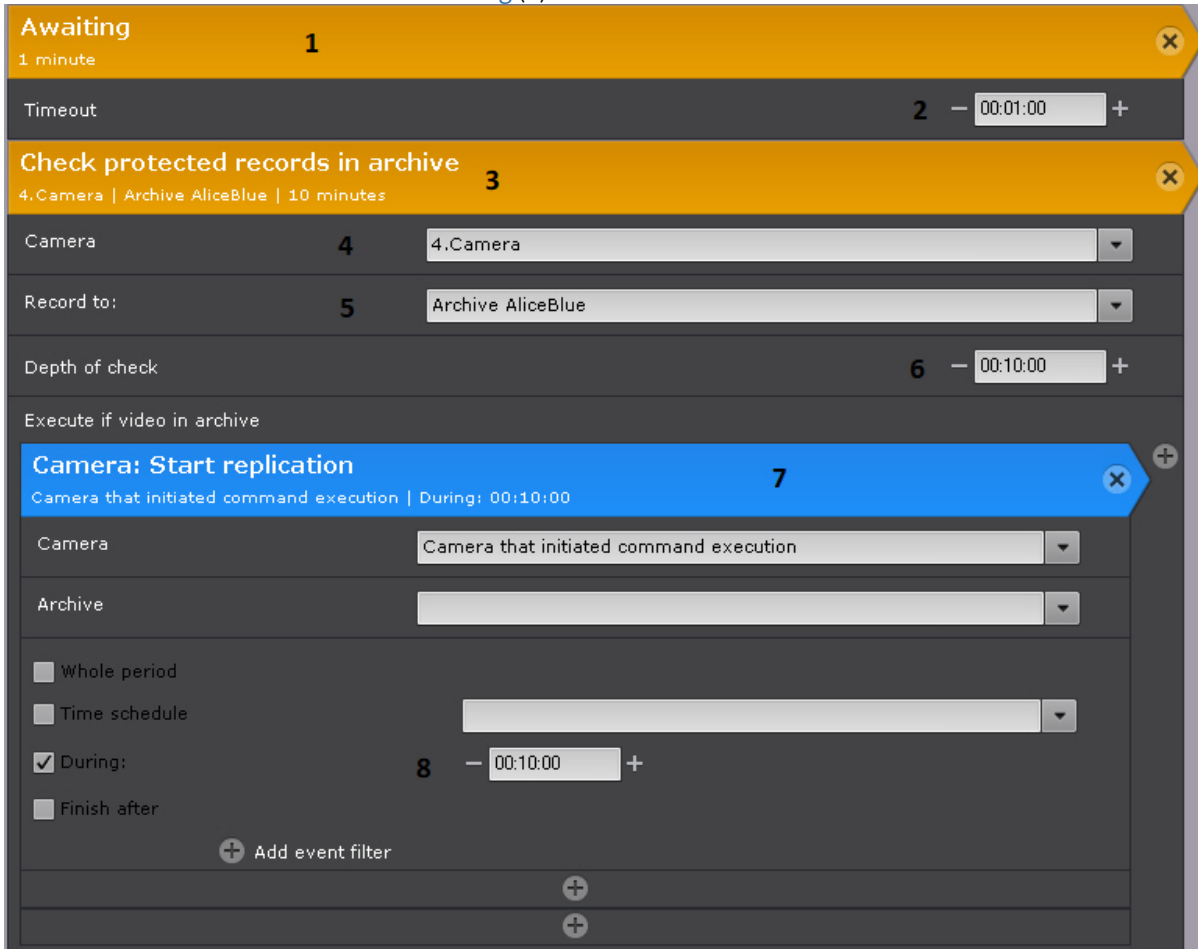

2. The timeout delay value sets the time interval for checking Video Footage for protected records (2).
3. The second action in the macro must be checking Video Footage for protected records (3). On this step, you have to:
 - a. Select a camera or a group of cameras whose Video Footages have to be checked for protected records (4).
 - b. If you select a particular camera, specify the archive to be checked (5). If a group of cameras was selected in the previous step, only default archive will be checked for each of them (see [Setting the default archive](#)).
 - c. Specify the depth of the check in HH:MM:SS format (6). The time interval between checks is calculated as follows: [starting time of the earliest recording in archive, starting time of the earliest recording in archive + depth of the check].
 - d. Add data replication as a conditional action upon discovery of protected records within the scanning interval (7, see [Start replication](#)).
 - e. Select the Replication time for a time interval (8). The replication duration defines the time interval from which protected records have to be copied to another Video Footage. All protected intervals starting within the [starting time of the earliest recording in Video Footage; starting time of the earliest recording in Video Footage + replication duration] range will be copied to Video Footage for replication. Normally, the replication duration has to be equal to the depth of the check defined in Step 3c.

The screenshot shows settings that make the system scan once in a minute (2) for protected records in Camera 4's (4) archive AliceBlue (5) within the [starting time of the earliest recording in archive + 10 minutes] time interval (6). If this interval contains protected records, the replication will be launched to copy all protected records falling into [starting time of the earliest recording in archive; starting time of the earliest recording in archive + 10 minutes] (8) interval to archive specified for replication.

7.3.9.2 Setting up record protection



To protect a record, create a bookmark (one of the annotation tools)

To create a bookmark, do as follows:

1. Select the required camera on the layout and proceed to archive mode (see [Switching to Archive Mode](#)).

Note

If you need to protect the same time interval in multiple camera archives, switch the necessary cameras to archive mode.

2. Set the protected time interval on the timeline with  and  buttons (see [The Timeline](#)).

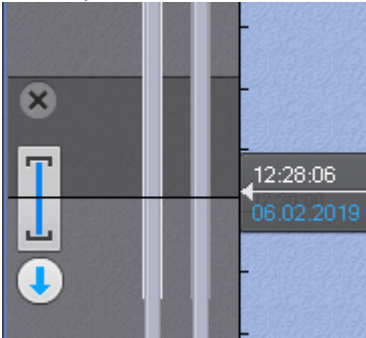

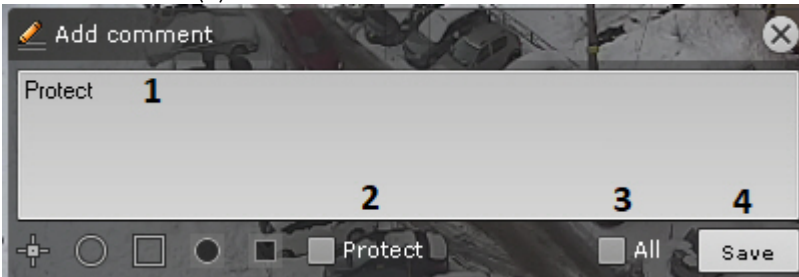

3. Click  in the Camera window.
4. Enter a comment (1).

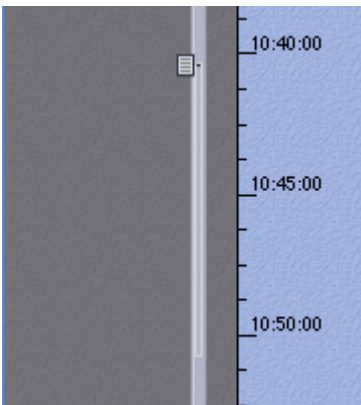

5. Check the **Protect** box (2).
6. Check the **All** (3) box if you need to protect the specified interval for all cameras currently in archive mode.
7. Click the **Save** button (4).

The newly created bookmark will appear on the timeline.



The protected interval will be highlighted in light grey while its beginning will be marked with .

7.3.10 Increasing capacity of an archive volume

You can increase capacity of an archive volume.

7.3.10.1 Increasing capacity of an archive volume as a partition

You can increase volume capacity only with standard media. This option does not work with RAID disk sets.

Attention!

AxxonSoft cannot guarantee archive data integrity after this action is complete.

To increase volume capacity, do the following:

1. Stop the Axxon Next Server (see [Shutting down a Server](#)).
2. Use the Windows disk management utility to [increase](#) volume capacity.
3. Start the Server (see [Starting a Server](#)).

7.3.10.2 Increasing capacity of an archive volume as a file

To increase volume capacity, use the `-expand` parameter in console utility for working with archives (see [Console utility for working with archives](#)).

7.3.11 Editing archives

You can edit the archives that have been created in the system. You can perform the following actions on them:

1. Rename an archive (see [Creating archives](#)).
2. Add new volumes. Addition of a new volume also occurs during archive creation (see [Creating archives](#)).
3. [Deleting and formatting archive volumes](#).
4. Change settings for archive recording (see [Binding a camera to an archive](#)).
5. Change replication settings (see [Configuring data replication](#)).

7.3.12 Deleting and formatting archive volumes

You can delete and format archive volumes.

To format the archive volume, do as follows:

1. Click the  button.
2. Select **Format volume**.

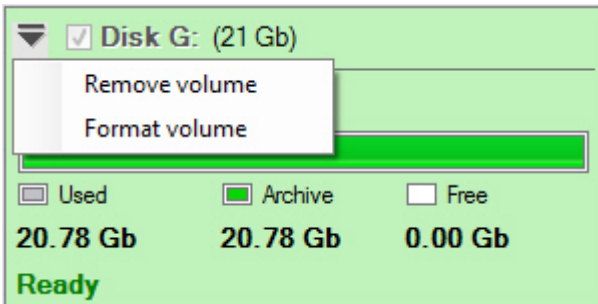

3. Click **Apply**. A dialog box is displayed, warning about formatting of the selected volumes.

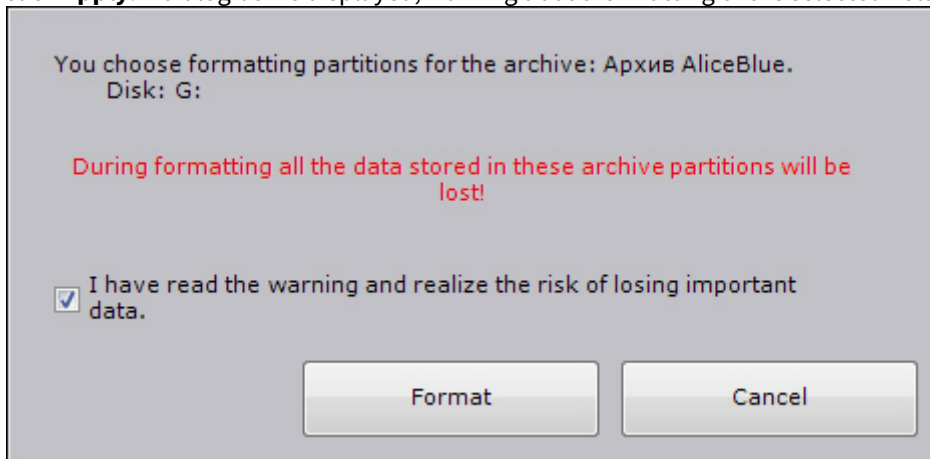

4. select the checkbox and click **Format**.

The volume formatting is complete.

To delete a volume, do as follows:

1. Click the  button.
2. Select **Remove volume**.

Note

If there is only one volume in the archive, you cannot delete it

3. Click **Apply**.
4. If required, you can remove archive files.

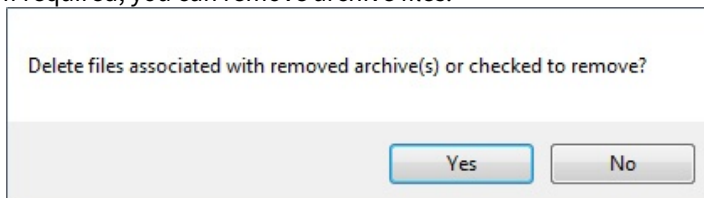

Attention!

If you delete archive files, all video footage contained will be lost.

If you do not delete archive files, you can re-use them to create another archive (see [Creating an archive based on existing archive volumes](#)). You can as well use a partition to re-create an archive.

7.3.13 Deleting archives

You can delete an archive from the system.

To delete an archive from the system, you must perform the following steps:

1. Select the archive to be deleted in the archive list.
2. Click the **Remove** button.
3. Click the **Apply** button.
If required, you can remove archive files.

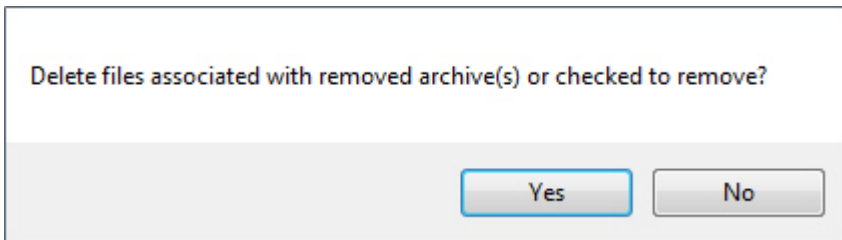

Attention!

If you delete archive files, all video footage contained will be lost.

If you do not delete archive files, you can re-use them to create another archive (see [Creating an archive based on existing archive volumes](#)). You can as well use a partition to re-create an archive.

Deleting an archive from the system is now complete.

7.3.14 View information about the size of archives and Server disk space.

Selecting a **Server** object displays statistical information about the available Server disks and created archives.

Figure 1 shows the overall balance of free disk space between the Server archives.

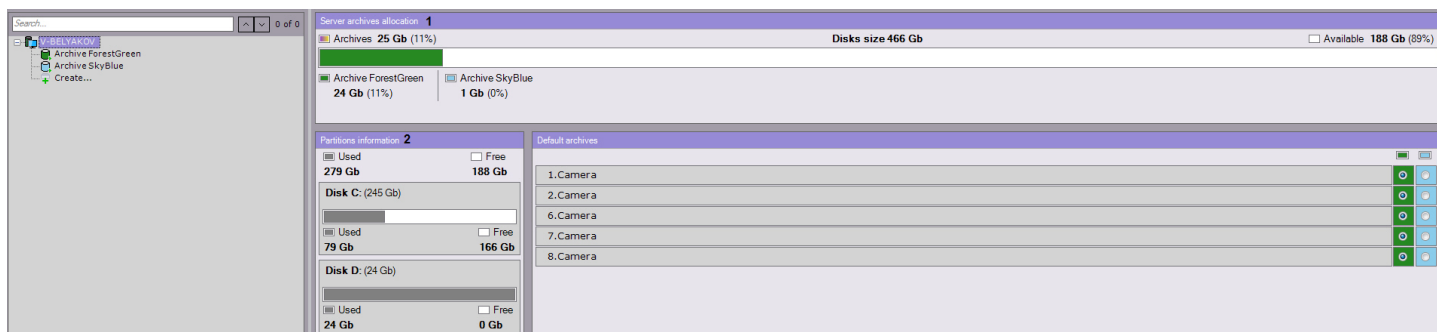

In addition, a list of disks is displayed, containing information about the total disk capacity, space used, and total free space (2).

When you select an archive, the following information is displayed:

1. The percentage of used space on each volume in the archive. This parameter indicates whether the volume's data is being rewritten. If the percentage is 100%, the new data is overwriting the old data.

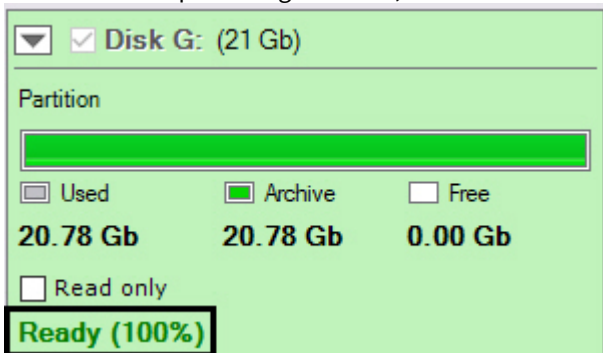

2. The approximate volume usage in percentage and gigabytes (2) is displayed in the **Filled archive volume** field of the **Archive Parameters** group.

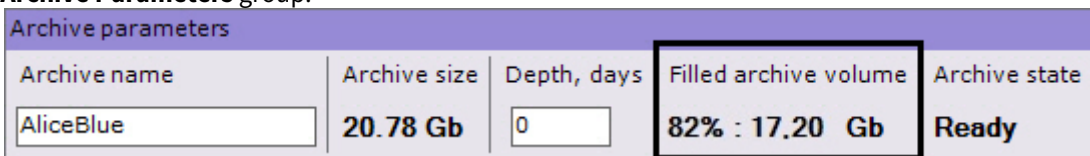

When you update *Axxon Next* or restart the Server, or create the archive based on the existing volume etc., the archive is reindexed.

Reindexing progress bar is displayed.

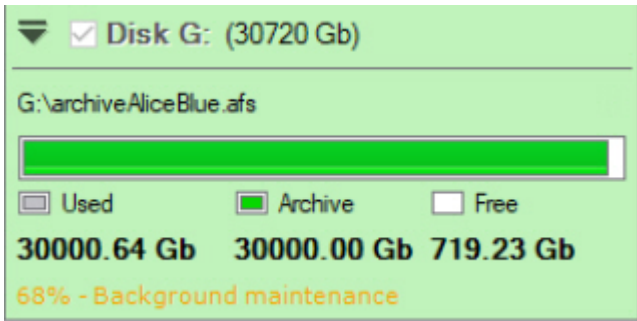

7.3.15 Saving the archive when replacing a video source

In *Axxon Next*, it is possible to save the archive in case of replacing a video camera, NVR or any other video source.

To do this:

1. Delete the old device, but keep in mind its ID.

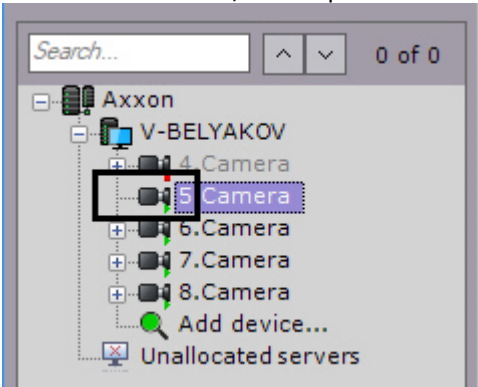

2. Create a new device in the system with the same ID (1) and bind it to the old archive (2, see [Adding and removing IP devices](#)).

IP address	Port	Vendor	Username	Bind to the archive	ID	+
10.0.11.56	3600	360Vision	Auto	AliceBlue 2	5 1	
Device type		Model	Password	Recording	Name	
IP device		Predator Pred-XX-IP	••••	Always	Auto	

Attention!

Device model, IP-address and any other device parameters may differ from the previous one.

In the case of replacing the NVR, the video cameras should be connected to the same channels as before. After creating a new device with the old ID, the archive recorded earlier will be available in the system.

7.4 Configuring detection tools

7.4.1 General Information on Configuring Detection

In the *Axxon Next* software package, several types of detection tools process incoming data:

1. Situation analysis detection tools.
2. Facial recognition tools.
3. Automatic number plate recognition tool.
4. Service detection tools:
 - a. Video analytics.

b. Audio analytics.

5. Detection tools embedded in a video camera.

Detection setup takes place using the interface in the **Detection Tools tab** (under **Settings**). For detection setup you must have the appropriate permissions.

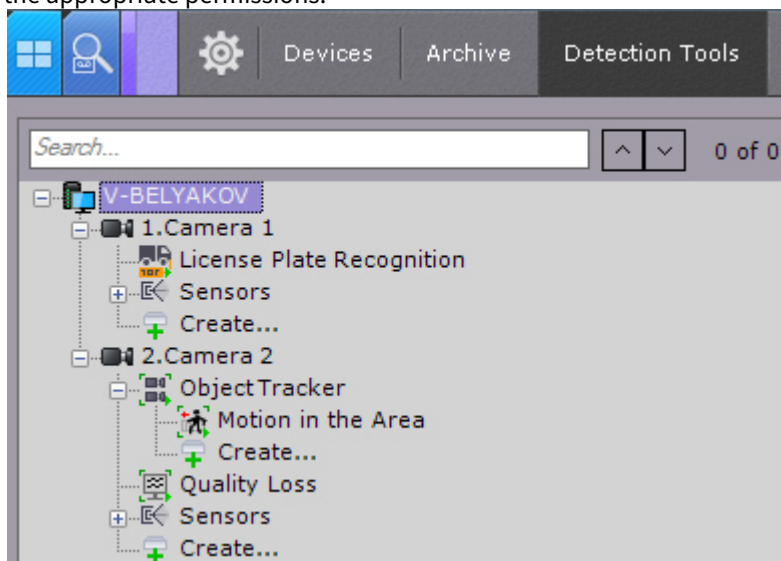

Attention!

For a video camera and its corresponding branch to appear in the Detection Tools list, the camera must be enabled in Axon Next

Note

By default, camera inputs that can be activated through an automatic rule are displayed on the list of detection tools.

In the viewing tile, on the right side of the detection configuration window, you can set visual parameters.

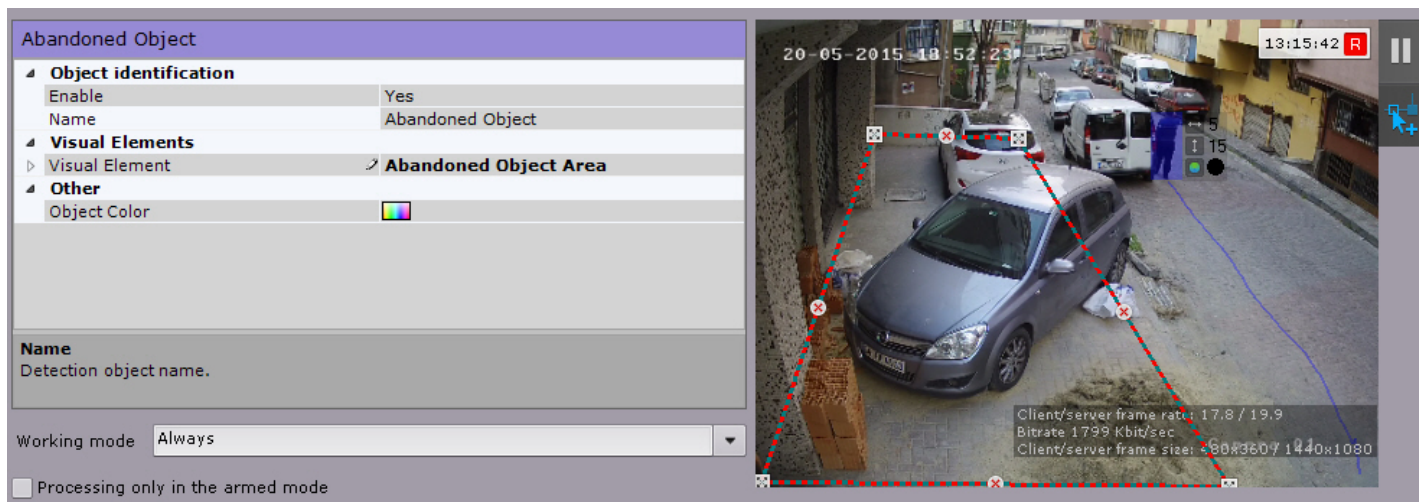

Note

The indicator in the upper right corner displays the current time and recording status (see [Time Display](#)).

The default system setting to a detection event is not to trigger any response actions. To set system response, create an automatic rule or a macro (see [Configuring Macros](#), [Automatic Rules](#)).

7.4.2 General information on metadata

Metadata is logical information extracted from video streams for easier camera management and retrieval of object-related content.

In *Axxon Next*, metadata can be obtained in two ways:

1. by analyzing video streams on Server;
2. by receiving metadata from edge devices (see [Embedded Detection Tools](#)).

The following tools are used for server-side analysis and metadata generation:

Attention!

To extract metadata from video, you have to de-compress and analyze the video stream which, in its turn, increases the Server's workload, thus limiting the number of available camera channels.

1. [Object Tracker](#).
2. [Neural Tracker](#).
3. [VMD](#).

Note

Object tracker and Neural Tracker generates metadata containing the following information about moving objects in scene: object type, position, size and color, motion speed and direction, etc.

VMD generates less accurate data; it does not detect object type and color.

4. [Face detection tool](#).

Note

Face detection metadata contain facial bounding boxes and their positions, as well as facial vectors.

5. [Automatic Number Plate Recognition \(LPR/ANPR\) tools](#).

Note

ANPR metadata contain license plate bounding boxes and their positions, as well as vehicle registration numbers.

6. [Pose detection](#).

Note

Metadata from pose detection tools contains information on positions and postures of all persons in FOV.

The metadata is used for the following system options:

Option	Required source of metadata
Scene Analytics	Object Tracker , Neural Tracker , built-in detection tool , or VMD .
Forensic search MomentQuest	Object Tracker , Neural Tracker , built-in detection tool , or VMD .
Face search	Face detection tool .

Option	Required source of metadata
LPR search	Automatic Number Plate Recognition (LPR/ANPR).
TimeCompressor	Object Tracker, Neural Tracker, built-in detection tool, or VMD.
Tag&Track Pro	Object Tracker, Neural Tracker, built-in detection tool, or VMD.
Object tracking	Any
Autozoom	Any

Attention!

If a camera uses several sources of metadata, the required source is selected automatically, except for MomentQuest. To perform facial/license number searches, only metadata from corresponding detection tools is used.

By default, metadata files are stored in Server's object trajectory database: C:\Program Files\AxxonSoft\AxxonNext\Metadata\vmdata_db\VMData_DB.0\vmdata_schema; if necessary, you can place them on any available network storage (see [Configuring storage of the system log and metadata](#)).

7.4.3 General information on Neural Analytics

The Axxon Next VMS offers AI analytics based on neural networks. These AI tools include:

1. **Neural Network Filter for Object Tracker** (see [Setting General Parameters](#)).
The neural network filter processes the results of the tracker and filters out false alarms on complex video images (foliage, glare, etc.).
2. **Neural Tracker** (see [Setting up Neural Tracker-based Scene Analytics](#)).
Neural Tracker detects only objects of a specified class. The Neural Tracker is more accurate than the regular one, and detects even static objects, but it requires more computing resources.
3. **Neural Counter** (see [Configuring a Neuralcounter](#)).
The Neural Counter relies on a neural network to work out the number of objects in the zone.
4. **Smoke and Fire Detection Tools based on Neural Network** (see [Configuring Smoke and Fire Detection Tools](#)).
A neural network detects fire and smoke in FoV.
5. **Posture Detection based on Neural Network** (see [Configure Pose Detection](#)).
AI-powered Posture Detection captures specific human poses that may represent a security threat.
6. **Equipment detection tool (PPE) based on Neural Network** (see [Configuring equipment detection tool \(PPE\)](#)).
For detection tool operation, you need a combination of two networks: segmenting and classifying.
7. **Person-based privacy masking** (see [Person-based privacy masking](#)).
A segmenting neural network is used to structure up an image of a human body.
8. **Water Level Detection** (see [Water Level Detection](#)).
The detection tool may use the neural network to detect water transparency and level.

Hardware requirements for neural analytics operation

7.4.3.1 Requirements to data collection for neural network training

To train your neural network, you have to collect (and submit to AxxonSoft) video recordings from your actual cameras with the same resolution, expected weather conditions and time of day as in your future application.

For example, if your neural network is intended to analyze outdoor video feeds, your footage must contain all range of weather conditions (sun, rain, snow, fog, etc.) in different times of day (daytime, twilight, night).

Extra requirements for video footage for each neural analytics tool are listed in the following table:

Tool	Requirements
Neural Filter	No less than 1000 frames containing objects of interest in given scene conditions, and the same amount of footage containing no objects (background footage).
Neural Tracker	3 to 5 minutes of video containing objects of interest in given scene conditions. The more the number and variability of the situations in the scene, the better.
Posture detection tools	No less than 100 different persons in given scene conditions. Attention! Different conditions mean, among others, different postures of an individual in scene (tilting, different limbs patterns, etc.).
Segmenting detector *	3 to 5 minutes of video containing objects of interest in given scene conditions.
Food recognition *	You need to submit no less than 80% of actual menu positions. Each position requires 20 to 40 images shot in different conditions.

Note

* Will be available in future versions of Axxon Next software.

The requirements may be changed or added to at any time.

7.4.4 Detection tools implementation on processors

Refer to the following table to check compatibility of detection tools and processors.

Detection tool	Windows x64			Linux AMD64		
	CPU	GPU	VPU	CPU	GPU	VPU
VMD	✓	✓	✗	✓	✗	✗
Service video detection tool	✓	✗	✗	✓	✗	✗
Service audio detection tool	✓	✗	✗	✓	✗	✗
Scene analytics detection tools	✓	✗	✗	✓	✗	✗
Neural Tracker	✓	✓	✓	✓	✓	✓
Neural network filter	✓	✓	✓	✓	✓	✓
Neuralcounter	✓	✓	✓	✓	✓	✓
Face detection tools	✓	✗	✗	✓	✗	✗
VT Automatic Number Plate Recognition	✓	✗	✗	✓	✗	✗
IV Automatic Number Plate Recognition	✓	✓	✗	✗	✗	✗

RR Automatic Number Plate Recognition	✓	✗	✗	✓	✗	✗
Smoke and Fire detection tools	✓	✓	✓	✓	✓	✓
Pose detection tools	✓	✓	✓	✗	✗	✗
Retail analytics detection tools	✓	✗	✗	✓	✗	✗
Water level detection tool	✓	✗	✗	✓	✗	✗
Personal protective equipment detection tool	✓	✓	✓	✗	✗	✗

7.4.5 Creating Detection Tools

To create a new detection tool for a camera:

1. Click **Create** link in the camera object tree.
All detection tools available are shown.

2. Select the one you need.

Note

Service Video and Audio Detection Tools are listed under **Additional**.

3. Click the **Apply** button.

Creation of the detection tool is now complete.

To create a detection tool for situation analysis, you must first create the corresponding object. It will be used as a basis for all situation analysis tools.

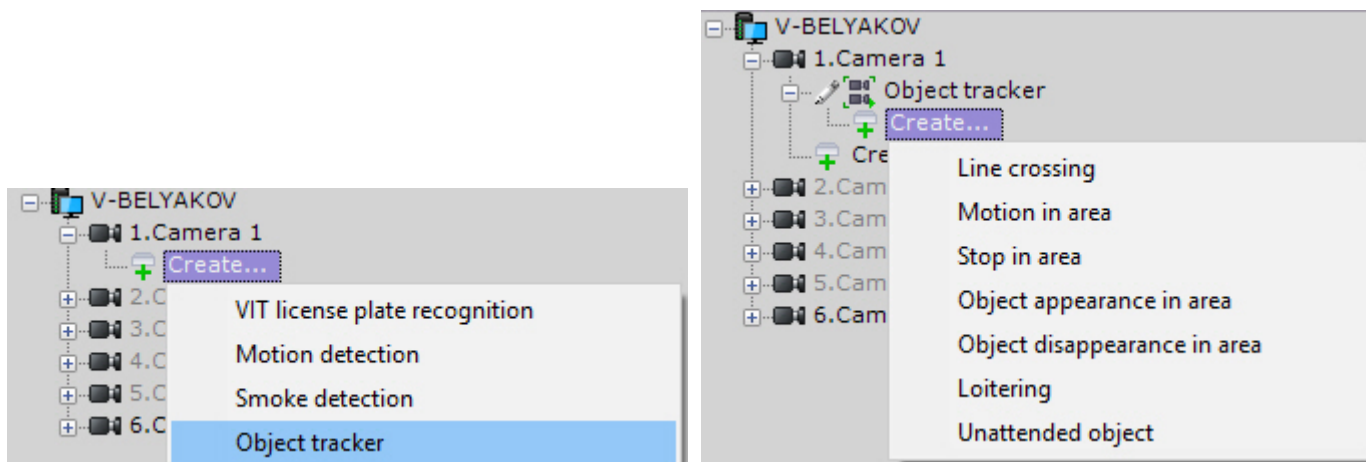

Furthermore, you create Scene Analytics based on VMD and the Motion Mask's metadata (see [Configuring VMD](#)).

Note

To enable Scene Analytics detection tools under a basic VMD, you have to activate the object tracking option in its settings.

Facial recognition tools are created in the same fashion: the basic **Face detection** object and its derivative detection tools.

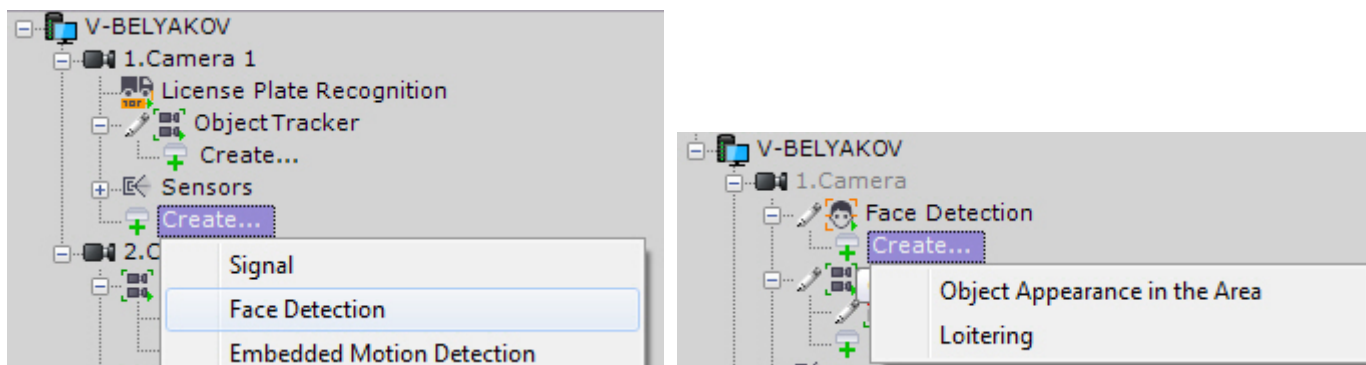

A posture detection tool is created under a parent **Pose Detection** object.

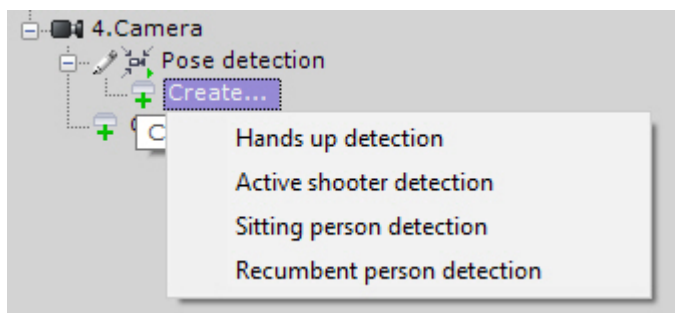

You can create a detection tool of the same type for a number of cameras. To do this:

1. Create the required tool on any video camera.
2. Click **Apply**.
3. Click the  button and select the cameras for which you want to create the same detection tool.

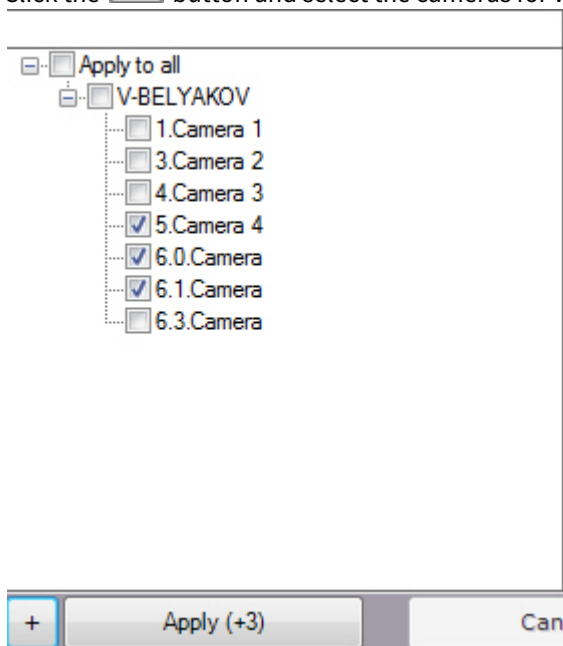

4. Click **Apply**.

To remove a detection tool, select the parent object and click **Remove**. To disable, select **No** in the **Enable** field.

Attention!

When you delete a detection tool all its metadata is also deleted. If you have deleted a detection tool, you cannot search its video with the forensic MomentQuest search.

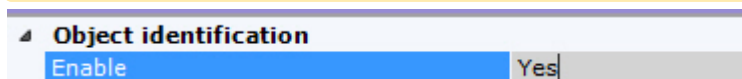

7.4.6 VMD (video motion detection)

7.4.6.1 Video requirements for VMD

Motion detection runs properly if video match the following requirements:

1. Camera requirements:
 - a. Resolution: Min. 320x240 pixels.
 - b. Frames per second: Min. 1 fps.

- c. Camera shaking must not cause image shifting of more than 1% of the frame size.
2. Lighting requirements:
 - a. Moderate lighting. Lighting that is too little (night) or too much (bright sunlight) may impact the quality of video analytics.
 - b. No major fluctuations in lighting levels.
3. Scene and camera angle requirements:
 - a. Moving objects must be visually separable from each other in the video.
 - b. The background must be primarily static and not undergo sudden changes.
 - c. Minimal obscuration of moving objects by static objects (columns, trees, etc.).
 - d. Reflective surfaces and harsh shadows from moving objects can affect the quality of analytics.
 - e. Long single-color objects may not be tracked properly.
4. Object requirements:
 - a. There is no noise on the video image and there are no artifacts caused by the compression algorithm.
 - b. The width and height of the objects in the image must be not less than 1% of the frame size (if resolution is over 1920 pixels) or 15 pixels for lower resolution.
 - c. The width and height of the objects in the image must not exceed 75% of the frame size.
 - d. The speed of objects in the frame must be at least 1 pixel per second.
 - e. In order to detect the object it is to be visible at not less than 8 frames.
 - f. Within two adjacent frames the object cannot move in the movement direction for the distance that is longer than its size. This condition is essential for correct calculation of the object's trajectory (track).

7.4.6.2 VMD features and specifications

The motion detection tool is triggered by motion in a video camera's field of view (FOV).

VMD metadata can be used for situation analysis in Scene Analytics (see [Setting up VMD-based Scene Analytics](#)).

7.4.6.3 Configuring VMD

To configure a VMD:

1. The Video Motion Detection tool can receive tracking metadata generated by the Motion Mask. The metadata are recorded into the database by default. To disable, select **No** in the **Record Object Tracking** (1).

Motion detection		
1	Record objects tracking	Yes
2	Video stream from camera	Low-quality video stream
	Other	
3	Alarm end delay	0
4	Camera position	Wall
5	Decode key frames	No
6	Decoder mode	CPU
7	Motion mask	Yes
8	Object tracking	No
9	Period	50
10	Sensitivity: Contrast	12
11	Sensitivity: Size	9

2. If a camera supports multistreaming, select the stream for which detection is needed (2). Selecting a low-quality video stream allows reducing the load on the Server.
3. In the **Alarm end delay** field, set a value in seconds for the time interval within which the detection tool remains triggered after motion stops (3). If motion is re-detected within this interval, no new event will be created.
4. To reduce false alarms rate from a fish-eye camera, you have to position it properly (4). For other devices, this parameter is not valid.
5. If necessary, enable the video stream grooming (5). In this case, only the I-frames will be decoded.

Important

This setting applies to all codecs. If a codec has keyframes and p-frames, the keyframe is decoded no more often than every 500 milliseconds. For the MJPEG codec, each frame is considered to be I frame.

This feature reduces the Server load but, as can be expected, negatively impacts the quality of detection.

This setting should be activated on "blind" Servers (Servers that do not display video) on which it is necessary to perform detection.

Important

Period and **Decode key frames** parameters **are** correlated.

If no local Clients are connected to a Server, the following rules are set for remote Clients:

- If the interval between consecutive I-frames exceeds the value specified in the **Period** field, the detection tool will process I-frames.
- If the I-frame frequency is lower than the value specified in the **Period** field, the detection tool will use the set value.

If at least one local Client connects to the Server, the detection tool is forced to use the set value. After the local Client disconnects, the indicated rules become valid again.

6. Select a processing resource for decoding video streams (**6**). When you select a GPU, a stand-alone graphics card takes priority (when decoding with NVidia NVDEC chips). If there's no appropriate GPU, the decoding will use the Intel Quick Sync Video technology. Otherwise, CPU resources will be used for decoding.
7. The VMD analyzes differences between the current frame and the static background (**10, 11**). Depending on a particular scene, we recommend the following sensitivity values for contrast and size:
 - a. Maximum sensitivity (street scenes where target objects are smaller):
 - i. **Sensitivity: contrast** = 16.
 - ii. **Sensitivity: size** = 10.
 - b. Medium sensitivity (default values for generic scenes):
 - i. **Sensitivity: contrast** = 12.
 - ii. **Sensitivity: size** = 9.
 - c. Low sensitivity (indoor cameras with an average distance to object of ca. 4m):
 - i. **Sensitivity: contrast** = 8.
 - ii. **Sensitivity: size** = 8.

For your convenience with setting sensitivity value, in the preview window you can see the Motion Mask. To disable it, select **No** in the **Motion Mask (7)** field.



If there is motion, but it does not exceed the threshold value (because of the detection sensitivity), the mask cells are colored green. If motion triggers VMD, the cells turn red.

8. To get tracked objects and their parameters (percentage of the FoV width/height, color) displayed in the Preview window, select **Yes** in the **Object Tracking** field (8).
9. In the **Period** field (9) enter the time in milliseconds. This the time before the next video frame is processed. This value should be in the range [0, 65535]. If the value is **0**, each frame is processed.
10. By default, VMD (video motion detection) covers the entire FoV. In the FoV, you can set privacy masks - closed areas, inside of which you want no detection.
Privacy masks are created similar to scene analysis configuration (see [Setting General Zones for Scene Analytics](#)).
11. Click **Apply**.

VMD configuration is now complete.

7.4.7 Service Video Detection Tools

7.4.7.1 Functions of Service Video Detection Tools

Name of a Detection Tool object	Detection description
Quality degradation	A detection tool which is triggered when the video image received from a video camera loses quality. For example, the detection tool may trigger upon excessive light, loss of focus, lens blocking, or sudden drop in scene illumination.
Scene change	A detection tool triggered by a change in the video image background indicating a change in the video camera's position in space
Image Noise Detection	A tool that triggers in the presence of video noise. For instance, triggering may occur upon low bit rate, or ripples on video.
Blurred Image Detection	A tool that detects blurred contours. For example, the detection tool may trigger when the image becomes blurry because of dirty lens.
Compression Artifacts Detection	Detects compression artifacts

7.4.7.2 Video Requirements for Service Video Detection Tools

For correct operation of the detection tools, video streams should match the following requirements:

1. Camera requirements:
 - a. Resolution: Min. 320x240 pixels.
 - b. Frames per second: Min. 1 fps.
 - c. Color: video analytics work with both black-and-white and color images.
 - d. Camera shaking must not cause image shifting of more than 1% of the frame size.
2. Lighting requirements:
 - a. Moderate lighting. Lighting that is too little (night) or too much (bright sunlight) may impact the quality of video analytics.
 - b. No major fluctuations in lighting levels.
3. Scene and camera angle requirements:
 - a. Moving objects must be visually separable from each other in the video.
 - b. The background must be primarily static and not undergo sudden changes.
 - c. Minimal obscuration of moving objects by static objects (columns, trees, etc.).
 - d. Reflective surfaces and harsh shadows from moving objects can affect the quality of analytics.
 - e. Long single-color objects may not be tracked properly.
4. Object requirements:
 - a. There is no noise on the video image and there are no artifacts caused by the compression algorithm.
 - b. The width and height of the objects in the image must be not less than 1% of the frame size (if resolution is over 1920 pixels) or 15 pixels for lower resolution.
 - c. The width and height of the objects in the image must not exceed 75% of the frame size.
 - d. The speed of objects in the frame must be at least 1 pixel per second.
 - e. In order to detect the object it is to be visible at not less than 8 frames.
 - f. Within two adjacent frames the object cannot move in the movement direction for the distance that is longer than its size. This condition is essential for correct calculation of the object's trajectory (track).

7.4.7.3 Set Parameters of Video Detection

All basic detection tools have a number of common settings.

1. If a camera supports multistreaming, select the stream for which detection is needed (**1**). Selecting a low-quality video stream allows reducing the load on the Server.

Scene change	
▼ Object identification	
Enable	Yes
Name	Scene change
▼ Object features	
1 Video stream from camera	Low-quality video stream
▼ Other	
2 Decode key frames	Yes
3 Decoder mode	CPU
4 Period	50

2. The default setting for all detection tools is Decode key frames (**2**). In this case, the frames are processed every 500 milliseconds or less often. To disable Decode key frames, select **No** in the appropriate field.

Important

This setting applies to all codecs. If a codec has keyframes and p-frames, the keyframe is decoded no more often than every 500 milliseconds. For the MJPEG codec, each frame is considered to be I frame.

This feature reduces the Server load but, as can be expected, negatively impacts the quality of detection.

This setting should be activated on "blind" Servers (Servers that do not display video) on which it is necessary to perform detection.

Important

Period and **Decode key frames** parameters **are** correlated.

If no local Clients are connected to a Server, the following rules are set for remote Clients:

- If the interval between consecutive I-frames exceeds the value specified in the **Period** field, the detection tool will process I-frames.
- If the I-frame frequency is lower than the value specified in the **Period** field, the detection tool will use the set value.

If at least one local Client connects to the Server, the detection tool is forced to use the set value. After the local Client disconnects, the indicated rules become valid again.

3. Select a processing resource for decoding video streams (**3**). When you select a GPU, a stand-alone graphics card takes priority (when decoding with NVidia NVDEC chips). If there's no appropriate GPU, the decoding will use the Intel Quick Sync Video technology. Otherwise, CPU resources will be used for decoding.
4. In the **Period** field (**4**) enter the time in milliseconds. This the time before the next video frame is processed. This value should be in the range [0, 65535]. If the value is **0**, each frame is processed.

To configure detection of noise, blurred image and compression artifacts, do as follows:

1. Max Processing Time is the maximum time for detection (**1**). If the bad image is not detected within the specified time, change the sensitivity settings.

Blurred image detection	
Object identification	
Enable	Yes
Name	Blurred image detection
Object features	
Video stream from camera	Low-quality video stream
Other	
Decode key frames	Yes
Decoder mode	CPU
1 Event duration to trigger detection (sec)	20
Period	50
2 Sensitivity	50

2. Sensitivity in standard units from 0 to 100 (**2**).

To save settings, click the **Apply** button.

7.4.8 Service Audio Detection Tools

7.4.8.1 Functions of Service Audio Detection Tools

The following detection tools enable analysis of the audio signal from a microphone.

Name of a Detection Tool object	Detection description
Audio loss	A detection tool which is triggered by the line break from the microphone to the Server (complete absence of sound)
Signal	A detection tool which is triggered by the reception of an audio signal from an audio device
Noise	A detection tool which is triggered by the appearance of noise

Attention!

Audio loss detection may operate incorrectly with video cameras emitting a background signal with a non-zero volume, even if the integrated microphone is physically disabled

7.4.8.2 Set Parameters of Audio Detection

To set audio detection tools, do the following:

1. In the **Period** field (1), enter a time value in milliseconds. This parameter sets the time interval after which a portion of the audio stream is analyzed. The value should be within the range [0, 65535]. If the value is 0, each portion of the audio stream is analyzed.

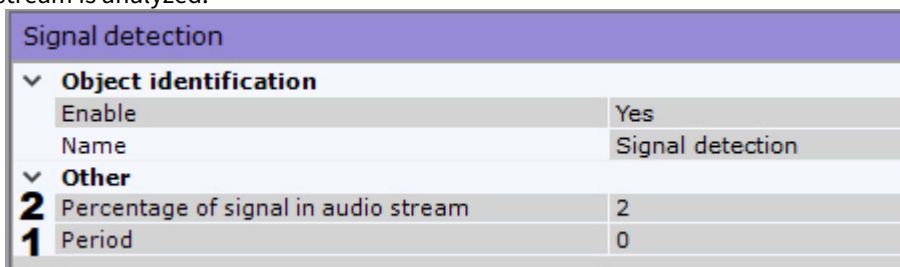

2. For the signal detection tool, set the threshold in percentage (2). The tool triggers on exceeding the threshold. Set the value by trial-and-error.
3. For the noise detection tool, set the threshold in percentage (3). The tool triggers on exceeding the threshold. Set the value by trial-and-error.



4. To save settings, click the **Apply** button.

7.4.9 Scene Analytics

7.4.9.1 Functions of Scene Analytics

The following detection tools enable analysis of the situation in a video camera's field of view.

Name of a Detection Tool object	Detection description
Motion in area	Motion in Area detection tool. Important! This tool is not triggered if an object enters the area (refer to Appearance in area).

Name of a Detection Tool object	Detection description
Stop in area	Non-activity detection tool. Important! This tool is not triggered if an object exits the area (refer to Disappearance in area).
Appearance in area	Entry into Area detection tool. Important! This tool does is not triggered if an object appears inside the area without crossing its perimeter (refer to Motion in Area).
Disappearance in area	Exit from Area detection tool. Important! This tool does is not triggered if an object disappears (or becomes idle) inside the area without crossing its perimeter (refer to Stopping in Area).
Loitering	a detection tool triggered by the lengthy presence of an object in an area of a video camera's field of view
Abandoned object	a detection tool triggered by the appearance of an abandoned object in an area of a video camera's field of view
Line crossing	a detection tool triggered by the trajectory of an object crossing a virtual line
Multiple objects	a detection tool is triggered when the number of objects within the designated area exceeds a predefined value
Move from area to area	a detection tool is triggered when an object moves from one pre-specified area to another within the scene

Attention!

To detect any motion within an area, you need to apply two detection tools:

- **Motion in Area** and
- **Appearance in area**.

Note

Nueral filter and Neural Tracker require Addon Neuro Pack to be installed.

7.4.9.2 Video requirements for scene analytics detection

7.4.9.2.1 Video requirements for object tracker-based scene analytics

For video analytics to work correctly, the following requirements must be met:

1. Camera requirements:
 - a. Resolution min. 640x360 pixels.

Attention!

Pixel resolutions over 800x600 are not recommended for this detection tool. Higher resolutions lead to increased RAM consumption and CPU load with no significant increase in tracker's performance.

- b. Frames per second: Min. 6 fps.
 - c. Color: video analytics work with both black-and-white and color images.

- d. Camera shaking must not cause image shifting of more than 1% of the frame size.
2. Lighting requirements:
 - a. Moderate lighting. Lighting that is too little (night) or too much (bright sunlight) may impact the quality of video analytics.
 - b. No major fluctuations in lighting levels.
 3. Scene and camera angle requirements:
 - a. Moving objects must be visually separable from each other in the video.
 - b. The background must be primarily static and not undergo sudden changes.
 - c. Minimal obscuration of moving objects by static objects (columns, trees, etc.).
 - d. Reflective surfaces and harsh shadows from moving objects can affect the quality of analytics.
 - e. Long single-color objects may not be tracked properly.
 4. Object requirements:
 - a. There is no noise on the video image and there are no artifacts caused by the compression algorithm.
 - b. The width or height of the objects in the image must be not less than 1% of the frame size (if resolution is over 1920 pixels) or 15 pixels for lower resolution.
 - c. The width or height of the objects in the image must not exceed 75% of the frame size.
 - d. The speed of objects in the frame must be at least 1 pixel per second.
 - e. In order to detect the object it is to be visible at not less than 8 frames.
 - f. Within two adjacent frames the object cannot move in the movement direction for the distance that is longer than its size. This condition is essential for correct calculation of the object's trajectory (track).

7.4.9.2.2 Video requirements for object tracker (with neural filter)-based scene analytics

For video analytics to work correctly, the following requirements must be met:

1. Camera requirements:
 - a. Resolution min. 640x360 pixels.
 - b. Frames per second: Min. 6 fps.
 - c. Color: video analytics work with both black-and-white and color images.
 - d. Camera shaking must not cause image shifting of more than 1% of the frame size.
2. Lighting requirements:
 - a. Moderate lighting. Lighting that is too little (night) or too much (bright sunlight) may impact the quality of video analytics.
 - b. No major fluctuations in lighting levels.
3. Scene and camera angle requirements:
 - a. Moving objects must be visually separable from each other in the video.
 - b. The background must be primarily static and not undergo sudden changes.
 - c. Minimal obscuration of moving objects by static objects (columns, trees, etc.).
 - d. Reflective surfaces and harsh shadows from moving objects can affect the quality of analytics.
 - e. Long single-color objects may not be tracked properly.
4. Object requirements:
 - a. There is no noise on the video image and there are no artifacts caused by the compression algorithm.
 - b. The width or height of the objects in the image must be not less than 1% of the frame size (if resolution is over 1920 pixels) or 15 pixels for lower resolution.
 - c. The width or height of the objects in the image must not exceed 75% of the frame size.
 - d. The speed of objects in the frame must be at least 1 pixel per second.
 - e. In order to detect the object it is to be visible at not less than 8 frames.
 - f. Within two adjacent frames the object cannot move in the movement direction for the distance that is longer than its size. This condition is essential for correct calculation of the object's trajectory (track).
5. [Camera requirements for neural filter operation.](#)

7.4.9.2.3 Video requirements for neural tracker-based scene analytics

For video analytics to work correctly, the following requirements must be met:

1. Camera requirements:
 - a. Resolution min. 300x300 pixels.
 - b. Frames per second: Min. 2 fps.
 - c. Color: video analytics work with color images.
 - d. Camera shaking must not cause image shifting of more than 1% of the frame size.
2. Lighting requirements:
 - a. Moderate lighting. Lighting that is too little (night) or too much (bright sunlight) may impact the quality of video analytics.
 - b. No major fluctuations in lighting levels.
3. Scene and camera angle requirements:
 - a. Moving objects must be visually separable from each other in the video.
 - b. The background must be primarily static and not undergo sudden changes.
 - c. Minimal obscuration of moving objects by static objects (columns, trees, etc.).
 - d. Reflective surfaces and harsh shadows from moving objects can affect the quality of analytics.
 - e. Long single-color objects may not be tracked properly.
4. Object requirements:
 - a. There is no noise on the video image and there are no artifacts caused by the compression algorithm.
 - b. The width or height of the objects in the image must be not less than 1% of the frame size (if resolution is over 1920 pixels) or 15 pixels for lower resolution.
 - c. The width or height of the objects in the image must not exceed 75% of the frame size.
 - d. The speed of objects in the frame must be at least 1 pixel per second.
 - e. In order to detect the object it is to be visible at not less than 8 frames.
 - f. Within two adjacent frames the object cannot move in the movement direction for the distance that is longer than its size. This condition is essential for correct calculation of the object's trajectory (track).
5. [Camera requirements for neural tracker operation.](#)

7.4.9.2.4 Video requirements for VMD-based scene analytics

For video analytics to work correctly, the following requirements must be met:

1. Camera requirements:
 - a. Resolution min. 640x360.
 - b. Frames per second: Min. 6 fps
 - c. Color: video analytics work with both black-and-white and color images.
 - d. Camera shaking must not cause image shifting of more than 1% of the frame size.
2. Lighting requirements:
 - a. Moderate lighting. Lighting that is too little (night) or too much (bright sunlight) may impact the quality of video analytics.
 - b. No major fluctuations in lighting levels.
3. Scene and camera angle requirements:
 - a. Moving objects must be visually separable from each other in the video.
 - b. The background must be primarily static and not undergo sudden changes.
 - c. Minimal obscuration of moving objects by static objects (columns, trees, etc.).
 - d. Reflective surfaces and harsh shadows from moving objects can affect the quality of analytics.
 - e. Long single-color objects may not be tracked properly.
4. Object requirements:
 - a. There is no noise on the video image and there are no artifacts caused by the compression algorithm.
 - b. The width or height of the objects in the image must be not less than 1% of the frame size (if resolution is over 1920 pixels) or 15 pixels for lower resolution.
 - c. The width or height of the objects in the image must not exceed 75% of the frame size.
 - d. The speed of objects in the frame must be at least 1 pixel per second.
 - e. In order to detect the object it is to be visible at not less than 8 frames.
 - f. Within two adjacent frames the object cannot move in the movement direction for the distance that is longer than its size. This condition is essential for correct calculation of the object's trajectory (track).

7.4.9.3 Camera requirements for neural filter operation

To operate the neural filter, a camera must match the following requirements:

1. Use color cameras. Monochrome image may noticeably decrease the detection quality.
2. Video resolution is no less than 640x360.
3. Frame rate is no less than 6 FPS.
4. An object must occupy no less than 5% of the FoV width / height.
5. Objects must be visually separated from the background as well as from each other.

Attention!

We cannot guarantee normal operation of the neural filter with a fisheye camera.

7.4.9.4 Camera requirements for neural tracker operation

To operate the neural tracker, a camera must match the following requirements:

1. Minimum resolution is at least 640x360 pixels.
2. Frame rate must be no less than 8 FPS. To detect fast moving objects (running individuals, vehicles), you must set frame rate at 18 FPS or above.
3. Objects must be visually separated from the background as well as from each other.
4. Camera is mounted in no less than 3 meters above the ground, or on the ceiling, or pointed strictly downwards (for counting visitors with a line crossing detection tool).
5. An object must occupy no less than 5% of the FoV width / height.

Attention!

We cannot guarantee normal operation of the neural tracker with a fisheye camera.

[Hardware requirements for neural analytics operation](#)

7.4.9.5 Camera requirements for abandoned objects detection

Make sure the following requirements for abandoned object detection are met:

1. Camera requirements:
 1. Resolution must be not less than 640x480 pixels.
 2. Color: analytics works both with color and monochromatic images.
 3. It is not allowed to the image shift be more than 1% from the frame size due to camera shake.
- Lighting requirements:
 1. Moderate lighting. The quality of analytics performance can be lower in case of low lighting (night) or over lighting (overexposure).
 2. There must be no dramatic changes in lighting.
- Scene and camera angle requirements:
 1. Background is mostly static and is not changed.
 2. Incorrect analytics performance can be caused by reflective surfaces.
 3. Abandoned objects are hidden by moving objects not longer than 10% of the time.
- Object images requirements:
 1. An abandoned object must be visible on the image.
 2. The digital noise and compression-related artifacts are minimal.

3. The width and height of the objects in the image must be not less than 1% of the frame size (if resolution is over 1920 pixels) or 15 pixels for lower resolution.
4. The width and height of the objects in the image must not exceed 25% of the frame size.

If these conditions are in place, the Abandoned Object detection tool is guaranteed to:

- Detect 92 items out of 100
- Keep false positives to 20 out of 100.

7.4.9.6 Configuring Scene Analytics Detection Tools

7.4.9.6.1 General information on Scene Analytics

Axxon Next uses two different trackers for moving objects detection and metadata calculation:

1. **Object Tracker** is a primary tool.
2. **Neural Tracker** is essentially the same but operates through neural networks. The neural one is more accurate and detects even static objects, but it requires more computing resources.

The Scene Analytics detection tools work with both trackers.

Attention!

The abandoned objects detection tool works only with the primary tracker.

When created, both **Object Tracker** and **Neural Tracker** objects are enabled by default. Tracked objects' parameters (relative width and height, color) are displayed in the camera window.

Note

Up to 25 objects can be tracked at the same time.



7.4.9.6.2 Setting up Tracker-based Scene Analytics

7.4.9.6.2.1 Setting General Parameters

Some parameters can be bulk configured for Situation Analysis detection tools. To configure them, do as follows:

1. Select the **Object Tracker** object.

Object tracker	
▼ Object identification	
Enable	Yes
Name	Object tracker
▼ Object features	
1 Record objects tracking	✓ Yes
2 Video stream from camera	Low-quality video stream
▼ Other	
Abandoned object detection	No
Abandoned object detection sensitivity	9
Alarm on object's max. idle time in area	60
3 Auto sensitivity	Yes
4 Camera position	Wall
5 Decoder mode	CPU
Long-time abandoned object detection	No
Max. object height	100
Max. object width	100
Min. object height	2
Min. object width	2
6 Motion detection sensitivity	25
▼ Advanced detection settings	
7 Antishaker	No
8 Frame size change	1280
Leveling rod height	20
Object calibration	No
9 Time of object in DB	3

2. By default, video stream's metadata are recorded in the database. You can disable it by selecting **No** in the **Record object tracking** list (1).

Attention!

Video decompression and analysis are used to obtain metadata, which causes high Server load and limits the number of video cameras that can be used on it.

3. If a video camera supports multistreaming, select the stream for which detection is needed (2). Selecting a low-quality video stream allows reducing the load on the Server.

Attention!

To display object trajectories properly, make sure that all video streams from multi-streaming camera have the same aspect ratio settings.

4. If you require automatic adjustment of the sensitivity of scene analytic detection tools, in the **Auto Sensitivity** list, select **Yes** (3).

Note

Enabling this option is recommended if the lighting fluctuates significantly in the course of the video camera's operation (for example, in outdoor conditions)

5. To reduce false alarms rate from a fish-eye camera, you have to position it properly (4). For other devices, this parameter is not valid.
6. Select a processing resource for decoding video streams (5). When you select a GPU, a stand-alone graphics card takes priority (when decoding with NVidia NVDEC chips). If there's no appropriate GPU, the decoding will use the Intel Quick Sync Video technology. Otherwise, CPU resources will be used for decoding.

7. In the **Motion detection sensitivity** field (6), set the sensitivity for motion detection tools, on a scale of 1 to 100.
8. To correct for camera shake, set **Antishaker** to **Yes** (7). This setting is recommended only for cameras that show clear signs of shaking-related image degradation.
9. Analyzed framed are scaled down to a specified resolution (8, 1280 pixels on the longer side). This is how it works:
 - a. If the longer side of the source image exceeds the value specified in the **Frame size change** field, it is divided by two.
 - b. If the resulting resolution falls below the specified value, it is used further.
 - c. If the resulting resolution still exceeds the specified limit, it is divided by two, etc.

Note

For example, the source image resolution is 2048 * 1536, and the limit is set to **1000**.

In this case, the source resolution will be divided two times (down to 512 * 384): after the first division, the number of pixels on the longer side exceeds the limit (1024 > 1000).

10. Enter the time interval in seconds, during which object's properties will be stored in the **Time of Object in DB** field (9). If the object leaves and enters the FoV within the specified time, it will be identified as one and the same object (same ID).
11. If necessary, configure the neural network filter. The neural network filter processes the results of the tracker and filters out false alarms on complex video images (foliage, glare, etc.).
 - a. Enable the filter by selecting **Yes** (1).

<div style="background-color: #f2f2f2; padding: 2px;"> v Neural network filter </div>	
1	Enable filter ↗ Yes
2	Hardware for moving objects filter GPU0
	Hardware for unattended objects filter GPU0
3	Moving objects filter file ↗ D:/human_car.ann
	Unattended objects filter file

- b. Select the processor for the neural network — CPU, one of GPUs or a [IntelNCS](#) (2).

Attention!

It may take several minutes to launch the algorithm on an NVIDIA GPU after you apply the settings.

- c. Select a neural network (3). To access a neural network, contact technical support. If no neural network file is specified, or the settings are incorrect, no filtering will occur.

Attention!

A neural network filter can be used either only for analyzing moving objects, or only for analyzing abandoned objects. You cannot operate two neural networks simultaneously.

12. Click the **Apply** button.

The general parameters of the situation analysis detection tools are now set.

Setting General Zones for Scene Analytics

By default, the entire FoV is a scene analytics zone. If you need to exclude parts of the scene prone to false alarms from detection (leaves, water, etc.), you should set privacy masks - zone with scene analytics and metadata generation disabled

To do so, follow the steps:

1. Select the **Object Tracker** object and click the  button.
2. In the FoV, set the nodes of the closed area, in order, inside of which you want no detection.





Note

When the area is being constructed, the nodes are connected by a two-color dotted line which outlines the area's borders.

Note

For your convenience, you can click the  button and configure the mask on a still frame / snapshot. To undo, click this button again.

Action	Result
Click in the viewing tile	Creates a new area node
Right-click on a created node	Deletes the area node
Position the cursor on a node and hold down the left mouse button while you move the mouse	Moves the area node
Click the  button.	Deletes the area

Once the area is closed, you will see the  buttons on the borderlines. If you click them, a new node is added. This allows you to be more flexible with zoning.

3. Set the required masking areas.
4. Click the **Apply** button.

You have successfully created the detection zone.

Note

These settings will apply for all situation analysis detection tools on the selected camera.

Set the Minimum and Maximum Object Size for Detection

You can set the minimum and maximum object size for detection by specifying numerical values or reference areas on screen. Objects of all sizes beyond the set values will not trigger detection.

To specify the size, do as follows:

1. Select the **Object Tracker** object.
2. In the **Max. Object height** and **Max. Object width** fields (1), enter the maximum height and width of a detectable object as a percent of the FoV height. The values should be in the range [0,05; 100].

1	Max. Object Height	100
	Max. Object Width	100
2	Min. Object Height	2
	Min. Object Width	2

Attention!

If you activate the **Object Calibration** parameter in tracker settings, please note that in this case min/max size of objects is specified in decimeters, not in FoV percentage (see [Configure Perspective](#)).

3. In the **Min. Object height** and **Min. Object width** fields (2), enter the minimum height and width of a detectable object as a percent of the FoV height. The values should be in the range [0,05; 100].
4. Click the **Apply** button.

To set the reference area on screen, do as follows:

1. Select the **Object Tracker** object.
2. Click the **Min**  button and set the minimum size of a detectable object. You can do so by dragging and dropping the nodes of the reference area.

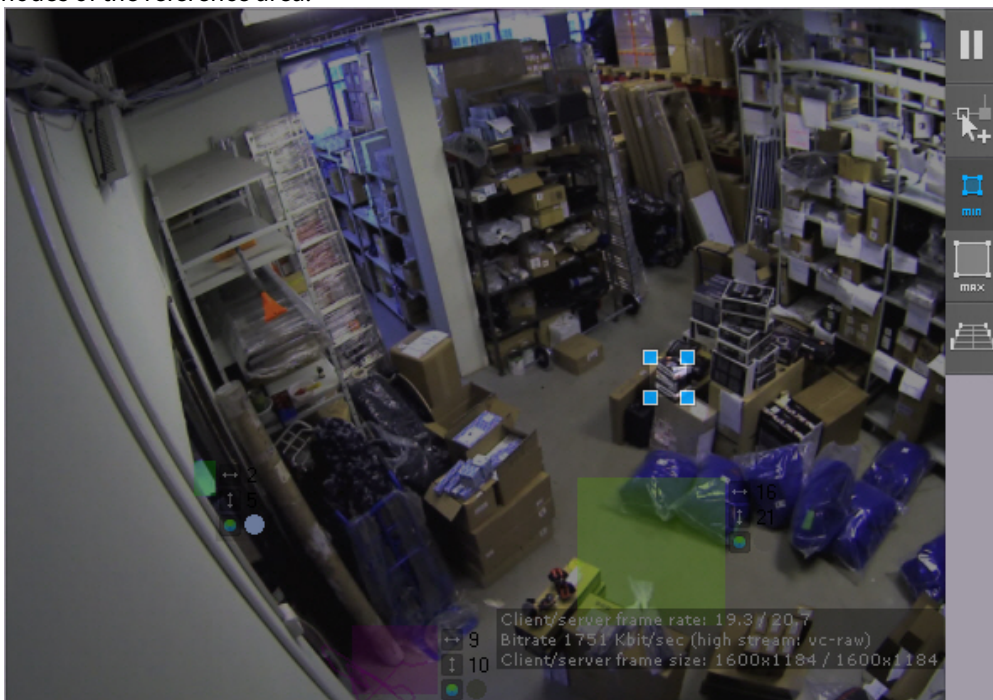

Note

For your convenience, you can click the  button and configure the mask on a still frame / snapshot. To undo, click this button again.

3. Click the **Max**  button and set the maximum size of a detectable object.

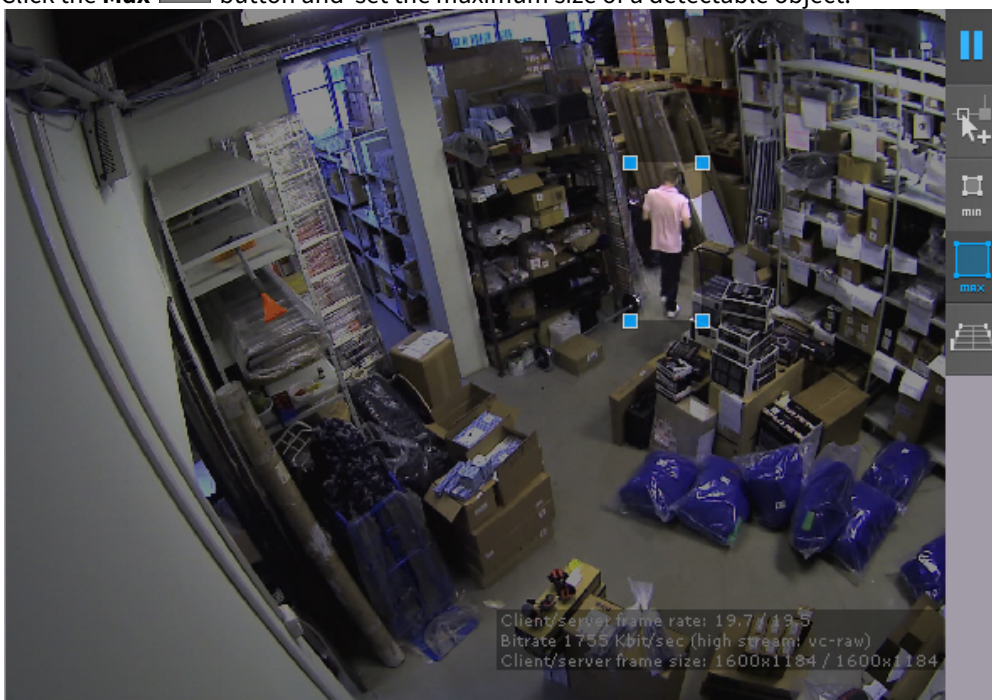

Note

By default, the maximum size is the whole size of FoV, so the nodes are located in the corners.

4. Click the **Apply** button.

You have successfully set the minimum and maximum object size for detection.

Note

These settings will apply for all situation analysis detection tools on the selected camera.

Configure Perspective

The Perspective enhances detection tools performance and helps evaluate real sizes of objects based on simplified calibration system.

To configure the perspective, do the following:

1. Select the **Object Tracker** object and click the  button.
2. Set the size of the same object in different areas of the field of view. To create a calibration length, left-click within the video image in the viewing tile and add two anchor points. Set at least three calibration lengths. You can resize the length

by stretching its anchor points . You can move it on screen by **dragging and dropping**.



Note

For your convenience, you can click the  button and configure the mask on a still frame / snapshot. To undo, click this button again.

Note

To delete it, click the  button.

3. Select **Yes** in the **Object Calibration** option (1).

Advanced detection settings	
Antishaker	No
Frame size change	1280
2 Leveling rod height	20
1 Object calibration	No
Time of object in DB	3

4. Enter the height in decimeters of the object you want to find in the **Leveling Rod Height** field (2).

Attention!

Objects smaller than the specified value will not be detected.

5. Click the **Apply** button.

Perspective is now configured.

Note

These settings will apply for all situation analysis detection tools on the selected camera.

Recommendations on configuring Object Tracker

To avoid false positives of Scene Analytics detection tools, please follow the recommendations here:

1. Configure the **Tracker object** object iteratively and check operation quality in each iteration.
2. The parameters that affect operation quality most are: **Minimum size**, **Maximum size** (see [Set the Minimum and Maximum Object Size for Detection](#)), and **Sensitivity** (see [Setting General Parameters](#)).
3. It is recommended to use **Auto sensitivity** mode to ensure quality of the Tracker operation in changing lighting conditions.
4. If lighting is stable, it could be reasonable to adjust the **Sensitivity** value manually. Set **Sensitivity** value about 35 to detect objects with low contrast or about 15 to detect contrast object.
5. Minimum size is to be selected so that it is a little less than typical object size on the image.
6. Maximum size is to be selected so that it is a little greater than typical object size on the image, considering that the object can be joined with its shadow.
7. Lowering the **Time of Object in DB** allows excluding triggering of false static objects, while setting it to a higher value could allow not breaking off alarms for overlapping or temporarily disappearing objects in some cases.

Configuring the Detection Zone

For each type of situation analysis detection tool you can set a detection zone.

After creating a detection tool, its rectangular detection zone is displayed in a bright color. If you have set privacy masks, they are grayed out (see [Setting General Zones for Scene Analytics](#)).



Configuration of the detection zone is carried out in the same way as for general zones for scene analysis (see [Setting General Zones for Scene Analytics](#)).

Setting up objects to be detected (target objects)

You can set parameters describing target objects' geometry and/or behaviour for each type of Scene Analytics tool.

To configure settings for target objects, you must:

1. Select an appropriate Scene Analytics tool.

Other		
Maximum object height	100	1
Maximum object speed	500	2
Maximum object width	100	3
Minimum object height	0.1	4
Minimum object speed	1	5
Minimum object width	0.1	6
Number of alarm objects	10	
Object color		7
Object type	Any type	8

2. Set the maximum and minimum height of the target object as a percentage of the FoV height (**1, 4**).
3. Set the maximum and minimum speed of the target object as a percentage of the frame per second (**2, 5**).

Attention!

For better visual understanding of speed settings, proceed to setting values for searches in Archive (see [Configuring minimum and maximum object speed](#)).

Note

In Abandoned Object detection, these parameters are not used.

4. Set the maximum and minimum width of the target object as a percentage of the FoV width (**3, 6**).
5. Set a color (or color range) for the target object:
 - a. Select the relevant detection tool object and click  in the **Object Color** field. The Object Color dialog opens.

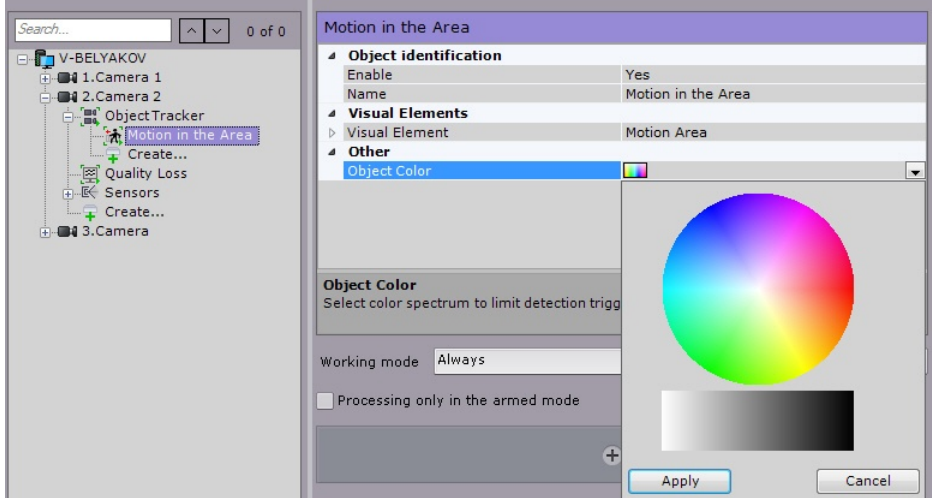

- b. You can set the color range with Drag&Drop on the RGB / black-and-white color palette.



Any click on the palette is interpreted as the beginning of a new range; the previous range will disappear.

Attention!

The Axxon Next's inner logic treats all objects as monochrome. The object color is averaged within the object's contour.

All objects of specified colors will be detected.

Attention!

If no colors are set, the detection tool triggers on objects of any color.

Note

To cancel a selected color, click on any palette, save changes, and click **Apply**.

6. Select the type of the target object that should trigger the detector (8).

Attention!

2 or more human objects moving along each other are treated by the system as a **Group**. If you select this type of object for tracking, single human motion, even if detected, will not cause alarms.

If you select the **Human** type, group motion will not cause alarms.

7. Click the **Apply** button.

The setting procedure for target objects is now complete.

7.4.9.6.2.2 Settings Specific to Cross Line Detection

After you create and select a line crossing detection tool, you can see a virtual "tripwire" line in the FoV.

To set up line crossing detection, do the following:

1. Set up a virtual line in FoV.

- a. Set the end points of the line .



Note

When the line is being constructed, the end points are connected by a two-color dotted line. The direction of the object's motion across the line is indicated by dotted arrows.

Action	Result
Position the cursor on an end point and, holding down the left mouse button, move the mouse	Moves the line end point
Position the cursor on the line, holding down the left mouse button, move the mouse	Moving the line

- b. By default, Line Crossing detection monitors object motion across the line in both directions. To suspend detection of motion in one direction, click the button  to that direction.

Attention!

At least one direction must be selected for detection

Note

An unmonitored direction of object motion is indicated by a dimmed arrow

2. If an object in FoV performs repetitive movements near the virtual line, it may cause excessive triggering of the detection tool. In this case, set an area within the object's track which must cross the line completely to trigger the tool. To do it, set the X and Y offset values as percentage of track width and height.

Line crossing	
Maximum object height	100
Maximum object speed	500
Maximum object width	100
Minimum object height	0.1
Minimum object speed	0
Minimum object width	0.1
Object class	Any
Object color	
Period	0
X-axis offset	15
Y-axis offset	10

Here's an example: the green triangle is the track of the object. If you specify X and Y offset values as 25%, the tool will be triggered only if the entire red triangle goes beyond the virtual line.

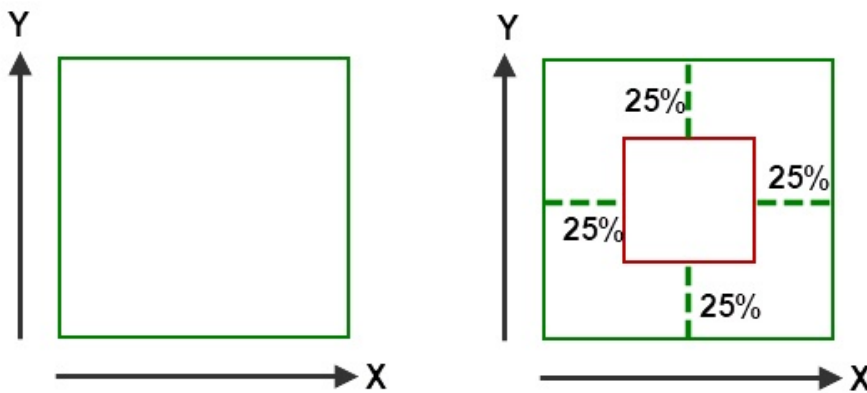

3. Click the **Apply** button.

7.4.9.6.2.3 Settings specific to Abandoned Object detection

To configure Abandoned Object detection, do as follows:

1. Select the **Object Tracker** object.

Object tracker	
Object identification	
Enable	Yes
Name	Object tracker
Object features	
Record objects tracking	<input checked="" type="checkbox"/> Yes
Video stream from camera	Low-quality video stream
Other	
1 Abandoned object detection	No
2 Abandoned object detection sensitivity	9
3 Alarm on object's max. idle time in area	60
Auto sensitivity	Yes
Camera position	Wall
Decoder mode	CPU
4 Long-time abandoned object detection	No
Max. object height	100
Max. object width	100
Min. object height	2
Min. object width	2
Motion detection sensitivity	25

2. In the **Abandoned Object Detection (1)**, select **Yes**.

- In the **Abandoned Object Detection Sensitivity** field (2), set the sensitivity for situational analytic tools for unattended objects. This value should be in the range [1, 100].

Note

This parameter depend on the lighting conditions and should be chosen empirically. It is recommended to start by setting the sensitivity at 20.

- In the **Alarm on Object's Max. Idle Time in the Area** field (3) specify the time in seconds. If the object remains idle for the specified time or longer, it will be considered unattended. This value should be in the range [15, 1800].

Note

This parameter is used only for tracking "lost items", i.e objects Unattended for longer time intervals

Note

It is recommended to start by setting the value of this parameter at 15.

- If you require using the unattended objects detection tool for longer time intervals, select **Yes** for the corresponding parameter (4).
- Under the **Object Tracker** object, create the **Abandoned Object** object (see [Creating Detection Tools](#)).
- Click the **Apply** button.

Abandoned object detection is now configured.

7.4.9.6.2.4 Settings Specific to Loitering Detection

When configuring the Loitering detection tool, you must set the maximum time an object can be in the analyzed area: when the maximum time is exceeded, the detection tool is triggered.

To set a maximum time, you must perform the following steps:

- In the Detection Tools list, highlight a **Loitering in area** object (1).

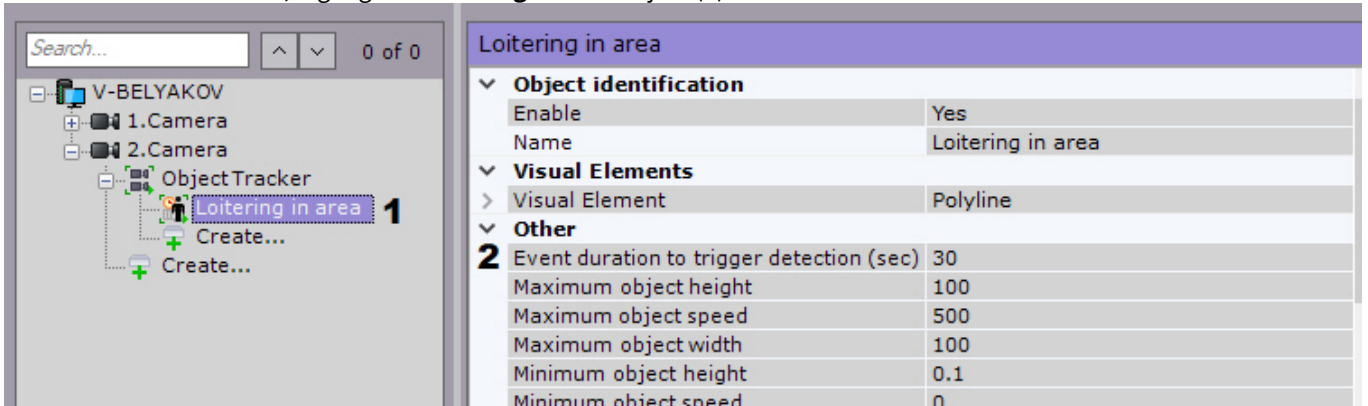

- In the **Event duration to trigger detection (sec)** field (2), enter the maximum object loitering time in seconds. This value should be in the range [0, 3600].
- Click the **Apply** button.

The maximum loitering time is now set.

7.4.9.6.2.5 Settings Specific to Multiple objects

When configuring the Multiple objects detection tool, you must set the maximum permissible number of objects within the zone; exceeding this number leads to triggering the tool.

To do it, follow the steps below:

1. In the list of detection tools, select the **Multiple objects (1)**.

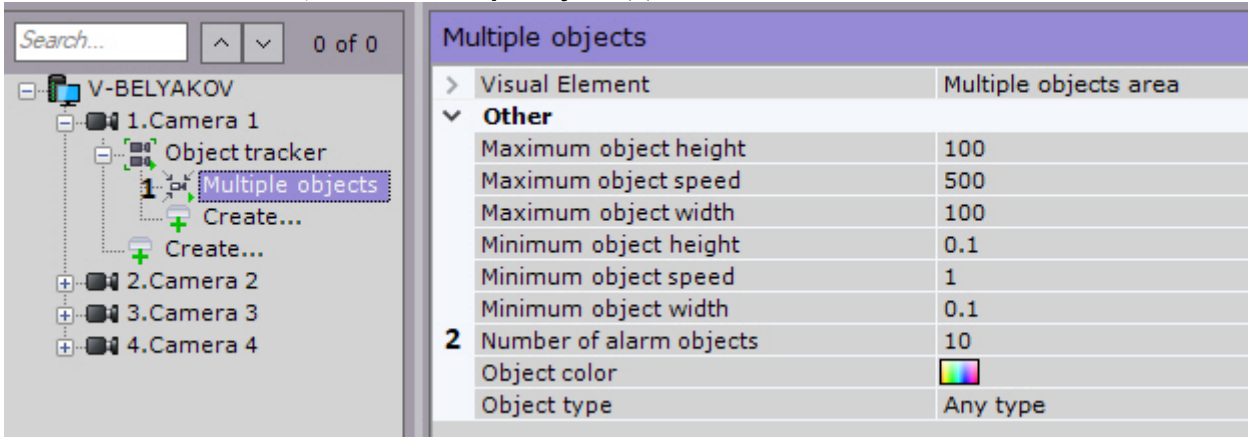

2. Enter a value into the **Number of Alarm Objects (2)** field .
3. Click **Apply**.

When the number of objects in zone maxes out, the **Start Time of Detection Tool Trigger** event is generated. When the number of object in zone drops down below the threshold value, the **End Time of Detection Tool Trigger** event is generated.

7.4.9.6.2.6 Settings Specific to Stop in area detection

The detection tool will trigger if an object stops and remains idle for a specified time period.

Note

The object doesn't have to be completely idle, minor jitter is permitted.

To set a specified time period, you must perform the following steps:

1. In the Detection Tools list, highlight a **Stop in area (1)**.

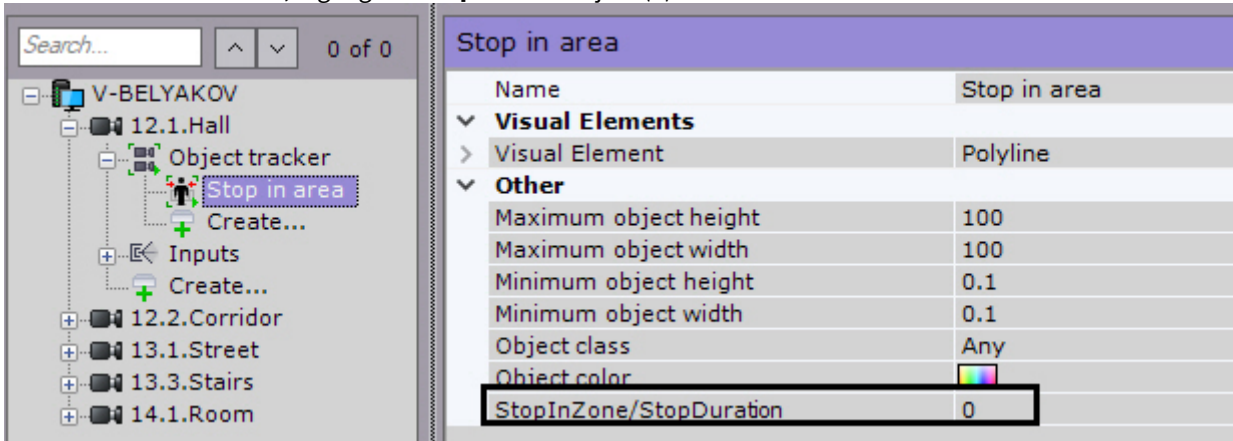

2. Set the idle period duration for triggering the tool. This value should fall into the range of [0, 3600].

Attention!



Set this parameter to a value lower than the **Time of Object in DB** in Object tracker settings (see [Setting General Parameters](#)).

3. Click the **Apply** button.

7.4.9.6.2.7 Settings Specific to Move from area to area detection

To set up a motion between areas detection tool, do the following:

1. Set the general parameters (see [Setting General Parameters](#)).

- Set two areas in FoV. The tool is triggered if any object moves from one area to another in any direction. By default, the areas are stacked on top of each other. To reshape an area, drag its anchor points . To move the entire area, left click and drag its border. To add anchor points, click .



- Click the **Apply** button.

7.4.9.6.3 Setting up Neural Tracker-based Scene Analytics

To configure the neural tracker, do the following:

- Select the **Neurotracker** object.

Neurotracker	
Object identification	
Enable	Yes
Name	Neurotracker
Object features	
1 Record objects tracking	<input checked="" type="checkbox"/> Yes
2 Video stream from camera	Low-quality video stream
Other	
3 Camera position	Wall
4 Decoder mode	CPU
5 Detection threshold	30
6 Minimum number of detection triggers	6
7 Neural network file	
8 Neurofilter	No
9 Neurofilter file	
10 Neurofilter mode	CPU
11 Neurotracker mode	CPU
12 Number of frames for analysis	6
Advanced detection settings	
13 Hide moving objects	No
14 Hide stationary objects	No
15 Track retention time	0.7

- By default, metadata are recorded into the database. To disable metadata recording, select **No (1)** from the **Record object tracking** list.
- If a camera supports multistreaming, select the stream to apply the detection tool to (**2**).

4. To reduce false alarms rate from a fish-eye camera, you have to position it properly **(3)**. For other devices, this parameter is not valid.
5. Select a processing resource for decoding video streams **(4)**. When you select a GPU, a stand-alone graphics card takes priority (when decoding with NVidia NVDEC chips). If there's no appropriate GPU, the decoding will use the Intel Quick Sync Video technology. Otherwise, CPU resources will be used for decoding.
6. Set the recognition threshold for objects in percent **(5)**. If the recognition probability falls below the specified value, the data will be ignored. The higher the value, the higher the accuracy – for the cost of sensitivity.
7. Specify the **Minimum number of detection triggers** for the neural tracker to display the object's trajectory **(6)**. The higher the value, the more is the time interval between the object's detection and display of its trajectory on screen. Low values may lead to false triggering.
8. Select the neural network file **(7)**.

Attention!

A trained neural network does a great job for a particular scene if you want to detect only objects of a certain type (e.g. person, cyclist, motorcyclist, etc.).

To train your neural network, contact AxxonSoft (see [Requirements to data collection for neural network training](#)).

Note

For correct neural network operation under Linux, place the corresponding file in the /opt/AxxonSoft/AxxonNext/ directory.

9. You can use the neural filter to sort out video recordings featuring selected objects and their trajectories. For example, the neural tracker detects all freight trucks, and the neural filter sorts out only video recordings that contain trucks with cargo door open. To set up a neural filter, do the following:
 - a. To use the neural filter, set **Yes** in the corresponding field **(8)**.
 - b. In the **Neurofilter file** field, select a neural network file **(9)**.
 - c. In the **Neurofilter mode** field, select a processor to be used for neural network computations **(10)**.
10. Select the processor for the neural network: the CPU or one of GPUs **(11)**.

Attention!

We recommend the GPU.

It may take several minutes to launch the algorithm on an NVIDIA GPU after you apply the settings.

11. Set the frame rate value for the neural network **(12)**. The other frames will be interpolated. The higher the value, the more accurate tracking, the higher the CPU load.

Attention!

6 FPS or more is recommended. For fast moving objects (running individuals, vehicles), you must set frame rate at 12 FPS or above.

12. If you don't need to detect moving objects, select **Yes** in the **Hide moving objects** field **(13)**. An object is treated as static if it does not change its position more than at 10% of its width or height during its track's lifetime.
13. If you don't need to detect static objects, select **Yes** in the **Hide stationary objects** field **(14)**. This parameter lowers the false alarm rate when detecting moving objects.
14. In the **Track retention time** field, set a time interval in seconds after which the tracking of a vehicle is considered lost **(15)**. This helps if objects in scene temporarily obscure each other. For example, a larger vehicle may completely block the smaller one from view.
15. By default, the entire FoV is a detection zone. If you need to narrow down the area to be analyzed, you can set one or several detection zones.

Note

The procedure of setting zones is identical to the primary tracker's (see [Setting General Zones for Scene Analytics](#)). The only difference is that the neural tracker's zones are processed while the primary tracker's are ignored.

16. Click **Apply**.
17. The next step is to create and configure the necessary detection tools. The configuration procedure is the same as for the primary tracker.

Attention!

To trigger a **Motion in Area** detection tool under a neural network tracker, an object must be displaced by at least 25% of its width or height in FoV.

Attention!

The abandoned objects detection tool works only with the primary tracker.

7.4.9.6.4 Setting up VMD-based Scene Analytics

Video requirements for VMD

To configure situational analysis based on video motion detection, do the following:

1. Request an updated license file from your AxxonSoft's rep.
2. Select a VMD object.

Motion detection		
Object features		
Record objects tracking	Yes	2
Other		
Camera position	Wall	3
Decode key frames	No	5
Motion mask	Yes	
Object tracking	No	1
Period	50	4
Sensitivity: Contrast	12	
Sensitivity: Size	9	

3. Select **Yes** in the **Object Tracking** field (1).
4. By default, metadata are not recorded into the database. To enable metadata recording, select **Yes** from the **Record objects Tracking** list (2).
5. To reduce false alarms rate from a fish-eye camera, you have to position it properly (3). For other devices, this parameter is not valid.
6. For a proper operation of VMD-based Scene Analytics, the detection tool must analyze a frame at least twice a second (refer to [Set Parameters of Video Detection](#) section for **Period** (4) and **Decode key frames** (5) parameters description).
7. Click the **Apply** button.
8. Next, you have to create and configure the necessary VMD-based detection tools. The configuration procedure is the same as for the primary tracker.

Attention!

VMD-generated metadata does not include object type and color information.

Attention!

The abandoned objects detection tool works only with the primary tracker.

7.4.10 Face detection tool

7.4.10.1 Functions of facial detection

The following types of Face Detection tools are available in Axxon Next:

1. Appearance in area – a detection tool is triggered by the appearance of an object and subsequent face capture in FoV.
2. Loitering in area – a detection tool triggered by the lengthy presence of an object and its face capture in FoV.
3. Face recognition evasion detection - triggers when anyone in scene wears dark glasses or covering masks, or uses other masking tricks.

The *Axxon Next* database stores all faces in binary form:

1. All captured facial images are vectorized* and stored in the **t_face_vector** table, and their corresponding capture events are stored in the **t_json_event** table.
2. Reference images (see [Lists of facial templates](#)) are stored in the **t_face_listed** table.

* Facial vector: mathematical representation of a facial image created upon face capture.

Note

These detection tools require Addon Face Recognition Pack to be installed (see [Installing DetectorPack add-ons](#)).

7.4.10.2 Camera requirements for facial detection

Face detection works properly if cameras are installed and set up as follows:

1. The frame rate must not be less than 12 fps and not less than 6 fps for face recognition at turnstiles.
2. The maximum angle of incidence should not exceed +/- 15 ° off the ground level.
3. Distance between pupils on the received photos of face must be not less than 32 pixels.
4. There should be minimum mutual overshadowing of the captured faces.
5. The faces should be evenly illuminated with a diffused light of at least 200 lux. Directional side lighting is not allowed.
6. The sharpness of the captured faces on the received photos must be over 64 grayscale. Deficient or exceeding illumination is not allowed.
7. There should be no back light and sharp gradients of light and shade.
8. The photos of the captured faces received from video cameras should be clear. Image blurring caused by motion is not allowed.

Note

The required distance between the camera and the face can be set using a lens with required focal length.

7.4.10.3 Configure Facial Recognition

To configure face detection tools, do as follows:

1. Set the general Facial Recognition parameters.
2. Configure a particular detection tool.

To configure shared Facial Recognition parameters, do as follows:

1. Select the **Facial Recognition** object.

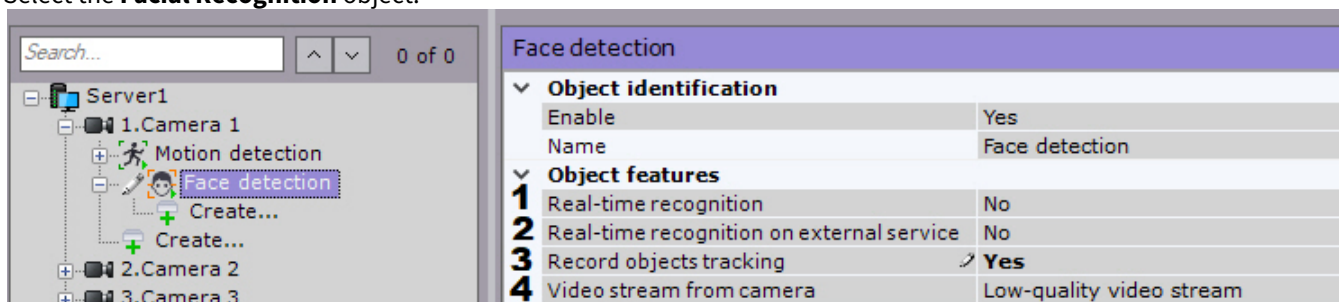

2. If you require using this detection tool for real-time facial recognition, set the corresponding parameter to **Yes (1)**.
3. If you want to use this facial recognition tool in real time in parallel with FaceCube Recognition Server (see [Configuring FaceCube integration](#)), set **Yes** for **Real-time recognition on external Service (4)**.
4. If you need to enable recording of metadata, select **Yes** from the **Record Objects tracking** list (3).
5. If a camera supports multistreaming, select the stream for which detection is needed (4). Selecting a low-quality video stream allows reducing the load on the Server.
6. If you need to save age and gender information for each recognized face, select **Yes** in the corresponding field (1, see [Facial recognition and search](#)).

Other	
1 Age and gender	No
2 Decoder mode	CPU
3 Face mask detection	No
4 Filter false alarms	Yes
5 Frame processing period (msec)	250
6 Frame size change	1920
Maximum face height	100
7 Maximum face width	100
Minimum face height	5
Minimum face width	5
8 Minimum threshold of face authenticity	90
9 Mode	CPU
10 Send face images	No
11 Track loss time	500
12 Use camera transform	No

7. Select a processing resource for decoding video streams (2). When you select a GPU, a stand-alone graphics card takes priority (when decoding with NVidia NVDEC chips). If there's no appropriate GPU, the decoding will use the Intel Quick Sync Video technology. Otherwise, CPU resources will be used for decoding.
8. If you plan to apply the masks detection tool, set **Yes** for the **Face mask detection** parameter (3, see [Configuring masks detection](#)).
9. In some cases, the detection tool may take other object for a face. To filter out non-facial objects, select **Yes** in the **False Detection Filtering** field while calculating the vector model of a face and its recording into the metadata DB (4). If the filtering is on, false results will appear in the detection feed but will be ignored during searches in Archive.
10. Set the time (in milliseconds) between face search operations in a video frame in the **Period of face search** field (5). Acceptable values range: [1, 10000]. Increasing this value decreases the Server load, but can result in some faces being missed.
11. Analyzed framed are scaled down to a specified resolution (6, 1280 pixels on the longer side). This is how it works:
 - a. If the longer side of the source image exceeds the value specified in the **Frame size change** field, it is divided by two.
 - b. If the resulting resolution falls below the specified value, it is used further.
 - c. If the resulting resolution still exceeds the specified limit, it is divided by two, etc.

Note

For example, the source image resolution is 2048 * 1536, and the limit is set to **1000**.

In this case, the source resolution will be divided two times (down to 512 * 384): after the first division, the number of pixels on the longer side exceeds the limit (1024 > 1000).

12. Specify the minimum and maximum sizes of detectable faces in % of the frame size (7).
13. In the **Minimum threshold of face authenticity** field, set the minimum level of face recognition accuracy for the creation of a track (8). You can set any value by trial-and-error; no less than 90 is recommended. The higher the value is, the fewer faces are detected, while recognition accuracy increases.
14. Select the processor for the face detection - CPU or NVIDIA GPU (9).

Attention!

It may take several minutes to launch the algorithm on an NVIDIA GPU after you apply the settings.

15. If you use FaceCube integration (see [Configuring FaceCube integration](#)), activate the **Send face image** parameter (10).
16. Enter the time in milliseconds after which the face track is considered to be lost in the **Track loss time** field (11). Acceptable values range: [1, 10000]. This parameter applies when a face moves in a frame and gets obscured by an obstacle for some time. If this time is less than the set value, the face will be recognized as the same.
17. When using wide angle dual lens XingYun devices, the detector will analyze two 180° spherical images by default (see [Configuring fisheye cameras](#)). This may decrease recognition quality. To de-warp the image before detection, select **Yes** for the **Use Camera Transform** parameter (12). This parameter works as well for other types of image transformation.
18. Select a rectangular area to be searched for faces in the preview window. To select the area, move the intersection points .

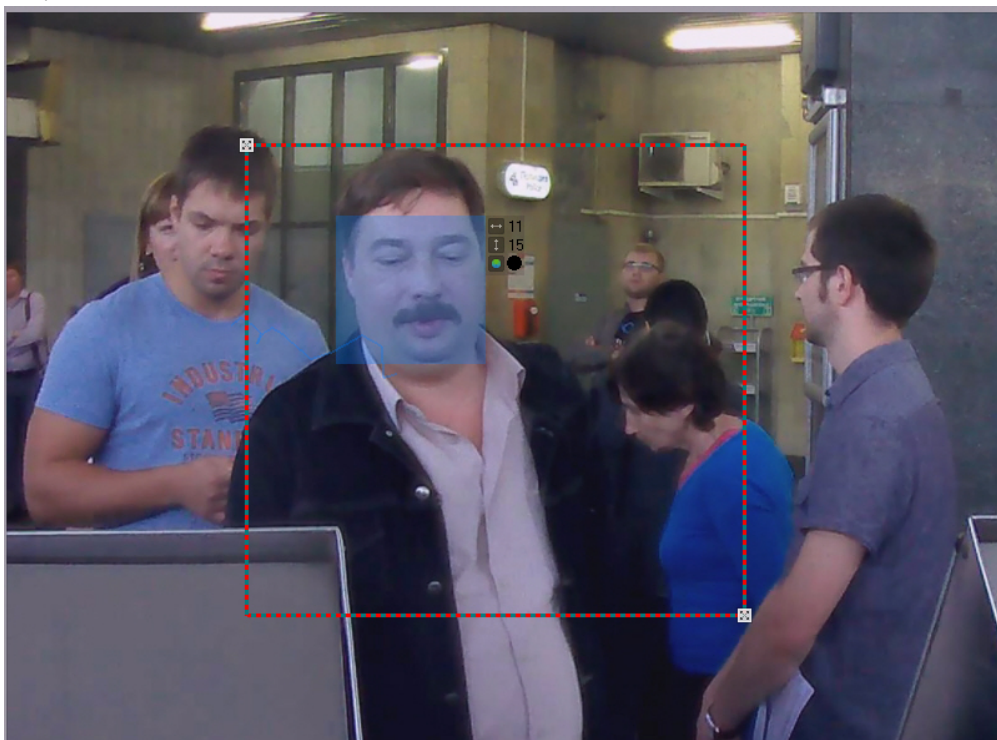

19. Click the **Apply** button.

Configuration of general parameters for Facial Recognition is now complete.

7.4.10.3.1 Setting up advanced facial detection tools

7.4.10.3.1.1 Configuring masks detection

To configure the masks detection tool, do the following:

1. Activate the **Face Mask Detection** parameter in facial recognition tool settings (see [Configure Facial Recognition](#)).

- In the **Number of Consecutive Mask Detections** field, set the minimum number of frames with the mask for triggering the tool.

Masks Detection

- Object identification**

Enable	Yes
Name	Masks Detection
- Other**

Full face masking	Not selected
Lower face part masking	Not selected
No mask	Presence
Other types of masks	Not selected
Period	0
- Advanced detection settings**

Number of consecutive mask detections	2
---------------------------------------	---

- Depending on your particular task, set other parameters' values according to the table.

Triggering event	Parameter Values		
	Lower face part masking	No mask	Full face masking
No mask of any kind	Absence	Presence	Absence
No medical mask	Absence	Presence	Presence
No balaclava	Presence	Presence	Absence
Any mask present	Presence	Absence	Presence
Medical mask present	Presence	Absence	Absence
Balaclava present	Absence	Absence	Presence

Note
The **Other Types of Masks** parameter is not supported in this software version.

- If required, you can set advanced parameters (see [Fine-tuning the facial recognition tool](#)).
- Click **Apply**.

7.4.10.3.1.2 Configuring appearance in area detection

To configure the detection tool:

1. Select an object.

Appearance in area	
▼ Visual Elements	
> Visual Element	Polyline
▼ Other	
Maximum object height	100
Maximum object speed	500
Maximum object width	100
Minimum object height	0.1
Minimum object width	0.1
Minimum speed	0
Object class	Any
Object color	
Name Detection object name.	

2. Configure parameters for the captured face (just as with detected objects, see [Setting up objects to be detected \(target objects\)](#)).

Attention!

Select the Object class: Any or Face.

Note

Face color is not detected during Facial recognition, so there are no color settings.

3. Set an area inside FoV for detection. This is similar to the situation analysis configuration (see [Configuring the Detection Zone](#)).
4. Click the **Apply** button.

7.4.10.3.1.3 Configuring loitering in area detection

To configure the detection tool:

1. Select an object.

Loitering in area detected	
> Visual Element	Polyline
▼ Other	
Loitering in area maximum time	30
Maximum object height	100
Maximum object speed	500
Maximum object width	100
Minimum object height	0.1
Minimum object speed	0
Minimum object width	0.1
Object class	Any
Object color	
Name Detection object name.	

2. Configure parameters for the captured face (just as with detected objects, see [Setting up objects to be detected \(target objects\)](#)).

Attention!

Select the Object class: Any or Face.

Note

Face color is not detected during Facial recognition, so there are no color settings.

3. Set the maximum time an object can stay in the zone. When the maximum time is exceeded, the detection tool is triggered. This value should be in the range [0, 3600].
4. Set an area inside FoV for detection. This is similar to the situation analysis configuration (see [Configuring the Detection Zone](#)).
5. Click the **Apply** button

7.4.10.3.2 Fine-tuning the facial recognition tool

Attention!

To fine tune this detection tool, you will require assistance from AxxonSoft tech support.

To fine-tune the detection tool, do as follows:

1. Select a recognition algorithm (1):

Advanced detection settings	
1	Face detection algorithm
2	False mask detections filtering
3	Minimum face masking threshold
4	Minimum face quality for face mask detection
5	Minimum face recognition quality
6	Minimum filtering threshold
7	Minimum filtering threshold for face mask detection

ALG1 is faster but less accurate while

ALG2 is more accurate but relatively slower.

2. Set up false mask detections filtering:
 - a. To apply filters, set **Yes** for the **False mask detections filtering** parameter (2).
 - b. Set the minimal percentage of probability which makes the additional algorithm identify a track as a masked face in the **Minimum filtering threshold for face mask detection** field (7). If the algorithm takes a decision that the track relates to a masked face with a probability value lower than the specified threshold, the track will be ignored. Set the value by trial-and-error, values over 30 are recommended.
3. Set the minimum threshold value for mask detection (3). Set a value by trial-and-error, values over 70 are recommended.
4. Set the minimum quality of a facial image for recognition with a mask (4, see [Configuring masks detection](#)). Set the value by trial-and-error, values over 30 are recommended.
5. Set the minimum quality of a facial image for recognition without a mask (5). Set the value by trial-and-error, values over 50 are recommended.
6. If you need to filter out false positives, set the minimum percentage of probability which makes the algorithm identify a track as a human face in the **Minimum filtering threshold** field (6, see [Configure Facial Recognition](#)). If the algorithm takes a decision that the track relates to a face with a probability value lower than the specified threshold, the track will be ignored. Set the value by trial-and-error, values over 50 are recommended.
7. Click the **Apply** button.

7.4.10.4 Configuring real-time facial recognition

You can program automatic responses to an identification of a recognized face against an external list (for example, of wanted persons).

To do it, follow the steps below:

1. Activate the **Real-time Recognition** parameter for the required detection tools (see [Configure Facial Recognition](#)).
2. Create one or more Lists of Persons. Add reference images of persons of interest to the lists (see [Lists of facial templates](#)).
3. Configure automatic responses to positive identification against the list.

7.4.10.4.1 Setting the automatic response to an identification of a recognized face against the list

To set an automatic response to an FR event, do as follows:

1. Create a macro (see [Create Macros](#)).
2. As a starting condition, select the **Face Recognition** event and the desired list (**1**, see [Configuring filters for event-driven macros](#)).

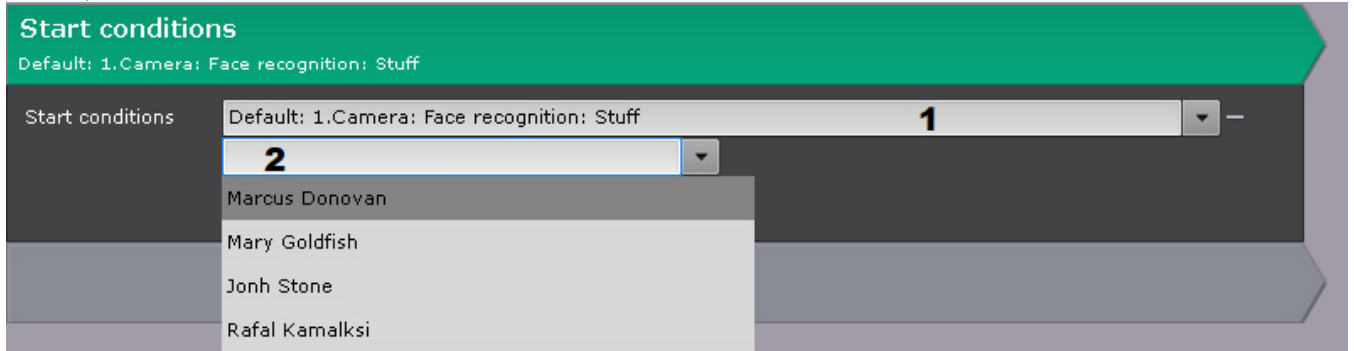

3. By default, the macro is triggered by recognition of any face from the list. If required, you can specify a particular person whose facial recognition will trigger the macro (**2**).

Note

To select another person, clear the **2** field and re-open the list.

4. Program an action or a sequence of actions to be performed in response to an identification of a recognized face against the designated list (see [Settings specific to actions](#)).
5. If the response involves initiating an alarm, you can configure the Dialog Board to filter **Alarm Initiated by Macro Command** events (see [Configure the Dialog Board](#)).

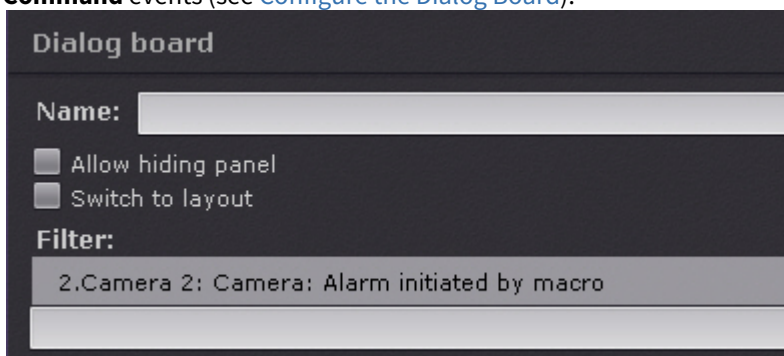

[Examples of macros used for working with face lists](#)

7.4.10.4.1.1 Examples of macros used for working with face lists

On this page:

- Alarm initiation
- Response to a recognition of a non-listed person
- Sending an e-mail
- Starting export

Alarm initiation

This macro can be used together with the Dialog Board (see [Configure the Dialog Board](#)).

If the Dialog Board is configured to display an alarm and linked with a video camera (see [Linking cells](#)), then when a face from the list is recognized, the following information will be displayed on the Dialog Board:

1. Reference photo from the face list.
2. An enlarged image of the recognized face in the frame.
3. The name of the recognized person, the comment in quotation marks, the name of the face list in square brackets, and the percentage of similarity with the reference face in parentheses (see [Lists of facial templates](#)).

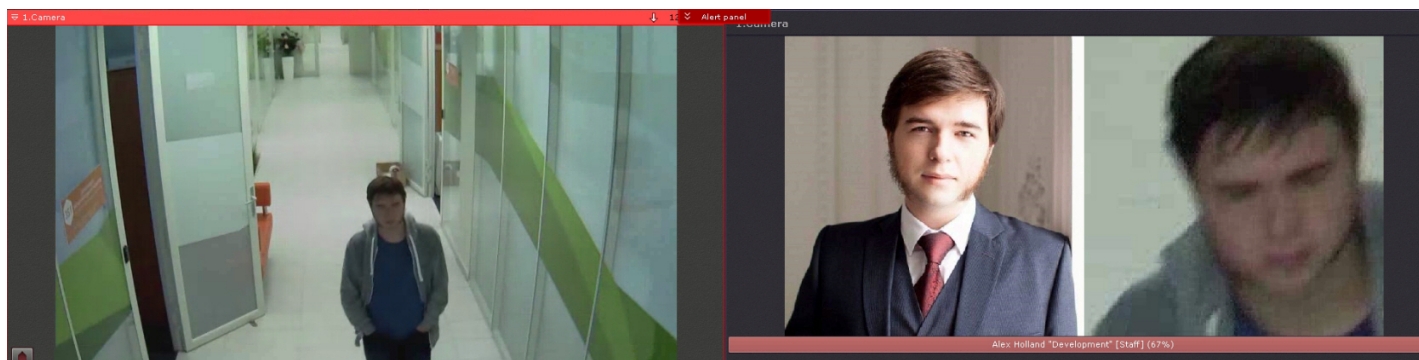

Response to a recognition of a non-listed person

Start conditions

Manual start

Start conditions -

Default: 8.Camera: Face detection: Triggering

+ Add event filter

Awaiting

5 seconds ✕

Timeout +

- 00:00:05

Start conditions -

Default: 8.Camera: Face recognition: Wanted

+ Add event filter

Execute if event occurred

+

Execute if no event occurred

Alarm initiation

Initiate if no active | Camera that initiated command execution ✕ +

Alarm: -

Initiate if no active

Camera -

Camera that initiated command execution

Record to: -

+

+

Sending an e-mail

The screenshot shows a configuration window with two main sections: 'Start conditions' and 'Send E-mail'.

Start conditions: A dropdown menu is set to 'Axxon: Face recognition: Staff'. Below it is an 'Add event filter' button with a plus icon.

Send E-mail: This section contains several fields:

- Email message:** A dropdown menu set to 'V-BELYAKOV/1.User e-mail'.
- To:** A text field containing 'mail@server.com'.
- Subject:** A text field containing 'Notification: Attention, automatic rule is triggered.'
- Message:** A large empty text area for the email body.
- Export agent:** A dropdown menu set to '1.Export agent'.
- Camera:** A dropdown menu set to 'Camera that initiated command execution'.
- Archive:** A dropdown menu that is currently empty.
- During:** A time interval field set to '00:00:00'.

If the e-mail is sent via the SMTP server (see [Configuring the E-mail Object](#)), then 3 files will be attached to the message:

- full frame at the moment of face recognition;
- reference photo from the face list;
- an enlarged image of the recognized face in the frame.

Starting export

As with the e-mail notifications, three files will be exported when you export an image for a facial recognition event i.e. when a match from Lists of Facial Templates is detected:

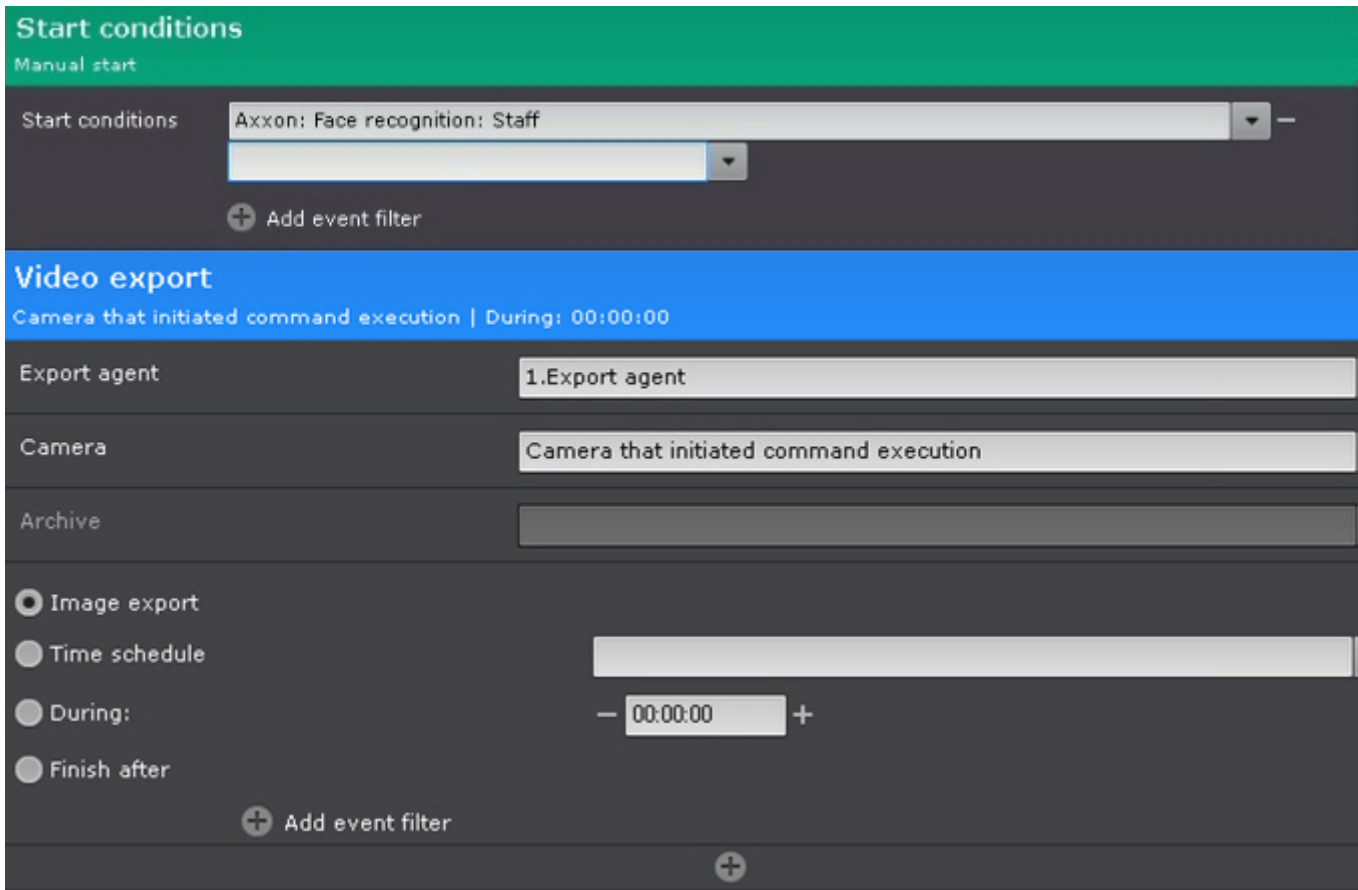

- Full frame at the moment of facial recognition;
- Reference photo from the List of Facial Templates.
- Close up shot of the target face captured in the scene.

7.4.10.4.2 Configuring FaceCube integration

Axxon Next supports the FaceCube facial recognition server (see <https://www.bio-cube.co.kr/vs-face>).

Please see the FaceCube integration workflows below:

1. Axxon Next captures and recognizes a face, then passes the facial image to the FaceCube facial recognition server.
2. FaceCube checks the facial image against the DB.
3. If a match is found, the Axxon Next VMS receives the results (see [Facial recognition and search](#)).

To configure FaceCube workflows, do as follows:

1. Configure the FaceCube facial recognition server and add Reference faces (see <https://www.bio-cube.co.kr/>).
2. Create a face list in Axxon Next and enter the address of the FaceCube facial recognition server into the **List Settings** field (see [Lists of facial templates](#)).

	Delete	Face lists	%	List settings
✎	×	Wanted	80	http://127.0.0.1:10111/FaceCubePlus
*				

3. Activate the **Real-time recognition on external Service** parameter and **Send face image** in the facial recognition settings (see [Configure Facial Recognition](#)).
4. Configure automatic responses to positive identification against the list (see [Setting the automatic response to an identification of a recognized face against the list](#)).

7.4.11 Face Detection and Temperature Control with Mobotix M16 TR cameras

7.4.11.1 Functional parameters of the Face Detection and Temperature Control

When working with Mobotix M16 TR cameras, the standard face detection algorithm (see [Functions of facial detection](#)) is used along with an additional option of temperature measurement.

For each recognized face, the following is performed:

1. Temperature measurement.
2. Display the measurement result next to the face bounding box.
3. Recording the temperature value into the system log along with the face recognition event (see [The System Log](#)).

You can as well set the system to launch a macro if temperature readings exceed the maximum permitted value (see [Specific parameters for triggering a face recognition macro](#)).

7.4.11.2 Camera requirements for face detection and temperature control

Face detection with temperature control works properly if cameras are installed and set up as follows:

1. At least 8 frames per second
2. Minimum resolution is at least 1280 x 960 pixels.
3. Indoor installation only.
4. To establish maximum measurement accuracy, avoid installing cameras near exits to street, in direct sunlight, and close to HVAC outlets.
5. Keep the distance from camera to the subject of measurement within the range of 1–2 meters.
6. For best accuracy, install the Electromagnetic Radiation Absorber (BB) at the same distance from camera as the subjects of measurement.
7. The maximum angle of incidence should not exceed +/- 15 ° off the ground level.
8. Distance between pupils on the received photos of face must be not less than 32 pixels.
9. There should be minimum mutual overshadowing of the captured faces.
10. The faces should be evenly illuminated with a diffused light of at least 200 lux. Directional side lighting is not allowed.
11. The sharpness of the captured faces on the received photos must be over 64 grayscale. Deficient or exceeding illumination is not allowed.
12. There should be no back light and sharp gradients of light and shade.
13. The photos of the captured faces received from video cameras should be clear. Image blurring caused by motion is not allowed.

Note

The required distance between the camera and the face can be set using a lens with required focal length.

7.4.11.3 Temperature screening protocol

For maximum measurement accuracy, please make sure that:

1. Subjects of measurement must have their body temperature normalized. To do this, please avoid their exposure to direct sunlight, incoming air flow from street or HVAC, and exclude any other factors that may cause momentary changes in body temperature.
2. The measurement area may contain only one individual.
3. No headgear, medical mask or glasses may be worn in the area.
4. The subject should dwell in the control area no less than 3 seconds, standing/sitting still, facing the camera.

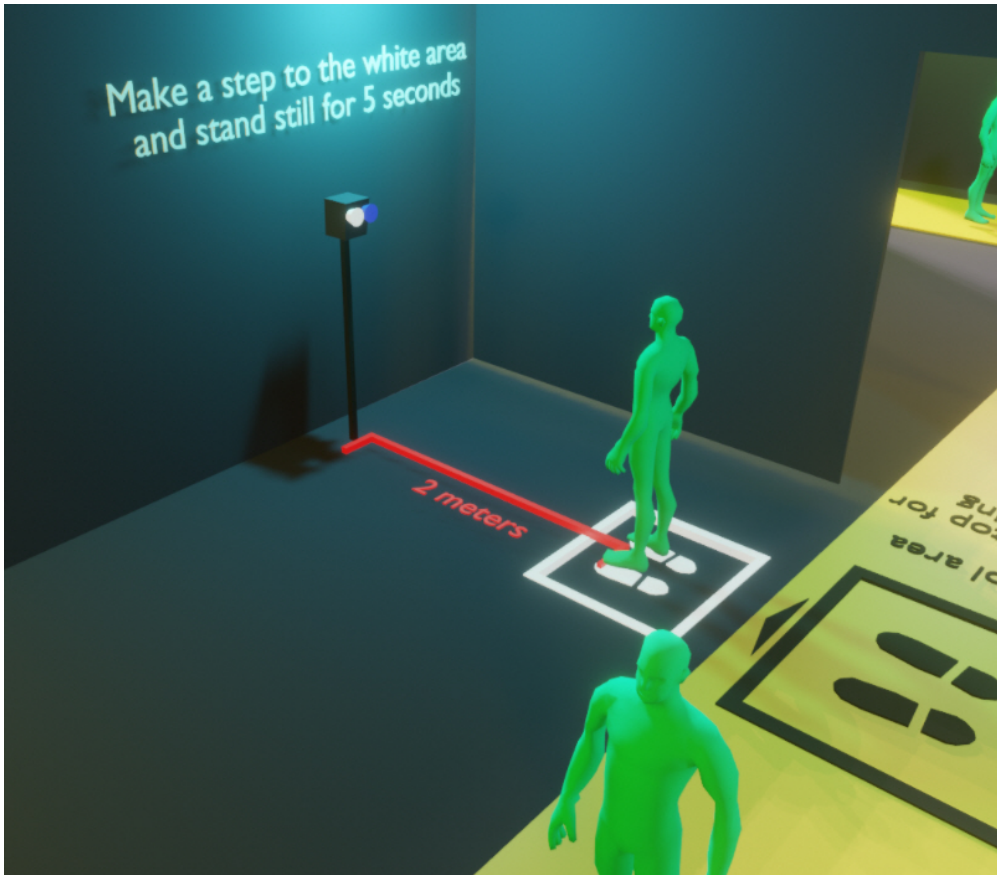

7.4.11.4 Pre-configuration of the Mobotix M16 TR camera

Attention!

Install MX-V5.2.6.7 (2020-06-16) or later firmware.

For detailed configuration via the web interface, refer to manufacturer's instructions.

Before starting Axxon Next, please configure the camera via the web interface:

1. Proceed to admin menu (1), and select **Temperatures** (2).

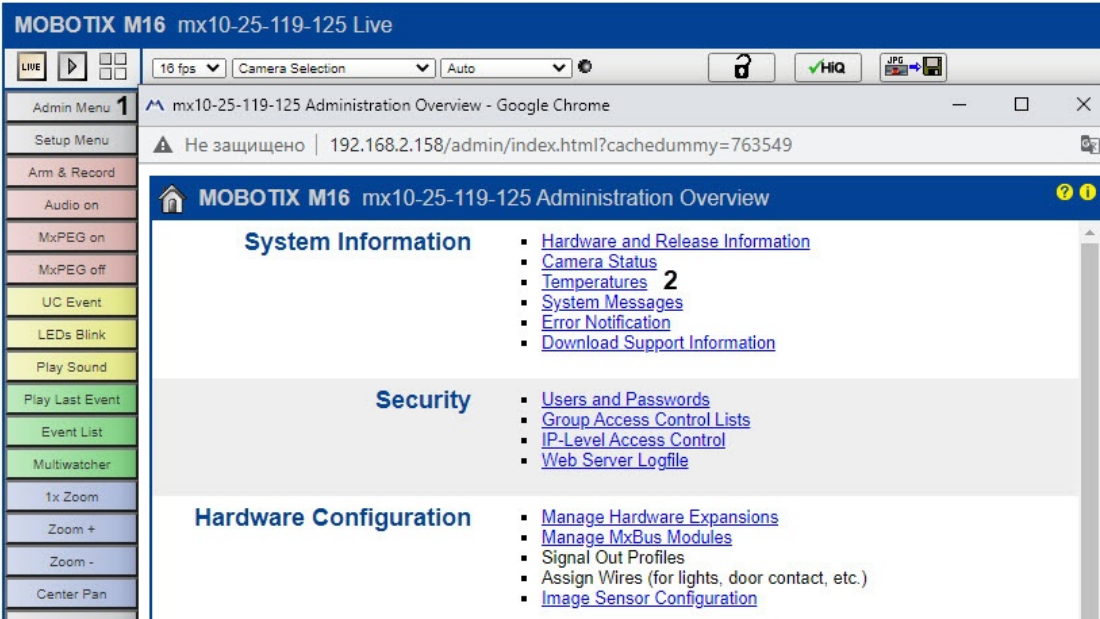

2. Measure environmental temperature.

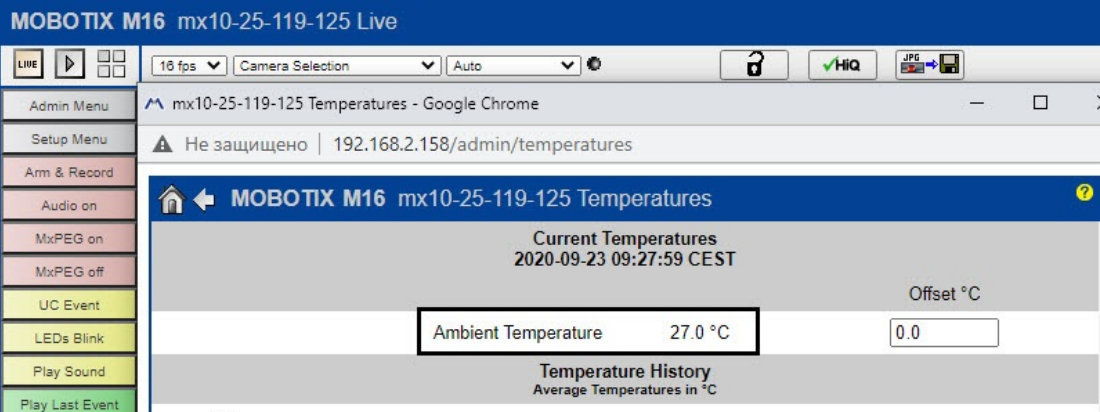

3. Select **Setup Menu** (1), and then **Thermal Sensor Settings** (2).

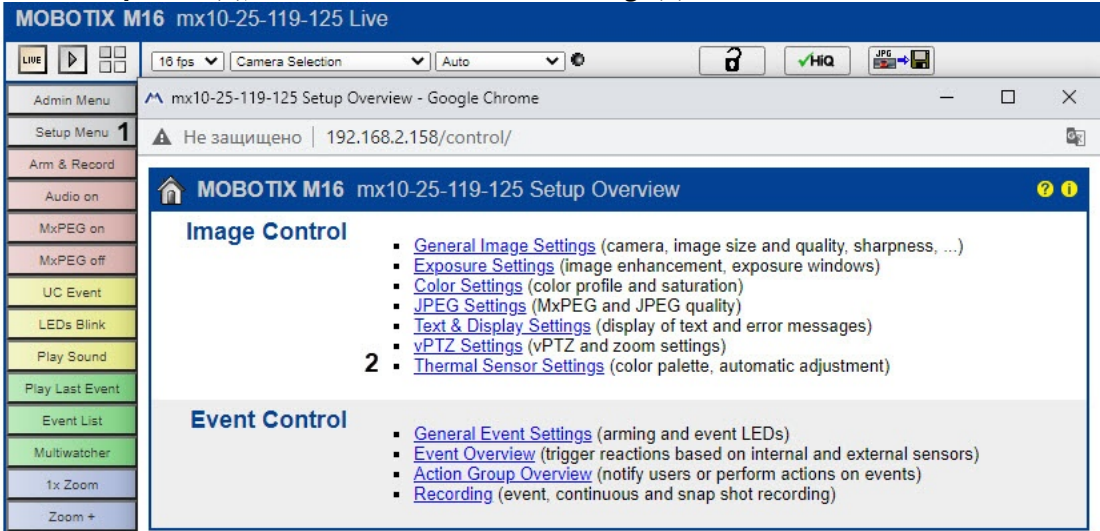

4. Select the **Temperature Compensation** checkbox (1).

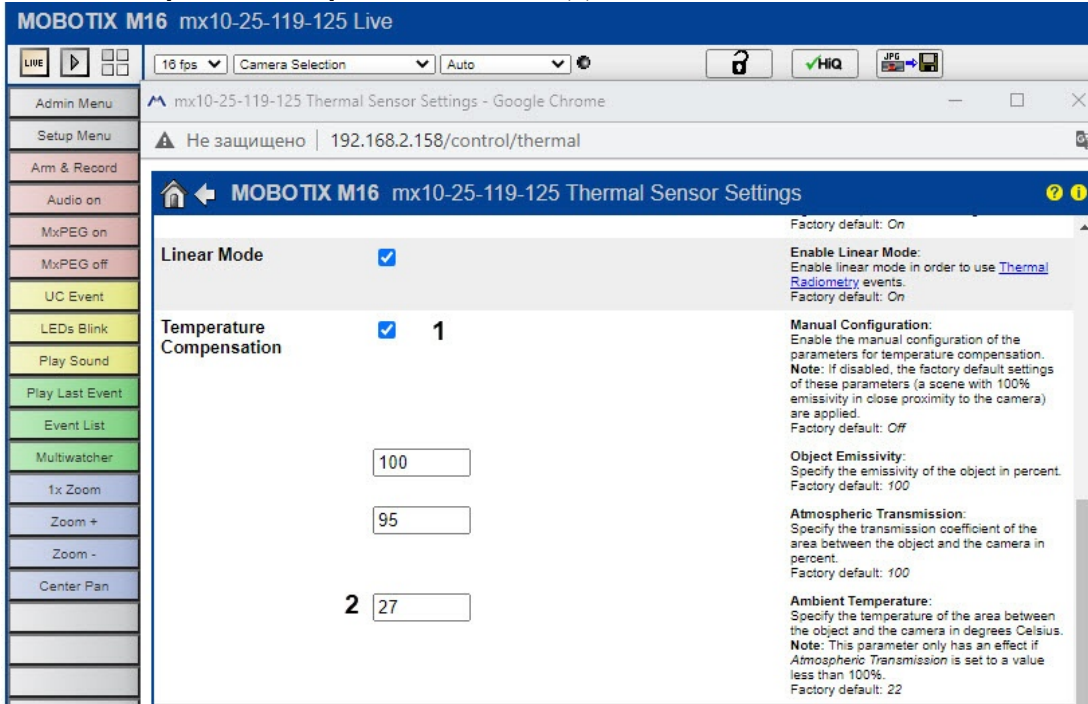

5. Enter the environmental temperature value (2, see point 2).
6. Specify the **Value Range** и **Thermal Range** parameters as shown on the screenshot.

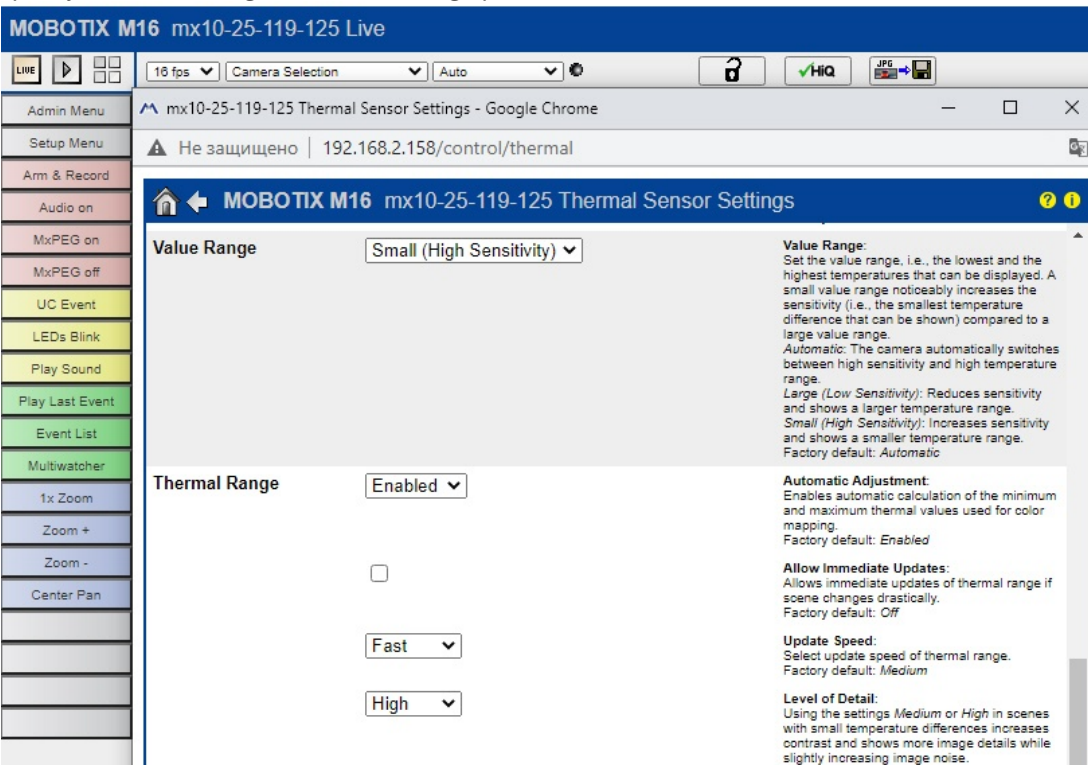

- To caption video with temperature readings, select **Display Mode (Right) (1)**, and then **Picture in Picture (2)** checkboxes.

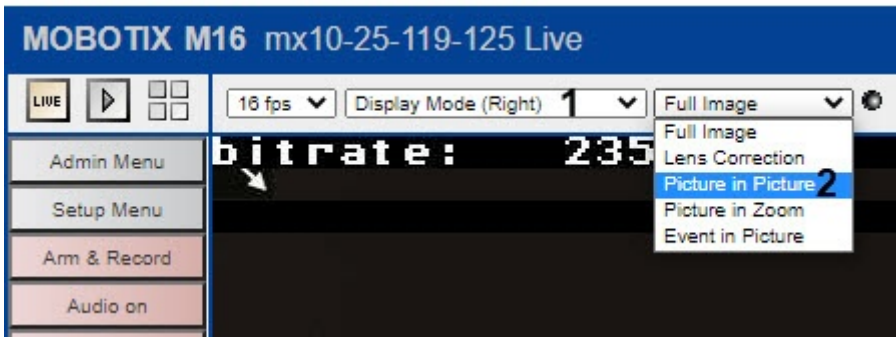

- Save the settings.

7.4.11.5 Configuring Face Detection and Temperature Control

To configure face detection and temperature control, do the following:

- Add a **Temperature Matrix Data** object in the **Embedded Detection** group.
- Under the newly added object, create a **Face Detection and Temperature Control**.
- Select temperature unit (1).

Face detection and temperature control	
Frame size change	1920
Maximum face height	100
Maximum face width	100
Minimum face height	2
Minimum face width	2
Minimum threshold of face authenticity	90
Mode	CPU
Period of face search	250
Send face images	No
2 Show thermal overlay	No
1 Temperature unit	Degree Celsius (°C)
Track loss time	500

- To caption video with thermal data, do the following:
 - Select **Yes** for the **Show Thermal Overlay** parameter (2).

- b. In the Preview window, drag anchor points  to draw an area where thermal data should be displayed.

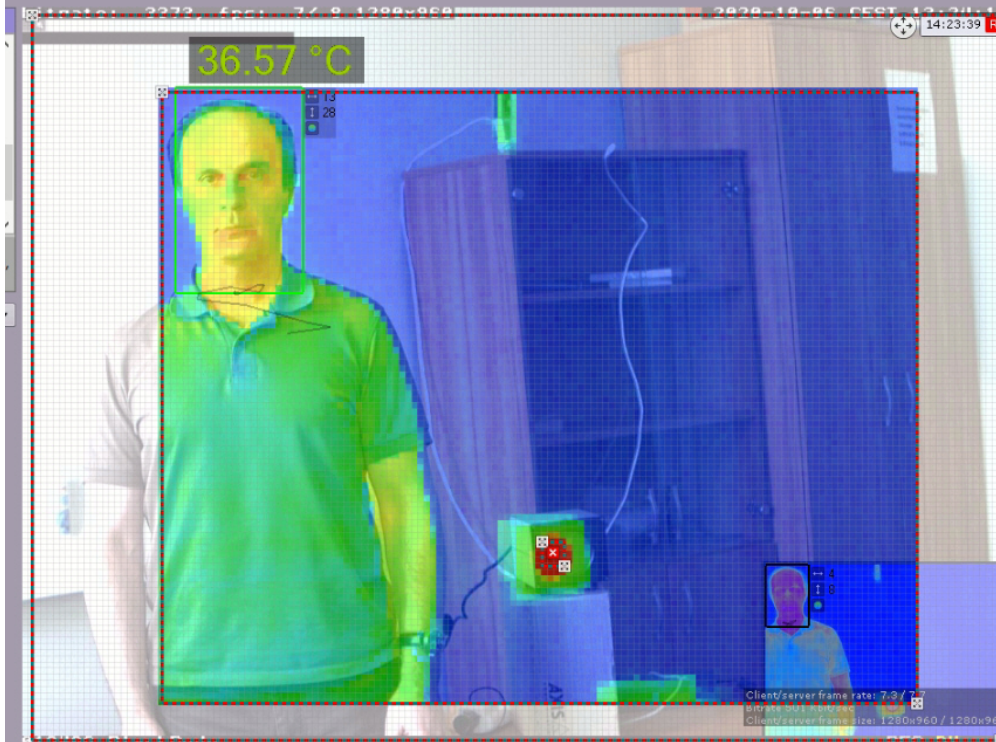

- 5. If you use an Electromagnetic Radiation Absorber (BB), do the following:
 - a. Specify its temperature (3). If temperature readings in this point are different, the bias will be used to re-calculate readings across all measurement points.

Advanced detection settings	
3 Electromagnetic radiation absorber (BB) temperature	37.5
Face detection algorithm	ALG1
Maximum face deflection rate	15
Minimum face recognition quality	50
Minimum filtering threshold	50
4 Temperature value offset	0

- b. In the Preview window, double click to add anchor points  at the position of the electromagnetic radiation absorber (BB).

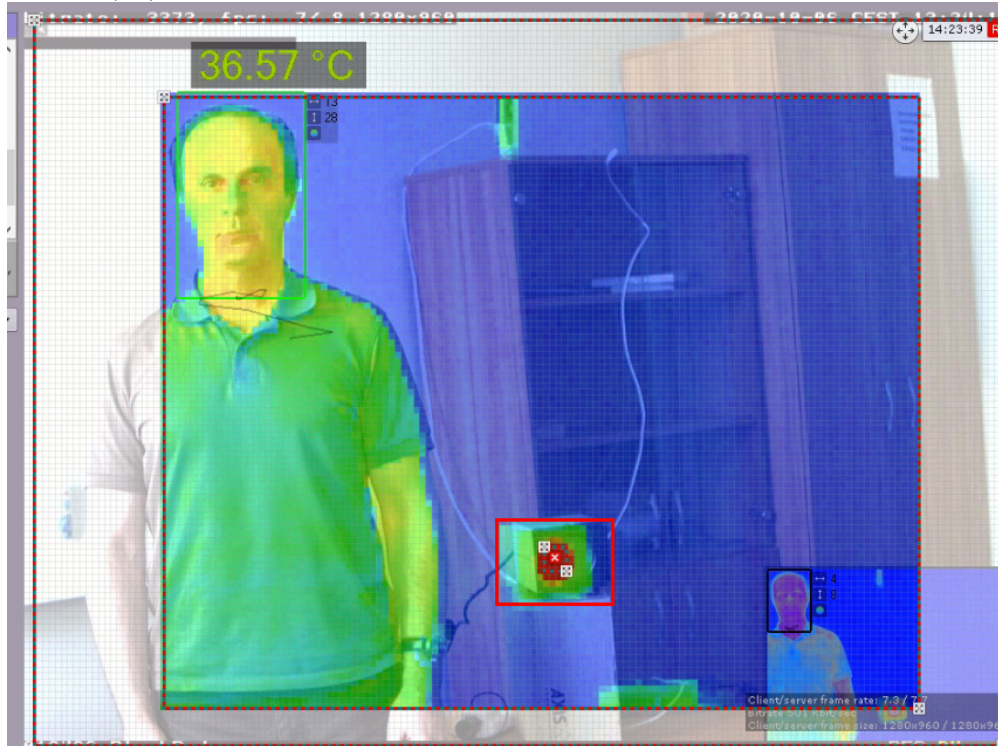

6. If you have discovered that your readings differ from actual temperature values, add the offset value into the **Temperature Value Offset** field (4). Bias values may be positive or negative.

Note

The rest of this detection tool parameters are identical to those of the basic face detection tool (see [Configure Facial Recognition](#)).

7. Click the **Apply** button.

You have configured detection tool now.

7.4.12 Automatic Number Plate Recognition (LPR/ANPR) tools

7.4.12.1 License plate recognition (VT)

7.4.12.1.1 License plate recognition (VT) features and specifications

License plate recognition (VT) (Automatic Number Plate Recognition Tool) is designed to implement the following functions:

1. Vehicle license plate recognition (the full list of supported countries is available on [vendor's website](#));
2. Write a recognized number to a database;
3. Check the recognized license plates of vehicles on the lists of license plates.

License plate recognition (VT) works in one of the following modes

1. Fast - It processes video feeds up to 25 fps with a maximum vehicle speed of 150 km/h.
2. Slow - It processes video feeds up to 6 fps with a maximum vehicle speed of 20 km/h.

Note

Install the additional Addon VT LPR to work with License plate recognition (VT).

7.4.12.1.2 Camera requirements for License plate recognition (VT)

ANPR works properly if the following camera installation requirements are met (for a list of supported countries, visit [the website](#) of the recognition module's manufacturer):

- a camera should be installed in a horizontal position (refer to [manufacturer's documentation](#)).
- character height is at least 15px, stroke width is at least 2px;
- minimum allowable contrast for uniformly contaminated license plates should be at least 10% (contrasting visibility of characters relative to the background is 25 on a 256-point scale);
- maximum allowable non-uniform contamination is no more than 12% (the ratio of the contaminated area to the total area of the license plate);
- the geometric proportions of the image shall not deviate by more than 10% from the real geometric proportions of the license plate.

Note

If you transmit MPEG-4 or H.264 streams over a stable connection, please set GOP length (Group of Pictures), i.e. the number of P- and B-frames between I-frames, to no more than 4–8 frames.

Attention!

the maximum speed of the vehicle shall not exceed 120 km/h.

For stable ANPR operation, make sure that the image of the license plate is not:

- unequally lit;



- overexposed;

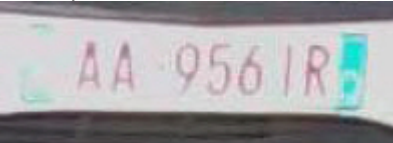

- blurred;

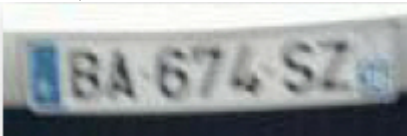

- distorted;



- interlaced;



- dirty.

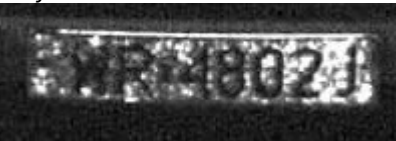

Attention!

Otherwise, recognition accuracy might be compromised.

Some example number plate images that should be recognized fully and properly:



The camera setup is described in detail in the recognition module [manufacturer's documentation](#).

7.4.12.1.3 Configuring License plate recognition (VT)

ANPR is a detection tool that reads license / number plates of vehicles in FoV.

Attention!

The license plate recognition requires a CPU that supports the SSE4.1 / SSE4.2 instructions.

Attention!

Axxon Next ANPR / LPR is not compatible with *Auto Intellect*.

Uninstall the *Axxon Next* VMS and *Auto Intellect*, then reinstall *Axxon Next*.

To configure ANPR, do as follows:

1. Select the **License plate recognition (VT)** object (1).

License plate recognition (VT)	
Object identification	
Enable	Yes
Name	License plate recognition (VT)
Object features	
2 Real-time recognition	No
3 Record objects tracking	<input checked="" type="checkbox"/> Yes
4 Video stream from camera	Low-quality video stream
Visual Elements	
> Visual Element	Detection area (rectangle)

2. If you require using this detection tool for real-time number plate recognition (see [Configuring real-time vehicle license plate recognition](#)), set the corresponding parameter to **Yes** (2).
3. If you need to enable recording of metadata, select **Yes** from the **Record Objects tracking** list (3).
4. If a camera supports multistreaming, select the stream for which detection is needed. Selecting a low-quality video stream allows reducing the load on the Server (4).
5. Select detection tool working mode: standard or neural (1).

License plate recognition (VT)		
<ul style="list-style-type: none"> ▼ Other 		
1	Analysis mode	Standard (Morph)
	Country 1 name	Albania
	Country 2 name	Not used
2	Country 3 name	Not used
	Country 4 name	Not used
	Country 5 name	Not used
3	Decoder mode	CPU
4	Frame size change	1920
5	License type	Search in archive
6	Maximum LP width	20
7	Minimum LP width	5
8	Mode	CPU
9	Number of frames	6

6. In the appropriate fields, select one or more countries for ANPR (2).

Important

The more countries you select, the slower the recognition and the greater the likelihood of the recognition error.

- 7. Select a processing resource for decoding video streams (3). When you select a GPU, a stand-alone graphics card takes priority (when decoding with NVidia NVDEC chips). If there's no appropriate GPU, the decoding will use the Intel Quick Sync Video technology. Otherwise, CPU resources will be used for decoding.
- 8. Analyzed framed are scaled down to a specified resolution (4, 1920 pixels on the longer side). This is how it works:
 - a. If the longer side of the source image exceeds the value specified in the **Frame size change** field, it is divided by two.
 - b. If the resulting resolution falls below the specified value, it is used further.
 - c. If the resulting resolution still exceeds the specified limit, it is divided by two, etc.

Note

For example, the source image resolution is 2048 * 1536, and the limit is set to **1000**.

In this case, the source resolution will be divided two times (down to 512 * 384): after the first division, the number of pixels on the longer side exceeds the limit (1024 > 1000).

9. Select the current license type (5).

License	Description
Search in archive	Basic ANPR Search License. Attention! This type of license provides a 30-sec delay between the number recognition and the corresponding event. (see Vehicle number plate recognition and search).
25 FPS or 6 FPS	The 25 FPS license has a priority. The 6 FPS license is used only if you have no 25 FPS license. You cannot use the number plate recognition function if you have no FPS licenses purchased.
25 FPS	The "Fast" license allows you to process video feeds up to 25 fps with a maximum vehicle speed of 150 km/h. You have to obtain an appropriate license to make ANPR work.
6 FPS	The "Slow" license allows you to process video feeds up to 6 fps with a maximum vehicle speed of 20 km/h. You have to obtain an appropriate license to make ANPR work.

Important

All license types except the standard one (Search in archive) require the hardware key or the software key activation (see [Activating a software license key for the ANPR](#)).

You can use a 60-day trial key (see [Activating the trial version of the ANPR via a software key](#)).

Important

On a virtual machine, you may use only a hardware key. To use a hardware key, select the 25 FPS or 6 FPS license type.

- Set the maximum and minimum width of the vehicle number plate as a percentage of the FoV width (**6, 7**).

Important

The **Minimum LP width** parameter affects the CPU load as follows: the higher the parameter is, the higher the load.

- Choose a processor to run detection on (**8**). In standard mode, detection runs on the CPU only.
- Set the number of frames required for LPR / ANPR (**9**). This is though a necessary condition, but not sufficient for the first output. This condition delays LPR output. This parameter allows to increase the reliability of the results, as well as to hide false positives.
- If necessary, configure advanced detection settings (see [Fine-tuning the VT number plate detection tool](#)).
- You can configure an ANPR zone in FoV. The zone is resized by moving the anchor points.

**Note**

For your convenience, you can click the  button and configure the mask on a still frame / snapshot. To undo, click this button again.

Note

Detection zone is displayed by default. You can click the  button to hide the zone. To undo, click this button again.

15. Click the **Apply** button.

Configuration of ANPR is now complete.

7.4.12.1.4 Fine-tuning the VT number plate detection tool

Attention!

To fine tune this detection tool, you will require assistance from AxxonSoft tech support.

To fine-tune the detection tool, do as follows:

1. If necessary, enable advanced image analysis (1).

Yes – improves the quality of recognition under adverse conditions (for example, if the characteristics / settings of the camera do not fully meet the requirements, or in bad weather). The processing time of the frame increases by 20-30%, depending on its size. Under normal conditions, this setting does not affect the quality of recognition

License plate recognition (VT)		
Number of frames	6	
▼ Advanced detection settings		
Advanced image analysis	No	1
Algorithm of recognition of distorted LP image	No	2
Contrast threshold	40	3
LP advanced search algorithm	No	4
LP display quality	0	5
Maximum number of threads	1	6
Minimum similarity	40	7
Timeout	0	8
Tracker timeout, sec	3	9

2. To recognize the numbers at sharp angles with respect to the camera, select **Yes** in the **Algorithm of recognition of distorted LP image** field (2).
3. Set the image contrast threshold (3). The default value is **40**. On a high-quality image, increase this value to 50-60. If the image has poor contrast, lower this value.
4. If you expect different sizes of number plates within FOV, activate the **LP advanced search algorithm** (4). This parameter accounts for max and min width of number plates, and, in some cases, may help increasing recognition quality and optimizing CPU load.
5. To set up a number plate recognition event:
 - a. Specify the minimum percentage of similarity between the recognition result and the corresponding number plate template, for positive LPR result (7). Use this parameter to filter the results by reliability.
 - b. By default, a number plate recognition event is registered after a track containing a number plate disappears from FOV. You can set the moment of registration to a **Timeout** in seconds (8), or to reaching a similarity percentage specified in the **LP display quality** field (5). If both parameters are set to non-zero, the recognition event will be registered upon matching the first condition.

Note

The **LP display quality** parameter value must be no lower than the **Minimum similarity** value.

6. Specify the maximum number of recognition threads (6). If the value is **0**, the recognition process will occur in the same thread that starts it.

Important

The cumulative value of this parameter across all NPR detection tools must not exceed:

- the licensed number of recognition threads (check your license with the lsvpwcutility – [please refer to manufacturer's documentation](#));
- the number of CPU cores;
- 100.

7. In the **Tracker Timeout** field, set a time interval in seconds after which the tracking of a vehicle is reset (**10**).

Note

Use this setting to eliminate double-triggering in such cases as, for example, another recognition of the same number after it has been obstructed for some time, and then reappears in scene.

If you set Tracker Timeout to a value greater than a probable time of obstruction, the detection tool will not double-trigger.

8. If necessary, set additional parameters. For more details, refer to the table.

License plate recognition (VT)	
Tracker timeout, sec	3
VodiCTL_VPW_DYNAMIC_ENABLE	Yes
VodiCTL_VPW_DYNAMIC_OUTPUT_PERIOD	0.5
VodiCTL_VPW_DYNAMIC_OUTPUT_TIMEOUT	1
VodiCTL_VPW_DYNAMIC_WITH_DUPLICATE	Yes
VodiCTL_VPW_IMAGE_BLUR	13
VodiCTL_VPW_LOG_SETTINGS	No
VodiCTL_VPW_PLATE_FILTER_RODROFFACTOR	0
VodiCTL_VPW_PLATE_FILTER_ROFACTOR	95
VodiCTL_VPW_PLATE_FILTER_SYMCOUNT	0
VodiCTL_VPW_PLATE_STAR_MAX	0

Parameter	Description
VodiCTL_VPW_DYNAMIC_ENABLE	Enable/disable the number recognition dynamics (by default, the dynamics is enabled). If the value is Yes , then tracking is enabled, and the number is recognized by the set of frames. If the value is No , then tracking is disabled, and the number is recognized by each frame separately without taking into account the previous ones, and the quality can vary from 0 to 100%.
VodiCTL_VPW_DYNAMIC_OUTPUT_PERIOD	Time period (in microseconds) over which the recognition result is to be displayed to the user. This parameter can be used only if the VodiCTL_VPW_DYNAMIC_WITH_DUPLICATE parameter is set.
VodiCTL_VPW_DYNAMIC_OUTPUT_TIMEOUT	The minimum time required to monitor the license plate (in microseconds) before displaying the recognition result to the user. This parameter can only be used when the “Dynamic” mode is on. In this mode, the trajectory of the vehicle is monitored, and the user does not immediately receive the recognition result of the license plate, but after the time specified for this setting. In this case, the first recognition result will be replaced by the result of higher quality and subsequently displayed to the user. If parameter 0 is set for this value, the user gets the first result of recognizing the detected license plate. After the time specified in this parameter expires, the monitoring of the trajectory of the license plate continues until it disappears from the frame.
VodiCTL_VPW_DYNAMIC_WITH_DUPLICATE	Enable/disable the periodic output of license plate recognition results.
VodiCTL_VPW_IMAGE_BLUR	The parameter for internal use. The recommended value to set is 13.

VodiCTL_VPW_LOG_SETTINGS	Enable/disable logging of all recognition parameters.
VodiCTL_VPW_PLATE_FILTER_RODROPFACOR	The license plate filter coefficient by the so-called image density - ratio of white pixels to total pixels (second strategy). The type is unsigned. This coefficient is used for image thresholding and has the optimal values, which are determined by AutoSDK developers using their own test samples. The parameter is considered as a service one, and its value should be set according to the recommendations of technical support specialists.
VodiCTL_VPW_PLATE_FILTER_ROFACTOR	The license plate filter coefficient by the so-called image density - ratio of white pixels to total pixels (first strategy). The type is unsigned. This coefficient is used for image thresholding and has the optimal values, which are determined by AutoSDK developers using their own test samples. The parameter is considered as a service one, and its value should be set according to the recommendations of technical support specialists.
VodiCTL_VPW_PLATE_FILTER_SYMCOUNT	Enable/disable the simple license plates filter algorithm by the minimum number of recognized symbols on them. If the algorithm is enabled (the value of the parameter is greater than 0), the base search for symbols on the prospective license plate (geometry, proportions) is performed. If less symbols are recognized on the prospective license plate than specified in this parameter, this prospective license plate is not considered a license plate. That is, the value of this parameter is the minimum characters that must be present on the prospective license plate when the basic algorithm is in use.
VodiCTL_VPW_PLATE_STAR_MAX	Maximum unrecognized symbols on the license plate, at which the result will still be considered the result of the recognition of the license plate.

9. Click the **Apply** button.

7.4.12.1.5 Activating a software license key for the ANPR

Attention!

In a Failover system, the ANRP license is not automatically transferred to a new node (see [Configuring Failover VMS](#)). To enable the detection tool, you need to manually activate the license on the PC where the new node is launched.

On order to receive the software license key for the ANPR, proceed as follows:

1. Download the utilities by the links below:
 1. [haspdinst_EOAWT.exe](#)
 2. [RUS_EOAWT.exe](#)
- In the Windows command line, execute the following two commands one after another to install the protection key driver:

```
haspdinst_EOAWT.exe -fr -purge
haspdinst_EOAWT.exe -i -fi -fss
```

Note

Make sure that the current directory in the command line is similar to the one where the haspdinst_EOAWT.exe file is located.

- Wait for the installation completion.

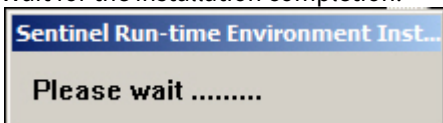

- Click **OK** in the dialog box to confirm installation is completed.

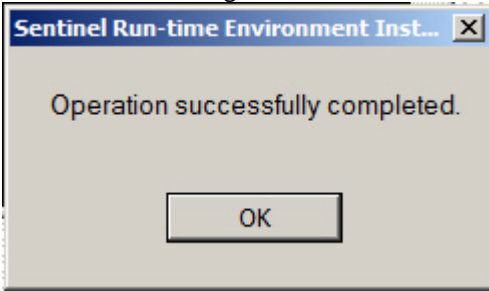

- Check installation correctness by opening the http://127.0.0.1:1947/_int_/ACC_help_index.html page in the web browser.

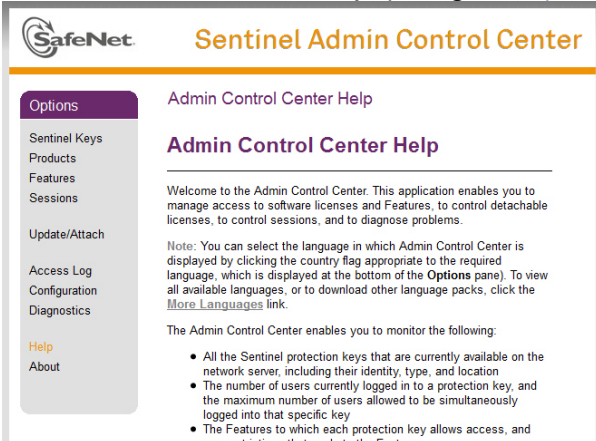

- Run the hasp_RUS.exe file to start the Remote Update System. The **RUS** dialog box opens.

Note.
The RUS abbreviation stands for Remote Update System.

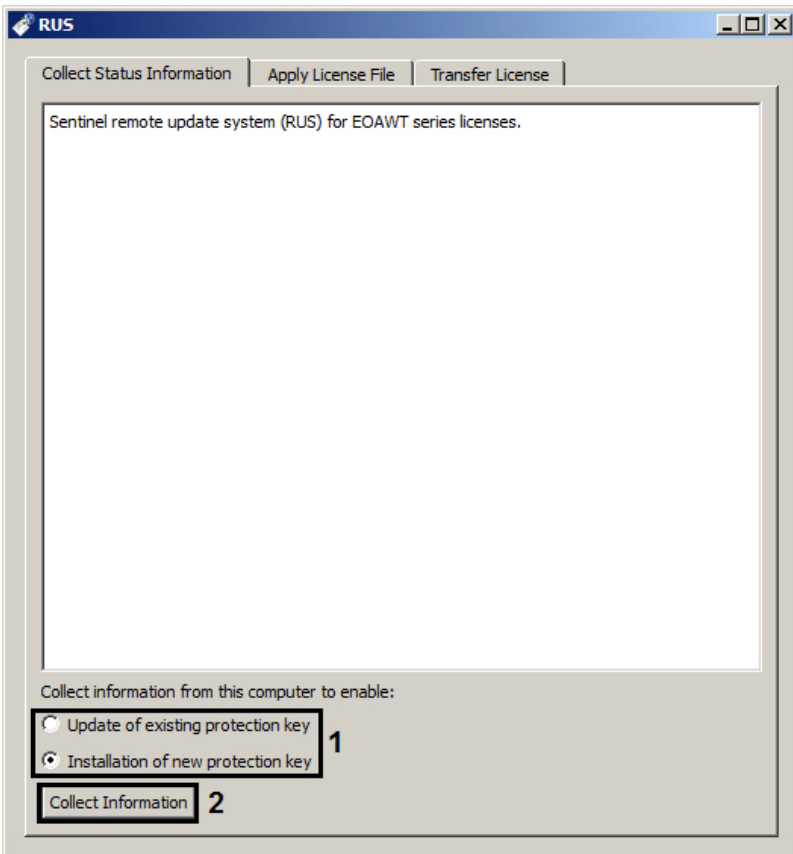

- Set the **Collect information from this computer to enable:** switch into the **Installation of new protection key** position in case if license for a "clean computer" is needed, i.e. if there is no demo license on it, or to the **Update of existing protection key** position, if demo license is already in use (1).
- Click **Collect information**.
- Save the file with .c2v extension to any folder.
- Close the hasp_RUS.exe tool.
- Hand the .c2v file to your AxxonSoft manager.
- Receive the license file with .v2c extension from your AxxonSoft manager.
- Run the hasp_RUS.exe tool and go to the **Apply License File** tab (1).

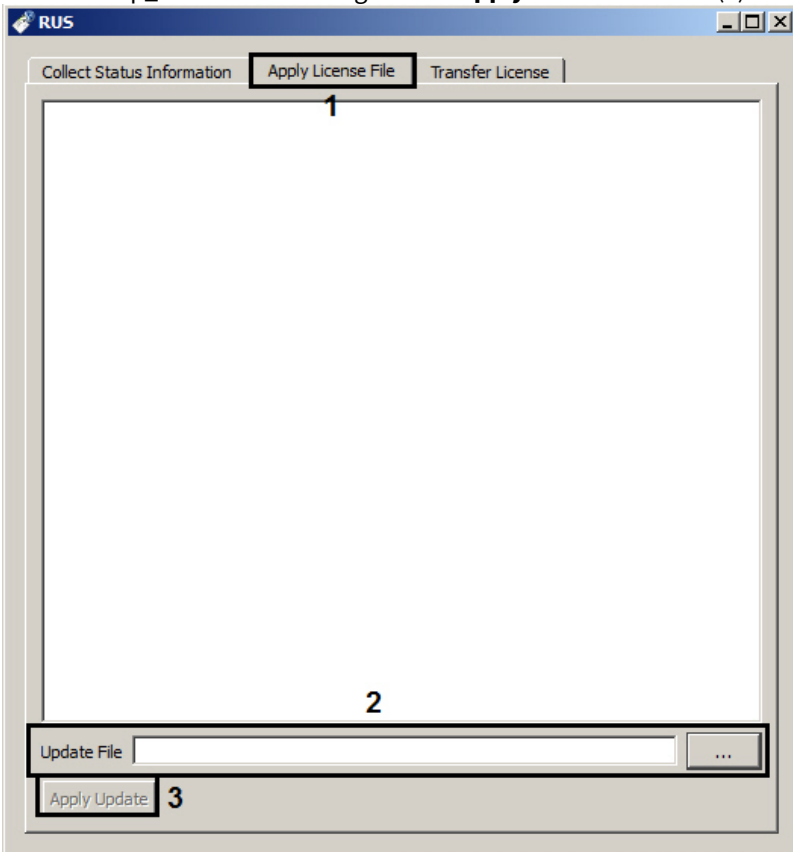

- Specify location of the license file in the **Update File** field using the ... button (2).
- Click **Apply Update** (3).

Receiving the software license key for the ANPR is now completed.

7.4.12.1.6 Activating the trial version of the ANPR via a software key

You can use the ANPR in trial mode.

In this mode, the number of channels is limited to 4 in both 25 FPS and 6 FPS versions for all available countries. Activate the software key to start the 60-day trial.

Attention!

You cannot operate the ANPR tool in trial mode on a virtual machine.

To activate the ANPR in trial mode, do the following:

1. Download the distribution package: [25 FPS](#) or [6 FPS](#).
2. Start the command line (Run as administrator).
3. Execute the following command **SDK_4hi_60d_WORLD.exe -i -fi -fss** for a 25 FPS trial license, or **SDK_4lo_60d_WORLD.exe -i -fi -fss** for a 6 FPS trial license.

The demo license is now activated.

7.4.12.2 License plate recognition (IV)

7.4.12.2.1 License plate recognition (IV) features and specifications

License plate recognition (IV) is designed to implement the following functions:

1. Vehicle license plate recognition (the full list of supported countries is available in [vendor's specifications](#), motorcycle license plate recognition only for Brazil);
2. Write a recognized number to a database;
3. Check the recognized license plates of vehicles on the lists of license plates.

Note

Install the additional Addon IV LPR to work with License plate recognition (IV).

Attention!

Only a 64-bit version is available.

7.4.12.2.2 Camera requirements for License plate recognition (IV)

• Camera specifications

- The minimum video resolution is 640*480, the recommended resolution is 720p or 1080p.
- The minimum frame rate is 15 fps, the recommended frame rate is 25-30 fps.
- Auto Focus and Zoom would be useful for making small adjustments after setting up ANPR.
- Automatic white balance / automatic gain.
- IR for night mode with good contrast of license plate images.
- HDR / WDR

• Video requirements

- The video image should be clear, contrasting, without distortion, not blurred.
- The size of the license plate should be 15 - 70% of the total size of the image.
- The license plate must contain no more than two rows of characters.

• Camera installation requirements

- The video camera should be mounted at 0.6 - 2.4 meters above the ground.
- The angle formed by the lower line of the license plate and the horizon line should be from 0 to 20 degrees.

Important!

It is also recommended to study the [manufacturer's specification](#).

7.4.12.2.2.1 Examples of correct and incorrect video images

Video images that meet the video camera mounting and setup requirements for the Licence plate recognition (IV).





Video images that do not meet the video camera mounting and setup requirements for the Licence plate recognition (IV).

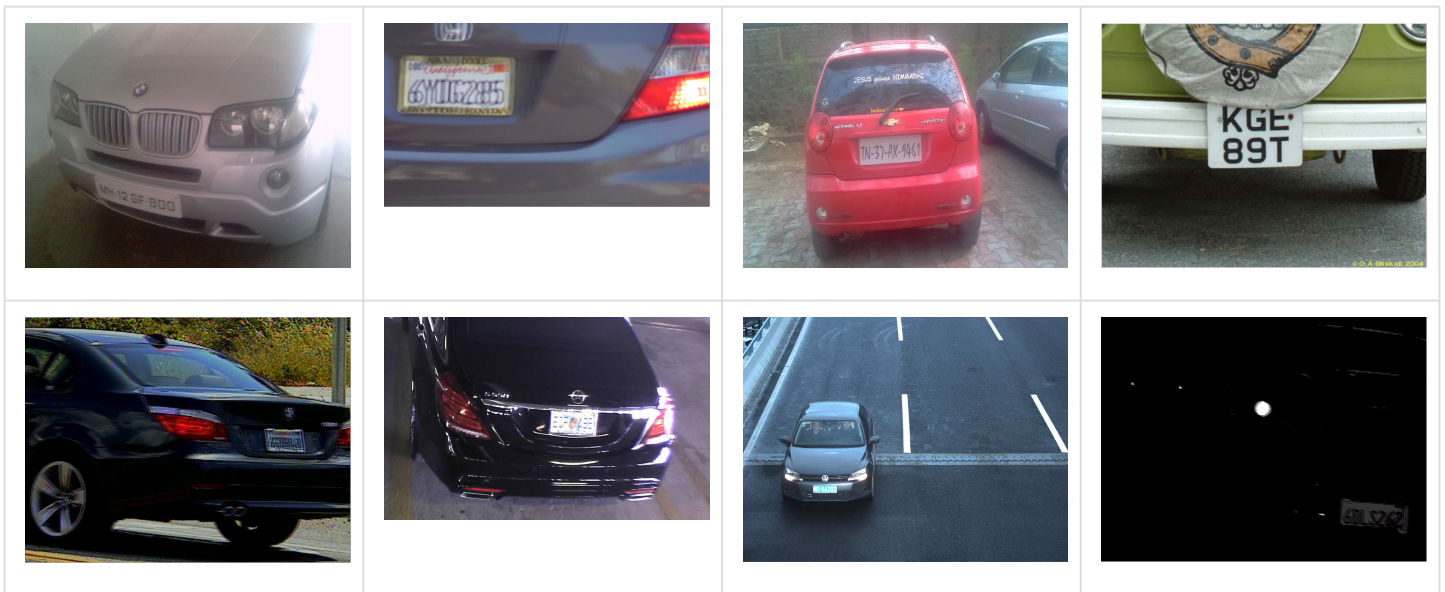

7.4.12.2.3 Configuring License plate recognition (IV)

To configure License plate recognition (IV), do as follows:

1. Download Addon IV LPR from the [website](#) and install it.
2. Submit the MAC address of the Server intended for detection tool operation to Axxon's tech support.

Attention!

The detection tool will not operate on a Server having a different MAC address.

3. Copy an IntelliVision license into C:\Program Files\Common Files\AxxonSoft\DetectorPack\IntelliVisionLPRlicense.txt.
4. Restart the Server (see [Shutting down a Server, Starting a Server](#)).

5. Select the **License plate recognition (IV)** object (1).

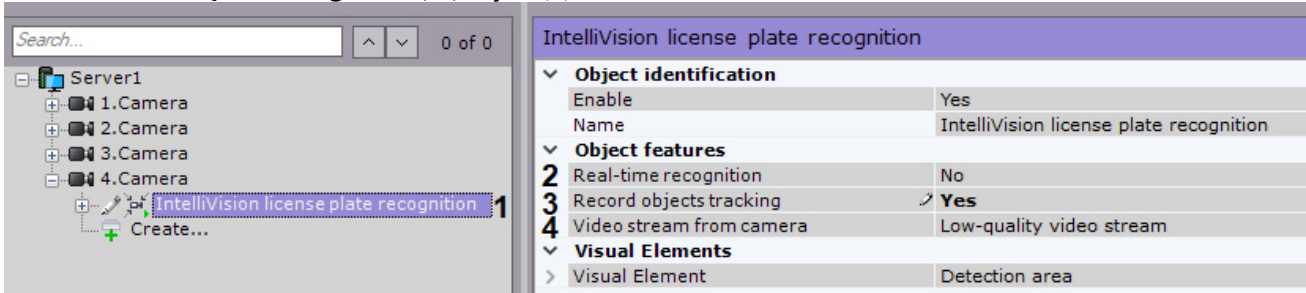

- 6. If you require using this detection tool for real-time number plate recognition (see [Configuring online Vehicle License Plate recognition](#)), set the corresponding parameter to **Yes** (2).
- 7. If you need to enable recording of metadata, select **Yes** from the **Record Objects tracking** list (3).
- 8. If a camera supports multistreaming, select the stream for which detection is needed. Selecting a low-quality video stream allows reducing the load on the Server (4).
- 9. Select the country from the list (1).

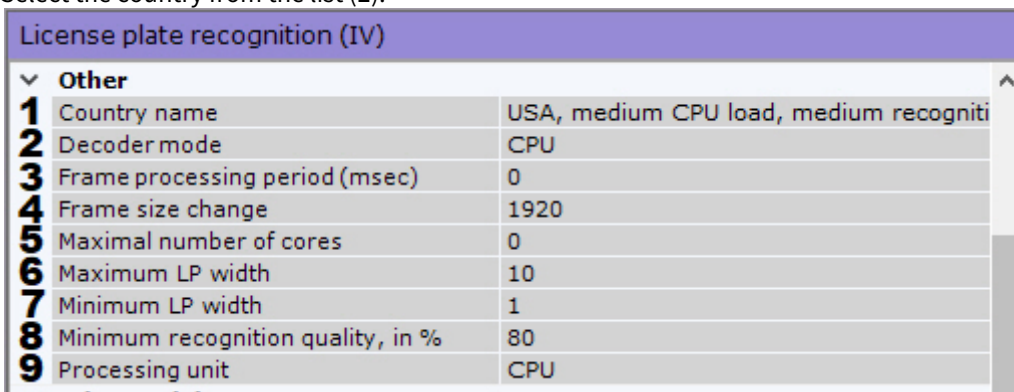

Attention!

Several profiles are provided for India, USA, Russia, Taiwan, Australia and African countries, differing by recognition parameters and hardware requirements.

To recognize US license plates with vertical orientation of characters, a profile with higher accuracy of recognition is recommended.

Note

The list of supported countries is given in the [manufacturer's specifications](#).

- 10. Select a processing resource for decoding video streams (2). When you select a GPU, a stand-alone graphics card takes priority (when decoding with NVidia NVDEC chips). If there's no appropriate GPU, the decoding will use the Intel Quick Sync Video technology. Otherwise, CPU resources will be used for decoding.
- 11. Specify the minimum number of milliseconds between frames during recognition (3).
- 12. Analyzed framed are scaled down to a specified resolution (4, 1920 pixels on the longer side). This is how it works:
 - a. If the longer side of the source image exceeds the value specified in the **Frame size change** field, it is divided by two.
 - b. If the resulting resolution falls below the specified value, it is used further.
 - c. If the resulting resolution still exceeds the specified limit, it is divided by two, etc.

Note

For example, the source image resolution is 2048 * 1536, and the limit is set to **1000**.

In this case, the source resolution will be divided two times (down to 512 * 384): after the first division, the number of pixels on the longer side exceeds the limit (1024 > 1000).

- 13. Specify the maximum number of processor cores available for the detector. '0' means all cores (5).
- 14. Set the maximum and minimum width of the vehicle number plate as a percentage of the FoV width (6, 7).
- 15. Set minimum quality of ANPR (8). The higher the minimum recognition quality, the less false detections will occur.
- 16. By default, CPU resources are solely used for recognition. If you want to apply GPU computing resources to increase the recognition performance, select GPU in the Processor Type field (9).
- 17. Specify the maximum and minimum number of digits in the number (1, 2).

Advanced detection settings		
1	Maximal number of characters in LP	10
2	Minimal number of characters in LP	5
3	Recognition accuracy level	Maximal accuracy
4	Timeout	0
5	Tracker timeout, sec	3

- 18. Select recognition accuracy (3):
 - a. Maximum: offers maximum recognition accuracy at the expense of higher CPU / GPU load.
 - b. High: offers acceptable recognition accuracy for less CPU / GPU effort.
 - c. Fast: offers fastest recognition speed at the expense of accuracy.
- 19. Specify the time interval between the initial recognition and event registration in the **Timeout** field (4). **Zero** value sets the event registration to the moment when the track disappears from FOV.
- 20. In the **Tracker timeout** field, enter a time period in seconds. This is the time before detection starts again after a number plate is recognized (5).
- 21. You can configure an ANPR zone in FoV. The zone is resized by moving the anchor points .

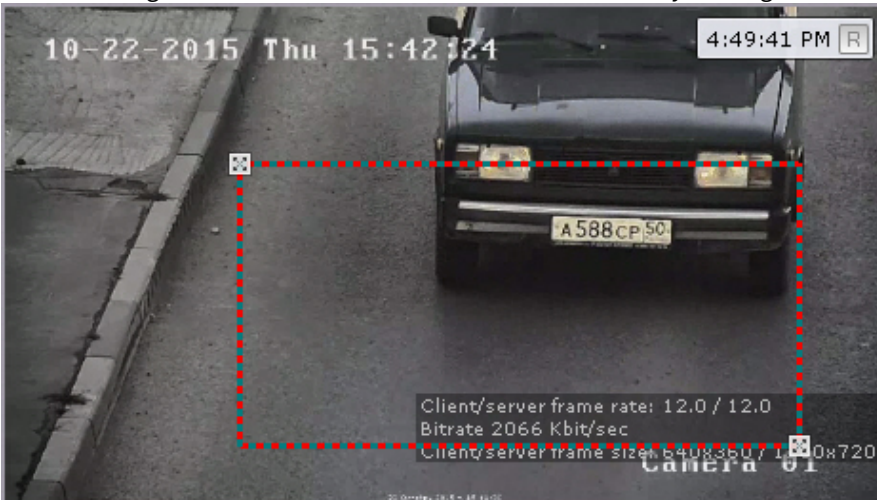

Note

For your convenience, you can click the  button and configure the mask on a still frame / snapshot. To undo, click this button again.

Note

Detection zone is displayed by default. You can click the  button to hide the zone. To undo, click this button again.

22. Click the **Apply** button.

Configuration of License plate recognition (IV) is now complete.

7.4.12.3 Licence plate recognition (RR)

7.4.12.3.1 License plate recognition (RR) features and specifications

The License plate recognition (RR) is designed to implement the following features:

1. license/number plate recognition;

Note

List of supported countries: Armenia, Azerbaijan, Belarus, Estonia, Georgia, Kyrgyzstan, Kazakhstan, Lithuania, Latvia, Moldova, Russia, Ukraine, Uzbekistan, Vietnam, Peru, Spain, Mexico, Poland, Myanmar.

2. write a recognized number to a database;
3. check the recognized license plates of vehicles on the lists of license plates.

Depending on the features required, the Axxon Next VMS offers three types of License plate recognition (RR) tools:

License plate recognition (RR)

License plate recognition - Parking (RR)

License plate recognition - Search in archive (RR)

1. **License plate recognition (RR)** - recognizes number plates in real time. Recognition is performed in Fast mode (video stream processing at a speed of up to 30 fps).
2. **License plate recognition - Parking (RR)** - recognizes number plates in real time. Recognition is performed in Slow mode (video stream processing at a speed of up to 8 fps).

Note

The sampling rate for detection tool is 150 milliseconds, all other frames are skipped.

3. **License plate recognition - Search in archive (RR)** - recognizes number plates in recorded video. Recognition is performed in Fast mode (video stream processing at a speed of up to 30 fps).

Note

This detection tool generates events with a 30 sec delay after number recognition.

Note

License plate recognition (RR) requires Addon RR LPR to be installed (see [Installing DetectorPack add-ons](#)).

7.4.12.3.2 Camera requirements for License plate recognition (RR)

ANPR works properly if the following camera specs, installation, and configuration requirements are met:

- Character height at least 10p, preferably 20p or more;
- Minimum resolution 1280*720, recommended 1920*1080;
- Minimum frame rate for Slow mode 5 fps mode, for Fast mode 20 fps;
- Maximum horizontal angle: 30°;
- maximum vertical angle: 45°;
- Expected image contrast: the contrast difference between characters of the number plate and the background should be at least 20 units with an image brightness scale of 0 to 255.

7.4.12.3.3 Configuring License plate recognition (RR)

To configure License plate recognition (RR), do as follows:

1. Download Addon RR LPR from the [website](#) and install it.

Note

To make the detection tool work under Windows Server 2012 R2, make sure to install the Media Foundation component.

2. Create the detection object you need and select it (1).

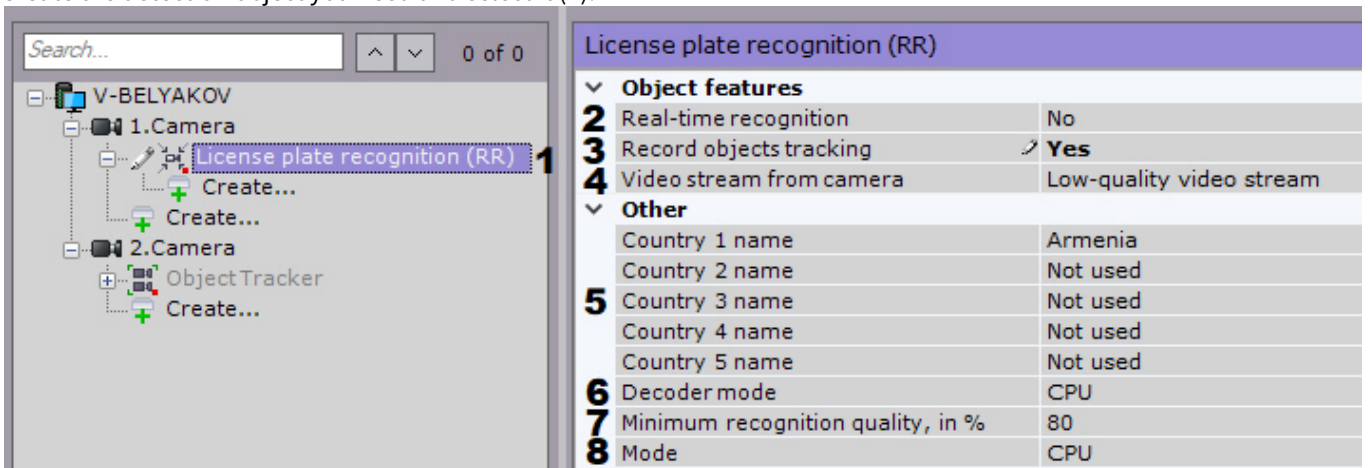

3. If you require using this detection tool for real-time number plate recognition (see [Configuring real-time vehicle license plate recognition](#)), set the corresponding parameter to **Yes** (2).
4. If you need to enable recording of metadata, select **Yes** from the **Record Objects tracking** list (3).
5. If a camera supports multistreaming, select the stream for which detection is needed. Selecting a low-quality video stream allows reducing the load on the Server (4).
6. Select your target country from the list (5).
7. Select a processing resource for decoding video streams (6). When you select a GPU, a stand-alone graphics card takes priority (when decoding with NVidia NVDEC chips). If there's no appropriate GPU, the decoding will use the Intel Quick Sync Video technology. Otherwise, CPU resources will be used for decoding.
8. Set minimum quality of ANPR (7). The higher the minimum recognition quality, the less false detections will occur.
9. Select the processor for the detection tool: the CPU or one of NVidia GPUs (8).

Attention!

It may take up to one minute to launch the algorithm on an NVIDIA GPU.

10. Specify the time interval between the initial recognition and event registration in the **Force report timeout** field (10). **Zero** value sets the event registration to the moment when the track disappears from FOV.

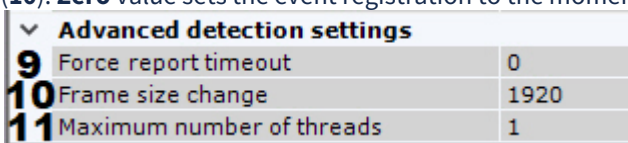

Note

Skip this step with **License plate recognition - Search in archive (RR)**.

11. Analyzed framed are scaled down to a specified resolution (**10**, 1920 pixels on the longer side). This is how it works:
 - a. If the longer side of the source image exceeds the value specified in the **Frame size change** field, it is divided by two.
 - b. If the resulting resolution falls below the specified value, it is used further.
 - c. If the resulting resolution still exceeds the specified limit, it is divided by two, etc.

Note

For example, the source image resolution is 2048 * 1536, and the limit is set to **1000**.

In this case, the source resolution will be divided two times (down to 512 * 384): after the first division, the number of pixels on the longer side exceeds the limit (1024 > 1000).

12. Specify the maximum number of recognition threads (**11**). If the value is **0**, the recognition process will occur in the same thread that starts it.

Attention!

The cumulative value of this parameters across all LPR detection tools must not exceed the number of CPU cores and is limited to **100**.

13. You can configure an ANPR zone in FoV. The zone is resized by moving the anchor points .

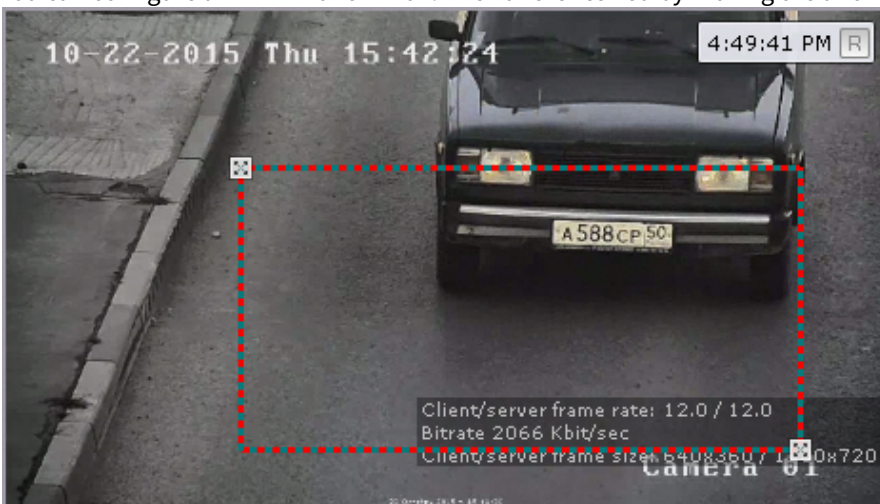

Note

For your convenience, you can click the  button and configure the mask on a still frame / snapshot. To undo, click this button again.

Note

Detection zone is displayed by default. You can click the  button to hide the zone. To undo, click this button again.

14. Click the **Apply** button.

Configuration of License plate recognition (RR) is now complete.

7.4.12.4 Configuring real-time vehicle license plate recognition

You can program automatic responses to an identification of a recognized LP against an external list (for example, of wanted vehicles).

To do it, follow the steps below:

1. Activate the **Real-time Recognition** parameter for the required detection tools (see [Configuring License plate recognition \(VT\)](#)).
2. Create one or more Lists of LPs (see [Lists of vehicle numbers](#)).
3. Add reference images of LPs of interest to the lists.
4. Configure automatic responses to positive identification against the list (see [Setting the automatic response to an identification of a recognized LP against the list](#)).

7.4.12.4.1 Setting the automatic response to an identification of a recognized LP against the list

To set an automatic response to an FR event, do as follows:

1. Create a macro (see [Create Macros](#)).
2. As a starting condition, select the **License plate recognition** event and the desired list (**1**, see [Configuring filters for event-driven macros](#)).

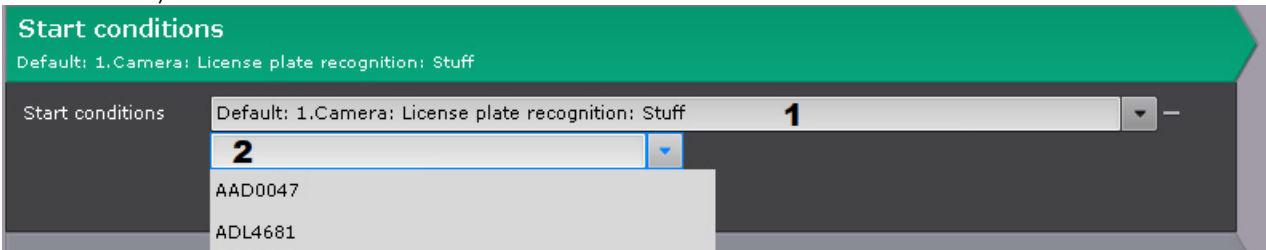

3. By default, the macro is triggered by recognition of any number from the list. If required, you can specify a particular number whose recognition will trigger the macro (**2**).

Note

To select another number, clear the **2** field and re-open the list.

4. Program an action or a sequence of actions to be performed in response to an identification of a recognized LP against the designated list (see [Settings specific to actions](#)).
5. If the response involves initiating an alarm, you can configure the Dialog Board to filter **Alarm Initiated by Macro Command** events (see [Configure the Dialog Board](#)).

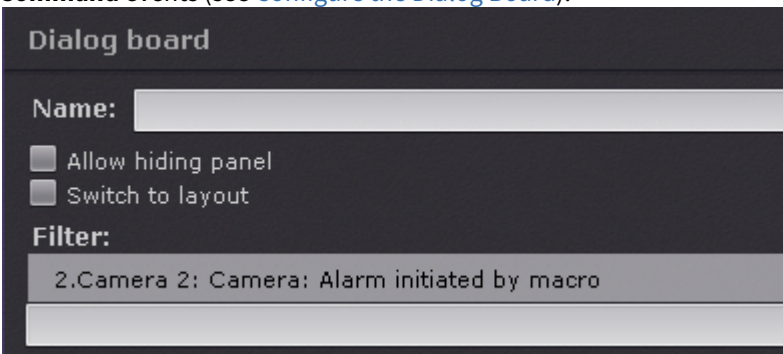

7.4.13 Neural Counter

7.4.13.1 Camera requirements for neural counter operation

To operate the neural counter, a camera must match the following requirements:

1. Minimum resolution is at least 640x360 pixels.
2. Frame rate is no less than 2 FPS (no less than 4 FPS is recommended).
3. Objects must be visually separated from the background as well as from each other.
4. Camera is mounted in no less than 3 meters above the ground, or on the ceiling.
5. An object must occupy no less than 5% of the FoV width / height.

Attention!

We cannot guarantee normal operation of the neural counter with a fisheye camera.

7.4.13.2 Functions of the neural counter

The Neuralcounter relies on a neural network to work out the number of objects in the zone.

A detection event that can be used to launch a macro is generated when the number of objects in FoV matches the pre-defined conditions (see [Configuring filters for event-driven macros](#)).

Note

Unlike the Multiple objects detection tool (see [Settings Specific to Multiple objects](#)), Neuralcounter generates events of one type, namely - triggering.

Neuralcounter is less resource-intensive than Multiple objects detection tool based on Neural Tracker.

Note

For the neural counter to work, install Addon Neuro Pack (see [Installing DetectorPack add-ons](#)).

7.4.13.3 Configuring a Neuralcounter

To configure Neuralcounter, do the following:

1. If a camera supports multistreaming, select the stream to apply the detection tool to **(1)**.

Neurocounter		
1	Video stream from camera	Low-quality video stream
	Other	
2	Decoder mode	CPU
3	Detected objects	No
4	Detection threshold	30
5	Frame processing period (sec)	1
6	Mode	CPU
7	Neural network file	
8	Number of alarm objects	5
9	Number of measurements in a row to trigger	3
10	Trigger upon count	Greater than threshold value

2. Select a processing resource for decoding video streams **(2)**. When you select a GPU, a stand-alone graphics card takes priority (when decoding with NVidia NVDEC chips). If there's no appropriate GPU, the decoding will use the Intel Quick Sync Video technology. Otherwise, CPU resources will be used for decoding.
3. If you need to outline objects in the preview window, select **Yes** in the **Detected Objects** parameter **(3)**.
4. Set the recognition threshold for objects in percent **(4)**. If the recognition probability falls below the specified value, the data will be ignored. The higher the value, the higher the accuracy — for the cost of sensitivity.
5. Set the interval between the analyzed frames in seconds **(5)**. The value should be within the range of 0,05 – 30.
6. Set the minimum number of frames with excessive numbers of objects for Neuralcounter to trigger **(9)**. The value should be within the range of 2 – 20.

Note

The default values (3 frames and 1 second) indicate that Neuralcounter will analyze one frame every second. If Neuralcounter detects more objects than the specified threshold value on 3 frames, then it triggers.

7. Select the processor for the neural network - CPU, one of GPUs, or **Intel NCS** (6, see [Hardware requirements for neural analytics operation](#)).

Attention!

It may take several minutes to launch the algorithm on an NVIDIA GPU after you apply the settings.

Attention!

If you specify other processing resource than the CPU, this device will carry the most of computing load. However, the detection tool will consume CPU as well.

8. Select the neural network file (7).

Note

For correct neural network operation under Linux, place the corresponding file in the `/opt/AxxonSoft/AxxonNext/` directory.

9. Set the triggering condition for the neural counter:
 - a. In the **Number of alarm objects** field, set the threshold value for the number of objects in FoV (8).
 - b. In the **Trigger upon count** field, select the condition polarity: whether triggering should occur on exceeding the threshold, or dropping below it (10).
10. In the preview window, you can set the detection zones with the help of anchor points much like privacy masks in Scene Analytics (see [Setting General Zones for Scene Analytics](#)). By default, the entire FoV is a detection zone.



11. Click **Apply**.

After the neural tracker is created, the layout can display the sensor icon with the number of objects within the controlled area. To configure this option, please follow the steps below:

1. Proceed to the Layout Editing mode (see [Switching to layout editing mode](#)).

- Place the sensor anywhere in FoV.

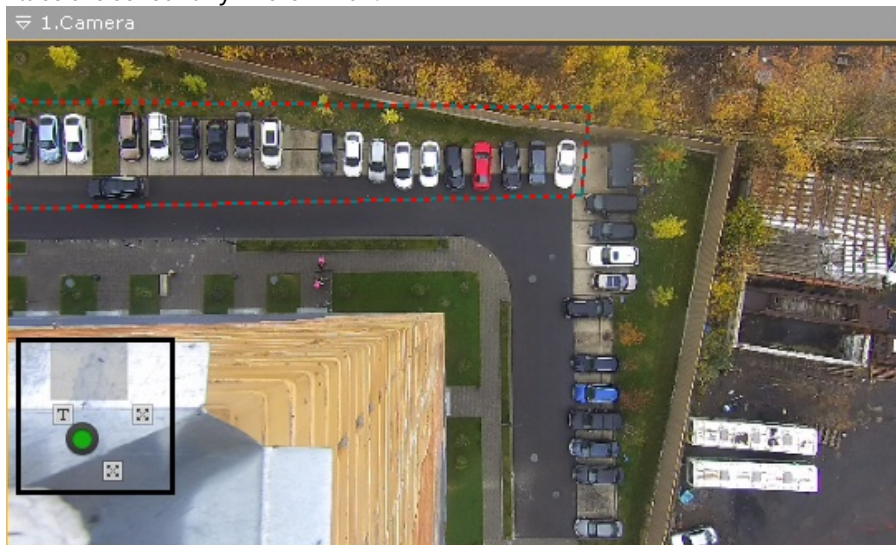

- Customize the font. To do this, press the button **T**.
- Save the layout (see [Exiting layout editing mode](#)).

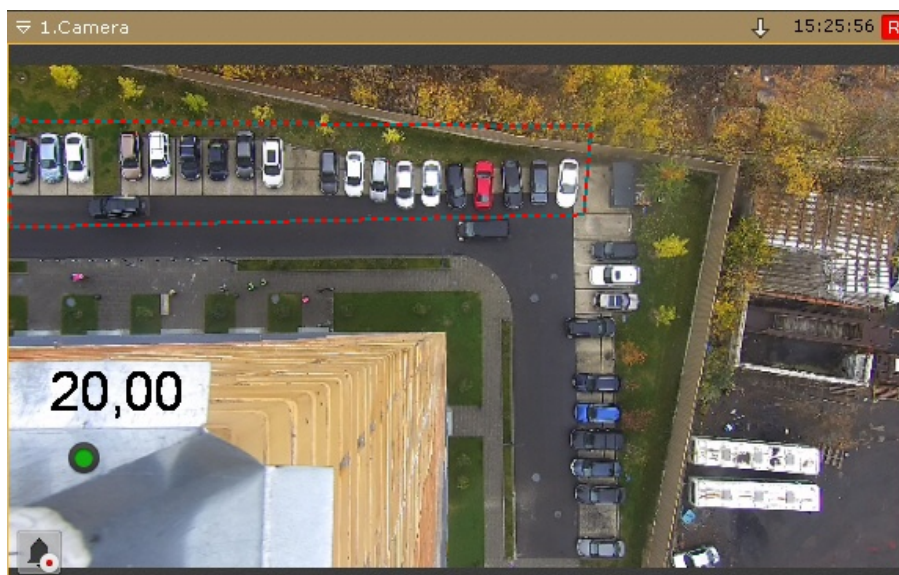

7.4.14 Fire and Smoke Detection Tools

7.4.14.1 Functions of Fire and Smoke detection

Important!

Unlike standard smoke / fire detection systems, smoke and fire software detection tools face many issues with the scene and the background image. We cannot warrant 100% smoke / fire detection. The smoke and fire detection tools are meant to increase the likelihood of detecting smoke / fire. However, there may be both false alarms and failures to detect actual fire / smoke events in the camera's FoV.

We keep improving smoke and fire detection and use machine learning based on a [Neural network](#).

If the fire / smoke detection tools does not respond to actual fire / smoke events, please record a video clip and send it to [AxxonSoft](#). We will update *Axxon Next* to refine detection. Help us train the neural network with video feeds from your scene to deliver best results for your fire security.

Note

These detection tools require Addon Neuro Pack to be installed (see [Installing DetectorPack add-ons](#)).

7.4.14.2 Camera requirements for Fire and Smoke Detection

Please follow these recommendations for proper fire and smoke detection:

1. Use color cameras. With black and white cameras, the detection quality can be noticeably worse.
2. The video resolution must be at least 640x360.
3. FPS directly affects detection efficiency; in most cases, the default value (1 detection per 10 seconds) is sufficient to detect smoke or fire which develops in more than one minute.
4. The minimal recognized fire/smoke area depends on the particular neural network used. For a standard neural network (see [Configuring Smoke and Fire Detection Tools](#)), the fire/smoke area must occupy at least 10% of the frame.

Note

In some cases, when fire is expected to be clearly visible, the fire area may be sufficient at 1-3% of the FoV width / height.

5. Fire/smoke should be visually separated from the background.

Attention!

If you set a rectangular recognition area for the detection tool, the limitations apply to this area rather than to the entire frame (see [Configuring Smoke and Fire Detection Tools](#)).

[Hardware requirements for neural analytics operation](#)

7.4.14.3 Configuring Smoke and Fire Detection Tools

[Camera requirements for Fire and Smoke Detection](#)

To configure smoke (fire) detection tool:

1. If a camera supports multistreaming, select the stream for which detection is needed (**1**). Selecting a low-quality video stream allows reducing the load on the Server.

Smoke detection	
1	Video stream from camera Low-quality video stream
▼ Other	
2	Decoder mode CPU
3	Frame processing period (sec) 10
4	Mode CPU
5	Neural network file
6	Number of measurements in a row to trig 5
7	Sensitivity 33

2. Select a processing resource for decoding video streams (**2**). When you select a GPU, a stand-alone graphics card takes priority (when decoding with NVidia NVDEC chips). If there's no appropriate GPU, the decoding will use the Intel Quick Sync Video technology. Otherwise, CPU resources will be used for decoding.

3. Set the interval between the processes frames in seconds (**3**). The value should be in the [1;30] range.

Note

The default values (5 frames and 10 seconds) indicate that the tool will analyze one frame every 10 seconds. When smoke (fire) is detected in 5 frames, the tool will trigger.

4. Select the processor for the neural network — CPU, one of GPUs or a [IntelNCS](#) (**4**).

Attention!

It may take several minutes to launch the algorithm on an NVIDIA GPU after you apply the settings.

Attention!

If you specify other processing resource than the CPU, this device will carry the most of computing load. However, the detection tool will consume CPU as well.

5. Select a neural network file (**5**). The following standard neural networks for different processor types are located in C:\Program Files\Common Files\AxxonSoft\DetectorPack\NeuroSDK:

smoke_movidius.ann	Smoke detector / IntelNCS
smoke_openvino.ann	Smoke detector / CPU
smoke_original.ann	Smoke detector / GPU
fire_movidius.ann	Fire detector / IntelNCS
fire_openvino.ann	Fire detector / CPU
fire_original.ann	Fire detector / GPU

Enter full path to a custom neural network file into this field. This is not required if you use standard neural networks which are selected automatically.

Note

For correct neural network operation under Linux, place the corresponding file in the /opt/AxxonSoft/AxxonNext/ directory.

6. Set the minimum number of frames with smoke (fire) for triggering the tool (**6**). The value should be in the [5;20] range.
7. You can experiment with the sensitivity of the tool (**7**). The value must be in the range [1; 99]. The preview window displays the sensitivity scale of the detection tool. It is color-coded as follows:
- Green - smoke (fire) not detected.
 - Yellow - smoke (fire) detected, but not enough to trigger the tool.
 - Red - smoke (fire) detected.

If you increase the sensitivity value, you have more alerts (red scale).



8. By default, the detection is performed over full image area. In the preview window, you can set several detection zones by their anchor points as follows:
 - a. Right-click anywhere in the Preview window.

Detection area (polygon)

Detection area (rectangle)

- b. Select **Detection area (rectangle)** for a rectangular zone. If you specify a rectangular area, the detection tool will work only within its limits; the rest of the FOV will be ignored.
- c. Select **Analytics Area (polygon)** to set one or several polygonal zones. If you specify one or several polygonal areas, the detection tool will process the entire FOV while the remaining part of the FOV will be blacked out.

Note

You can configure detection zones similarly to privacy masks in scene analytics (see [Setting General Zones for Scene Analytics](#)).

Important!

You can use trial and error method to decide which type of detection area (rectangular or polygonal) is more effective in your case. Some neural networks give better detection with rectangles while others are better with polygons.

7.4.15 Equipment detection tool (PPE)

7.4.15.1 Functions of the Equipment detection tool (PPE)

The Equipment detection tool (PPE) locates individuals wearing no personal protective equipment within the area where it's required, or individuals wearing improperly applied PPE.

Attention!

We recommend you to apply detection in gateway mode: an employee entering a zone where equipment or PPE is required should wait until the detection is complete (normally 5–10 seconds).

For detection tool's operation, you need at least two separate neural networks:

- a segmenting network structures up an image of a human body (locates head, shoulders, arms, hands, thighs, legs and feet);
- a classifying network detects equipment (PPE) on a specified body part, and checks if it's properly applied.

Note

The equipment detection tool (PPE) requires Addon Neuro Pack to be installed.

7.4.15.2 Camera requirements for the equipment detection tool (PPE)

For equipment detection tool (PPE) operation, a camera must match the following requirements:

1. To apply detection in gateway mode (see [Functions of the Equipment detection tool \(PPE\)](#)), you should have no less than 3 FPS; in continuous mode, the minimal value increases up to 8 FPS.
2. Pixel density must be at least 170 pixels per meter. The equipment element of interest is clearly visible.
3. Approximate minimum pixel dimensions of equipment elements:
 - a. Upper body: 75 x 100
 - b. Legs: 75 x 105
 - c. Head: 60 x 65
 - d. Hands: 65 x 60
 - e. Feet: 45 x 40
 - f. Combined set 165 x 295
4. Scene lighting must not alter color of equipment elements.
5. Average illumination in scenes with equipment detection must not drop below 200 lux.

Attention!

We cannot guarantee normal operation of PPE detection with a fisheye camera.

[Hardware requirements for neural analytics operation](#)

7.4.15.3 Configuring equipment detection tool (PPE)

[Hardware requirements for neural analytics operation](#)

To set up the equipment detection tool (PPE), do the following:

1. If the camera supports multistreaming, select the stream for which detection is needed (**1**).

Equipment detection (PPE)	
1	Video stream from camera Low-quality video stream
▼	Other
	Classification network 1 file
	Classification network 2 file
2	Classification network 3 file
	Classification network 4 file
	Classification network 5 file
3	Decoder mode CPU
4	Min person height 0.01
5	Min person width 0.01
6	Mode CPU
7	Segmenting network file

2. Select one or several files for the classifying neural network (2). There must be a separate classifying neural network to recognize equipment on each body segment.
3. Select a processing resource for decoding video streams (3). When you select a GPU, a stand-alone graphics card takes priority (when decoding with NVidia NVDEC chips). If there's no appropriate GPU, the decoding will use the Intel Quick Sync Video technology. Otherwise, CPU resources will be used for decoding.
4. Set the minimum height and width of a person (4, 5) in the frame as a percentage of the frame height/width (0,15 = 15%). Objects which are smaller than the specified size will not be detected.
5. Select the processor for the neural network - CPU, one of GPUs, or Intel processors (6, see [Hardware requirements for neural analytics operation](#)).

Attention!

It may take several minutes to launch the algorithm on an NVIDIA GPU after you apply the settings.

Attention!

If you specify other processing resource than the CPU, this device will carry the most of computing load. However, the detection tool will consume CPU as well.

6. Select the segmenting neural network file (7).

Attention!

To access the neural network, contact technical support <https://support.axxonsoft.com/>.

7. Select the **Mask** checkbox to display body segments in the preview window (8).

Advanced detection settings		
8	Mask	No
9	Number of frames for analysis	1000
10	Number of measurements in a row to trigger detection	3
11	One event per PPE element	Yes

8. Set the interval between the analyzed frames - **Number of frames for analysis** - in milliseconds (9). The value should be within the range of 30 – 10,000.
9. Set the minimum number of frames containing people with no PPE for triggering the tool - **Number of measurements in a row to trigger detection** (10). The value should be within the range of 2 – 20.

Attention!

To apply detection in gateway mode (see [Functions of the Equipment detection tool \(PPE\)](#)), we recommend you to use the detection tool set to default delay (1000 ms) and 3 frames for output.

To apply detection in continuous mode, set the delay to no more than 250 ms, and the number of frames to no less than 6.

10. By default, each equipment element's triggering occurs once during a continuous tracking of a human object. You can set triggering to multiple by setting the **One Event per Equipment Element** parameter to **No** (10).

Note

Example. An individual not wearing a helmet appears in FoV, puts on a helmet, then puts it off. If the **One Event per Equipment Element** parameter is activated, you will have one alarm event, otherwise two.

11. In the preview window, you can set the detection zones with the help of anchor points much like privacy masks in Scene Analytics (see [Setting General Zones for Scene Analytics](#)). By default, the entire FoV is a detection zone.
12. Click **Apply**.

Equipment detection tool (PPE) is now configured.

The equipment detection tool (PPE) triggers an alarm when a person not wearing required equipment (PPE) on specified body parts, or wearing inappropriate equipment, appears in FoV.



7.4.16 Person-based privacy masking

7.4.16.1 Person-based privacy mask functions

The privacy mask hides selected parts of a human body from viewing on video.

A segmenting network structures up an image of a human body: locates head, shoulders, arms, hands, thighs, legs and feet.

Note

Person-based privacy masking requires the Add-on Neuro Pack to be installed

7.4.16.2 Camera requirements for privacy masking

For person-based privacy masking operation, a camera must match the following requirements:

1. Frame rate is no less than 12 FPS.
2. Pixel density must be at least 170 pixels per meter.
3. Average illumination in scenes with privacy masking must not drop below 200 lux.

Attention!

We cannot guarantee normal operation with a fisheye camera.

[Hardware requirements for neural analytics operation](#)

7.4.16.3 Person-based privacy mask configuration

To configure privacy masking, do the following:

1. If the camera supports multistreaming, select the stream for which detection is needed (1).

Person-based privacy masking	
1	Video stream from camera Low-quality video stream
▾ Other	
	Body No
2	Decoder mode CPU
	Foot No
	Forearms No
	Hands No
	Head Yes
	Hips No
3	Mode CPU
4	Segmenting network file
	Shin No
	Shoulders No
▾ Advanced detection settings	
5	Number of frames for analysis 1000
6	Number of measurements in a row to trigger detection 3

2. Select a processing resource for decoding video streams (2). When you select a GPU, a stand-alone graphics card takes priority (when decoding with NVidia NVDEC chips). If there's no appropriate GPU, the decoding will use the Intel Quick Sync Video technology. Otherwise, CPU resources will be used for decoding.
3. Select the processor for the neural network - CPU, one of GPUs, or Intel processors (3, see [Hardware requirements for neural analytics operation](#)).

Attention!

If you specify other processing resource than the CPU, this device will carry the most of computing load. However, the detection tool will consume CPU as well.

4. Select the segmenting neural network file (4).

Attention!

To access the neural network, contact technical support <https://support.axxonsoft.com/>.

5. Set the interval between the analyzed frames - **Number of frames for analysis** - in milliseconds (5). The value should be within the range of 30 – 10,000.
6. Select **Yes** for all body parts that should be masked within FoV.
7. Click **Apply**.

Privacy mask configuration is now complete. Selected body parts of all individuals within FoV will be hidden from view.

7.4.17 Pose detection tools

7.4.17.1 Functions of Pose Detection

Pose detection is powered by neural networks. The operational requirements for Pose detection tools are the same as applied to neural trackers and neural filters.

Pose detection tool types are listed in the following table.

Detection Tool	Detection tool description
Man down detection	Triggers alarm upon detection of a prostrate human within the scene.
Sitting person detection	Triggers alarm upon detection of a sitting human.

Hands up detection	Triggers alarm upon detection of a human raising one or two hands. A hand is treated as raised if the arm is parallel to the backbone.
Active shooter detection	Triggers alarm upon detection of a human with an arm parallel to the ground.
People masking	People Masking is a non-triggering detection tool that blocks individuals' bodies with solid color.
People counter	This detection tool counts individuals within a specified area. Triggering occurs on exceeding a specified limit.
Handrail holding detection	Triggers an alarm if an individual in a specified part of the scene does not hold any of specified handrails.
Close-standing people detection	Triggers an alarm if the distance between two separate individuals in scene falls below a specified minimum value.

Note

Pose detection tools require Addon Neuro Pack to be installed (see [Installing DetectorPack add-ons](#)).

7.4.17.2 Camera requirements for pose detection

For pose detection, a camera must match the following requirements:

1. Minimum resolution is at least 640x360 pixels.
2. Frame rate must be no less than 6 FPS.
3. Objects must be visually separated from the background as well as from each other.
4. Camera is mounted in no less than 3 meters above the ground.
5. An object must occupy no less than 5% of the FoV width / height.

Attention!

We cannot guarantee normal operation of pose detection with a fisheye camera.

[Hardware requirements for neural analytics operation](#)

7.4.17.3 Configure Pose Detection

7.4.17.3.1 Setting up common parameters for pose detection tools

To configure common parameters for pose detection tools, do as follows:

1. Select the **Pose Detection** object.

Pose detection	
Object identification	
Enable	Yes
Name	Pose detection
Object features	
1 Record objects tracking	Yes
2 Video stream from camera	Low-quality video stream
Other	
3 Decoder mode	CPU
4 Frame processing period (msec)	1000
5 Mode	CPU
6 Neural network file	

2. By default, video stream's metadata are recorded in the database. You can disable it by selecting **No** in the **Record object tracking** list (**1**). Video decompression and analysis are used to obtain metadata, which causes high Server load and limits the number of video cameras that can be used on it.
3. If a camera supports multistreaming, select the stream for which detection is needed (**2**). Selecting a low-quality video stream allows reducing the load on the Server.
4. Select a processing resource for decoding video streams (**3**). When you select a GPU, a stand-alone graphics card takes priority (when decoding with NVidia NVDEC chips). If there's no appropriate GPU, the decoding will use the Intel Quick Sync Video technology. Otherwise, CPU resources will be used for decoding.
5. Set the interval between the analyzed frames in milliseconds (**4**). The value should be within the range of 30 – 10,000.

Attention!

With static individuals in scene, set the interval to no more than 500 ms. With moving individuals in scene, less than 250 ms is recommended.

The less the interval, the higher accuracy of pose detection for the cost of CPU load. For 1000 ms interval, accuracy will be no less than 70%.

We recommend that you use trial and error method to set the appropriate value.

6. Select the processor for the neural network - CPU, one of GPUs, or **Intel NCS** (**5**, see [Hardware requirements for neural analytics operation](#)).

Attention!

If you specify other processing resource than the CPU, this device will carry the most of computing load. However, the detection tool will consume CPU as well.

Attention!

It may take several minutes to launch the algorithm on an NVIDIA GPU after you apply the settings.

Attention!

Man-down or sitting-pose detection accuracy may depend on the particular processor. If another selected processor gives less accurate results, set the detection parameters empirically, and configure scene perspective.

- By default, the entire FoV is an area for detection. If necessary, you can specify the areas for detection and skip areas in the preview window. To set an area for detection, right click anywhere on the image, and select a desired area.

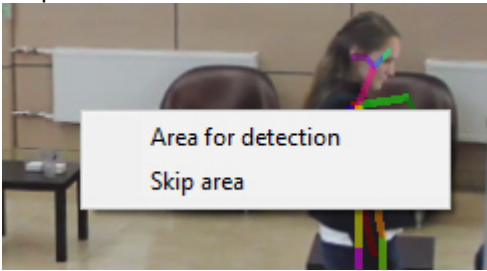

Note

The areas are set the same way as for the Scene Analytics (see [Configuring the Detection Zone](#)).

This is how it works:

- if you specify areas for detection only, no detection will be performed in the rest of FoV.
 - if you specify skip areas only, the detection will be performed in the rest of FoV.
- Select a neural network file (6).
 - Select the desired detection tool.

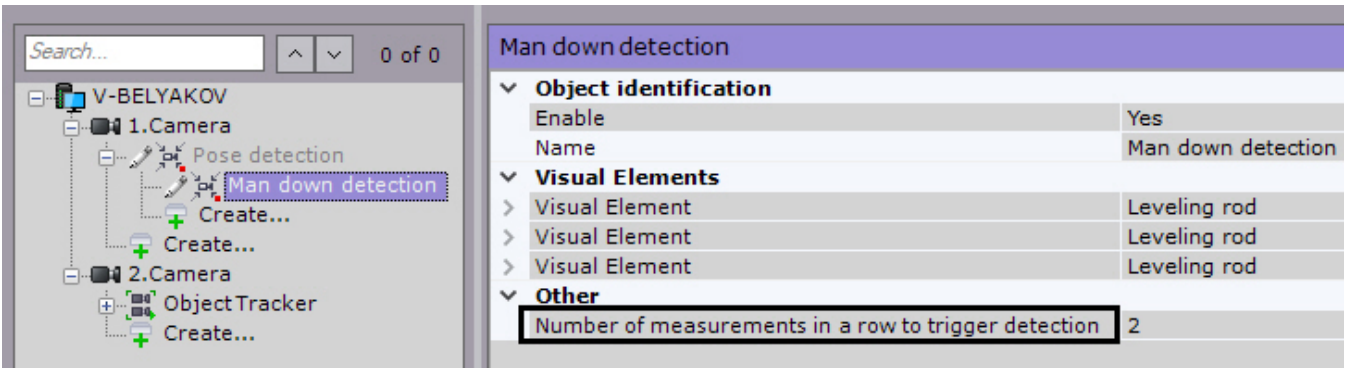

- Set the minimum number of frames with a human in a pose of interest for triggering the tool.

Note

The default values (2 frames and 1000 milliseconds) indicate that the tool will analyze one frame every second. When a pose is detected in 2 consequent frames, the tool will trigger.

Note

This parameter is not used for masking settings.

- Click **Apply**.

7.4.17.3.2 Specific settings for People Counter

The People Counter uses pose detection metadata.

A macro triggers when the number of individuals in FoV matches pre-defined conditions (see [Configuring filters for event-driven macros](#)).

Note

Unlike the Multiple Objects detection tool (see [Settings Specific to Multiple objects](#)), the counter generates events of just one type, namely triggering.

As opposed to Neuralcounter (see [Configuring a Neuralcounter](#)), People Counter counts just people.

To set up People Counter, do the following:

1. Set common parameters (see [Setting up common parameters for pose detection tools](#)).

People counter	
<ul style="list-style-type: none"> Other 	
1 Alarm when value	In range
2 End value of alarm range settings	100
3 Event interval	1
Number of measurements in a row to trigger detection	3
4 Start value of alarm range settings	5



2. Set the visitor counter triggering condition:
 - a. Set the condition polarity, i.e. triggering when the number of visitors in the specified area is within the set range, or out of the range (**1**).
 - b. Set the range of number of visitors in FoV (**2, 4**).
3. Set an interval between two consecutive triggering of the visitor counter when the number of individuals in FoV continuously matches the condition(s) (**3**).
4. In the preview window, you can set detection zones with the help of anchor points much like privacy masks in Scene Analytics. By default, the entire FoV is a detection zone (see [Setting General Zones for Scene Analytics](#)).

7.4.17.3.3 Specific settings for the Man Down detection tool

[Setting up common parameters for pose detection tools](#)

To detect a lying pose, you have to configure scene perspective first.

Please follow the steps below:

1. Select a detection tool, and click  in the preview window.
2. Set the size of the same human figure in different areas of FOV. To create a leveling rod, left-click on the video image to add two anchor points. You should set no less than three leveling rods. The leveling rod height must correspond to a human figure placed in the same point of the scene. You can resize the rod by stretching its anchor points , or move it on screen by [dragging and dropping](#).



Attention!

When setting up leveling rods, please make sure that the following conditions are met:

- all rods have different height;
- all rods must be based on the same plane (for example, floor);
- in complex scenes where detection accuracy is crucial, we recommend you to add more than 3 rods;
- in areas where the picture is apparently distorted, place the rods in parallel to known vertical elements (doors, bookcases, etc.).

Attention!

In portrait-oriented scenes (such as store / warehouse aisles, etc.), set the rods in triangles.

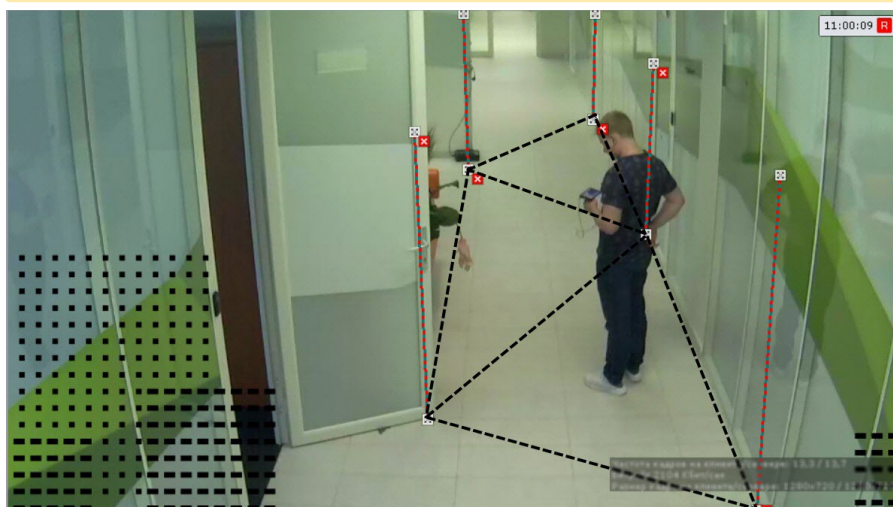
**Note**

For your convenience, you can click the  button to freeze the video. To unfreeze, click the button once more.

Note

To delete a rod, click the  button.

- Click **Apply** button.

7.4.17.3.4 Specific settings for the Sitting person detection tool

Setting up common parameters for pose detection tools

To detect a sitting pose, you have to configure scene perspective first.

Please follow the steps below:

- Select a detection tool, and click  in the preview window.
- Set the size of the same human figure in different areas of FOV. To create a leveling rod, left-click on the video image to add two anchor points. You should set no less than three leveling rods. The leveling rod height must correspond to a

human figure placed in the same point of the scene. You can resize the rod by stretching its anchor points , or move it on screen by [dragging and dropping](#).



Attention!

When setting up leveling rods, please make sure that the following conditions are met:

- all rods have different height;
- all rods must be based on the same plane (for example, floor);
- in complex scenes where detection accuracy is crucial, we recommend you to add more than 3 rods;
- in areas where the picture is apparently distorted, place the rods in parallel to known vertical elements (doors, bookcases, etc.).

Attention!

In portrait-oriented scenes (such as store / warehouse aisles, etc.), set the rods in triangles.

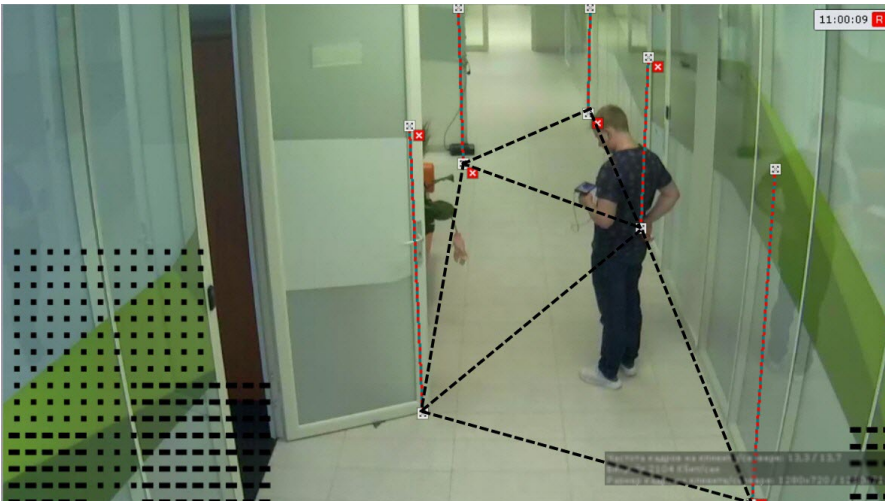

Note

For your convenience, you can click the  button to freeze the video. To unfreeze, click the button once more.

Note

To delete a rod, click the  button.

3. Click **Apply** button.

7.4.17.3.5 Specific settings for handrail holding detection

To set up a handrail holding detection tool, do the following:

1. Set common parameters (see [Setting up common parameters for pose detection tools](#)).
2. Click anywhere in the Preview window.



3. Mark one or several handrails with lines (1).

Attention!

If lens distortion makes the handrail non-linear, use several lines.



4. Set anchor points to specify an area where people must hold handrails (2).

7.4.17.3.6 Specific settings for people masking

This tool does not generate any alarms; instead, it uses posture detection metadata to mask individuals:

- on live video;
- on recorded video;
- upon exporting from Archive.

Attention!

Masking function works only for users whose role sets the **View masked video** parameter to **No** (see [Creating and configuring roles](#)).



7.4.17.3.7 Specific settings for close-standing people detection

Setting up common parameters for pose detection tools

By default, the Close-Standing People detection tool triggers when bounding boxes around individuals collide.

You can set another triggering distance by adjusting perspective:

Attention!

For portrait-oriented scenes (such as corridors, warehouse aisles, etc.) perspective adjustment is a must.

1. Select a detection tool, and click  in the preview window.
2. Set the size of the same object in different areas of the field of view. To create a calibration length, left-click within the video image in the viewing tile and add two anchor points. Set at least three calibration lengths. You can resize the length

by stretching its anchor points . You can move it on screen by [dragging and dropping](#).



Attention!

Leveling rods should:

- a. not be located on the same line;
- b. have different height.

Note

For your convenience, you can click the  button and configure the mask on a still frame / snapshot. To undo, click this button again.

Note

To delete it, click the  button.

3. Enter a triggering distance value (1) in meters into the **Distance Sensitivity** field. The detection tool will trigger if the current distance becomes equal or less than this value.

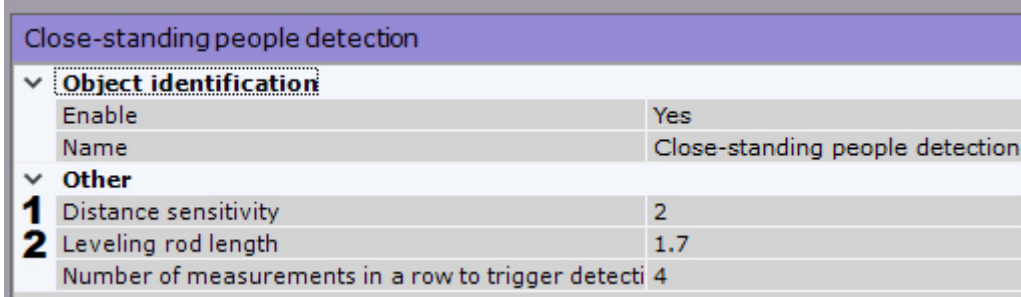

4. Enter the height (in meters) of the leveling rod into the **Leveling Rod Height** field (2).

7.4.18 Retail Analytics

7.4.18.1 Functions of retail analytics

Name of a Detection Tool object	Detection description
Queue detection	Triggers if the specified number of people in the queue is exceeded
Visitors counter	This detector monitors the number of visitors within the protected area, and triggers if the specified count is exceeded.

7.4.18.2 Camera requirements for queue detection

The following table contains the requirements for cameras used by the queue detection tool:

Camera	<ul style="list-style-type: none"> • Resolution: 360 x 288 (CIF1) to 720 x 576 (CIF4) pixels; larger images are scaled down to CIF4. • Frames per second: 6 or more • Color: color or greyscale. • No camera jitter is allowed.
Illumination:	<ul style="list-style-type: none"> • Best recognition results are achieved under moderate illumination. If the scene is under- or over-illuminated, the recognition accuracy may drop down. • Sharp changes in illumination may lead to improper operation of analytics.

Scene and viewing angle:	<ul style="list-style-type: none"> Vertically downward position is the best for the purpose. The closer to vertical, the more accurate counting. Camera FOV dimensions: min. 3 x 3m (6 x 6 humans), optimal 4 x 4m (8 x 8x humans), max. 8 x 8m (16 x 16 humans). The background must be primarily static and not undergo sudden changes. Reflective surfaces and harsh shadows from moving objects can affect the quality of analytics. Leafage, TV screens or any periodic object movement in the background may cause analytics glitches.
Images of objects within the scene:	<ul style="list-style-type: none"> Image quality: the image must be clear and sharp with no visible compression artifacts. Dimensions of a human in scene: bounding rectangle has to occupy 0.25 to 10 percent of the frame area.

7.4.18.3 Camera requirements for Visitor Counter operation

The following table contains the requirements for cameras to enable the effective operation of the visitor counter:

Camera	<ul style="list-style-type: none"> Resolution: 720 x 576 (CIF4) or 360 x 288 (CIF1) pixel resolution. Using pixel resolutions higher than CIF4 do not lead to higher recognition accuracy. Frames per second: 25. Color: color camera is obligatory. No camera jitter is allowed.
Illumination:	<ul style="list-style-type: none"> Best recognition results are achieved under moderate illumination. If the scene is under- or over-illuminated, the recognition accuracy may drop down. Sharp changes in illumination may lead to improper operation of analytics.
Scene and viewing angle:	<ul style="list-style-type: none"> Vertically downward position is the best for the purpose. The closer to vertical, the more accurate counting. Camera FOV dimensions: min. 2 x 2m, optimal 4 x 4m. The background must be primarily static and not undergo sudden changes. The counting area must not contain any moving objects except for humans. Reflective surfaces and harsh shadows from moving objects can affect the quality of analytics. Leafage, TV screens or any periodic object movement in the background may cause analytics glitches. If possible, avoid obstruction of the humans by static objects such as pillars, trees, etc.
Images of objects within the scene:	<ul style="list-style-type: none"> Image quality: the image must be clear and sharp with no visible compression artifacts. Dimensions of a human in scene: the bounding rectangle must occupy 10–60 percent of the frame area.

Other requirements:

- The visitors must not move in a continuous flow; smaller groups of humans are counted correctly.

7.4.18.4 Configuring retail analytics detection tools

7.4.18.4.1 Configuring the queue detection tool

Camera requirements for queue detection

To configure the queue detection tool, do the following:

1. If a camera supports multistreaming, select the stream for which detection is needed (**1**). Selecting a low-quality video stream allows reducing the load on the Server.

Queue detection		
1	Video stream from camera	Low-quality video stream ^
	v Other	
2	Current queue size report interval	0
3	Decoder mode	CPU
4	Frame processing period (msec)	1000
5	Frame size change	1920
	Human size	10
6	Queue size	5
7	Sensitivity	0.5 v

2. Set an event transmission interval in seconds for sending data to the AxxonData report subsystem (see [Queue length report](#)) if the queue length exceeds the set limit (**2**). **Zero** value means no transmission of events.
3. Select a processing resource for decoding video streams (**3**). When you select a GPU, a stand-alone graphics card takes priority (when decoding with NVidia NVDEC chips). If there's no appropriate GPU, the decoding will use the Intel Quick Sync Video technology. Otherwise, CPU resources will be used for decoding.
4. In the **Frame processing period (msec)** (**4**) field, specify the time period in milliseconds between frames analyzed by the people counter within the area. The value should be within the range of 500 – 3000. The smaller the value of this parameter, the greater the CPU load.
5. By default, the frame is compressed to 1920 pixels on the longer side. To avoid detection errors on streams with a higher resolution, it is recommended that compression be reduced (**5**).
6. Specify the number of people to trigger the alarm when exceeded (**6**). The value should be within the range of 2 – 20.
7. Specify the detection tool sensitivity in standard units from 0 to 1 (**7**). The higher the sensitivity, the smaller the disturbances analyzed by the queue detection algorithm. Alternatively, the lower the sensitivity, the greater changes in scene are processed by the queue detection tool.

You should set the sensitivity value empirically based on the Motion Mask data displayed in the Preview window.



8. In the Preview window, you can set the detection zones with the help of anchor points much like privacy masks in Scene Analytics.

9. Click  and set the approximate size of a human. You can do so by dragging the corners of the rectangular area.



10. Click **Apply**.

The queue detection tool is now configured. When the detection tool is triggered, the following events are generated:

Camera "6. Camera". Detection "Queue detection" triggered, queue (min.: 6, max.: 6)

where min. and max. is estimated queue length.

7.4.18.4.2 Configuring the visitors counter

[Camera requirements for Visitor Counter operation](#)

Attention!

The visitor counter is better fit for producing average figures than exact values.

Attention!

We cannot guarantee correct operation of the visitors counter with fish-eye video cameras.

To configure the visitors counter:

1. If the camera supports multistreaming, select the stream to be used for detection. Select a low-quality video stream to reduce Server load **(1)**.

Visitors counter	
Name	Visitors counter
Object features	
1	Video stream from camera: Low-quality video stream
Visual Elements	
>	Visual Element: Detection area (rectangle)
>	Visual Element: Visitors entrance/exit areas
>	Visual Element: Visitors entrance/exit areas
Other	
2	Decoder mode: CPU
3	Frame size change: 1920
	Human size: 20
4	Number of people indoor: 0
5	People indoor counter: No
6	People indoor counter threshold: 10000

2. Select a processing resource for decoding video streams **(2)**. When you select a GPU, a stand-alone graphics card takes priority (when decoding with NVidia NVDEC chips). If there's no appropriate GPU, the decoding will use the Intel Quick Sync Video technology. Otherwise, CPU resources will be used for decoding.
3. By default, the frame is compressed to 1920 pixels on the longer side. To avoid detection errors on streams with a higher resolution, it is recommended that compression be reduced **(3)**.
4. By default, the detection tool outputs the *Camera. Visitor access in the direction of "Entrance"* and *Camera. Visitor access in the direction of "Exit"* events. If total footfall and visitor number control / exceeding notification is required, do the following:
 - a. Select **Yes** for the **People indoor counter** parameter **(5)**.
 - b. Enter the current number of visitors within the area **(4)**.
 - c. Set the threshold value for the visitor counter; exceeding this limit will generate the corresponding event **(6)**.
5. In the Preview window, set the detection area. It is divided to two sectors, #1 and #2. When an object moves from #2 to #1, the system treats it as entry; alternatively, #1 to #2 is treated as exit.
To configure the sectors, you can drag them by corners  or sides.



To swap sectors, just click inside one of them.

Note

To show / hide sectors in the Preview window, click the  button.

6. Click  and specify the approximate size of a human. You can do so by dragging the corners of the rectangular area.



7. Click **Apply**.

Configuration of the visitors counter is now complete.

7.4.19 Water Level Detection

7.4.19.1 Camera requirements for water level detection

To establish accurate results, please ensure the following:

1. Only color cameras are used.
2. Video resolution is no less than 640x360.
3. No glares or shadows are cast over the measurement scale.

7.4.19.2 Configuring water level detection

[Camera requirements for water level detection](#)

To configure the water level detection, do the following:

1. Select the created detection tool.

Water level detection		
1	Video stream from camera	Low-quality video stream
Visual Elements		
	Visual Element	
	Visual Element	Trigger level
	Visual Element	Trigger level
Other		
2	Decoder mode	CPU
3	Frame size change	1920
4	Mode	CPU
5	Neural network	No
6	Neural network file	
7	Visible bottom value	0
8	Visible top value	1

2. If the camera supports multistreaming, select the stream to be used for detection. Select a low-quality video stream to reduce Server load **(1)**.
3. Select a processing resource for decoding video streams **(2)**. When you select a GPU, a stand-alone graphics card takes priority (when decoding with NVidia NVDEC chips). If there's no appropriate GPU, the decoding will use the Intel Quick Sync Video technology. Otherwise, CPU resources will be used for decoding.
4. Analyzed framed are scaled down to a specified resolution **(3, 1280 pixels on the longer side)**. This is how it works:
 - a. If the longer side of the source image exceeds the value specified in the **Frame size change** field, it is divided by two.
 - b. If the resulting resolution falls below the specified value, it is used further.
 - c. If the resulting resolution still exceeds the specified limit, it is divided by two, etc.

Note

For example, the source image resolution is 2048 * 1536, and the limit is set to **1000**.

In this case, the source resolution will be divided two times (down to 512 * 384): after the first division, the number of pixels on the longer side exceeds the limit (1024 > 1000).

5. Choose a processor to run detection on **(4)**. Non-neural detection may be run on the CPU only.
6. Use the neural network if the tool fails to detect water level due to transparency of water. Please follow the steps below:
 - a. Select **Yes** for the **Neural Network** parameter **(5)**.
 - b. Select the neural network file **(6)**.
7. On the measurement scale **(7, 8)**, set the upper and lower visible limits in normal conditions.
8. Move the anchor points  in FoV:7
 - a. to set the measurement scale;





Attention!

Upper and lower limits of the measurement scale must match the actual settings (see paragraph 4).

- b. draw a line to set the upper limit for water level upon reaching which the detection tool triggers an alarm
- c. draw a line to set the upper limit for water level upon reaching which the detection tool highlights the sensor icon in the Camera Window with yellow color.

9. Click the **Apply** button.

When you have created a detection tool, you can see a sensor on the layout in the camera window.

If the sensor icon is green , the water level is lower than both critical and warning marks. If the icon is yellow , the level is somewhere between critical and warning. A red icon  means a level above critical.

You can also display numerical value of current water levels for the detector (see [Configuring display of water level detection](#)).

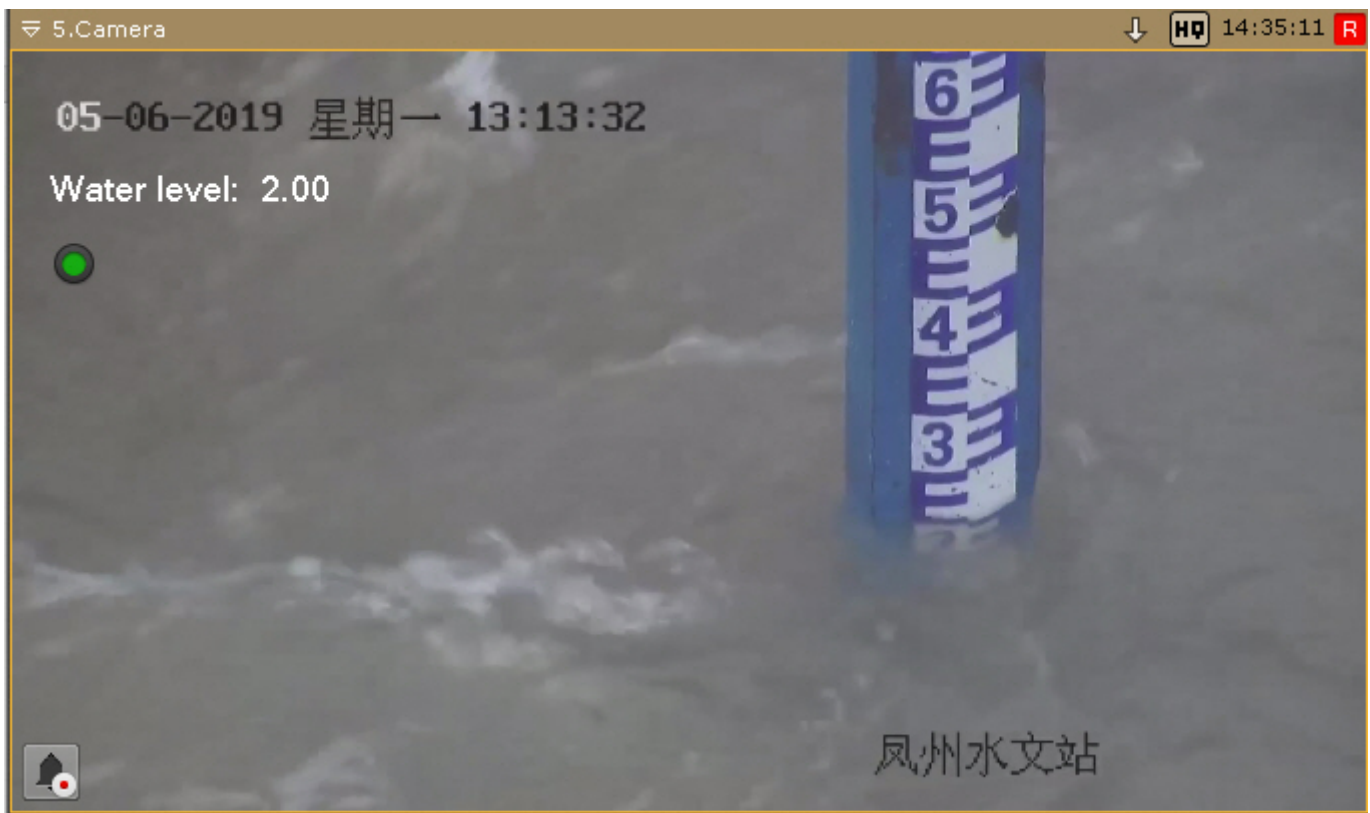

7.4.20 Embedded Detection Tools

By the date the documentation in created, the *Axxon Next* software package includes integrated analytics for multiple video cameras (see [Drivers Pack release notes](#)).

If *Axxon Next* supports built-in analytics for a device, then detectors can be created (see [Creating Detection Tools](#)).

Note

Some devices may have issues with interdependent embedded analytics. If there is already a relevant detection tool in *Axxon Next*, you can add another one, but it will not work.

7.4.20.1 Embedded Temperature Detection Tool

Axon Next supports selected models of thermal cameras with an embedded temperature detection tool ([the Drivers Pack documentation](#), **body temperature detection**). This detection tool recognizes human faces on video, and performs temperature measurement on them.

Normally, you should set up a detection tool as follows:

1. Create a detection tool (see [Creating Detection Tools](#)).
2. Using the camera manufacturer's documentation, set up the detection tool in the Axon Next VMS.

Attention!

As a rule, a camera requires specifying the temperature threshold, upon reaching which the detection tool would trigger an alarm.

3. If required, set up macros to perform pre-defined actions upon triggering the detector (see [Configuring Macros](#)).

Some cameras are capable to display a bounding box over the facial image along with corresponding temperature readings. If this option is available, it can be activated via the web interface of a particular camera.

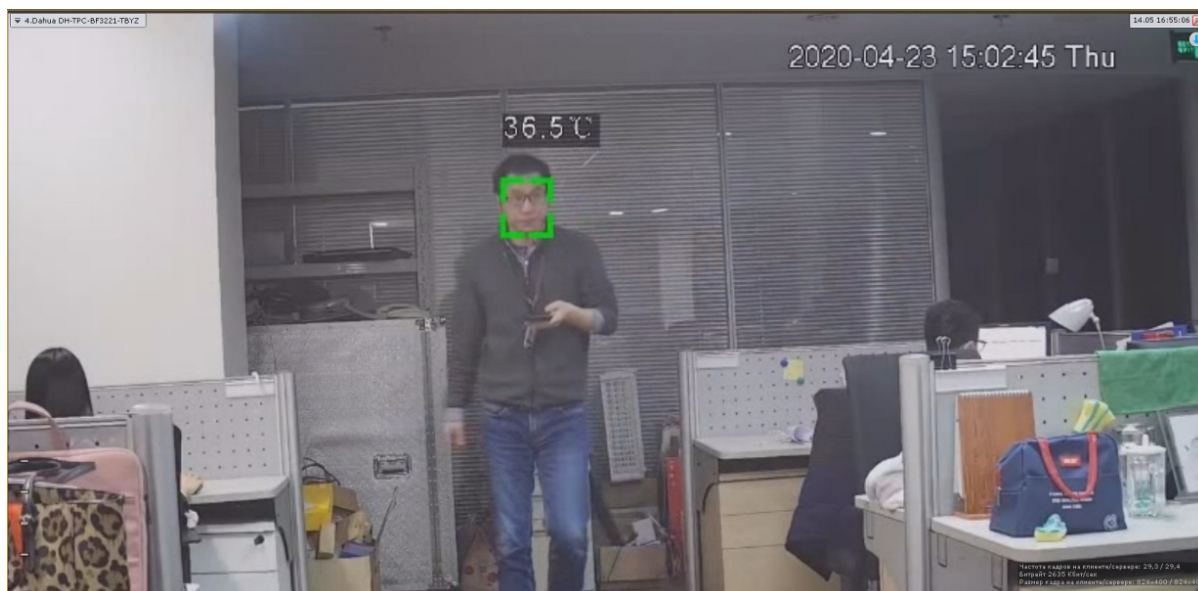

7.4.20.2 Obtaining metadata

Axon Next is also able to obtain metadata directly from certain video cameras. For example, metadata can be received from a Bosch IVA system.

To receive metadata from a Bosch IVA, you need to create an **IVA** object and select **Yes** in the **Record objects tracking** list.

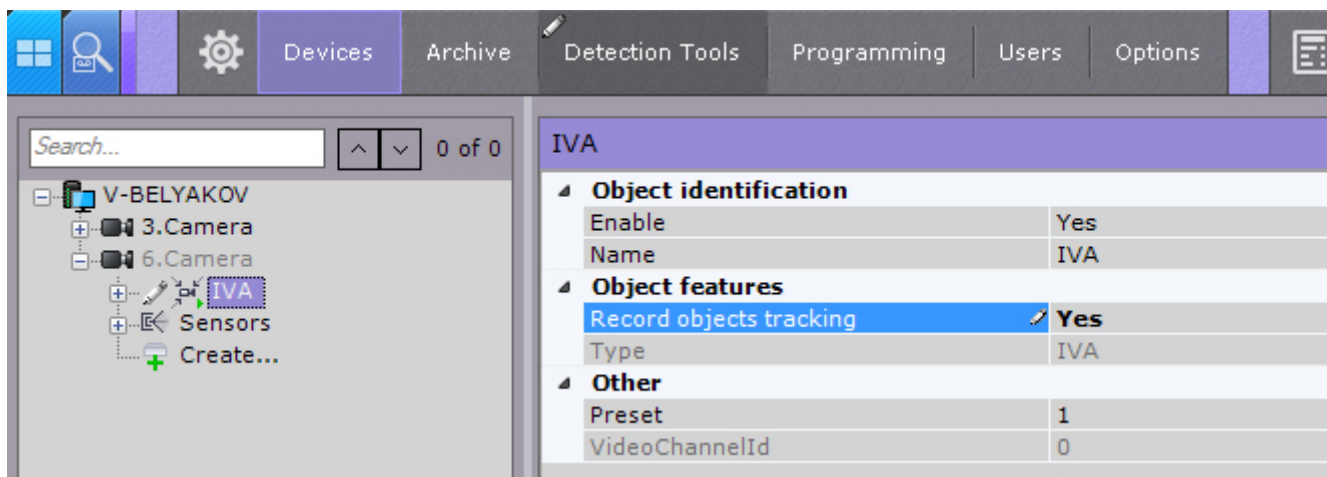

7.4.20.3 ANPR

The VMS can process ANPR data from some cameras' on-board analytics.

Note

Please contact technical support <https://support.axxonsoft.com/> for a list of cameras with this feature.

Generally, when configuring the embedded analytics you must follow official documentation for the corresponding video camera or parameter description in the *Axxon Next* interface.

Motion Mask

If the camera supports Motion Mask, then when you configure VMD, it will be displayed in the preview window.



If there is motion, but it does not exceed the threshold value (because of the detection sensitivity), the mask cells are colored green. If motion triggers VMD, the cells turn red.

7.4.20.4 AxxonSoft tracking in Axis devices

You can use analytics from AxxonSoft ([Configuring Scene Analytics Detection Tools](#)) on Axis devices.

Note

This option is available for all Axis devices on the following hardware platforms:

- MIPS (ARTPEC-4 and ARTPEC-5 CPUs)
- ARMv7 (ARTPEC-6 and ARTPEC-7 CPUs).

For full list of setup parameters, refer to the [AxxonSoft Tracker help](#).

All CPU heavy analytics and metadata generation tasks are delegated to the camera in this case.

To do this:

1. Go to the device's web interface.
2. Select the **Setup** menu (1) -> **Applications** (2).

The screenshot displays the web interface for an AXIS Q1615 Network Camera. The top navigation bar includes 'Live View | Setup | Help', with 'Setup' highlighted as '1'. The left sidebar menu shows 'Applications 2' as the active section, with 'Overview' and 'Motion Detection 3' as sub-items. The main content area is titled 'Application Packages' and contains an 'Upload Application' section with a 'Choose File' button (labeled '3') and an 'Upload Package' button (labeled '4'). Below this is a table of 'Installed Applications' with the following data:

Application	Version	Vendor	Status	License
AXIS Video Motion Detection	3.2-0	Axis Communications	Idle	None

At the bottom of the table are buttons for 'Start', 'Stop', 'Remove', and 'Log'.

3. Select the **ACAP** application (3) and click **Upload the Package** (4).

Important!

For application, contact [AxxonSoft help-desk](#). You will be given a license code that is to be registered along with camera's MAC address on [Axis website](#) in order to get the license file.

4. Go to **AxxonSoft Tracker** menu (1) -> **License**(2).

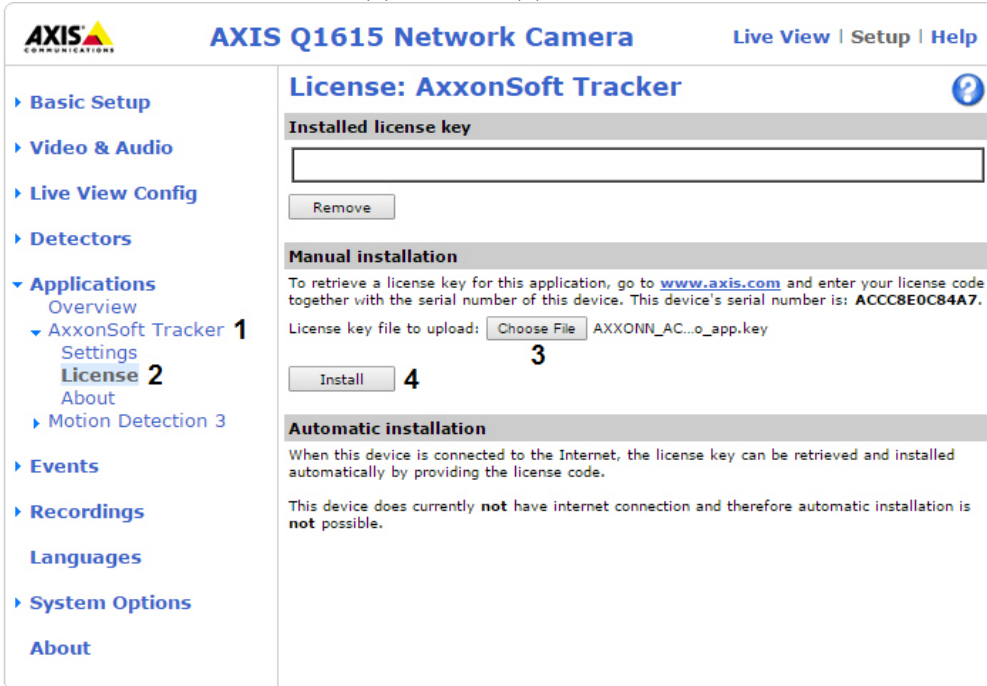

5. Select the license file (3).

6. Click **Install** (4).

7. Go to **Applications**, select the installed application (1).

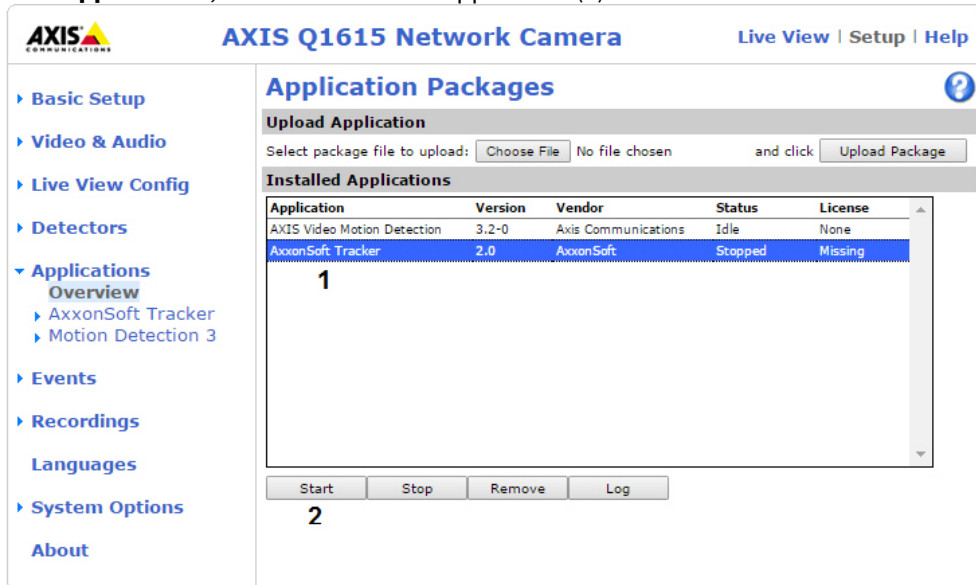

8. Click **Start** (2).

9. In *Axxon Next*, create for the corresponding camera the **AxxonSoft Onboard tracker** object.

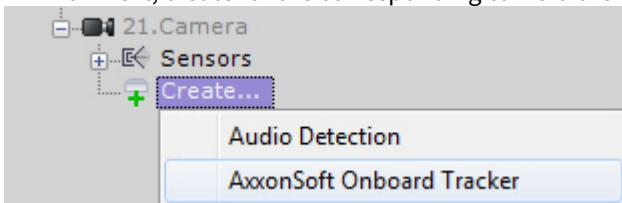

10. Configure the tracker and create the required detection tools.

Note

You can configure the **AxxonSoft Onboard tracker** object similar to the [General information on Scene Analytics](#). You cannot configure perspective for solution based on Axis devices.

7.4.21 Configuring Inputs

After becoming enabled on the **Devices** tab, the **Input** object appears on the **Detection Tools** tab (see the section [The Input Object](#)).

Check the functioning of the Input in the **Devices** tab (see the section [The Input Object](#)). The **detection properties** field in the **Detection Tools tab** duplicates the settings entered in the **Devices** tab under **Settings** and is not editable.

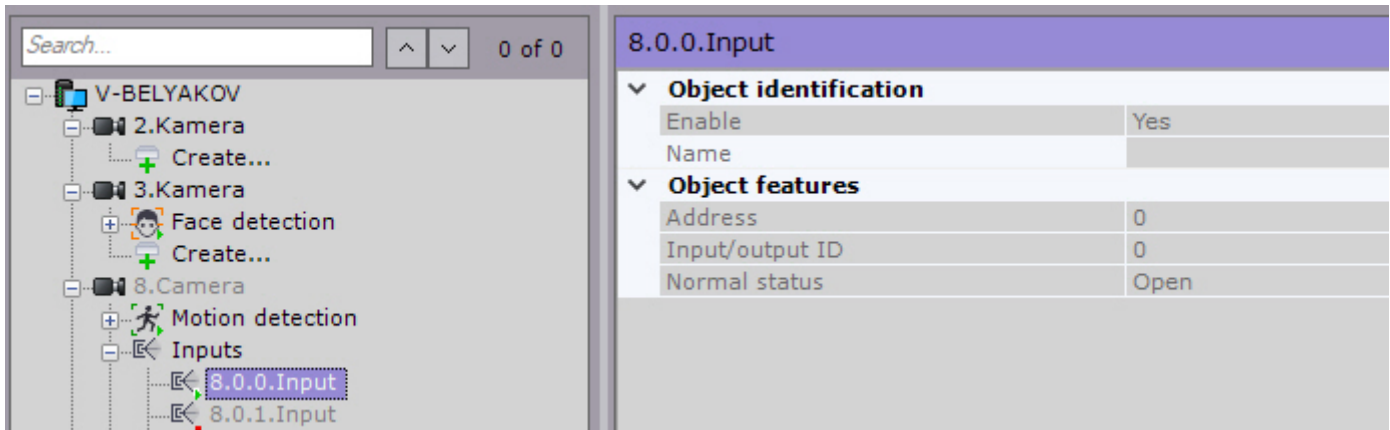

Perform the follow actions for the **Input detection tool**, on the **Detection Tools tab**:

1. Check triggering of the detection tool with the help of the Triggers ribbon (optional) (see the section [Checking the Triggering of a Detection Tool](#)).
2. Set the rules to be automatically executed when the detection tool is triggered (see the section titled [Automatic Rules](#)).

7.4.22 Mass Configure Detection Tools

You can mass configure detection tools as follows:

1. Configure one detection tool.
2. Click the button  and select detections tools the same settings should be applied to.

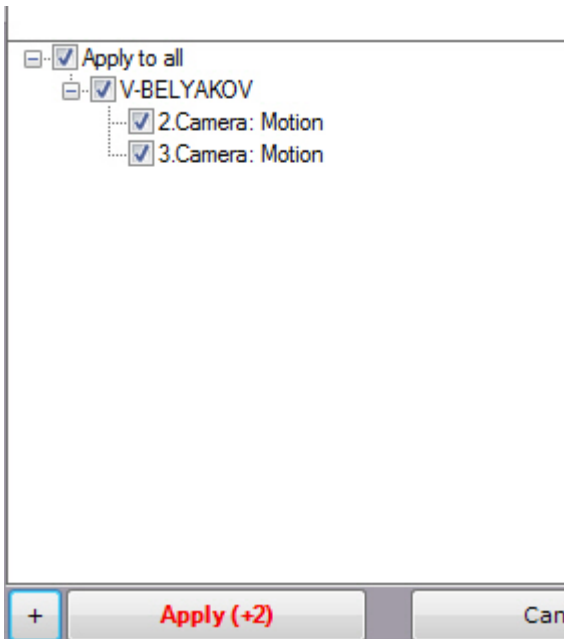
**Attention!**

Detection zones cannot be changed by bulk configuration

The list of detection tools of the same type in the current Axxon domain opens. To select multiple detection tools, hold down the Shift key, select the first and last one the settings should be applied to. Selecting any tool from highlighted ones will result in selecting them all.

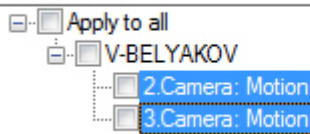

3. Click the **Apply** button.

Note

The number in brackets refers to the number of configured detection tools

7.4.23 Checking the Triggering of a Detection Tool

You can check the triggering of detection tools in the **Detection Tools tab**.

To use this option you must perform the following steps:

1. In the Detection Tools list, highlight the detection tool object whose triggering you need to check.

Attention!

The Detection Tool object should be enabled and configured

2. Produce an event whose occurrence should trigger the detection tool: motion in the frame, turning the video camera, providing sound to an audio device, etc.
3. If the detection tool is configured correctly, video image frames from the video camera corresponding to the detection tool will be displayed on the trigger ribbon with the time they were received indicated.

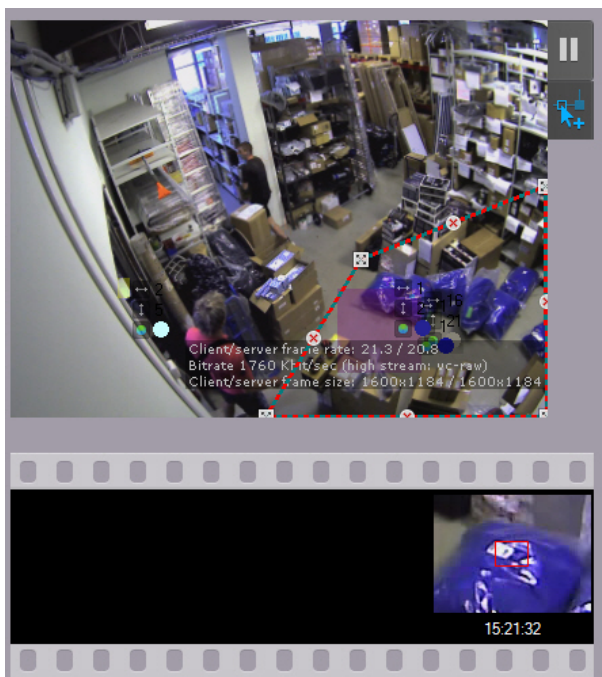

VMS checks the on / off status of detection tools when they triggered and stopped. Not applicable to detection of: quality loss, position change, disappearance of an object, motion stop and ANPR.

After the end of triggering, you get the **Finished** message.



Checking the triggering of a detection tool is now complete.

7.4.24 Automatic Rules

Automatic rules are basic macros: particular actions that are performed when a detection tool is triggered (see [Configuring Macros](#)). One or multiple automatic rules can be set for each detection tool.

The interface window for configuring automatic rules is shown when any detection tool is selected.

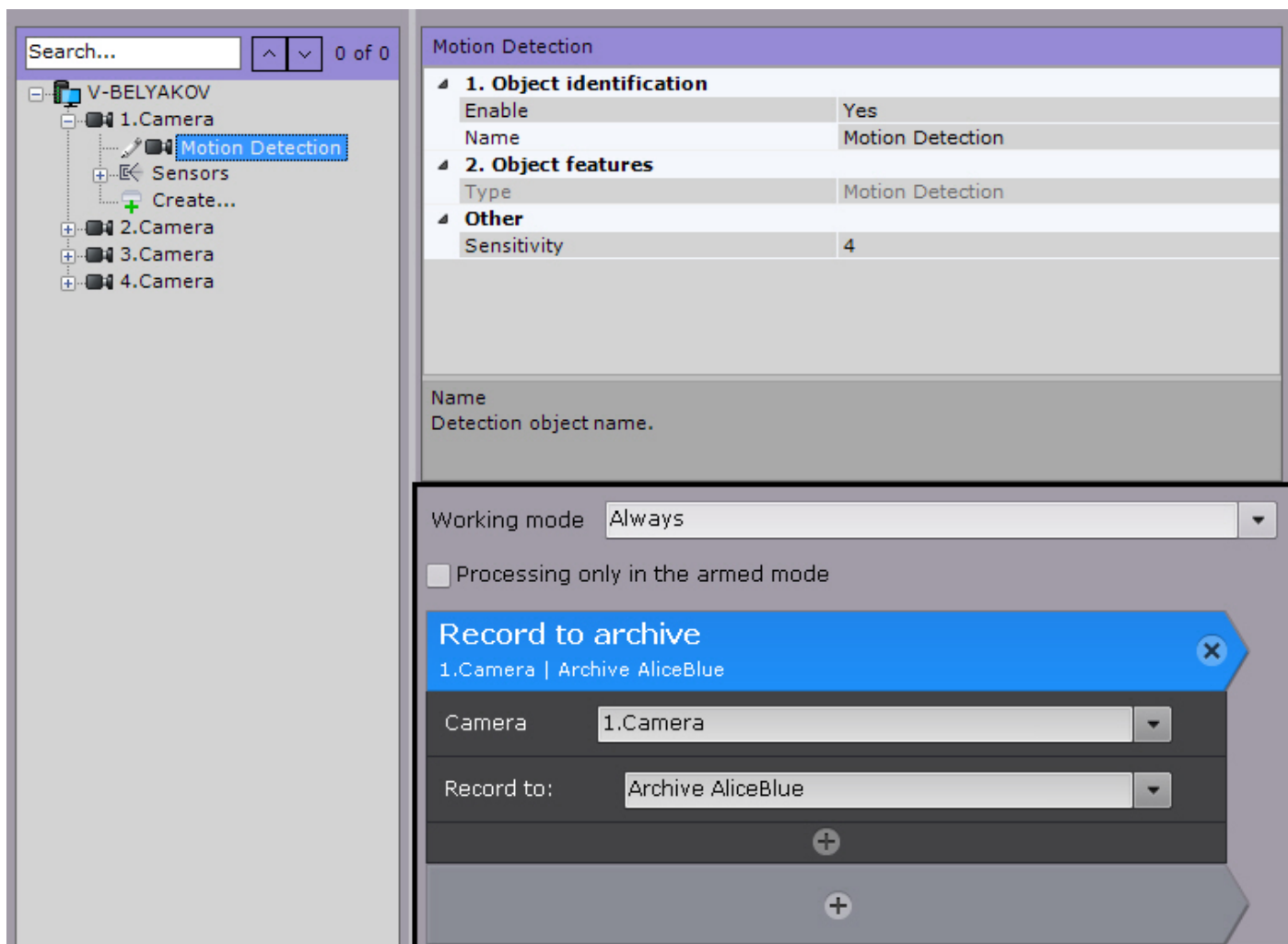

Configuring automatic rules and their mode of operation is the same as configuring macros (see [Configuring Macros](#)). Created automatic rules are displayed in the corresponding list under the **Programming** tab.

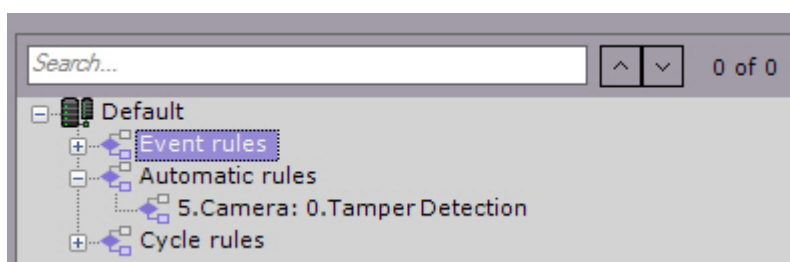

Note

When you create the [Record to archive](#) automatic rule, the recording stops when VMD (see [Configuring Scene Analytics Detection Tools](#)) triggering stops

7.5 Configuring Macros

7.5.1 General information about the macros

Macro is a tool intended for configuring system responses to events. System response may involve one or several different actions.

Attention!

You can apply macros within a single Axxon domain only. Macro conditions and actions cannot include objects from another Axxon domain.

You can create and edit macros in the **Programming** tab.

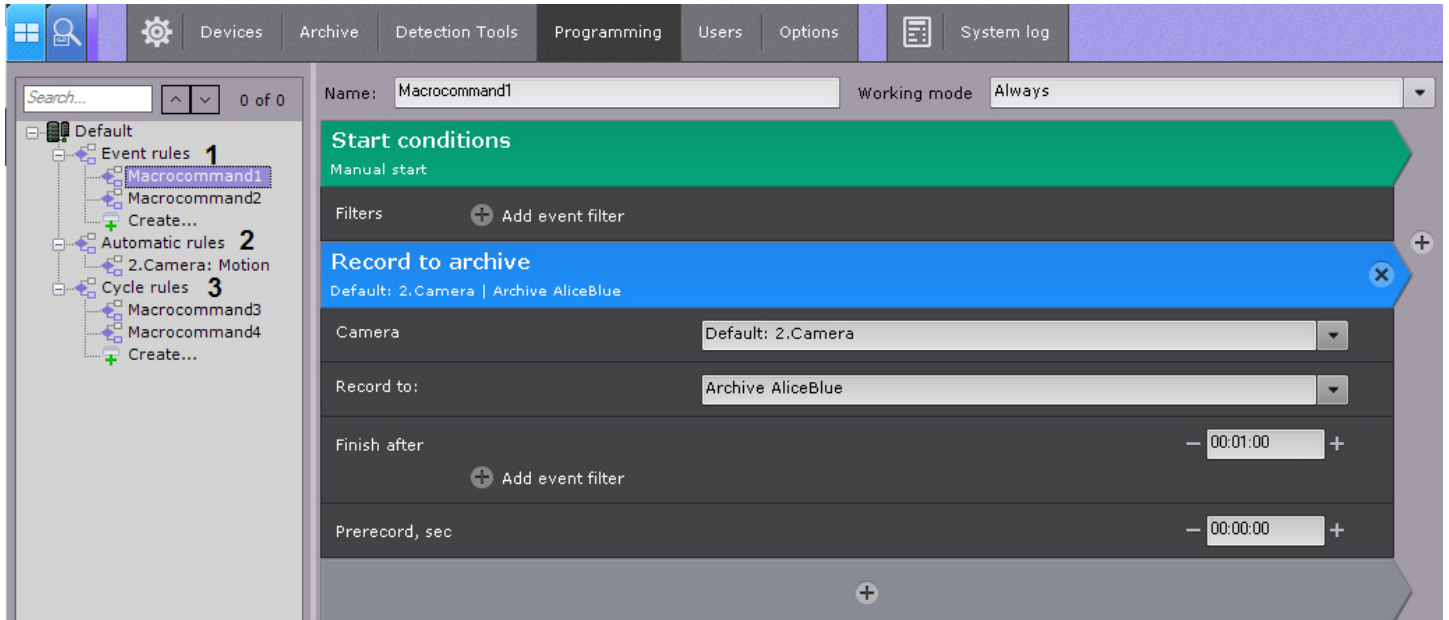

Macros can be of 3 types:

1. Event-driven (1). These macros can be run automatically on detection / event or initiated by the user. When triggered, the commands in the macro are executed once.
2. [Automatic Rules](#) (2).
3. Cyclic (3). Cyclic macros are run on the first Server in the Axxon domain (alphabetical order) available at the time of launching the macro. Cyclic macros are executed immediately after you save them unless they have been created outside the time schedule for commands (see [Create Macros](#)). After completing all the commands, the macro is automatically restarted. Cyclic macros cannot be started by the user. Additionally, a cyclic macro can be launched at a specified time interval, or at a random moment within the specified time interval. When triggered, the commands in such a macro are executed once.

Attention!

If an event occurs while the cyclic macro is busy, it is skipped.

If an event occurs while the event-driven macro is busy, it is processed as configured.

Unless the macro has standby commands (see [Wait for event](#), [Wait for timeout](#), [Wait till previous action finishes](#)), all commands are performed simultaneously.

7.5.2 Create Macros

To create a macro, click the **Create** button in the list.

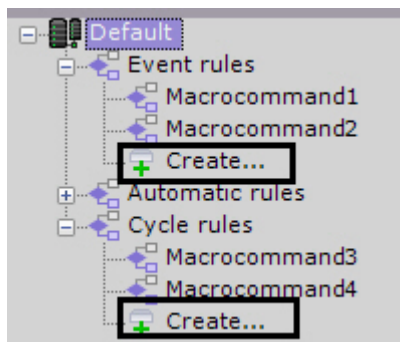

Then do as follows:

1. Enter the name of the macro (1).

2. Select the macro triggering mode (2):

Mode	Event-driven	Cyclic
Newer	Manual execution only (see Working with Dialog Board).	Disabled, manual execution is possible
Always	Always on	Always on
Time time schedule	Runs within the selected time schedule (see Creating schedules). Initiated by the user at any time.	Runs within the specified time schedule..

3. If you need to include a macro in the control menu on the current layout, select the corresponding check box (3, see [Macros control](#)).
4. To configure event-driven macros, click and select one or more trigger events (4, see [Configuring filters for event-driven macros](#)).

Note

To delete an event from the filter, click the  button.

5. Add one or more actions into the macro (5). Click the  button to do this. When the macro starts, all actions are performed simultaneously.

Note

To delete an action, click the  button.

Note

To hide the start conditions and action for the macro, click the action name.

6. A cyclic macro can be launched at a specified time interval, or at a random moment within the specified time interval. To configure this action, do as follows:
 - a. In the **Heartbeat Interval** field, specify a time interval in HH:MM:SS format (1). For example, if you set the interval to 8 hours and leave the **Random** checkbox (see 5b) unselected, the macro will be launched every 8 hours. The macro will be launched according to cycle settings even if the actions from its previous launch are not complete. In this case, several instances of the same macro will be executed simultaneously.

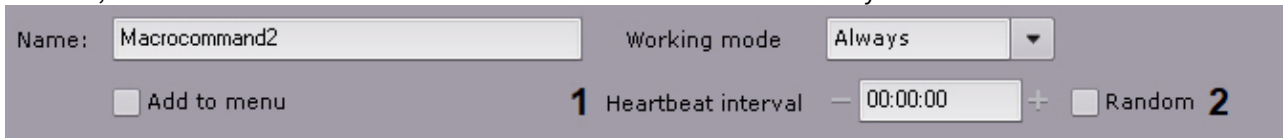

- b. In the **Launching Interval** field, specify a time interval in HH:MM:SS format (1). For example, if you set the interval to 8 hours and leave the **Random** checkbox (see 6b) unselected, the macro will be launched every 8 hours.

Attention!

If the macro is linked to a time schedule, and the random moment falls out of schedule, no launching occurs.

7. To save the macro, click the **Apply** button.

Macros configuration is complete. Created macro are listed. If the macro is disabled (**Never** mode), it is grayed out.

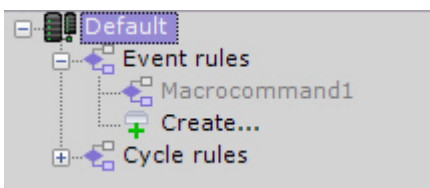

You can copy macro commands. To do it, follow the steps below:

1. Select the macro to copy.
2. Click **Create**.

This creates a new identical macro.

Note

To create an empty macro command with no parameters specified, select any of the common macros' groups, and click **Create**.

To remove a macro, select it in the list and click **Remove**.

7.5.3 Configuring filters for event-driven macros

When you create event-driven macros, you can select one or more trigger events.

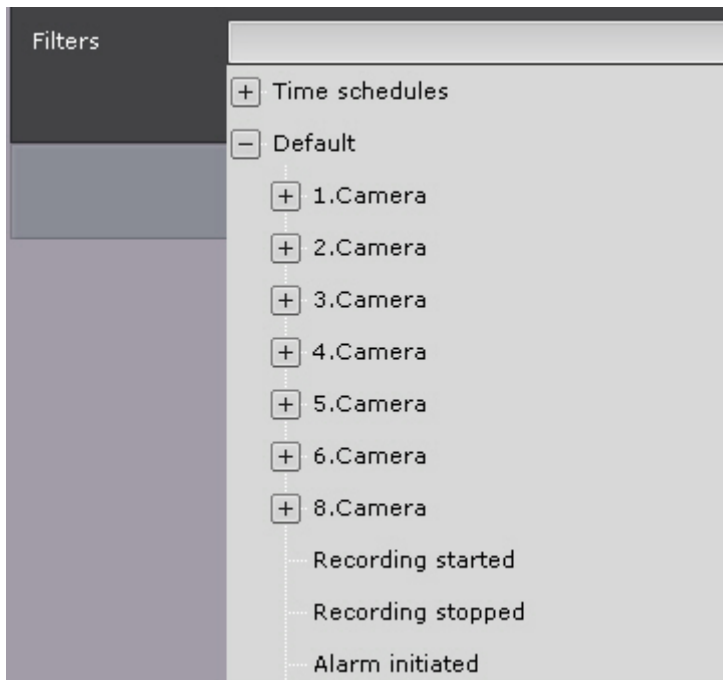

You can also filter events:



The following events are available for selection:

Object	Event	Image
<p>Axxon domain</p>	<p>A string of events. If you select an event from an Axxon domain, the macro will be launched when this event is received from any object in the Axxon domain.</p>	

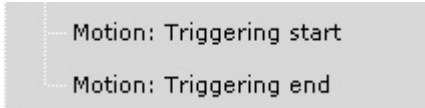
Object	Event	Image
Server	Server disconnected	
	Server connected	
Camera	Recording started	
	Recording stopped	
	Camera armed	
	Camera armed (restricted)	
	Camera disarmed	
	Alarm initiated	
	Alarm being processed by user	
	Alarm skipped	
	Alarm processed	
	Alarm processed - Critical alarm	
	Alarm processed - Non-critical alarm	
	Alarm processed - False alarm	
	Connected	
	Disconnected	
Signal lost		
Signal restored		 <p data-bbox="826 1487 1501 1608">You can set a threshold for these type of events: the time in seconds (0 to 100) between switching from Signal Lost to Signal Restored state. For example, setting 10 seconds threshold for the Signal Lost condition means triggering the macro only if the time interval between the last Signal Restored event and the new Signal Lost event is no less than 10 seconds.</p>

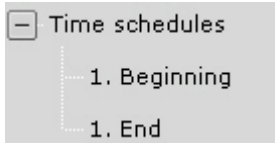
Object	Event	Image
<p>Group of cameras</p>	<p>A string of events.</p> <p>If you select an event from a group of cameras, the macro will be launched when this event is received from any camera in the group.</p>	 <p>A screenshot of a software interface showing a list of events for a group named 'Group 1'. The events listed are: Recording started, Recording stopped, Armed, Armed in private mode, Disarmed, Alarm initiated, Alarm being processed by user, and Alarm skipped.</p>
<p>Detector, Input and Output</p>	<p>Triggering start</p> <div style="border: 1px solid orange; padding: 5px; margin: 5px 0;"> <p>Attention!</p> <p>If triggering conditions for a macro include a Start Time of Detection Tool Trigger event, any changes in macro's settings that have been saved while the detection tool is triggered (before the End Time of Detection Tool Trigger event) will lead to re-executing the macro.</p> <p>The same logic is applied when you create a macro. If you are creating a macro, and the detection tool is triggered, the macro will be executed immediately after the creation is complete.</p> </div> <p>Triggering end</p> <p>Triggering (for detection tools, which do not have the start and end of the triggering, see Checking the Triggering of a Detection Tool)</p> <p>Specified Triggering (for face detection only, see Specific parameters for triggering a face recognition macro)</p>	 <p>A screenshot of a software interface showing two motion triggering events: 'Motion: Triggering start' and 'Motion: Triggering end'.</p>
<p>Archive</p>	<p>Archive partition error</p> <p>Archive partition restored</p>	 <p>A screenshot of a software interface showing two archive events: 'Archive partition error' and 'Archive partition restored', each with a sub-event 'Archive AliceBlue'.</p>
<p>Time Schedule</p>	<p>Beginning</p> <p>End</p>	 <p>A screenshot of a software interface showing two time schedule events: 'Time schedules' with sub-events '1. Beginning' and '1. End'.</p>

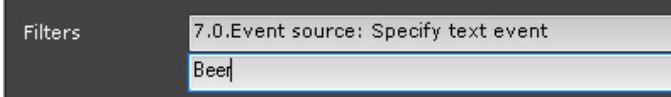
Object	Event	Image
Event source	<p>Description for the Event Source object, you must specify the trigger word or phrase. When it comes up in the captions, the macro starts.</p> <p>For example, this filter triggers the macro when the word "Beer" appears in the captions.</p> <p>If a macro is triggered by a simultaneous combination of words and/or values, use braces for logical AND. For example, {Beer} {Belgium}.</p>	

7.5.3.1 Specific parameters for triggering a face recognition macro

You can set a number of specific parameters which affect triggering a face recognition macro:

1. **Age** of the individual (requires activation of the **Gender and Age** parameter, see [Configure Facial Recognition](#)).
2. **Gender** of the individual (requires activation of the **Gender and Age** parameter, see [Configure Facial Recognition](#)). Value: **1** = female, **2** = male.
3. **TemperatureValue**: Body Temperature of the individual (requires the **Face Detection and Temperature Control**, see [Face Detection and Temperature Control with Mobotix M16 TR cameras](#)).

To set specific parameters, do the following:

1. Select **Face Appeared: Specified Triggering** event as a launch condition.

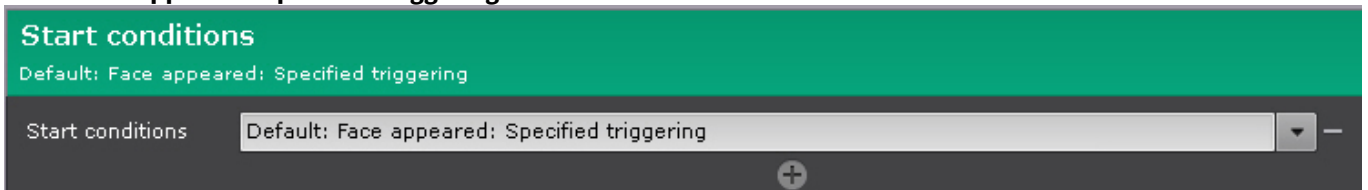

2. Click .
3. Specify a required parameter value in the corresponding field (**1**).

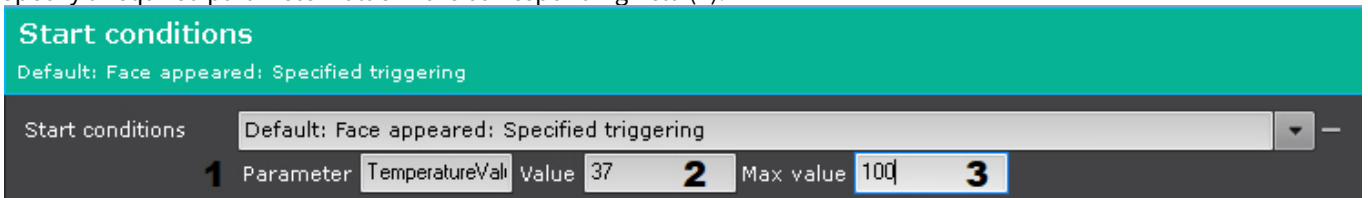

Attention!

The parameter is case-sensitive.

4. In the **Value** (**2**) and **Max value** (**3**) fields, set the range of parameter values within which the macro will be triggered.

Note

Examples.

If you set **Age** to [18, 100], the macro will be triggered only if the detection tool returns the age value of 18 or more.

If you set **Gender** to [1, 1], the macro will be triggered only if the detection tool returns the individual's gender as female.

If you set **Gender** to [2, 2], the macro will be triggered only if the detection tool returns the individual's gender as male.

If you set **TemperatureValue** to [37, 100], the macro will be triggered only if the detection tool returns the temperature value of 37 or more.

5. Add one or more actions into the macro (see [Settings specific to actions](#)).
6. Click the **Apply** button.

7.5.3.2 Triggering macros by statistical data

Event-triggered macros can be launched not only by events of particular type (see [Configuring Filters for Event-driven Macros](#)) but also by statistical parameters.

A macro can be initiated by the following parameters reaching pre-defined criteria:

1. The percentage of used space in Archive.
2. The percentage of used space on a volume.
3. The percentage of used RAM on a Server.
4. The percentage of used network bandwidth on a Server.
5. The percentage of CPU load on a Server.

To set up triggering macros by statistics, do as follows:

1. Select the desired parameter from the **Start Conditions** list in the **Statistics** group.

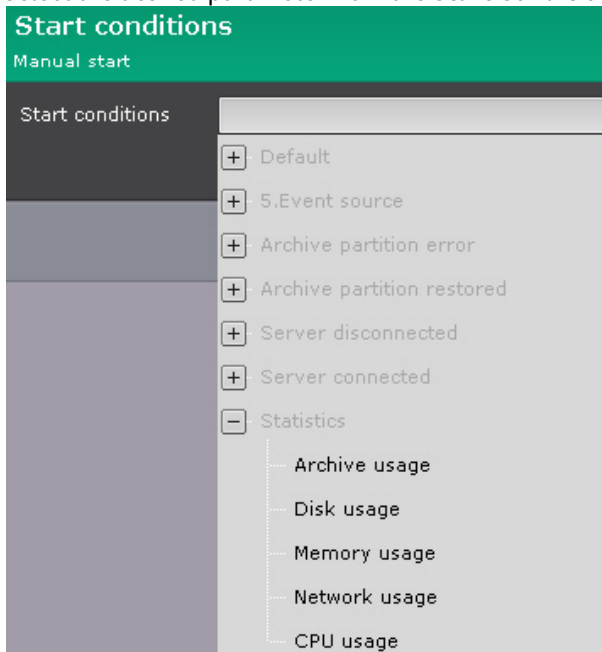

2. Enter the parameter definition into the **Item (1)** field.

Start conditions

Statistics: CPU usage

Start conditions: Statistics: CPU usage ▼

Item: Server1 **1** Value: 80 **2** Delta: **3** Trend: Rising **4** ▼

+ Add event filter

Archive usage	Archive in the following format:hosts/SERVER1/MultimediaStorage.AliceBlue/MultimediaStorage,
Disk usage	SERVER1@C:\ where SERVER1 is the name of a server within the Axxon domain, C:\ is the volume name. Important! You cannot monitor storage capacity of a disk fully allocated for Archive.
Memory usage (RAM)	The name of a server within the Axxon domain.
Network usage	The name of a server within the Axxon domain.
CPU usage	The name of a server within the Axxon domain.

3. Enter the threshold value into the **Value (2)** field.
4. For **Leaving** condition, enter the range into the **Delta (3)** field (see section 5).Enter the threshold value into the **Value (2)** field.
5. From the **Trend (4)** list, select a triggering condition for the macro.

Leaving	The macro is triggered if a parameter value goes out of the specified range [Value - Delta; Value].
Rising	The macro is triggered if the parameter value exceeds the threshold specified in the Value field.
Falling	The macro is triggered if the parameter value falls behind the threshold specified in the Value field.

Attention!

The triggering conditions are set not for current but for future events. For instance, if the current CPU load is 85%, and you set the triggering condition to exceeding 80%, the macro will be launched only when the CPU load exceeds 80% value next time.

6. If necessary, you can set several event and/or statistical conditions for triggering macros.

7.5.4 Settings specific to actions

7.5.4.1 Wait for event

This is the IF condition for running a command (only after the specified events occur).

You can enter the following parameters in the **Awaiting** command:

1. The time-out format is HH:MM:SS.

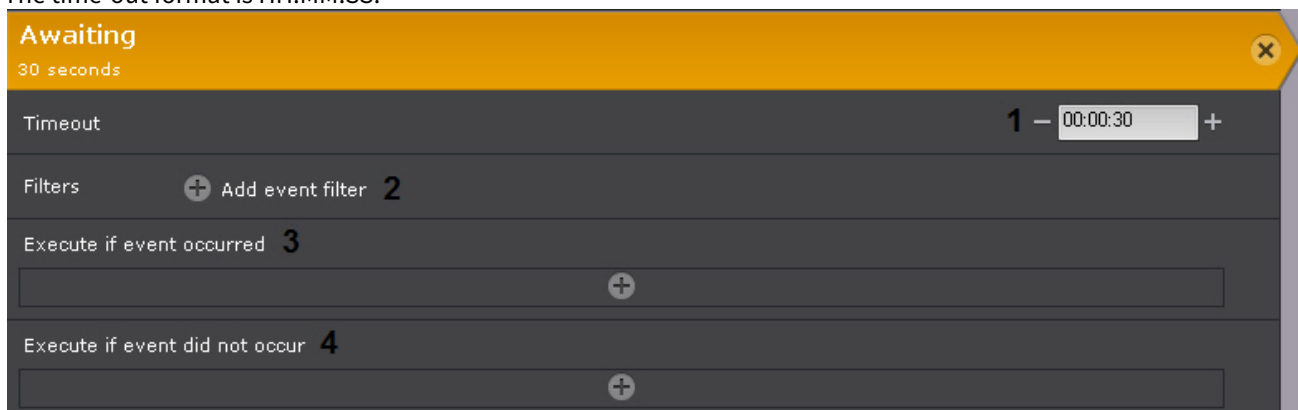

2. Break command - here you enter one or more events that override the Wait command. If you do not specify events, the time-out applies.
3. If necessary, select and configure the action to perform when an event from Break Command occurs. A new **Awaiting** instance is also an option.
4. If necessary, select and configure the action to perform if none of the events that were set in Break Command occurred during time-out. A new **Awaiting** instance is also an option.

For example, this macro is conditioned by the **Motion detected event** on **Camera 1 (1)**.

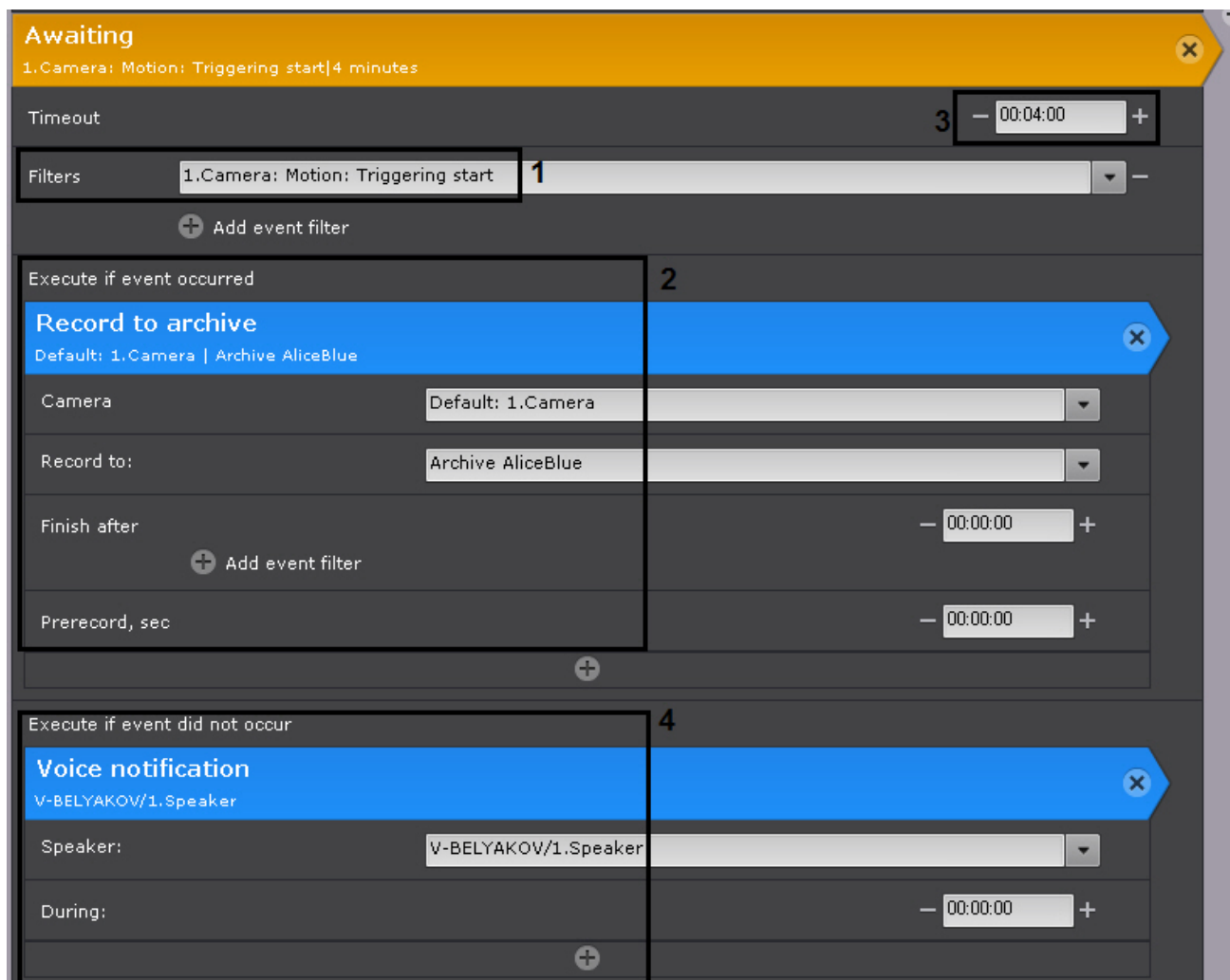

When it occurs, the macro continues. This also starts recording (2). Further macro actions are executed, if any. If this event does not occur, the time-out is 4 minutes (3). After this time, a sound notification (4) plays.

Attention!

The **Awaiting** command does not affect the commands below (outside of) it.

7.5.4.2 Wait for timeout

This command delays launch for downstream commands.

The time-out format is HH:MM:SS.



For example, when performing that macro, an alarm will be initiated in the system (1), and then after 10 seconds (2) - an audio alert (3).



7.5.4.3 Wait till previous action finishes

This is the IF condition for running a command (only if the previous steps are completed / not completed in the specified time).

To configure, set up the following parameters:

1. Set waiting period in HH:MM:SS format for previous action to be performed (1). If 00:00:00 is set, then waiting will last forever.

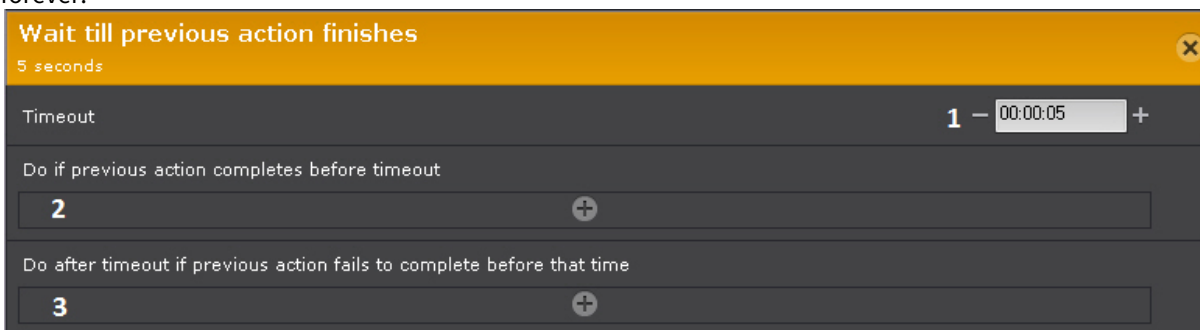

2. Specify the action to perform if the previous command was completed within the specified timeout **(2)**.
3. Specify the action to perform if the previous action was **not** completed within the specified timeout **(3)**. If the timeout is **00:00:00**, this setting is not applicable.

Attention!

This command does not affect the commands below (outside of) it.

Example: In this macro, replication **(1)** and the program on the client **(5)** start at the same time. If replication is completed within 10 minutes **(2)**, an Email message **(3)** is sent. Otherwise, a voice alert **(4)** is played.

Camera: Start replication 1

1.Camera | Archive AntiqueWhite | During: 00:00:00

Camera: 1.Camera

Archive: Archive AntiqueWhite

Whole period
 Time schedule
 During: 00:00:00
 Finish after

+ Add event filter

Wait till previous action finishes 5 seconds

Timeout: 2 - 00:10:00

Do if previous action completes before timeout

Send E-mail 3

Email message: V-BELYAKOV/1.User e-mail

To: mail@server.com

Subject: Notification: Attention, automatic rule is triggered.

Message: Replication complete

Do after timeout if previous action fails to complete before that time

Voice notification 4
V-BELYAKOV/6.Speaker

Speaker: V-BELYAKOV/6.Speaker

Finish after: 00:00:05

+ Add event filter

Launch external program on client 5

Path to file: "C:\Windows\System32\cmd.exe"

7.5.4.4 Record to archive

To configure **Record to archive**:

1. Selecting a camera or group of cameras for recording (1). An implicit selection of a video camera is also allowed - **Camera that initiated command execution**.

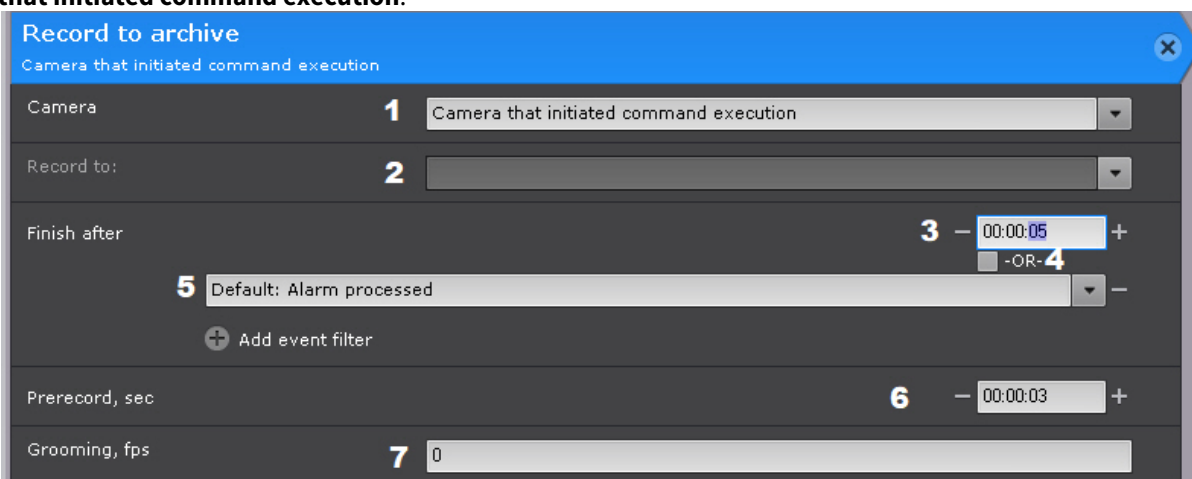

Attention!

If the start of the macro was triggered by the activation of input or output (see [Configuring filters for event-driven macros](#)) that is not connected to any camera, you need to select a specific camera here. If you select a group of cameras or a camera that triggered the command, the action will not start.

2. Select an archive to write to (2).
3. Configuring conditions that end recording.

Condition	Description
Timer (3)	Only a timer value is set. Recording stops according to the time setting.
Events Filter (5)	One or several events are set, the timer is set to 00:00:00. Recording stops on any IF event.
Timer (3) + Intelligent event filter (IF) (5).	One or several events are set, the timer is set to non-zero. Recording stops when the set time interval expires after any IF event (trigger) occurs.
Timer (3) + OR flag (4) + IF (5).	One or several events are set, the timer is set to non-zero, the OR flag is set. In this case, the recording stops on any of the two conditions: after the time interval expires or if an IF event (trigger) occurs.

Note

The OR flag can be set only if the timer setting is not 00:00:00.

Note

An implicit selection of an event is allowed - **Last event for condition that initiated execution**.

For example, if the event that triggered the execution of the command was the **Start time of detection tool trigger** from any type of detection tools, then the end event will be the **End time of detection tool trigger** from the same tool.

4. Set the pre-alarm recording time (6). The maximum pre-alarm recording time is 30 seconds.

Attention!

By default, the pre-alarm recording time interval is set to the value specified in Archive settings (see [Binding a camera to an archive](#)).

The longest pre-alarm recording time available in the Archive settings is used.

Changing this value in a specific macro does not affect the Archive settings.

5. If you have cameras in continuous recording mode (see [Binding a camera to an archive](#)) and you want to record with specified fps (see example 2) change the frame rate, enter the required frame rate (**7**). After the macro command completes, recording resumes at the frame rate specified in the archive settings.

You can use special codes:

0 - do not change the current frame rate (default);

-1 - record only I-frames;

1000 - record at the standard fps of the camera.

Attention!

FPS for pre-recording will not change.

If the macro command is set to complete some time after a specified event has been received (see p. 3), the frame rate will change for this Check-in Event-time.

Attention!

When you prune by frame dropping, in all video streams except MJPEG, only I-frames (Intra-Coded Frame or Key Frames) are saved, so please use codes: **-1** and **1000**.

If you go for a custom frame rate this will lead to dropping some key frames.

MJPEG video contains only I frames (Intra-coded pictures with a complete image), so it makes sense to set a desired frame rate here.

Example 1. A macro-command to initiate VMD-triggered recording to the Archive from any camera within **Default** Axon domain.

The screenshot displays a configuration window for a macro command. It is divided into two main sections: 'Start conditions' (green header) and 'Record to archive' (blue header).

Start conditions: The default is 'Motion detection: Triggering start'. A dropdown menu shows this selected. Below it is an 'Add event filter' button.

Record to archive: The camera is set to 'Camera that initiated command execution'. Below this is a 'Record to:' dropdown menu. The 'Finish after' field is set to '00:00:00'. There is an '-OR-' radio button option. Below that, the condition is set to 'Last event for condition that initiated execution'. Another 'Add event filter' button is present at the bottom.

Example 2. All video cameras from the **Default** Axon Domain are set to continuously record video at the specified fps by dropping frames (see [Binding a camera to an archive](#)). When you have a motion detection event, you need to switch to full fps recording. Configure the following macro to do so:

The image shows two configuration panels. The top panel, titled 'Start conditions', has a green header and contains a dropdown menu set to 'Default: Motion detected: Triggering start' and an 'Add event filter' button. The bottom panel, titled 'Record to archive', has a blue header and contains several settings: 'Camera' set to 'Camera that initiated command execution', 'Record to:' with an empty dropdown, 'Finish after' set to '00:00:00' with a '-OR-' option and a dropdown set to 'Last event for condition that initiated execution', 'Prerecord, sec' set to '00:00:03', and 'Gapping, fps' set to '1000'. Both panels have 'Add event filter' buttons.

7.5.4.5 Trigger an alarm

This starts recording and an alarm.

Most of the parameters are from the **Record to archive** command settings (see [Record to archive](#)). Other than that, there are following settings:

1. Select Alarm mode (**1**, always or only when there are no other active alarms for the camera).

The image shows the 'Alarm initiation' configuration panel with a blue header. It includes the following settings: 'Working mode' set to '1' and 'Initiate if no active'; 'Camera' set to '2' and 'Default'; '3' with a checked 'Random' checkbox; 'Record to:' set to '4' with an empty dropdown; and 'Alarm flag position' set to '5' and '00:00:00'.

2. Selecting a camera or group of cameras (**2**). An implicit selection of a video camera is also allowed - **Camera that initiated command execution**.

Attention!

If the start of the macro was triggered by the activation of input or output (see [Configuring filters for event-driven macros](#)) that is not connected to any camera, you need to select a specific camera here. If you select a group of cameras or a camera that triggered the command, the action will not start.

- If you selected a group of cameras or an Axxon domain at the previous step, you can select the **Random (3)** checkbox to initiate an alarm on a random camera from this group/domain.
- Select an archive to write to (4).
- In the **Alarm flag position** field, enter the number of seconds by which the alarm flag will be shifted back from the event time that started the macro (5).

Note

If the alarm flag position is set, the event footage plays from the moment corresponding to the flag's position, and not from the alarm start.

7.5.4.6 Switch output

This action switches a output to a pre-selected state.

To configure this action, do as follows:

- Select a output to switch by the macro (1). You can select any active output within your system, including outputs linked to another Server.

- Outputs switch back after On-time (2), or after Check-in Event-time (3) for any specified events.

7.5.4.7 Arm /disarm a camera

To configure these actions, select a camera or group of cameras that you want to arm or disarm. An implicit selection of a video camera is also allowed - **Camera that initiated command execution**.

Attention!

If the start of the macro was triggered by the activation of input or output (see [Configuring filters for event-driven macros](#)) that is not connected to any camera, you need to select a specific camera here. If you select a group of cameras or a camera that triggered the command, the action will not start.

7.5.4.8 Switch to a PTZ camera preset

To configure the action, set up the parameters:

1. **PTZ (1)** - select a PTZ unit. Any pan/tilt positioners / PTZ cameras can be used, including those from other Servers (if they are on).

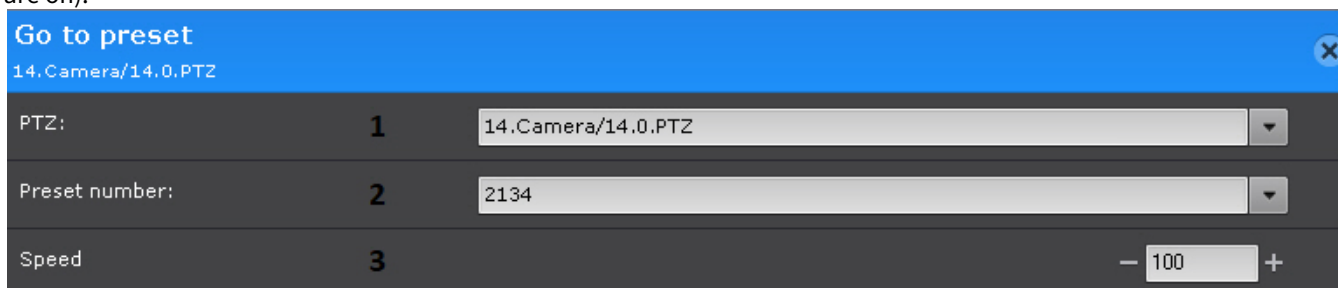

2. **Preset (2)** - select the camera preset to go to, when the macro starts.
3. **Speed (3)** - panning speed. This value should be in the range [1, 100].

7.5.4.9 Show camera

This opens the relevant layout and map with the camera marked on it.

To configure the command, do as follows:

1. Select a camera (1). An implicit selection of a video camera is also allowed - **Camera that initiated command execution.**

For the **Go to archive mode** (see step 2), you can select a group of cameras.

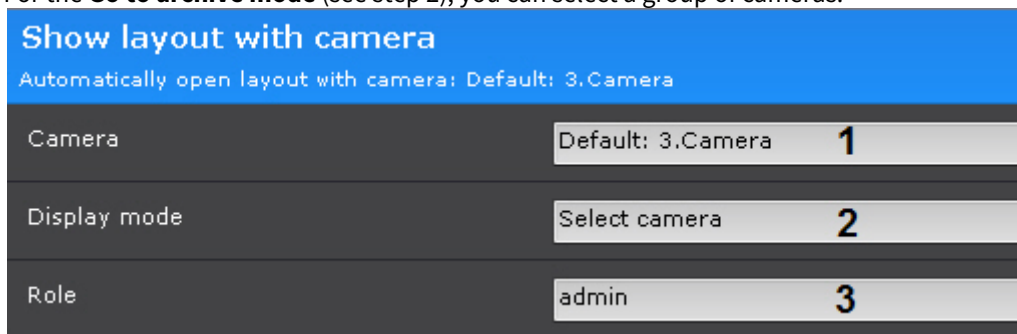

Note

In this software version, you cannot select a group of cameras for this action.

2. Select the display mode (2).

Display mode	Description
Select camera	The camera tile is highlighted on the layout
Zoom in camera	The camera tile is highlighted on the layout, the viewing tiles take up 98% of the screen
Zoom in and show map	The camera tile is highlighted on the layout, the viewing tiles take up 50% of the screen, the map under the tiles shows the camera.
Switch to immersion mode	Immersive mode , the viewing tiles take up 50% of the screen
Switch to Archive Mode	The camera window is highlighted on the layout and it is in archive mode. If a group of cameras is specified, then a layout is created with all the cameras in archive mode.

3. Select the user roles, this command applies to (3)

This command uses the following algorithm:

1. The system searches for layouts that contain the specified video camera and are accessible to the user.
2. The system chooses the layout with the minimum number of cells to display the selected video camera.

3. If the required layout does not yet exist, the system creates a new layout with a single video camera.
4. The system switches to the selected layout.
5. The specified process is running.

7.5.4.10 Opening layout

You can open any layout you created (the **Open layout**) or restore the previous one (the **Restore layout**).

To configure the **Open layout** command, do the following:

1. Select a layout (1).
2. Specify the ID of the monitor where you want to open this layout (2).
3. Select the user roles, this command applies to (3).

7.5.4.11 Starting export

This exports a snapshot or video.

To configure, set up the following parameters:

1. **Export agent (1)** - Select Server (aka **Export agent** object) to send recording to (see [Configuring an Export Agent](#)).

2. **Camera (2)** - select a camera for export. An implicit selection of a video camera is also allowed - **Camera that initiated command execution**.

Attention!

If the start of the macro was triggered by the activation of input or output (see [Configuring filters for event-driven macros](#)) that is not connected to any camera, you need to select a specific camera here. If you select a group of cameras or a camera that triggered the command, the action will not start.

3. **Archive (3)** - select an archive for export.
4. Sets the export interval (**4**).

Option	Description
Image export	Exports a snapshot with the time stamp identical to the start time of action. Important! The image cannot be exported if the video camera does not have an archive.
Time schedule	You need to select a time schedule. Exports images from within time schedule. Video recording interval - [Beginning of the specified time slot; the end of the specified time slot]
During	You should set the export duration in HH: MM: SS. The starting point of the exported video is the command start. End point is defined on the basis of the specified duration - (Interval [command start; command start + duration]).
Finish after	Select one or more events that will trigger export stop. The starting point of the exported video will be the command start, the end point - the moment of receiving any these events.

5. You can click the  button to add additional parameters:
 - a. File name (**6**).

Attention!

You can use the following templates for file names and text comments:

- **%startTime%** , or **[START_TIME]**, or **{startTime}**: the starting time of exported interval.
- **%finishTime%** , or **[FINISH_TIME]**, or **{finishTime}** : the finishing time of exported interval.
You may use the following templates for macros triggered by a text message from an event source (see [Configuring filters for event-driven macros](#)):
- **%startEvent%**, or **[START_EVENT]**, or **{startEvent}**: an event that triggered exporting.
- **%finishEvent%** , or **[FINISH_EVENT]**, or **{finishEvent}**: an event that stopped the export.

- b. Comments superimposed as captions over the exported video (**7**).
- c. **Offset (8)** is a time period used to roll back the start time of exported video. If you set this this parameter to non-zero, the time interval of the exported video will be as follows:
[action start - (duration + offset); action start - offset].
If exported video(s) fall into a specific slot on [Time Schedule](#), this parameter is used to define the start time for video retrieval. For example, if you set the Offset (GUI: Buffer) to 48 hours, all videos from the given Time Schedule slot recorded within 48 hours before the action start will be exported.

Example: A macro command for automatically exporting video recordings of all alarm events evaluated by operators as "confirmed".

Start conditions

Manual start

Start conditions -

+ Add event filter

Video export ✕

Camera that initiated command execution | During: 00:00:00

Export agent -

Camera -

Archive -

Image export

Time schedule

During: - +

Finish after

-

+ Add event filter

+

7.5.4.12 Start replication

This command starts the replication process.

To configure the command, perform the following:

1. Configure on-demand replication if replication is performed from the archive (see [Configuring data replication](#)). To replicate from the on-board storage (SD card or other storage embedded in the video camera), enable the corresponding object ([The Embedded Storage object](#)).
2. Select a video camera or a group of cameras to replicate (**1**). An implicit selection of a video camera is also allowed - **Camera that initiated command execution**.

Camera: Start replication ✕

Camera that initiated command execution | Offset 00:00:00 | During: 00:00:00

Camera **1** -

Archive **2** -

Whole period

Offline periods

Time schedule **3**

During: - +

Finish after

+ Add event filter

Offset **4** - + -

Attention!

If the start of the macro was triggered by the activation of input or output (see [Configuring filters for event-driven macros](#)) that is not connected to any camera, you need to select a specific camera here. If you select a group of cameras or a camera that triggered the command, the action will not start.

3. Select an archive file to which video recordings will be replicated (2).
4. Select the replication period (3).

Option	Description
Whole period	All missing video recordings made prior to the command start time will be copied.
Offline periods	The system copies footage recorded to embedded storage (camera's SD card) during offline periods (between consecutive Signal lost and Signal restored events). If no Offset parameter (see paragraph 5) is specified, the replication covers offline footage recorded during the last 24 hours.
Time schedule	Select a time schedule (see Creating schedules). All recordings made according to the time schedule settings for the last 24 hours prior to the command start time will be copied.
During	Set the replication duration in HH:MM:SS. Video recordings from the period [start action, start action + duration] will be copied. An additional Offset parameter can be specified as needed (see 5).
Finish after	Select one or more end events. All video recordings between the start point (when the action starts) and the end point (when the event is received) will be copied. Important! Replication will not start until the end event is received.

5. Specify **Offset(4)**, if you specified **Duration** for replication. Video recordings from the period [start action - offset, start action + duration - offset] will be copied.

To run replication on schedule (corresponding to **Time schedule 1**), configure the macro as follows:

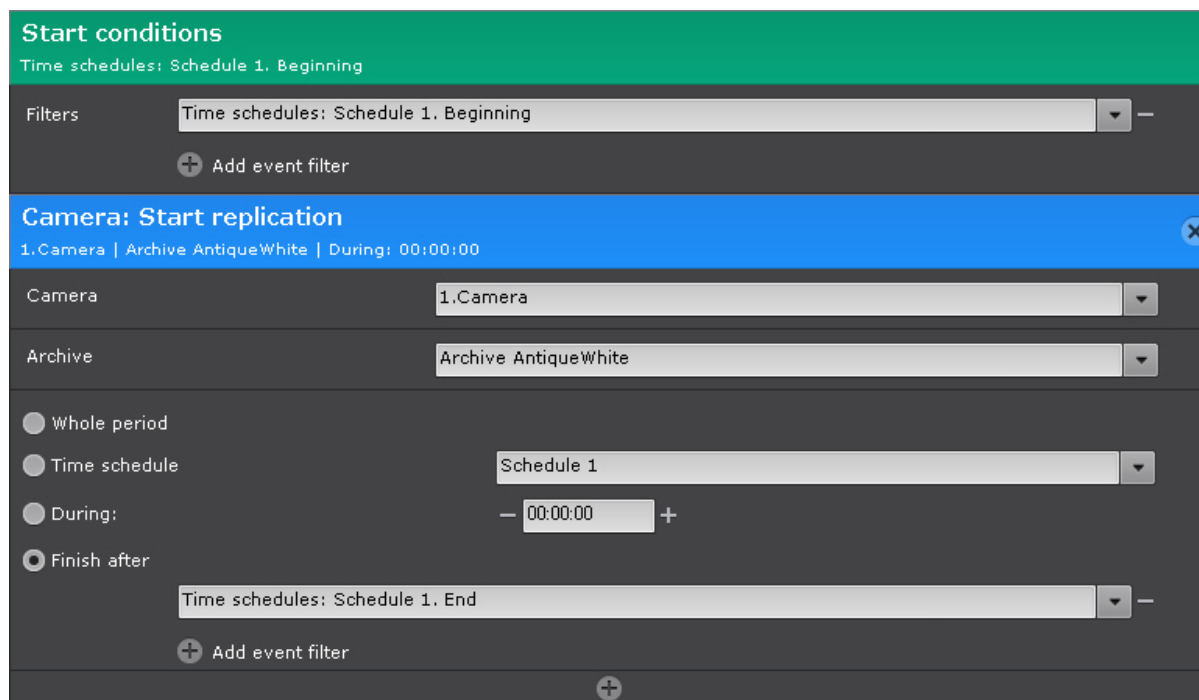

7.5.4.13 Play audio on Server

You can play back audio through a Server PC's loudspeaker.

Attention!

To make the client-side audio playback possible, you have to create a **Speaker** object allowing **Play on Server** playback mode (see [The Speaker Object](#)).

To configure the action, set up the parameters:

1. Select a speaker (1).

2. In the **Audio file** field (2), enter the full path to the audio notification file.
3. Configure a condition (IF event, trigger) that will cancel the notification:

Condition	Description
Timer (3)	Only a timer value is set. Alerts are cancelled according to the time setting.
Events Filter (5)	One or several events are set, the timer is set to 00:00:00. Alerts are cancelled according to the IF event (trigger).
Timer (3) + Intelligent event filter (IF) (5).	One or several events are set, the timer is set to non-zero. Alerts are cancelled in a given time after the selected IF event (trigger) occurs.
Timer (3) + OR flag (4) + IF (5).	One or several events are set, the timer is set to non-zero, the OR flag is set. In this case, the alert is cancelled on any of the two conditions: after the time interval expires or if an IF event (trigger) occurs.

Note

The **OR** flag can be set only if the timer setting is not 00:00:00.

Note

An implicit selection of an event is allowed - **Last event for condition that initiated execution.**

For example, if the event that triggered the execution of the command was the **Start time of detection tool trigger** from any type of detection tools, then the end event will be the **End time of detection tool trigger** from the same tool.

7.5.4.14 E-mail notification

This sends emails to the pre-set addresses. Exported videos or snapshots can be attached.

Attention!

Connection to AxxonNet is required to receive alerts by email (see [AxxonNet Setup and Operation](#)).

To configure e-mail notification:

1. **E-mail (1)** - select the system object for email notifications when a macro starts.

2. Enter e-mail addresses of anyone who should be notified (2).

Note

Multiple email addresses can be specified. Separate them with comma (,) or semicolon (;).

Note

Notifications will be sent at the address you specified when configuring the **E-mail Message** object (see [The E-mail Object](#)).

3. **E-mail subject (3)** - select the the subject field for email notification .
4. **E-mail text (4)** - enter the text for email notification.

Note

You can use templates to build a message body (see [Text templates in macros](#)).

5. If necessary, you can attach exported videos or snapshots to your message. Click  to add and configure additional parameters. Configuration of these parameters is identical to configuration of export (see [Starting export](#)).

Note

If the **Period** is not specified, the snapshot is sent. You can set the format of video / snapshot export in the Export agent settings (see [Configuring an Export Agent](#)).

6. If a macro is launched from a group of cameras (see [Configuring filters for event-driven macros](#)), you can send frames from all cameras as attachment in a single email message. To make it possible, select the **All in one Email** checkbox (6). If this checkbox is not selected, camera images will be sent in separate letters.

7.5.4.14.1 The E-mail Object

The **E-mail** object is used to configure electronic messages which can then be sent to a user as an automatic response when a detection tool is triggered.

7.5.4.14.1.1 Creating the E-mail Object

To create an **E-mail** object, you must perform the following steps:

1. In the list of devices, highlight a **Server** object and click the **Create Email notifier** button.

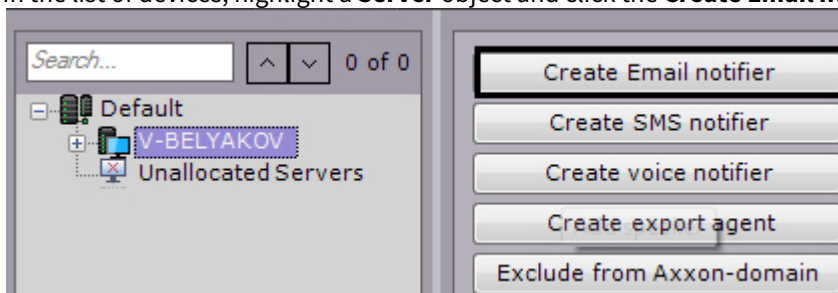

2. Click the **Apply** button.
3. When you do this, an **E-mail** object appears in the list of devices.

Creation of the **E-mail** object is now complete.

7.5.4.14.1.2 Configuring the E-mail Object

To configure an **E-mail** object, you must perform the following steps:

1. In the list of devices, highlight the **E-mail** object which needs to be configured (1).

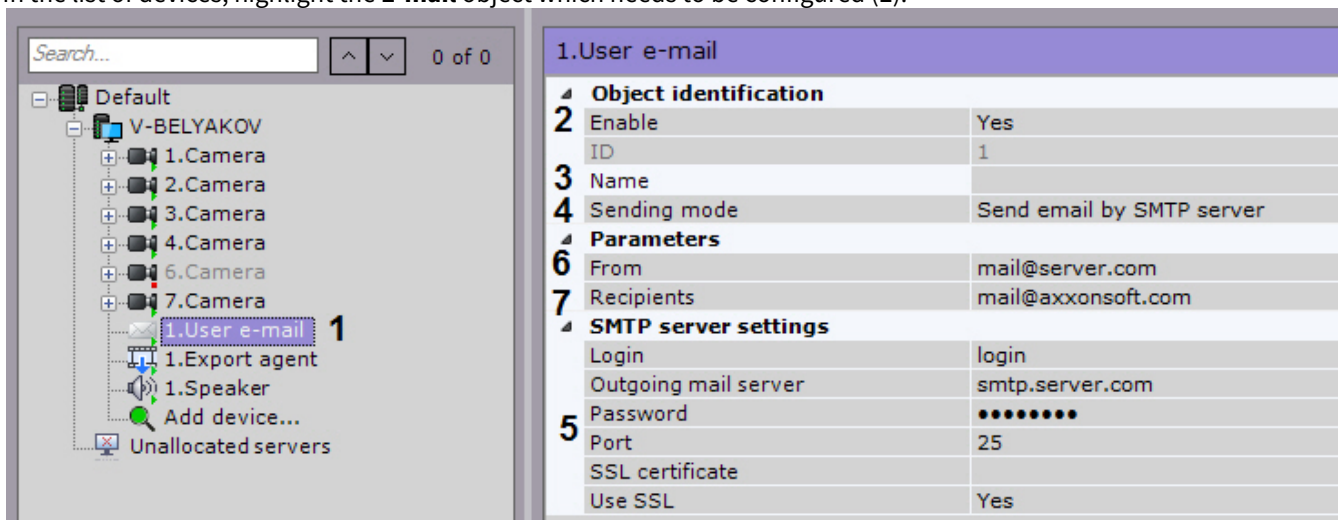

2. Activate the **E-mail** object (2) by selecting **Yes** in the **Enable** list.
3. In the **Name** field (3) enter the desired name of the **E-mail** object.
4. Select the mode for sending e-mail alerts: through AxxonNet or through the specified SMTP server (4).

Attention!

To send alerts via AxxonNet, you should connect to it (see [AxxonNet Setup and Operation](#)).

AxxonNet has a limit of 10 messages a day.

Note

Message via AxxonNet will be sent within one minute.

5. Configure the SMTP server, if this mode has been selected (5):
 - a. In the **SSL certificate** field, specify the path to the SSL certificate file, if you use this protocol.
 - b. If you need to use an SSL-encrypted connection when connecting to the outgoing mail server, select **Yes** from the **Use SSL** list.
 - c. In the **Name** field, enter the name of the user account used to send messages on the outgoing mail server.
 - d. In the **Password** field, enter the password for the user account on the outgoing mail server.
 - e. In the **Port** field, enter the number of the port used by the outgoing mail server.
 - f. In the **Outgoing mail server** field, enter the name of the outgoing SMTP mail server.
 - g. In the **From** field, enter the e-mail address from which the messages will be sent (6).

Attention!

When using e-mail notification, mail servers may lock the user account, or deny authentication in some cases. We recommend you to set all security parameters to off in your e-mail account.

6. Enter e-mail addresses of anyone who should be notified (7).

Note

Several email addresses can be specified. Separate them with semicolon (;)

7. Click the **Apply** button.

Configuration of the **E-mail** object is now complete.

7.5.4.14.1.3 Checking E-mail Notification

To check e-mail notification from an **E-mail** object, send a test message by clicking the **Test** button.

1.User e-mail

Object identification	
Enable	Yes
ID	1
Name	
Parameters	
Recipients	mail@server.com

Name
Email notifications object name.

Test

When you do this, the following message is sent to the e-mail address indicated in the **Recipients** field (see the section [Configuring the E-mail Object](#)): "Test message"

Note

If the recipient does not receive the message, make sure that the settings of the **E-mail** object have been properly configured

7.5.4.15 SMS notification

To configure the action, set up the parameters:

1. **Modem (1)** - select the **SMS** object for SMS notifications when a macro starts.

Send SMS

Modem:	1	<input type="text"/>
Message text:	2	<input type="text"/>
Phone number:	3	<input type="text"/>

2. **Message text (2)** - enter the SMS text for SMS notifications.

Attention!

The number of characters in a message is limited to:

- 160 ASCII characters;
- 70 Unicode characters.

If the limit is exceeded, a multi-part text message is transmitted.

Note

You can use templates to build a message body (see [Text templates in macros](#)).

3. Enter the phone numbers of anyone who should be notified (3).

Note

Several phone numbers can be specified. Separate them with semicolon (;).

Note

Notifications / alerts will also be sent at the phone numbers you specified when configuring [The SMS Object](#)

7.5.4.15.1 The SMS Object

The **SMS** object is used to configure SMS messages which can then be sent to users as an automatic response when a detection tool is triggered.

Attention!

To use SMS notification, you need a modem recognizable by the OS as a COM device. No other types of modems can be used for this purpose.

For example, the following modem types are supported:

1. Siemens TC-35.
2. Flyer U12 (Windows 7 and higher).

Other modems may work or not. We recommend you to check supported Windows versions for each particular device. Carrier-locked modems are not recommended.

Note

If a USB modem is used to send SMS messages, use the modem utility from the modem software bundle. It will unlock the modem for correct operation

7.5.4.15.1.1 Procedure of configuring SMS notifications

To configure SMS notifications:

1. Stop the Server.
2. Connect a modem and, in the utility supplied with the modem, wait for the signal level to be determined.

3. Make sure that the number of the SMS center is shown. Do not connect to the Internet.
4. Start the Server and Client. Create and configure an **SMS** object.

7.5.4.15.1.2 Creating the SMS Object

To create an **SMS** object, you must perform the following steps:

1. In the list of devices, highlight a **Server** object and click the **Create SMS notifier** button.

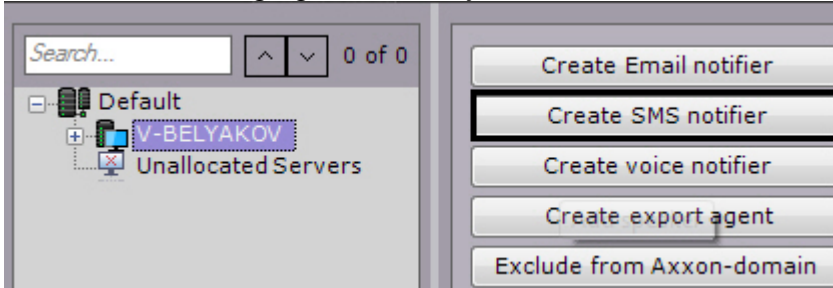

2. Click the **Apply** button.
3. When you do this, the **SMS** object appears in the list of devices.

Creation of the **SMS** object is now complete.

7.5.4.15.1.3 Configuring the SMS Object

To configure an **SMS** object, you must perform the following steps:

1. In the list of devices, highlight the **SMS** object which needs to be configured (1).

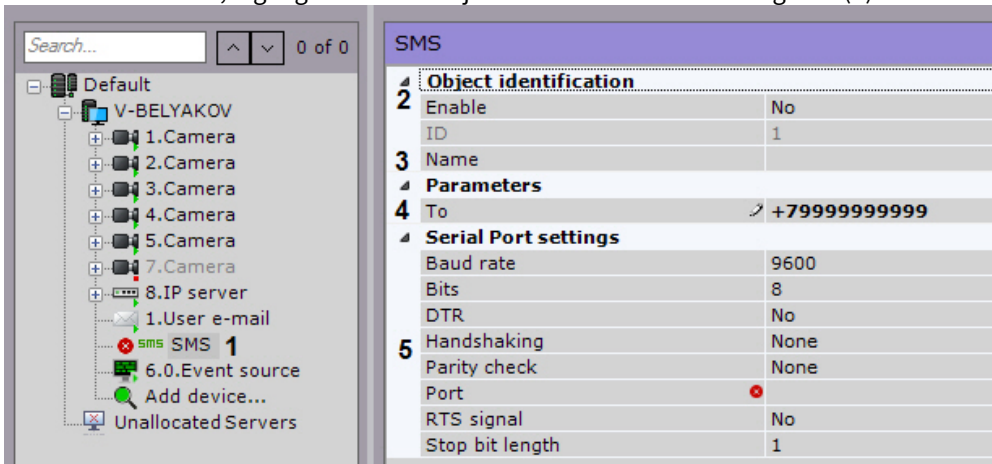

2. Activate the **SMS** object (2) by selecting **Yes** in the **Enable** list.
3. In the **Name** field (3) enter the desired name of the **SMS** object.
4. In the **To** field (4), enter the cellular telephone number, in international format (*+<country code>xxxxxxxxx*), to which messages will be sent.
5. In the **SerialPort settings** group (5), indicate the port settings used to connect to the GSM modem by which SMS messages will be sent:
 - a. If you need to use a DTR control signal, select **Yes** from the **DTR** list.
 - b. In the **Bits** field, enter the number of bits in the byte of a data packet.
 - c. In the **Stop bits length** field, enter the number of bits in the stop bit of a data packet.
 - d. If you need to use a parity check when transmitting data, select the desired method of parity check from the Parity list.
 - e. From the **Port** list, select the serial port used to connect to the GSM modem.
 - f. If hardware control of the serial port data protocol is enabled (see step 5.8) and you need to use an RTS signal, select **Yes** from the **RTS signal** list.
 - g. Select the speed for data transmission via the GSM modem from the **Baud rate** list.
 - h. If you need to control the serial port data protocol, select the desired method of control from the **Handshaking** list: hardware (RTS/STS), software (XOn/XOff), or alternating.
6. Click the **Apply** button.

Configuration of the **SMS** object is now complete.

7.5.4.15.1.4 Checking SMS notifications

To check SMS notifications from an SMS message object, send a test message by clicking the **Test message** button.

When you do this, the following message is sent to the mobile number indicated in the **To** field: "This is a test message to check Axxon Next SMS notification."

Note

If the recipient does not receive the message, make sure that the settings of the SMS object have been properly configured

7.5.4.16 Starting an external program on Clients

This starts an external program on your Axxon Next client.

The external program is started on all Clients that are connected to the domain.

Attention!

The external program is not started on a computer that is an Axxon Next Server, if the Client is not running on the computer when a macro is triggered.

To configure, do the following:

1. On all Clients, enter the path to the program's executable / run file (1). You can specify a network path. You can also add command-line options.

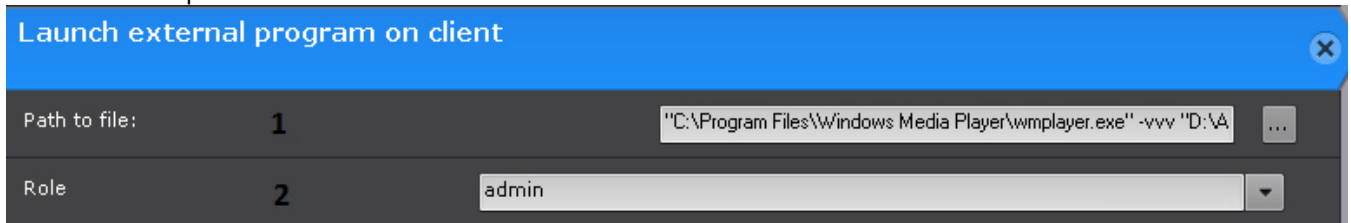

2. Select users of the (external) program (2).

Attention!

To run the program, you need administrator permissions. You have to disable UAC (in OS *Windows Server* 2012 versions, 8, 8.1 and you need to edit [the registry](#)), or start *Axxon Next* with administrator rights

7.5.4.17 Starting an external program on Servers

This starts an external program on your Axxon domain.

Attention!

Any software containing a GUI is not recommended to be executed on the Server. If you encounter a problem launching interactive services, please refer to the [Windows OS user manual](#).

To configure, do the following:

1. Allow interaction of the server **NGP Host service** with the desktop: Start > Control Panel > Administrative Tools > Services > Net Logon -> Properties - Log on.

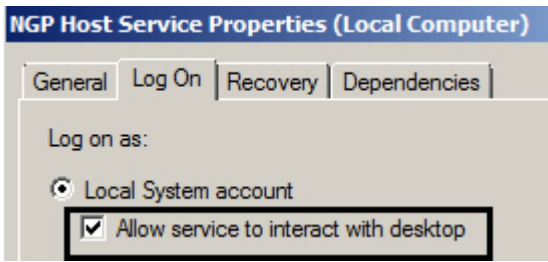
**Note**

For **Failover Server and Client** installation type (see [Installation](#)), you have to allow the **NGP RaFT supervisor service** to interact with desktop.

2. Add to folder <Directory where Axxon Next is installed>\UserScripts\ one or more .bat files with the application startup command.
The command should include a path to the executable file. You can specify a network path and command-line options (see [Starting an external program on Clients](#)).
3. Select the server where you want to run the program (1).

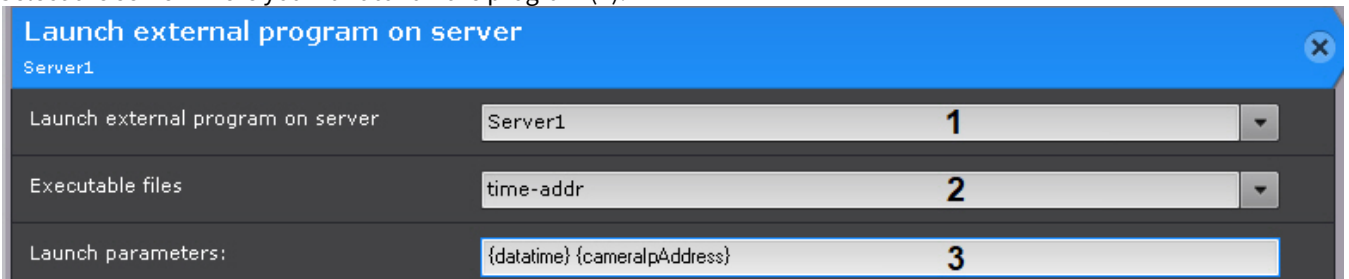

4. Select a bat. file with the run command (2).
5. Enter templates, if they were set via a bat file (3).

Example 1: If you apply the following bat file:

```
SET "datetime=%1"
SET "cameraIpAddress=%2"

msg * Current time is %datetime%, IP-address: %cameraIpAddress%
```

executing the macro will lead to the following message:

Current time is 20200204T132336.292986, IP-address: 10.0.11.209

OK

Example 2: Exporting camera connection status events (offline/online) to a csv.bat file containing the following:

```

SELECT "timestamp"
      ,REGEXP_REPLACE("object_id", 'hosts/', '') as device,
      CASE
        WHEN ("any_values"::json->>'state') = '4' THEN 'Signal Lost'
        WHEN ("any_values"::json->>'state') = '3' THEN 'Signal
Restored'
        ELSE ''
      END as state
FROM public."t_json_event"
WHERE type = '0' AND ("any_values"::json->>'state'='3' OR "any_values"::json->>'state'='4') AND
timestamp >= '20200211T0000'
ORDER by timestamp DESC

```

Example 3: Exporting detection tools triggering events to a csv.bat file containing the following:

```

SELECT "timestamp",
      REGEXP_REPLACE("object_id", 'hosts/', '') as device,
      CASE
        WHEN ("any_values"::json->>'phase') = '1' THEN 'Closed'
        WHEN ("any_values"::json->>'phase') = '2' THEN 'Opened'
        ELSE ''
      END as state
FROM public."t_json_event"
WHERE type = '1' AND timestamp >= '20200209T110000' AND "object_id" LIKE '%ray%'
ORDER by timestamp DESC

```

7.5.4.18 Start / stop slideshows of layouts.

These actions start and stop the slideshow of the layouts on the operator's monitor (see [Selection and Slideshow of Layouts](#)).

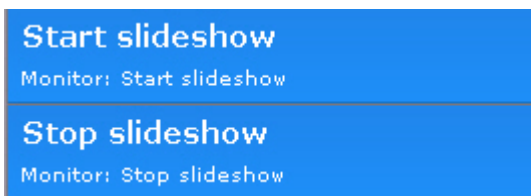

Note

To stop slideshow of layouts, you can select any camera window with the left click. After restarting the client, slideshow resumes.

7.5.4.19 Enable/disable a component

This action enables or disables the selected camera, detection tool or input.

To configure this action, do as follows:

1. Select the required object (**1**).

Enable or disable component		
1.7.6 Camera		
Component	1	1.7.6 Camera
Enable or disable	2	Disable

2. Select the desired command (2).

7.5.4.20 Checking for archive video recordings

This action checks recorded video from a specific camera or group of cameras for the specified period.

To configure this action, do as follows:

1. Select a camera or a group of cameras to verify their video footage (1).

Check archive record
✕

15.Camera 1 | Archive AliceBlue | 1 minute

Camera	1	15.Camera 1	▼
Record to:	2	Archive AliceBlue	▼
Depth of check	3	– 00:01:00	+
Execute if event occurred	4	+	
Execute if event did not occur	5	+	

Send E-mail
✕
+

Email message:	▼
To:	_____
Subject:	Notification: Attention, automatic rule is triggered.
Message:	_____

+
+

Attention!

If the start of the macro was triggered by the activation of input or output (see [Configuring filters for event-driven macros](#)) that is not connected to any camera, you need to select a specific camera here. If you select a group of cameras or a camera that triggered the command, the action will not start.

2. Select an archive where you want to check if recorded video is available (2). If you leave the field empty, all recorded video in the camera's archives is checked.
3. Specify how far back in the past to scan (3). The verification time period covers: [the time of the action start - (minus) the depth of the check; start time of the action].
4. Select a reaction if the archive entries are found (4).
5. Select a reaction if the archive entries are not found (5).

Note

If [E-mail](#) - or [SMS-notification](#) is selected as a reaction, then the target cameras will be indicated in the message (if a group of cameras was selected) for which there are no entries in the archive for the specified period.

You can also use two special purpose templates in the message:

{failureRecordCheck} – failed verification of a record in a Archive (format: Server Name|Camera Name|Archive Name).

{successRecordCheck} – successful verification of a record in a Archive (format: Server Name|Camera Name|Archive Name).

Important! For proper execution of the macro, synchronize the time across all Servers within the Axxon domain.

7.5.4.21 Switching to Forensic Search results

This allows you to open saved search results.

To configure this action, do as follows:

1. Select a camera (**1**).

The screenshot shows the MomentQuest2 configuration window. At the top, it says 'Automatically open layout with camera: 1.Camera 1'. Below this is a table with three rows: 'Camera' with value '1' and '1.Camera 1', 'Query' with value '2' and '1', and 'Role' with value '3' and 'admin'.

Parameter	Value	Selected Value
Camera	1	1.Camera 1
Query	2	1
Role	3	admin

2. Select a previously saved search query (**2**).
3. You can target users by selecting a role (**3**).

7.5.4.22 Voice notification from Client

Use this action for routing the voice transmission from a client PC to a designated loudspeaker.

Attention!

If a Client resides behind the NAT, you have to specify the external IP address of the switch for this Client with a port range larger than 1000 (see [Network settings utility](#)).

To configure this action, do as follows:

1. Select a speaker (1).

2. Select a microphone (2).
3. Specify sensitivity from 0 to 100 (3).

To stop sound, use the **Stop voice notification from client** command on Client.

To configure this command, select a speaker (4) and a microphone (5).

7.5.4.23 Voice notification on Client

You can play back audio via client PC's loudspeakers.

Attention!

To make the client-side audio playback possible, you have to create a **Speaker** object allowing **Play on Clients** playback mode (see [The Speaker Object](#)).

To configure this action, do as follows:

1. Select the speaker for audio alerts (1) playback.

2. Select a role to address alerts to specific users (2).
3. If you need to cancel audio alerts after some time, set the required time interval (3).
4. For event-triggered audio alerts cancellation, do the following:
 - a. Create a new event macro with all required events filtered (see [Create Macros, Configuring filters for event-driven macros](#)).
 - b. Add a **Stop voice notification on client** action to a macro.

- c. Select the loudspeaker where you want to cancel audio alerts **(1)**.
- d. If you need to cancel alerts after a certain amount of time, set the required time interval **(2)**.

7.5.4.24 Executing a macro

This action launches another macro.

To set up this procedure, select the necessary macro.

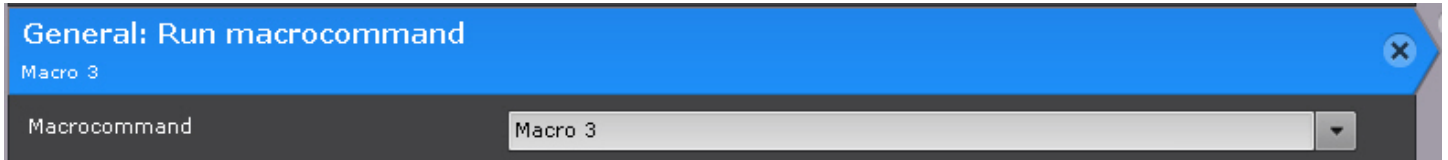

This action launches only event-related macros.

7.5.4.25 Alarm dispatch

This action consists of alarm management and evaluation.

To configure this action, do as follows:

1. Select a video camera or a group of cameras to dispatch an alarm **(1)**.

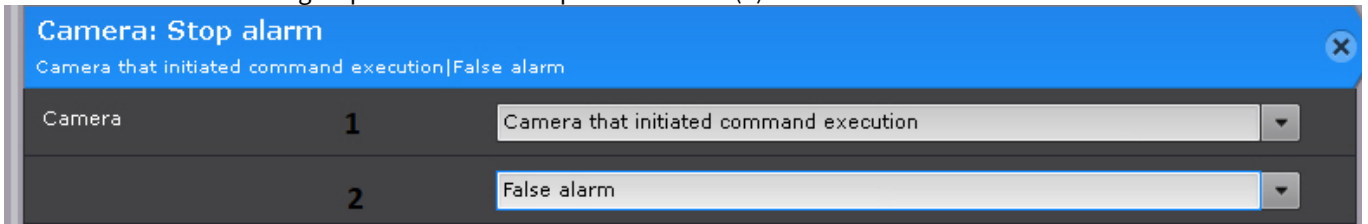

Attention!

If the start of the macro was triggered by the activation of input or output (see [Configuring filters for event-driven macros](#)) that is not connected to any camera, you need to select a specific camera here. If you select a group of cameras or a camera that triggered the command, the action will not start.

2. Select the alarm status **(2)**.

7.5.4.26 Executing a web query

This action sends a GET or POST query to a specified Server.

To configure this action, do as follows:

1. Select the authentication method: Basic or Digest **(1)**.

General: Execute web-query		
Basic		
Authentication method	1	Basic
Command	2	GET
HTTP/HTTPS	3	HTTP
IP address	4	10.0.11.55
Port	5	80
Username:	6	user
Password:	7	password
Path	8	/camera/list
Query	9	

2. Select query type (2). 4 types are available: POST, GET, PUT, DELETE.
3. Select HTTP or HTTPS Server protocol (3).
4. Enter the IP address of the Server (4).
5. Enter the port number of the Server (5).
6. Enter the user name (6) and password (7) to be used for automatic authorization.
7. Enter query string (8).
8. For a POST query, enter its body (9).

Note

You can use templates to build a query body (see [Text templates in macros](#)).

7.5.4.27 Text templates in macros

You can use message templates in commands (see [E-mail notification](#), [SMS notification](#), [Executing a web query](#)) that involve sending notifications:

- {cameraNode} - Server name;
- {eventNode} - Server name (used if the macro launching condition is not linked to a particular camera);
- {cameraName} - name and short name of the camera that initiated the macro;
- {cameraLabel} - just the camera's name;
- {cameraIpAddress} - camera's IP address;
- {cameraId} - camera's ID;
- {cameraRef}- the VIDEOSOURCEID identifier;
- {plate} - recognized vehicle number;
- {name} - name of the recognized person from Lists of Facial Templates;
- {age} - age of the recognized individual;
- {gender} - gender of the recognized individual;

Attention!

The {age} and {gender} templates can be applied when the following conditions are met:

- a. The **Gender and Age** parameter is activated in facial detection tool settings (see [Configure Facial Recognition](#)).
- b. The **Face Appeared: Specified Triggering** event is selected as a launch condition for this macro (s).

- {appearedTime} - UTC time of object detection;
- {dateTime} - date and UTC time of triggering the macro in ISO format;
- {serverDateTime} - local Server time of triggering the macro in ISO format;
- {rectangles} - coordinates and size of the object that triggered the detection tool;
- statistics templates:
 - {cpuUsage} - percentage of CPU load on a Server;
 - {netUsage} - percentage of used network bandwidth on a Server;
 - {memoryUsage} - percentage of used RAM on a Server;
 - {diskUsage} - percentage of disk usage;
 - {archiveUsage} - percentage of Video Footage usage.

Attention!

You can apply statistics templates only if you launch a macro by a corresponding statistical condition (see [Triggering macros by statistical data](#)).

Note

Templates allow {} and %%. For example, %cameraId%.

Note

Date/time templates (such as `dateTime`, `serverDateTime`, `appearedTime` and `serverAppearedTime`) offer an extended input option which allows you to set date and time in arbitrary format. A format description parameter must be contained within a pair of `@` symbols.

Here's an example: `{dateTime@%Y-%m-%d %H:%M:%S@}`. In this case, the actual format is presented as 2020-10-04 18:43:23.

Available parameters:

Parameter	Description
%a	Abbreviation for the day of the week
%A	Full name of the day of the week
%b	Abbreviation for the month
%B	Full name of the month
%y	Last two digits of the year
%Y	Full number of the year
%m	Month of the year
%d	Day of the month
%H	Hour in 24h format
%M	Minute as a decimal number
%S	Second as a decimal number
%F	Fractions of second

Combined parameters:

Parameter	Description
%D	Equivalent to %m/%d/%y
%T	Equivalent to %H:%M:%S

E.g. this macro sends an email of the following format when a water level detection tool triggers:

Start conditions

Default: 5.Camera: Water level detection: Triggering start

Start conditions: ▼ -

+ Add event filter

Send E-mail ✕

Email message: ▼

To:

Subject:

Message:

Server: {cameraNode}
 Camera: {cameraIpAddress} {cameraName}
 Time: {dateTime}

+

Subject: Notification: Attention, water level detection is triggered.

Server: Server1
 Camera: 10.0.11.36 34.Camera
 Time: 20190812T085517.926430

7.5.5 Cyclical macros

Attention!

If you do not have the **Wait** command in a cyclic macro, the time-out between cycles is 1 second.

Example 1. This macro runs continuously (1), starting from the moment that you saved it.

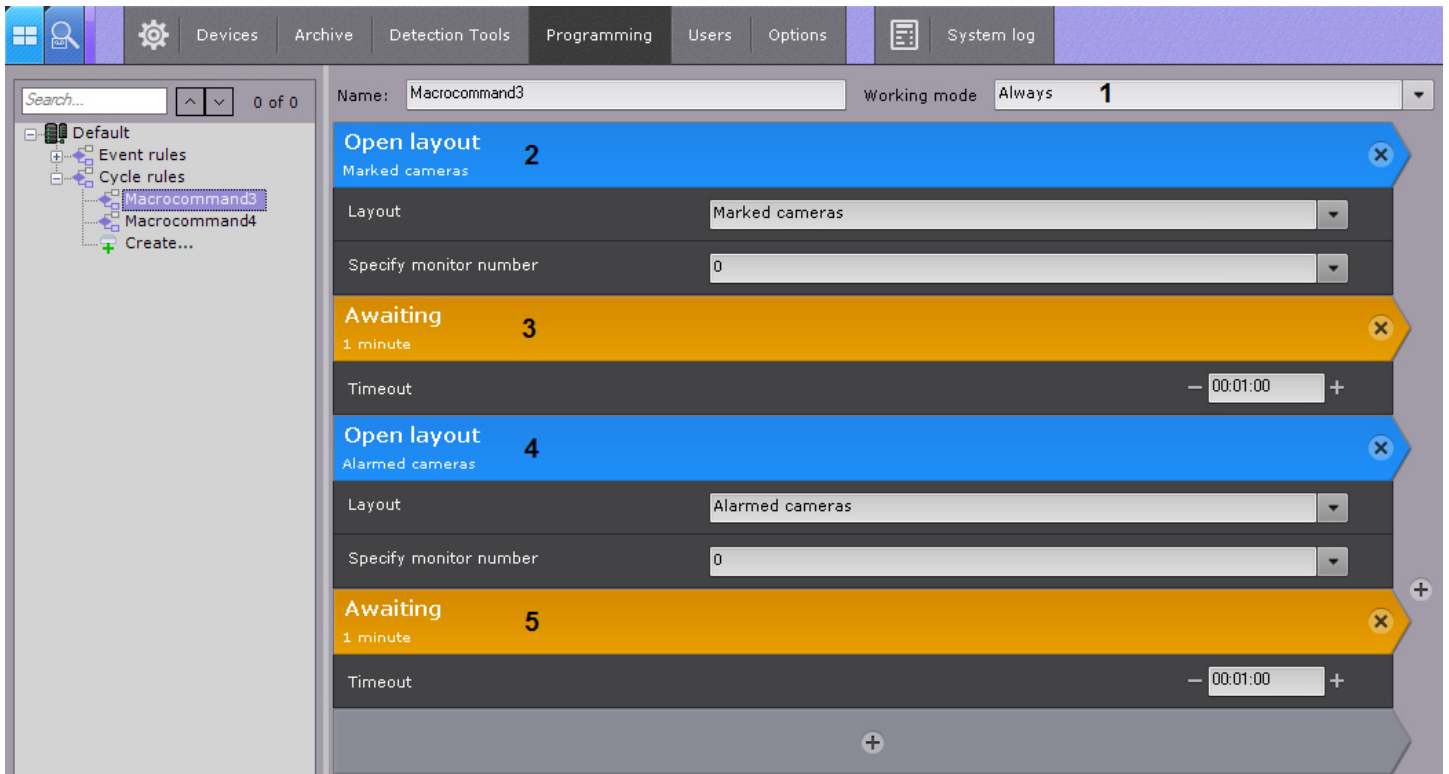

The cycle consists of alternating layouts with marked cameras (2) and layouts with alarmed cameras (4). Interval - 1 minute (3, 5).

Example 2. This macro runs continuously within the time schedule 1 (1).

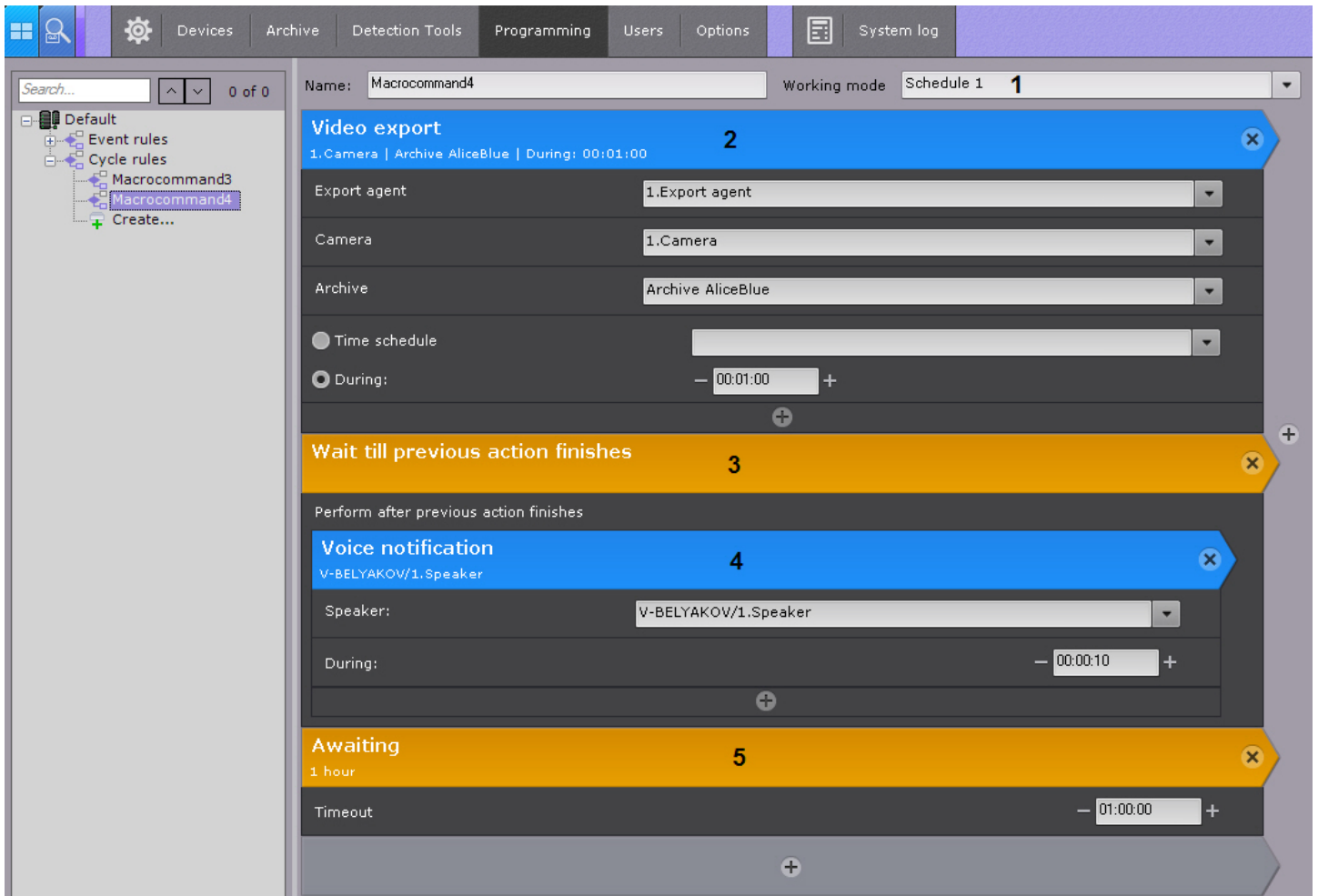

Every hour (5) video from camera 1 is exported (2). After the export is completed (3), an audio alert is sounded (4).

[Wait for timeout](#)

[Wait till previous action finishes](#)

7.6 Configuring user permissions

In Axxon Next, every user has permissions based on their role.

By default, there is one role (**admin**) and one user (**root**). The **root** user belongs to the **admin** role and has rights to configure all components of the video surveillance system. To add a user with individual permissions, create a new role with the necessary permissions and then create a new user account.

Note

Only **admin** users can create other admin role users.

Roles and users can be added and configured in **Settings**, on the **Users** tab.

There are two types of users: local (stored in the Server database) and [LDAP](#) (see [Connecting LDAP users](#)).

To enable LDAP users, you must configure access to LDAP catalogs.

The actions of all system users are recorded in the system log (see [The System Log](#)).

Note

The following user actions are logged:

- Client started/quit
- Settings for hardware, archive, or detection tool are deleted/added or changed
- Macros are created, deleted, or changed
- User permissions are added, deleted, or changed
- Camera alarm is initiated
- Camera is armed/disarmed
- Create / edit comments
- Snapshot or video is exported
- PTZ

In all user-specific events, the user IP address is indicated.

Date & time	Event type	Description
28/08/2020 17:38:27	Audit	Device "2.Face" of server "DESKTOP-PDDDG3B": Alarm initiated by user "admin"/"root" from IP address "192.168.15.9"
28/08/2020 17:38:26	Audit	Viewing of camera "2.Face" by user "admin"/"root" from IP address "192.168.15.9"

7.6.1 Creating and configuring roles

A role is intended for assigning a group of users individual rights and permissions for administration, management and/or monitoring of individual components of Axxon Next.

To register a new role, perform the following:

1. At the end of the list of system roles, click the **Create** link.

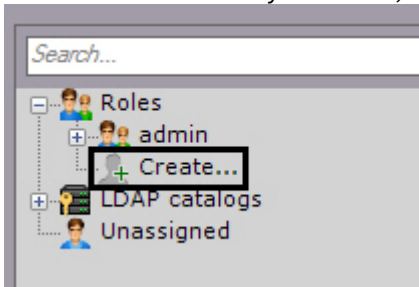

The new role is added in the system, with its properties displayed on the right side.

2. Enter a name for the role in the corresponding field (1).

Role	Role	
Basic		
Name		1
Map control		
Map management	Full access	2
Other		
Archive depth viewing restriction		3
Access to Functions		
Access to Search in archive mode	Yes	
Adding camera to layout in monitoring mode	Yes	
Adding/editing presets	Yes	
Alarms processing	Full access	
Allow comments in archive	Create/Protect/Edit and delete	
Allow to delete records	Yes	
Allow unprotected export	Yes	
Export	Yes	
Layouts editing	Yes	
Minimize to taskbar	Yes	4
Operating domain	Yes	
Permission to access via WebUI	Yes	
Realtime recognition setup	Yes	
Show captions	Yes	
Show faces	Yes	
System log	Yes	
Unlock camera menu button	Yes	
View masked video	Yes	
Access to Settings		
Archive settings	Yes	
Detection settings	Yes	
Device settings	Yes	
Options settings	Yes	5
Programming setup	Yes	
Show error messages	Yes	
User Permission settings	Yes	
Access to Tabs		
Device tree panel	Yes	6
Layouts tab	Yes	
Supervisor confirmation		
Supervisor for access to export		7
Supervisor for authorization in client		
Time schedule management		
Time schedule		8
Video walls management		
SERVER1	Yes	9

SERVER1	Priority	Access
1.Camera	10	Live/Archive/Control/Configure
Архив AliceBlue		Full access

3. Select priority of PTZ cameras control for users with the current role.

4. Select priority of map access for users with the current role (2).

Access level	Description
View only	You can only view maps
View/move/scale	You can move and scale maps
Full access	All options available

5. If you need to limit access of users of a given role to all system archives, you can specify the retention time (archive depth) limit in the **Archive depth viewing restriction** field (3). If no limit is set, users may access the entire Video Footage.

6. Set access permissions for Axxon Next features (4). Access can be restricted to such features as:

- a. Archive search (see [Video surveillance in Archive Search mode](#)).
- b. Adding a camera to a layout in live video mode (see [Adding cameras to cells](#)).
- c. Adding and editing presets for PTZ cameras (see [Creating and editing presets](#)).
- d. Alarms Management (see [Video surveillance in Alarm Management mode](#)).

No access: users have no access to alarm videos. **View only:** users can view alarm videos but they can't evaluate alarms. **Full access:** users can view alarm videos and evaluate alarms

- e. Creating comments (see [Operator comments](#)) and protected records in Video Footage (see [Protecting video footage from FIFO overwriting](#)).

Access level	Description
No access	No comments allowed
Create	Add comments to archives
Create / Protect	Add comments to archives, create protected records

Access level	Description
Create / Protect / Edit / Delete	Add comments to archives, create and edit protected records

- f. Removing videos from the footage archive (see [Delete a part of an archive](#)).
 - g. Allow unprotected export (see [Frame export](#), [Standard video export](#)). Set **No** to require setting a password for exported images and video.
 - h. Exporting snapshots and video recordings (see [Exporting Frames and Video Recordings](#)).
 - i. Editing layouts (see [Configuring Layouts](#)).
 - j. Minimizing the Client to the system tray (see [Interface of the Axxon Next Software Package](#)).
 - k. Managing an Axxon domain (see [Axxon Domain operations](#)).
 - l. Access to the Web server (see [Working with Axxon Next Through the Web Client](#)).
 - m. Displaying captions (see [Viewing titles from POS terminals](#)).
 - n. Show faces (see [Masking faces](#)).
 - o. Viewing the system log (see [The System Log](#)).
 - p. Context menu of a video camera in a viewing tile (see [Viewing Tile Context Menu](#)).
 - q. View masked video (see [Setting up privacy masking in Video Footage](#)).
7. Configure access rights to the **Settings** tabs and to system error messages (5).

Attention!

If you set the **User Permission Settings** parameter to **Device access rights only**, all users of the given role will be permitted to change only access rights to connected devices.

Note

Error messages are displayed in real time in the **Layouts** interface

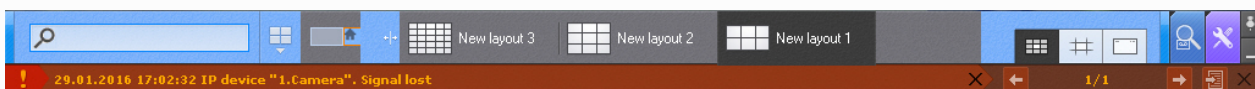

- 8. Set access permissions for **Layouts** in Axxon Next (6). This setting is related to both primary and web clients.
- 9. Set the parameters to apply the four-eyes principle (7):
 - a. If the administrator has to confirm the launch of export for users of this role, select the appropriate role in the **Supervisor for access to export** list.
 - b. If the administrator has to confirm the login of users of this role, select the corresponding role in the **Supervisor for authorization in client** list.
- 10. If you need to grant the users in this role permissions only for a certain period of time, select a Time schedule (8) from the list. These users will not be able to use their permissions outside of the selected time schedule.
- 11. Configure rights to manage connected Clients' monitors by setting permissions for each Server on an Axxon domain (9). A user who has management permissions for the monitors of a particular Server can manage monitors of any Client connected to that Server.
- 12. Set permissions for access to hardware and archives on an Axxon domain (10).

Device	Access permissions	Description
Video camera	No access	You cannot access the device.
	Archive only	You can only view video footage in archive.
	Live in Armed mode	You can view video from the camera only when the camera is armed.

Device	Access permissions	Description
	Live	You can live video from the camera. Other functions and device configuration are not available.
	Live/Archive	You can view live and recorded video from the camera. You cannot arm/disarm/configure the camera.
	Live/Archive/Control	All functions available. You cannot configure the device.
	Live/Archive/Control/Configure	All functions and settings available.
Microphone	No access	The user is unable to listen to live sound from the video camera. The user is unable to listen to sound recordings from the archive.
	Live Audio	The user is able to listen to live sound from the video camera (the microphone must be turned on). The user is unable to listen to sound recordings from the archive.
	Live Audio and Archive	All functions are accessible
PTZ	No access	The user cannot control the PTZ device
	Minimum level	The user can control the PTZ device with the corresponding priority (see Controlling a PTZ Camera)
	Low level	
	Medium level	
	High level	
	Maximum level	
Archive	No access	Access is not provided to this archive
	Full access	Archive is available for all functions

You can configure group rights for accessing devices and archives of a particular Server. To do so, select an access level for the **Server** object. Depending on the level that is chosen, particular access levels are automatically configured for the devices and archives of the relevant Server (see table).

Server access level	Device/archive	Device/archive access level
Custom	-	Access levels for devices and archives are set manually
No access	-	No access to devices and archives
Archive Only	Video camera	Archive only
	Microphone	Live Audio and Archive
	PTZ	Medium level
	Archive	Full access
Live in Armed Mode	Video camera	You can view armed cameras

	Microphone	Live Audio
	PTZ	Medium level
	Archive	No access
Live	Video camera	You can view live video
	Microphone	Live Audio
	PTZ	Medium level
	Archive	No access
Live/Archive	Video camera	You can view live and recorded video
	Microphone	Live Audio and Archive
	PTZ	Medium level
	Archive	Full access
Live/Archive/Control	Video camera	All functions. Settings not available.
	Microphone	Live Audio and Archive
	PTZ	Medium level
	Archive	Full access
Live/Archive/Control/Configure	Video camera	All functions + settings available.
	Microphone	Live Audio and Archive
	PTZ	Maximum level
	Archive	Full access

13. Click the **Apply** button to save the role.

The new role has now been created.

You can copy Roles. To do it, follow the steps below:

1. Select the role to copy.
2. Click **Create**.

This creates a new identical role.

Note

To create an empty user role with no parameters specified, select the **Roles** common group, and click **Create**.

To delete a role, perform the following:

1. Select the role to delete.

2. Click **Delete**.

Note

You cannot delete a role if the user through which you logged into the system belongs to that role.

3. Click the **Apply** button.

The role has now been deleted. All users under this role will also be deleted.

7.6.2 Connecting to an LDAP catalog

To connect to an LDAP catalog:

1. In the **LDAP Catalogs** group, click **Create**.

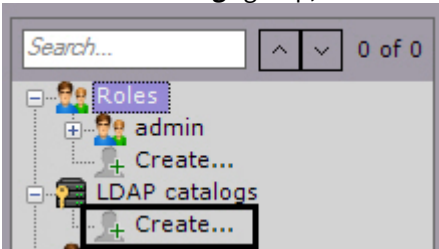

An **LDAP** object is added in the system. On the right, a panel displays configuration settings for the **LDAP** catalog.

2. Enter a name for the catalog in the appropriate field (1).

LDAP settings

1 Name: LDAP 1

2 Server name or IP address: ldap.postland.org Port: 636 3

4 Base DN: ou=Address,dc=itvgroup,dc=ru

User: uid=your.login,ou=Users,dc=itvgroup,dc=ru

5 Password: *****

6 Use secure connection (SSL)

7 Search filter: (objectClass=person)

10 LDAP templates: [OpenLDAP](#)
[Microsoft Active Directory](#)

8 Username attribute: cn

9 DN attribute: entrydn

Role for automatic registration of user:

11

Test connection

3. Enter the address of the LDAP catalog server (2) and port (3).
4. In the **Base DN** field, enter the Distinguished Name of the branch from which to start search (4).

Attention!

If LDAP users are located in multiple directories with a tree-like structure, you cannot establish instant synchronization across all users.

To synchronize each user group within a DN branch, you have to specify the path to the corresponding directory.

For example, LDAP contains a directory **Employees** including subdirectories **Managers**, **Cashiers** and **Salesmen**.

DN branches for synchronizing users within **Managers** directory:

ou=Managers,ou=Employees,dc=example,dc=com.

DN branches for synchronizing users within **Cashiers** directory:

ou=Cashiers,ou=Employees,dc=example,dc=com.

DN branches for synchronizing users within **Salesmen** directory:

ou=Salesmen,ou=Employees,dc=example,dc=com.

5. Enter the name of a user who has write access to the base DN, in LDAP format (RDN + DN) with password (5).
6. If encryption (SSL) is required for connecting to the LDAP server, select the corresponding check box (6).
7. In the **Search filter** field, enter a string for filtering catalog entries (7).

Attention!

To upload users by groups, not by directories, you should use the Member Of filter attribute. For example:

(&(objectClass=user) (memberof=CN=YourGroup,OU=Users,DC=YourDomain,DC=com))

8. In the **Login attribute** field, enter the field from which the user's login is obtained (8).

Note

To search users by attribute **sAMAccountName**, enter their names in small letters - **samaccountname**

9. In the **DN attribute** field, enter the field from which the user's DN is obtained (9).

Note

To set a login and DN attribute, you can use Microsoft Active Directory and OpenLDAP LDAP templates. To use a template, click the relevant link (10).

10. Specify a default user role for users created via LDAP (11). If no role is specified, no automatic user creation will be possible for this catalog.
11. Click the **Apply** button.

The LDAP catalog is now added to the system.

To test the connection, click the **Test connection** button. If connection is successful, the form on the lower part of the screen displays information about the catalog users. Otherwise, an error message appears.

cn	entrydn
alexey dyndalev	cn=alexey dyndalev,ou=qa,ou=Groups,dc=example,dc=com
andrey vasiliev	cn=andrey vasiliev,ou=dev,ou=Groups,dc=example,dc=com
danil serov	cn=danil serov,ou=dev,ou=Groups,dc=example,dc=com
ilya smirnov	cn=ilya smirnov,ou=it,ou=common,ou=Groups,dc=example,dc=com
name1 surname1	cn=name1 surname1,ou=load,ou=Groups,dc=example,dc=com
name2 surname2	cn=name2 surname2,ou=load,ou=Groups,dc=example,dc=com
name3 surname3	cn=name3 surname3,ou=load,ou=Groups,dc=example,dc=com

7.6.3 Working with users

In Axxon Next, multiple users can be assigned to the same role. A user will be granted the permissions for administration, management and/or monitoring that are indicated in the settings of the user's role. When adding a new user, the name and password necessary for that user to log in to the system are specified.

7.6.3.1 Creating local users

To add a new local user:

1. At the end of the list for a particular role click the **Create** link.

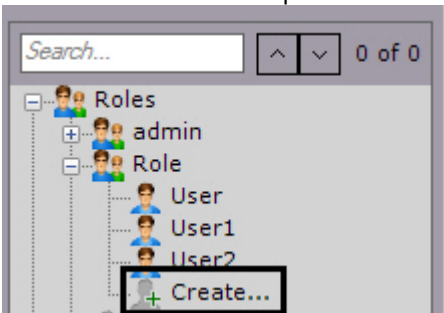

The new user is then added to the system, and the permissions configuration panel for that user opens on the right.

User1	
▼ Basic	
1 Name	User1
▼ Additional	
Comment	
▼ Basic	
Company ID	
Date of creation	14.03.2019 12:26
IP address	
Lock user account	No
2 Role	Role
Social ID	
User e-mail	
▼ LDAP	

2. Enter a user name (**1**).

3. Select the role you want to attribute to the user (2).

User1	
Lock user account	No
Role	Role
Social ID	
User e-mail	
LDAP	
Catalog	
Security	
Change password on next access	No 4
Password	••• 3
Simultaneous connections limitation	
Maximum number of mobile app connectic	
Maximum number of web app connections	5

4. Enter the password in the **Security** configuration group (3).

- a. Click . The **Change password** window opens.

Change password

New password:

Confirmation:

- b. Enter the user's assigned password in the **New password** field.
 c. Retype the assigned password in the **Confirmation** field.
 d. Click **OK** to save the settings.

5. To force a user to change the password upon the next connection to the Client, set the corresponding parameter (4) to **Yes**.

6. If you want to limit the number of connections for a user through Web or mobile clients, do as follows: specify a maximum number of connections (5). The **Maximum number of web app connections** parameter also sets a limit on maximum number of RTSP queries from a particular user.

Attention!

The limit on the number of connections will take effect after the server is restarted (see [Launching and Closing the Axxon Next Software Package](#)).

7. If necessary, enter additional information about the user (e-mail, IP address, personal and company ID, etc.) in appropriate fields.
 8. Click the **Apply** button to save the settings.

The user has now been added and assigned a role.

7.6.3.2 Locking a user account

You can lock user accounts to prevent unwanted logins.

To do this:

1. Select a user account (1).

2. In the **Lock User Account** field, select **Yes** (2).
3. Click **Apply**.

To unlock an account, select **No** in the **Lock User Account** field.

7.6.3.3 Creating LDAP connections

When adding an LDAP user, the user's login is selected from the specified LDAP catalog. No password is required.

To add an LDAP user:

1. Add the user to the system (see [Creating local users](#)).
2. Select the LDAP catalog that contains the user (1, see [Connecting to an LDAP catalog](#)).

- In the **Login** field, click the button (2).
A window with all users of the LDAP catalog opens.

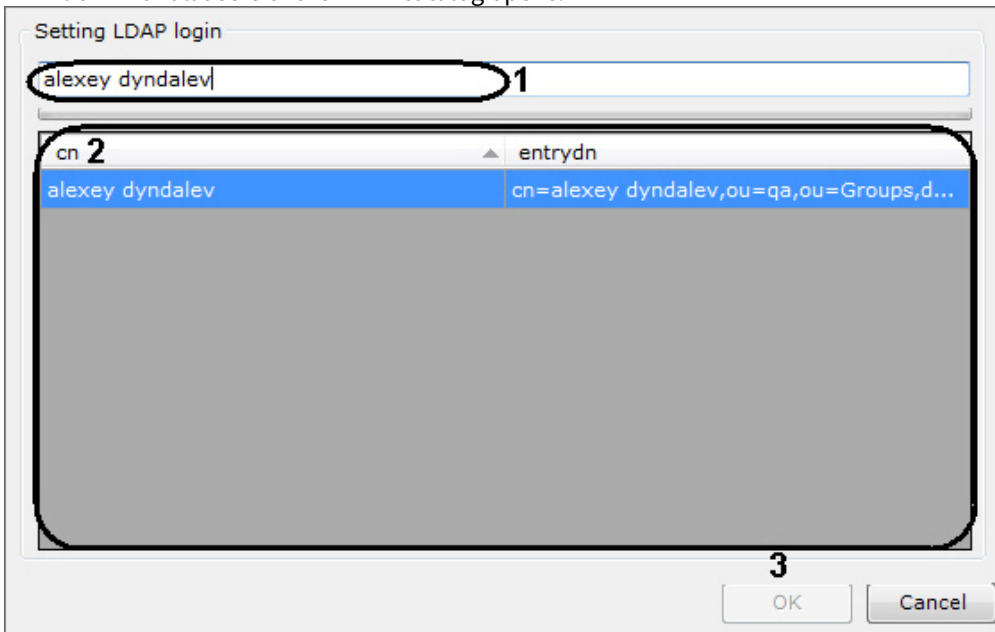

- Find a user via search (1) or manually select a user from the list (2). Click **OK** (3).
- Specify the other user settings (see [Creating local users](#)).
- Click the **Apply** button to save the settings.

The user has now been added and assigned a role.

When an LDAP user connects, the user's login from Server settings is used with the password from the LDAP catalog.

7.6.3.4 Synchronize LDAP users

To add users from an LDAP directory to a specific role, do as follows:

- Right-click the role to which you want to add users.

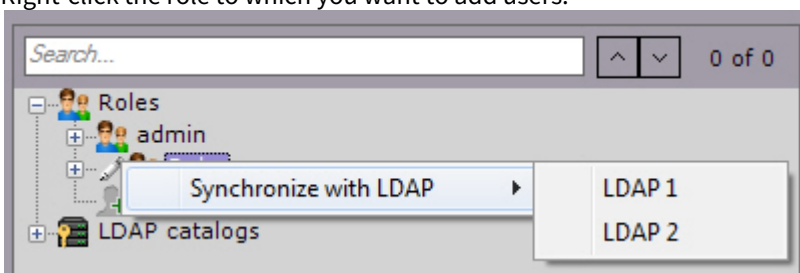

- Choose **Synchronize with LDAP** and then the required LDAP directory (see [Connecting to an LDAP catalog](#)).

All users in the selected directory will be added to this role. By default, the user name will match the login in the LDAP directory.

7.6.3.5 Deleting users

To delete a user from the tree:

- Select the user to delete.
- Click **Delete**.

Note

You cannot delete the user through which you logged into the system.

- Click the **Apply** button to save the settings.

The user has now been deleted from the tree.

Attention!

If you delete a user account on the LDAP server, it will be automatically deleted from *Axxon Next VMS*.

7.6.4 Configuring the user security policy

To configure the user security policy, do as follows:

1. Go to **Settings -> Options -> Security Policy (1-2)**.

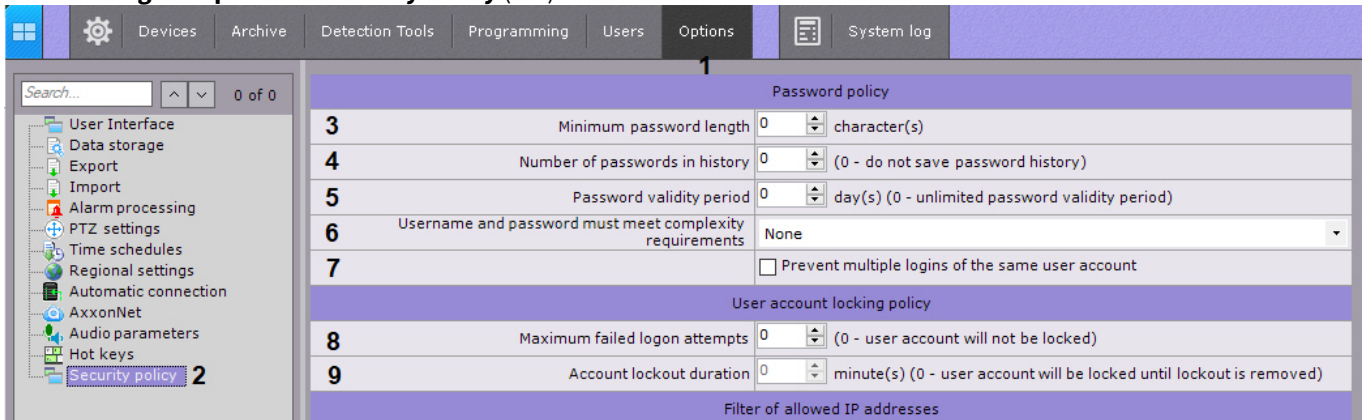

2. Set the minimum password length (3).
3. Set the number of most recent passwords for each user to be stored (4). 0 – do not store password history. If this value is non-zero, passwords stored in history may not be reused.
4. Set password expiration time interval in days (5). After the time interval expires, the user will be prompted to set a new password. 0 – the password never expires.
5. Select positions to meet complexity requirements: nothing, password only, user name and password (6).
The requirements:
 - a. user name:
 - i. must contain no less than 6 characters and at least 2 digits;
 - ii. must not include common role names, such as: admin, administrator, administrator1, root, super, superuser, supervisor.
 - b. The password has to contain at least 8 characters, which must meet at least 3 requirements listed below:
 - i. at least 1 capital letter;
 - ii. at least 2 lowercase letters;
 - iii. at least 3 digits;
 - iv. at least 4 special characters, such as: !\"#\$%&'()*+,-./:;<=>?@[\\]^_`{|}~
6. If you need to limit the number of sessions per user to one, check the corresponding box (7). This requirement also applies to web and mobile Clients.
7. Set the number of failed login attempts to lock a user's account (8). 0 – no account locking on incorrect passwords.

Attention!

When unblocked, the user is offered only one authentication attempt. A successful authentication will reset the failed attempts counter to zero, otherwise the user account will be blocked again.

8. Set the duration of user account locking on failed login attempts, in minutes (9). 0 – the account can be unlocked by the administrator only.
9. Click **Apply**.

Attention!

If any user accounts created in your system before you applied changes in security policy are incompatible with the new requirements, the users will be prompted to change their credentials upon their next login.

7.7 Configuring Layouts

Axon Next allows users to configure custom layouts.

Separate layouts are configured for each user of the system. To configure layouts, log into any Server of Axon-domain under the appropriate user name and configure the layouts for that user. Layouts created for the user will be available when you connect from any Client to any Server in the Axon-domain. The layout is selected for display and editing only for a specific user - other users of the system will not see any changes on their screen.

Note

Creation, editing, copying, and deletion of layouts are available to users that belong to roles with the **Changing custom layouts** component activated (see [Configuring user permissions](#)).

After you configure a user's layouts, you may want to limit that user's privileges.

7.7.1 Creating and deleting layouts

Layouts are created based on standard layout types. To create a new layout, click the  button in the context menu and select one of the standard layouts.



This takes you to layout editing mode (see [Switching to layout editing mode](#)).

Note

A new layout is also created when you select a video camera that is not displayed in any previously created layout (see [Objects Panel](#), [Camera Search Panel](#)).

If you do this, layout editing mode does not start and the layout will not be saved.

The newly created layout will be named automatically. You can rename it later.

To save the layout, exit layout editing mode and save changes (see [Exiting layout editing mode](#)).

The layout will then be placed at the beginning of the list in the layout panel.

If you do not save changes and exit, the layout will not be saved.

To delete layouts:

1. Select **Delete/Move layouts** in the context menu.

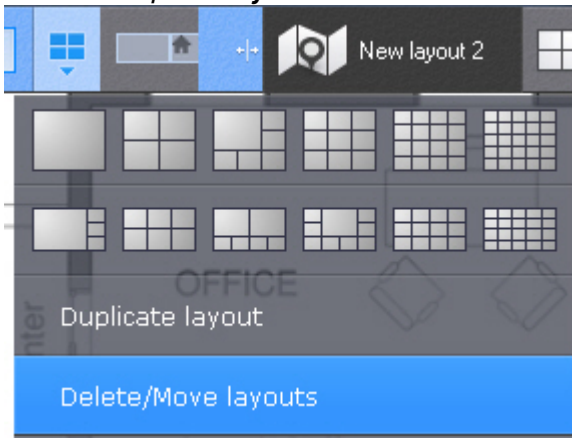
**Note**

You can not access it in the Layout Editing mode though.

2. Click the  button to delete layouts.
3. Click **Save**.

You will exit **Manage Layouts** mode and save changes.

The layouts have now been deleted.

7.7.2 Rename Layouts

To rename a layout, double left-click and enter a new name.

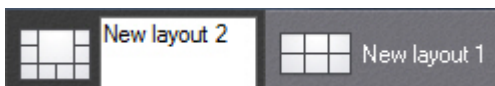

You can rename layouts in Manage Layouts mode either.

Using the "\" symbol in the layout name, you can build a layout tree in the Object Panel (see [Objects Panel](#)).

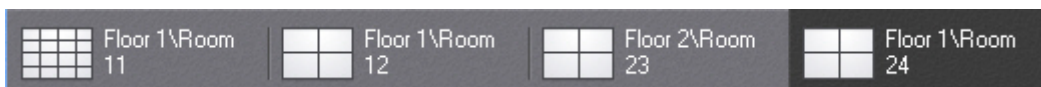

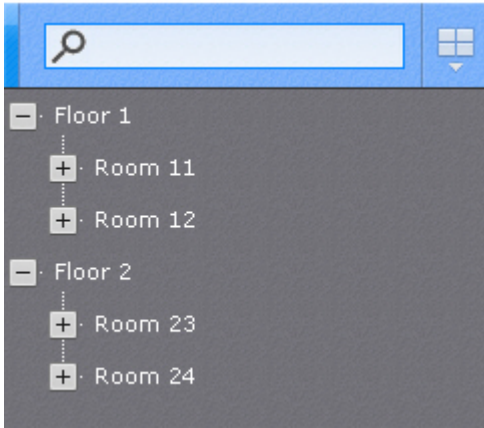

7.7.3 Reorder Layouts

To reorder layouts in the ribbon:

1. Go to Manage Layouts mode (see [Creating and deleting layouts](#)).
2. Drag & drop layouts
3. Click **Save**.

You have now reordered layouts.

7.7.4 Layout copying

You can copy existing layouts.

Select the layout that you want to copy. Click the  button to open the context menu and select **Duplicate layout**.

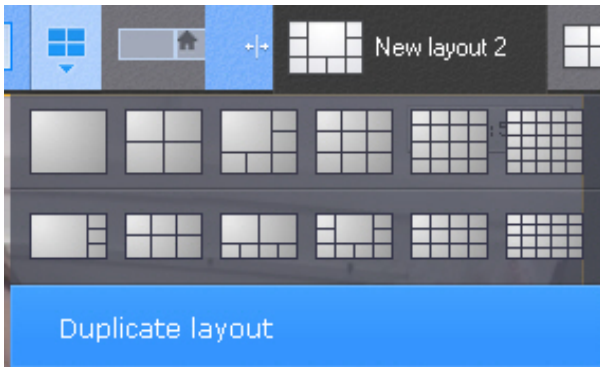

An identical layout is then created.

Note

Layouts cannot be copied while in editing mode

7.7.5 Editing layouts

Every layout consists of cells, which are viewing portals that can hold either video cameras or information boards.

Axon Next offers 5 types of information boards that can be added to layouts:

1. Events Board.
2. Health Board (for servers and cameras).
3. Statistics Board.
4. Dialog Board.

5. Web Board

Information boards are available on the layouts ribbon in editing mode.

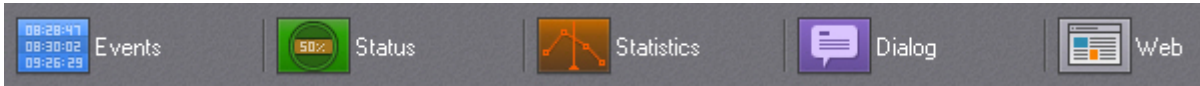

When a camera is added to a cell, a viewing tile appears.

7.7.5.1 Switching to layout editing mode

When you create a layout, you are automatically taken to the layout editing mode. Alternately, you can click the  button and select **Edit layout / map** in the context menu of the layouts ribbon.

Note

To use layout editing mode, you must have required permissions.

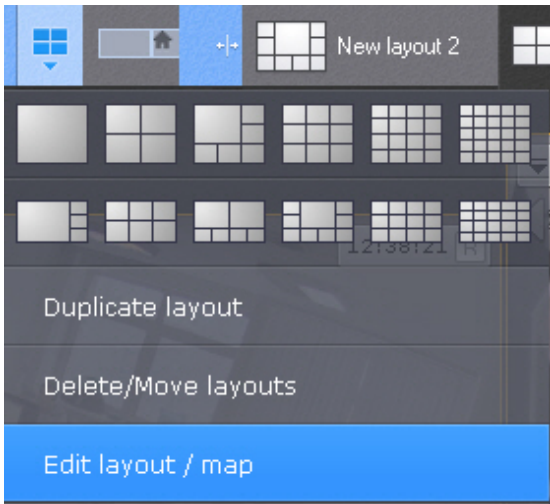

In layout editing mode, space is divided by a grid of equal-sized squares for holding viewing tiles (1).

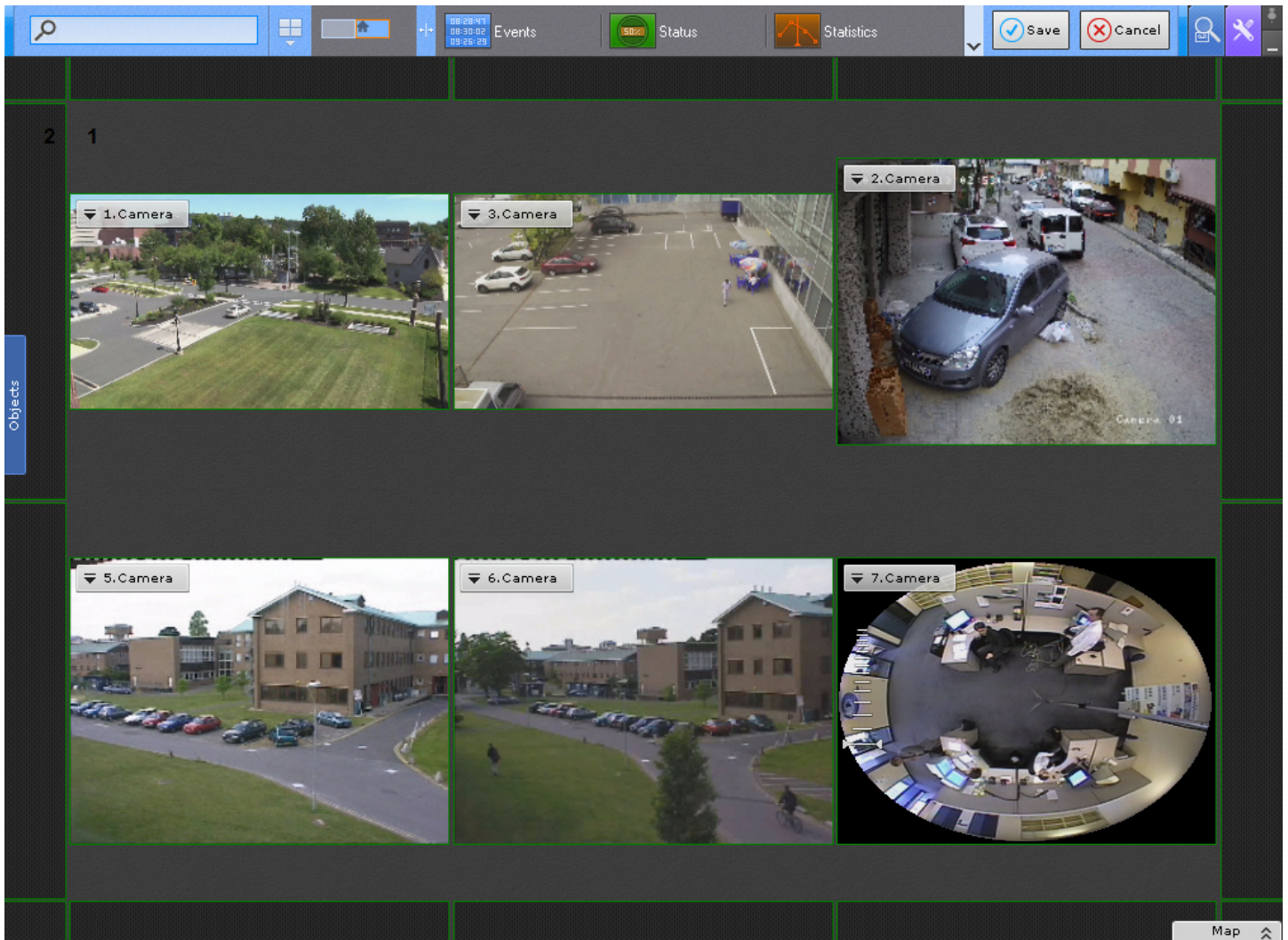

On the edge of the layout there are grid square fragments (**2**), which are parts of ordinary empty cells and allow adding new cells to the layout (see [Adding new cells to a layout](#)).

7.7.5.2 Selecting a layout for editing

To edit a layout, do as follows:

1. Go to the layout you want to change (see [The Layouts panel](#))
2. Switch to the Layout Editing mode (see [Switching to layout editing mode](#))

Otherwise, select a layout for editing in the layouts ribbon. You can also use layout editing mode to create a new layout (see [Creating and deleting layouts](#)) for editing.

7.7.5.3 Configuring layout cells

7.7.5.3.1 Adding new cells to a layout

Switching to layout editing mode

You can add new cells to a layout in one of three ways:

1. Drag a non-empty cell onto a grid square fragment (see [Moving cells](#)).
2. Left-click a grid square fragment and resize it (see [Resizing cells](#)).
3. Left-click a grid square fragment and select a video camera or information board in it (see [Adding cameras to cells](#)).

Cells are added in rows. For example, when editing a six-square (3*2) layout, a column of two grid squares is added when a fragment is chosen on the left or right side of the screen.

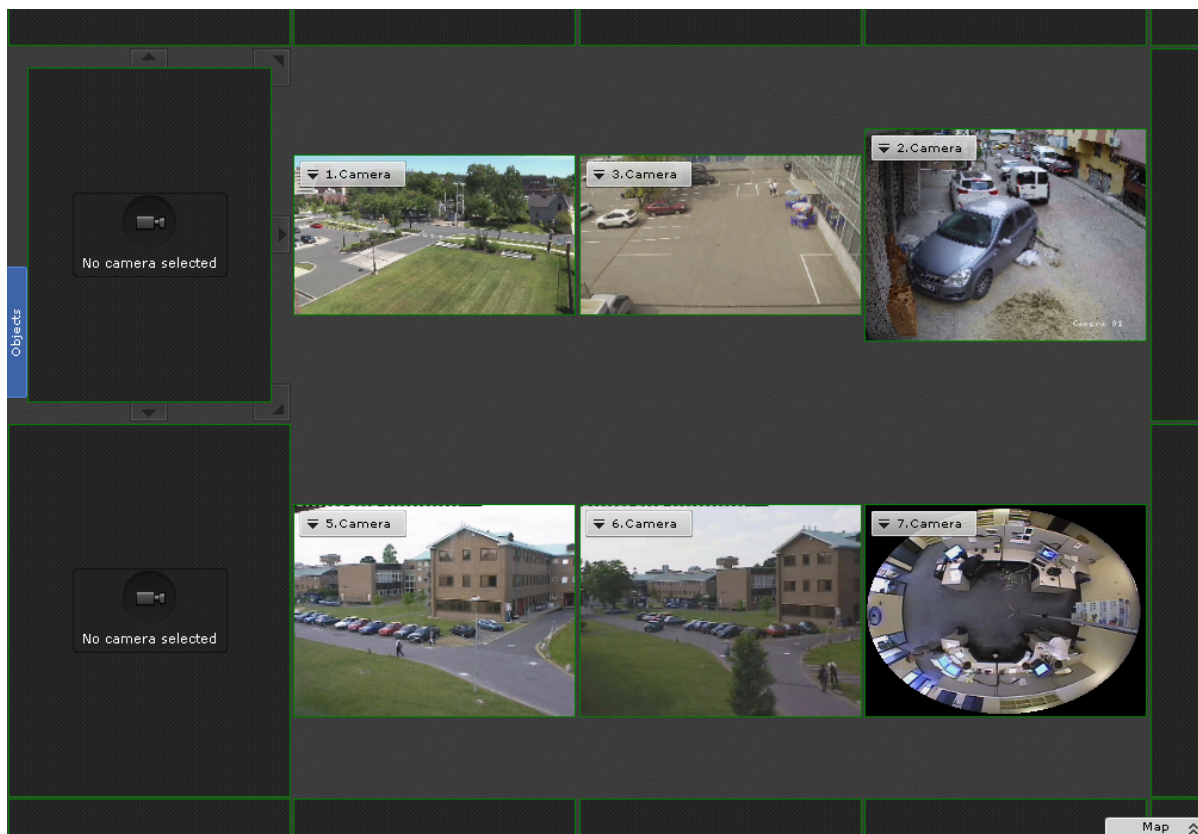
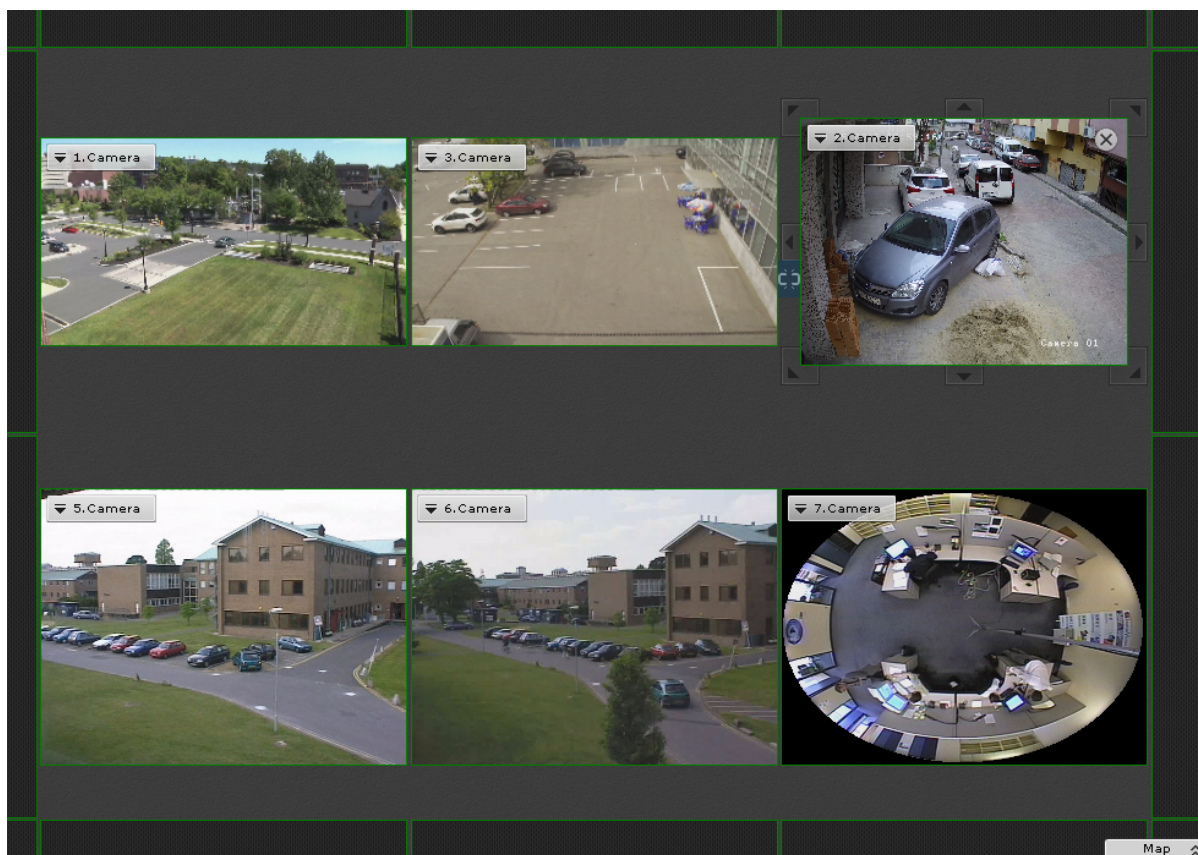

A row of three squares is added when you select a fragment from the upper or lower part of the screen.

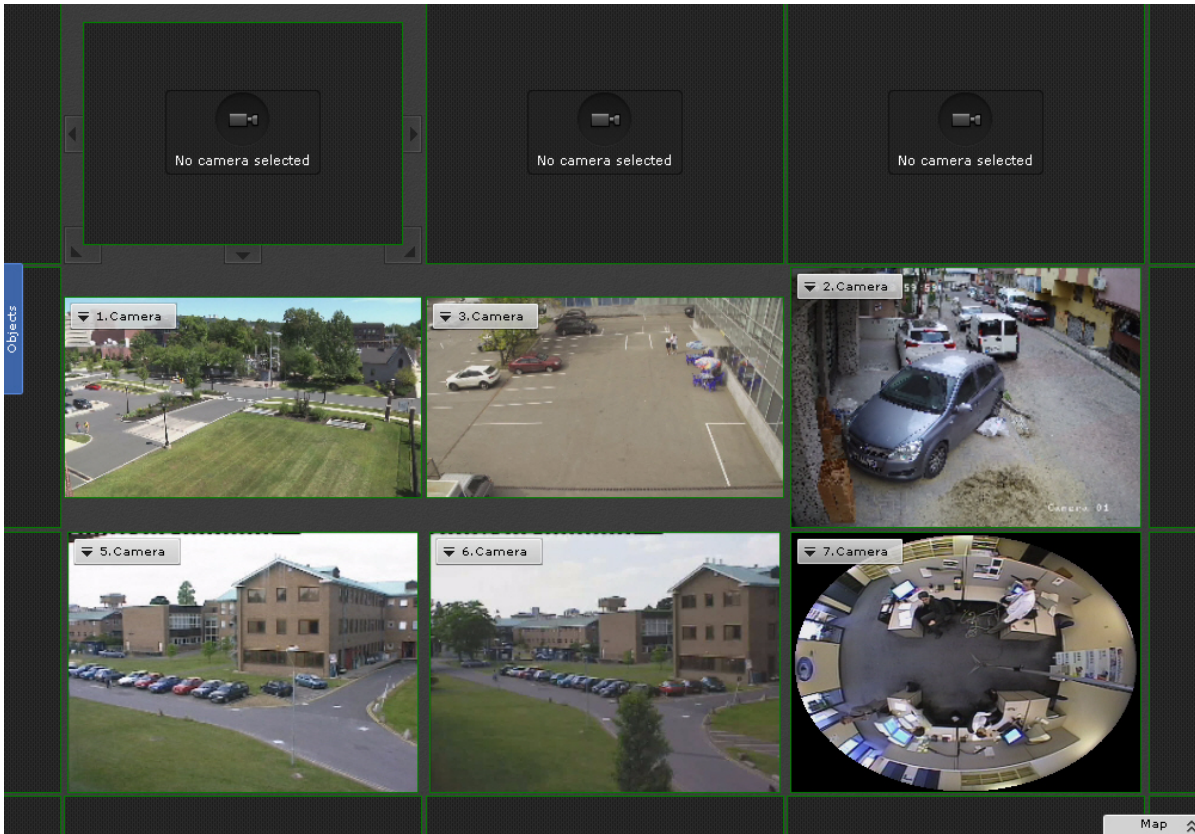



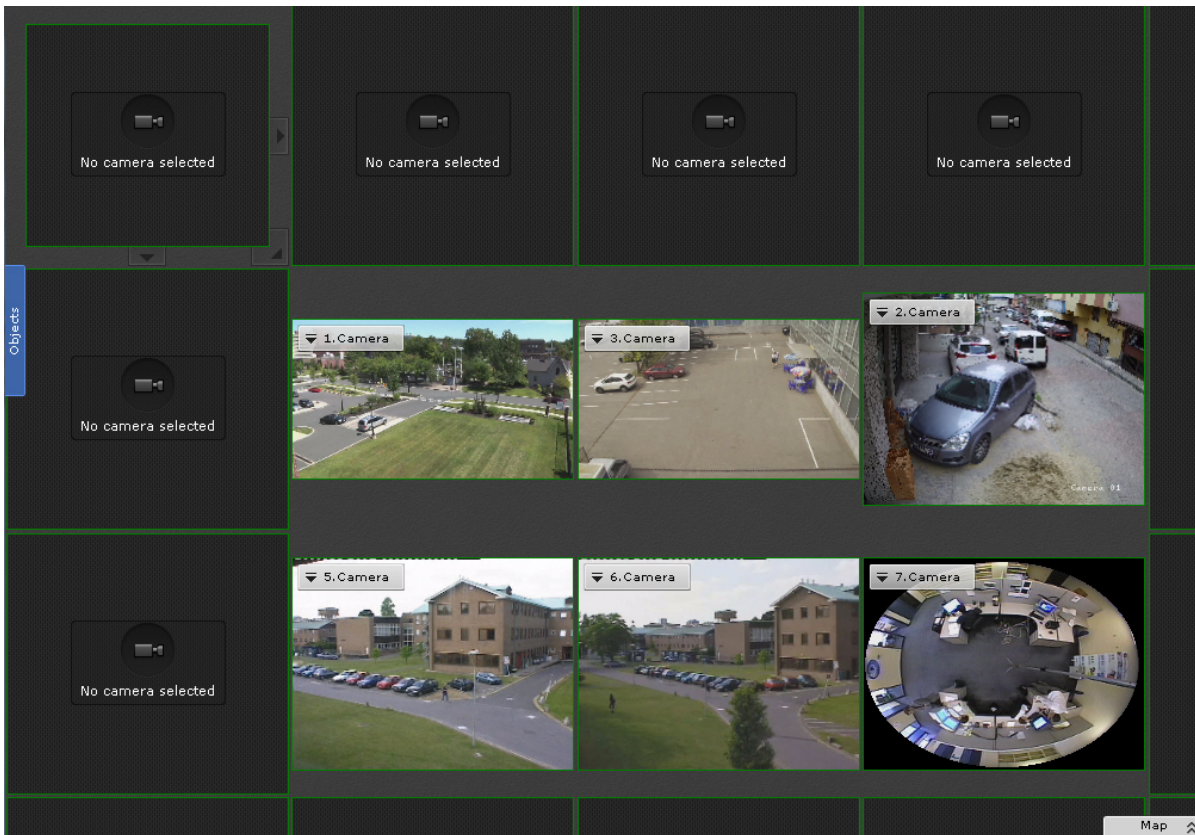





When you select a corner fragment, both a row and column are added.



7.7.5.3.2 Resizing cells

Switching to layout editing mode

To resize a cell, use the buttons on its edges.

Button	Action	Button	Action
	Increases the cell by a column to the left and row above		Increases the cell by a column to the right and row below
	Increases the cell by a column to the left		Increases the cell by a column to the right
	Increases the cell by a column to the left and row below		Increases the cell by a column to the right and row above
	Increases the cell by a row below		Increases the cell by a row above

When you point the cursor at any button, a darkened area that shows the size of the cell after resizing is displayed.

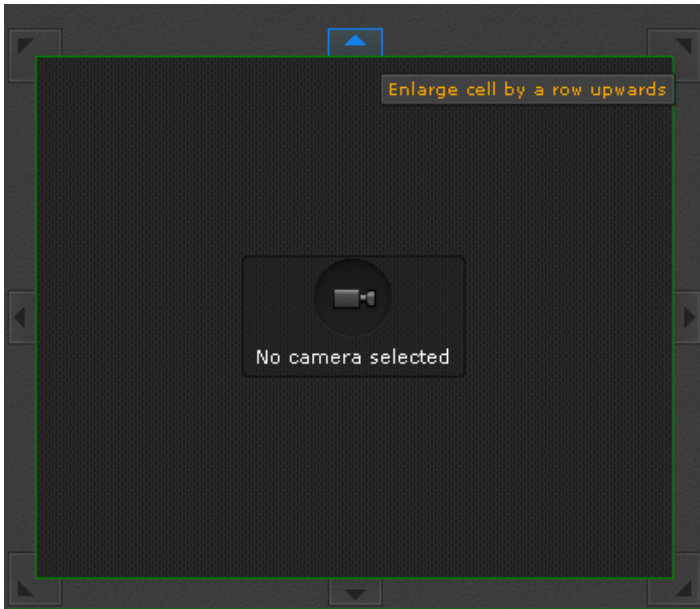

You can also select and resize any tile. To resize, click the button on the cell border and expand / contract the cell as you wish. You can resize the cell only in one direction. You cannot resize the cell in two directions with the corner buttons.

If you expand a tile, the neighboring tiles contract and vice versa.

Note
 If the cell is in the outermost top / bottom row or left | right column, you cannot resize it by clicking and dragging the borders. You should add an extra cell to the current row or column first

Attention!
 If you expand the cell over the next one or several cells, they are deleted.

7.7.5.3.3 Moving cells

[Switching to layout editing mode](#)

To move a cell, left-click the frame of the grid square fragment and drag it to the necessary position.

The cells are then switched: the contents of the previously occupied cell are moved to the location of the cell being moved.

If a cell is moved to a grid square fragment, new cells are added to the layout (see [Adding new cells to a layout](#)).

7.7.5.3.4 Adding cameras to cells

[Switching to layout editing mode](#)

There are two ways to add a video camera to a cell:

1. Using the Objects Panel;
2. Using the Camera Search Panel.

A video camera can be added to an empty cell or to a cell containing an information panel or another video camera.

Note

Cameras from any Axxon-domain can be added to the layout.

Note

The same video camera can be added to several cells of the same layout.

Adding a Video Camera Using the Objects Panel

To add a video camera using the Objects Panel, perform the following steps:

1. Switch the cell to the active mode (with a mouse click).
2. Click a video camera in the Objects Panel (see [Objects Panel](#)).

To add multiple cameras to a layout, do the following:

1. In the objects pane, shift-click several cameras to select.
2. Left-click on any selected camera.
3. Drag the icon onto the layout.
4. Release the mouse button.

You can use the Object Panel for adding all cameras within a group / Axxon domain to the layout. To do it, follow the steps below:

1. left click on the group / Axxon domain in the panel;
2. while keeping the mouse button pressed, move the cursor to the layout;
3. release the mouse button.

Adding a Video Camera Using the Camera Search Panel

To add a video camera to a cell, perform the following steps:

1. Switch the cell to the active mode (with a mouse click) and select a video camera from the list in the Camera Search Panel (see [Camera Search Panel](#)).
2. Select a video camera from the list in the Camera Search Panel with the mouse pointer and, holding down the mouse button, move the pointer into a cell. Then release the button.

7.7.5.3.5 Adding information boards to cells

Switching to layout editing mode

You can add information boards to cells in two ways:

1. Activate the cell (by clicking it) and select the information board that you want to add to the cell.
2. Click an information board to select it. Drag the information board to the layout cell and then release the mouse.



You can add an information board to an empty cell or to a cell that contains a camera or other information board.

Note
After you add an information board to the cell, you should configure it (see [Configuring information boards](#)).

7.7.5.3.6 Linking cells

Switching to layout editing mode

You can link cells.

To create a link, select a cell and click the  button on the border. To delete the link, click .



You can create the following links:

1. A viewing tile to a viewing tile. You can link cells from the same row only. This way you can hide cell borders in live view and have a virtually merged FoV from several cameras.



2. An information board to viewing tile. This way you can link adjacent cells, up / down and across. A single information board can be linked with multiple cameras. If the viewing tile is linked to Event Board, you can click an event and switch to the Archive mode (see [Switching a camera linked to an Events Board to the archives](#)).

- Also, you can link 2 information panels or empty cells to panels (see [Configuring Alerted Cameras layouts](#)).

All linked cells have a different scaling logic (see [Scaling the Viewing Tile](#)).

7.7.5.3.7 Merging videos from adjacent cameras (FrameMerge)

Switching to layout editing mode

FrameMerge stitches video feeds from neighboring cameras into a single panoramic view.

The resulting video is available:

- as live video feeds,
- as recorded footage,
- as exported video files.

Attention!

The maximum horizontal resolution of exported video is 8184 pixels.

To use this option, cameras and their video feeds must match the following conditions:

- Install cameras as close to each other as possible.
- No more than 3 cameras' feeds can be merged horizontally.
- The cameras must have:
 - pixel resolution of no less than 640 * 480;
 - identical aspect ratio for the high and low bitrate streams;
 - identical parameters of lenses.
- You have to synchronize time on all cameras (for example, via NTP protocol).
- Camera jitter must not result in more than 1% image shift in both directions.
- The recommended image overlap across adjacent cameras is 20–25 percent of image width.
- Camera images must be aligned vertically.

For best results in merging, ensure the following:

- Daylight illumination.
- Sufficient light to capture small details.
- No over-exposed areas within the scene.
- Minimum video noise and compression artifacts.
- Moving objects must be visually separated within the FOV.
- Same set of objects in overlapping areas.

Attention!

If overlapping areas are plain monochrome (e.g. the sky), no merging is possible.

To configure video merging, do the following:

- Place the cameras horizontally within the layout.

2. Link the corresponding cells to each other (see [Linking cells](#)).



3. If you need to display a sub-area of the merged video in a separate window, do the following:
- Add a dialog board to the layout (see [Configure the Dialog Board](#)).
 - Configure the panel to display the selected camera.
 - Link the panel to the merged video.

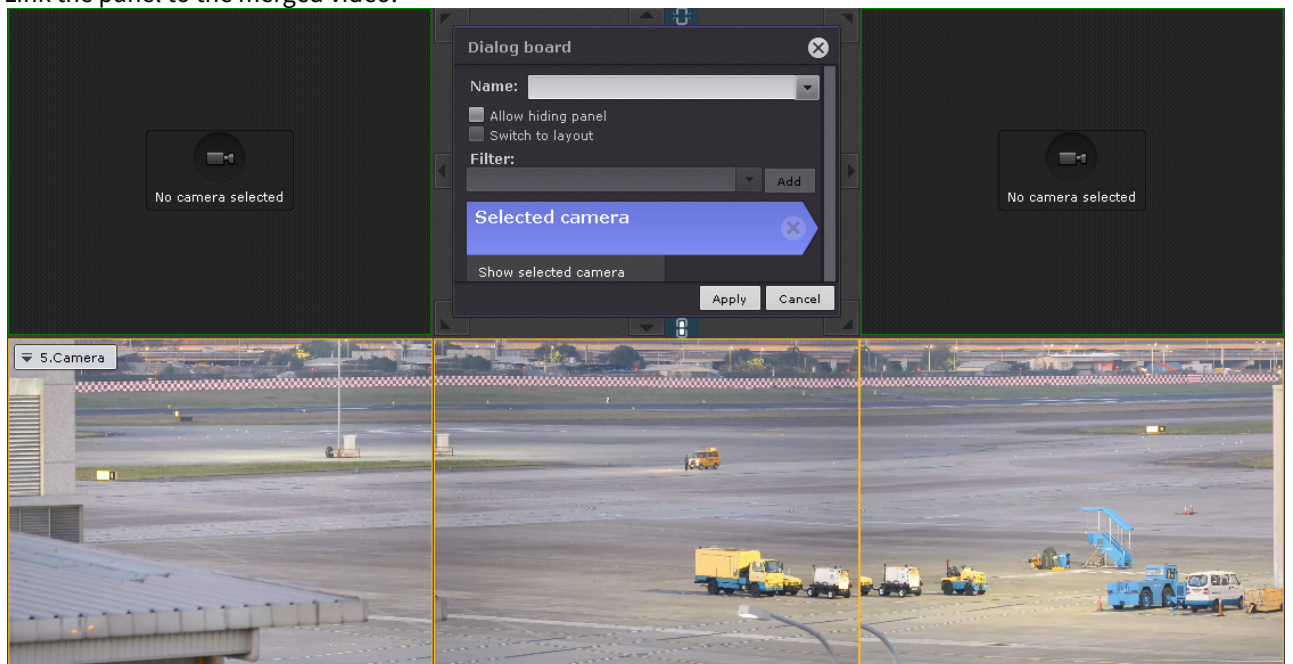

4. Save the layout.

While merging video feeds, the system automatically scans images from adjacent cameras for appropriate stitching points.

The resulting image will be displayed in a single viewing window. If you select a rectangular area within the video image (as for Area zoom function, see [Control using Areazoom](#)), the cropped image appears in the dialog board.

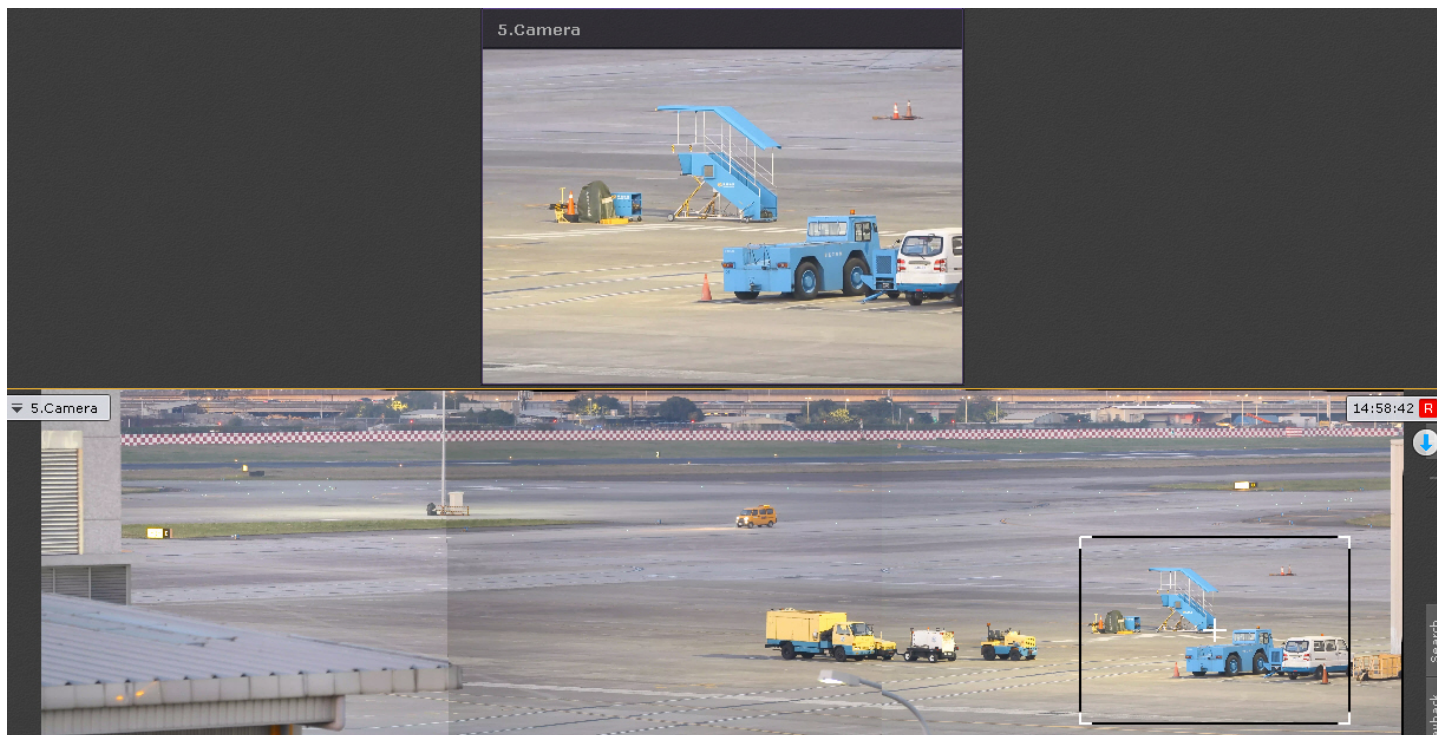

Attention!
 Do not move or reposition cameras after merging their video feeds.
 If any of the cameras change its position, you have to reconfigure the merging.

7.7.5.3.8 Clearing cells

[Switching to layout editing mode](#)

To remove an information board or camera from a cell, in the upper-right corner, click the  button.

If clearing cells in a row or column removes content from all of these cells, the entire row and/or column is removed from the layout.

7.7.5.4 Configuring viewing tiles

7.7.5.4.1 Selecting default functions for viewing tiles

[Switching to layout editing mode](#)

Default values for video stream quality, object tracking, autozoom, and video display (contrast, focus, deinterlacing and flip) functions can be set for viewing tiles.

After the user switches to a layout, these functions are activated automatically.

To set a function as a default one, activate it during layout editing mode (see [Selecting video stream quality in a viewing tile](#), [Tracking objects](#), [Autozoom](#), [Video image processing](#), [Selecting viewing mode for videos from a fisheye camera](#)) and save changes before exiting the mode.

7.7.5.4.2 Select the default video stream for each camera within your layout

Switching to layout editing mode

Use the upper panel to select the default video stream for all cameras within the layout:

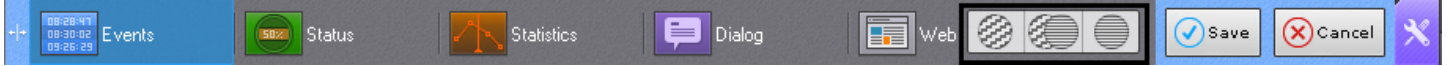

 - low quality stream.

 - GreenStream. The default setting for video stream is low-quality. Upon selection of a Camera Window, the highest resolution stream is displayed by default. After you switch to another Camera Window, the inactive camera window returns to lower resolution / fps display

 - high quality stream.

7.7.5.4.3 Selecting the default video mode for a camera

Switching to layout editing mode

By default, when you switch to a layout, all video cameras are in real-time / live viewing mode.

You can select a default video mode for each camera: real-time mode or archive mode.

Note
This function is not available if the camera is not attached to an archive.

To select a default video mode, in the context menu of the viewing tile, select **Viewing mode** and select the necessary mode.

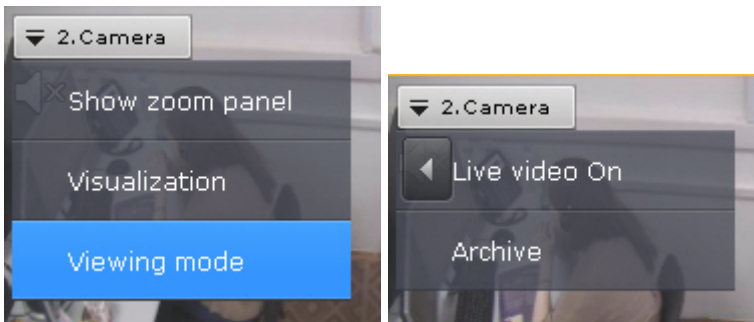

If archive mode is selected, when you switch to the layout, the camera is immediately in archive mode.

7.7.5.4.4 Moving input and output icons in a viewing tile

Switching to layout editing mode

You can move input and output icons in a viewing tile.

To do so, left-click the input or output icon and drag it to the place in the viewing tile where you want to put the icon.

7.7.5.4.5 Configuring default zoom levels (the Fit screen function)

Switching to layout editing mode

The Fit screen function allows displaying a viewing tile by default so that it occupies all of the available space on the screen (full screen). The default zoom level for full screen display is calculated automatically as a minimum zoom value that allows filling the available screen space with the viewing tile contents.

To enable the Fit screen function for a specific video tile, display the digital zoom controller (see [Digitally Zooming Video Images](#)), click the  button on it, and save changes when exiting editing mode.

Note

To disable the Fit screen function, click the  button again.

To enable the Fit screen function for all video tiles on the layout open the context menu and select **Image size adjustment**.

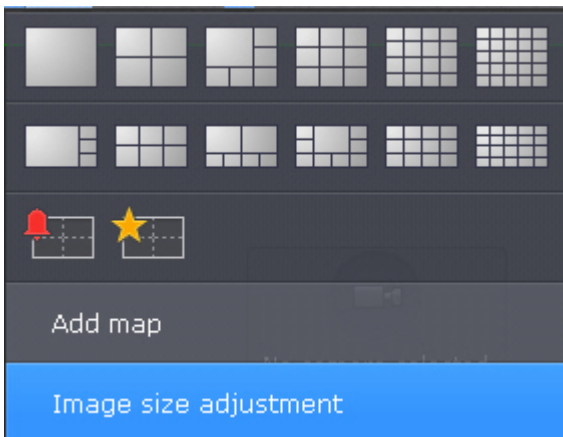

Note

To disable Fit screen across all layouts reselect **Image size adjustment**.

Now when a user switches to this layout, the video in the viewing tile is displayed at the calculated minimum necessary level of digital zoom and the viewing tile occupies all available space.



7.7.5.4.6 Configuring pan/tilt angle for video cameras with Immervision lenses in 180° Panorama display format

Switching to layout editing mode

You can set the pan/tilt angle for fisheye cameras in 180° Panorama display format when switching to a layout.

This is useful when needing to display the entire viewable area in the layout (two areas of 180° each). In this case, the video camera is added twice but with different viewing angles.

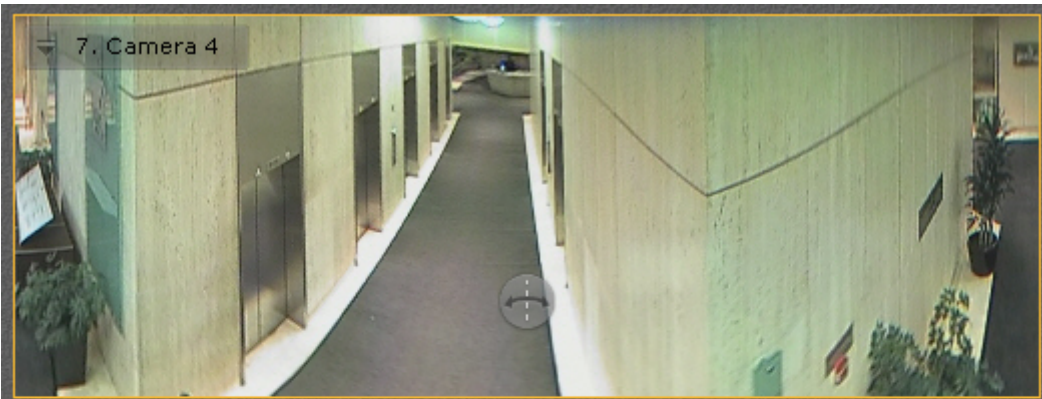

To set the viewing angle, click and hold the  button (see [180 degree Panorama](#)).

7.7.5.4.7 Configuring display of water level detection

Switching to layout editing mode

If you have created a water level detector for a camera (see [Configuring water level detection](#)), you can see the water level sensor in the camera window.

You can also display numerical value of current water levels for the detector. To do it, follow the steps below:

1. In the text field, enter "Water level: {0}". To configure fonts, click .

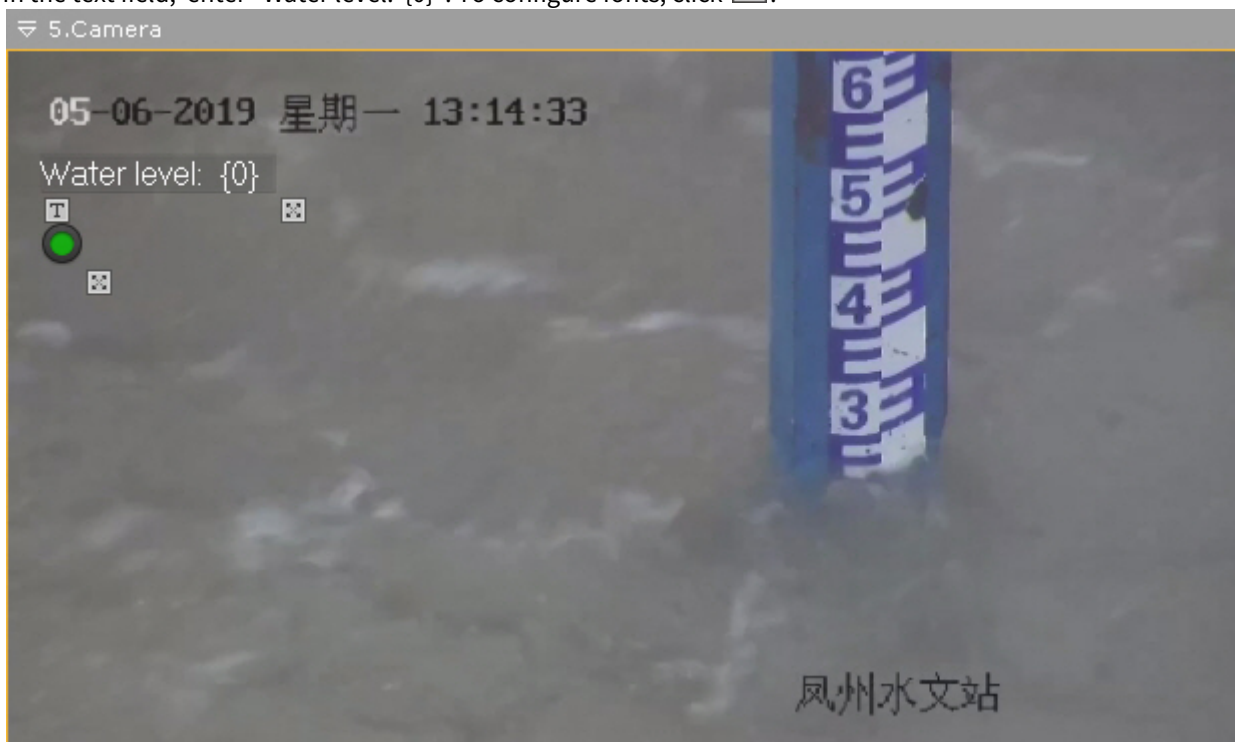

2. Use  buttons to scale up / down the text and the sensor icon.
3. You can move the sensor just as any other object (see [Moving input and output icons in a viewing tile](#)).

When the layout is saved, you see the information displayed in the camera window.

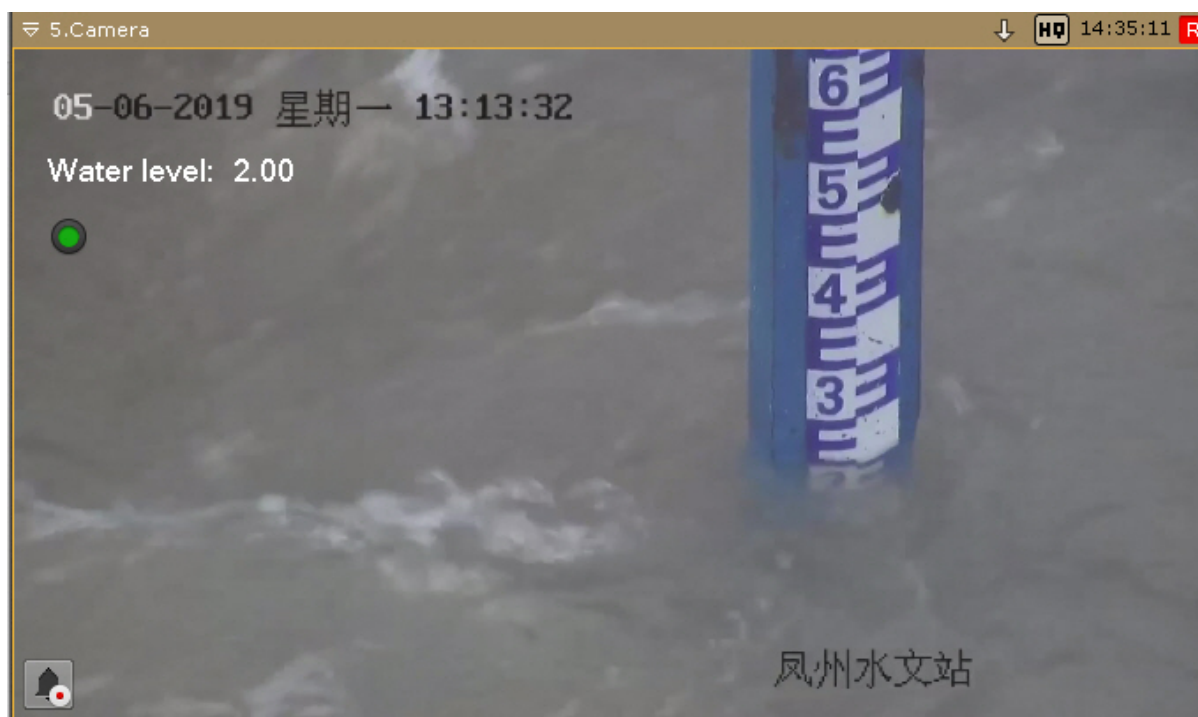

7.7.5.4.8 Adding links to other cameras to the Camera Window

Switching to layout editing mode

You can add links to other cameras to the Camera Window. If you click on such a link, you go to the corresponding camera's window (see [Switching to other camera via a link in the Camera window](#)).

To add a link, do the following:

1. While holding the Ctrl button on your PC keyboard, left-click the camera icon on the Objects panel (see [Objects Panel](#)), and drag it into the Camera window.

A link will be added to a window as a thumbnail .

2. To rotate the thumbnail, click . Each click rotates the thumbnail by 45°.



Note

If you add a text note to the link (see 3), the thumbnail disappears after you rotate it by 360°, and you will have just the text to switch to another camera.

To bring back the thumbnail, click .

Note

To remove the link, click the  button.

3. If required, you can add a text comment to a link via the appropriate text field. To set font attributes, click the  button.
4. Use  buttons to scale up / down the text and the thumbnail.
5. You can move the link just as any other object (see [Moving input and output icons in a viewing tile](#)).

When the layout is saved, you see the newly created link in the camera window.



7.7.5.5 Configuring information boards

7.7.5.5.1 Configuring information board templates

[Switching to layout editing mode](#)

To save information board parameters as a template, specify a name when configuring an information board.



If a name is not specified for the information board (it is not necessary to specify one), no template with the information board parameters is saved or made available when creating new information boards.

When configuring a new information board, you can use previous templates for the type of information board in question by selecting one from the **Name** list.

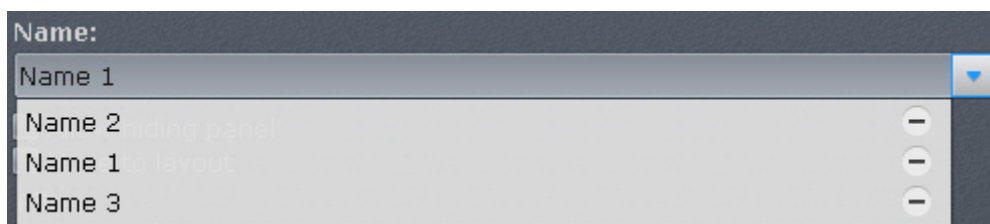

If you save the new information board with the same name, the template parameters are updated and all information boards based on the template are updated as well.

To delete a template, in the **Name** list, click the  button across from the template. The parameters of information boards based on the deleted template are saved, but their names are discarded.

7.7.5.5.2 Configuring Events Boards

[Switching to layout editing mode](#)

Events Boards display some or all system events.

To configure an Events Board:

1. Add an information board to the layout (see [Adding information boards to cells](#)).
2. In the upper-right corner, click the  button.

- To allow operators to hide the information board, select the **Allow hiding panel** check box (1).

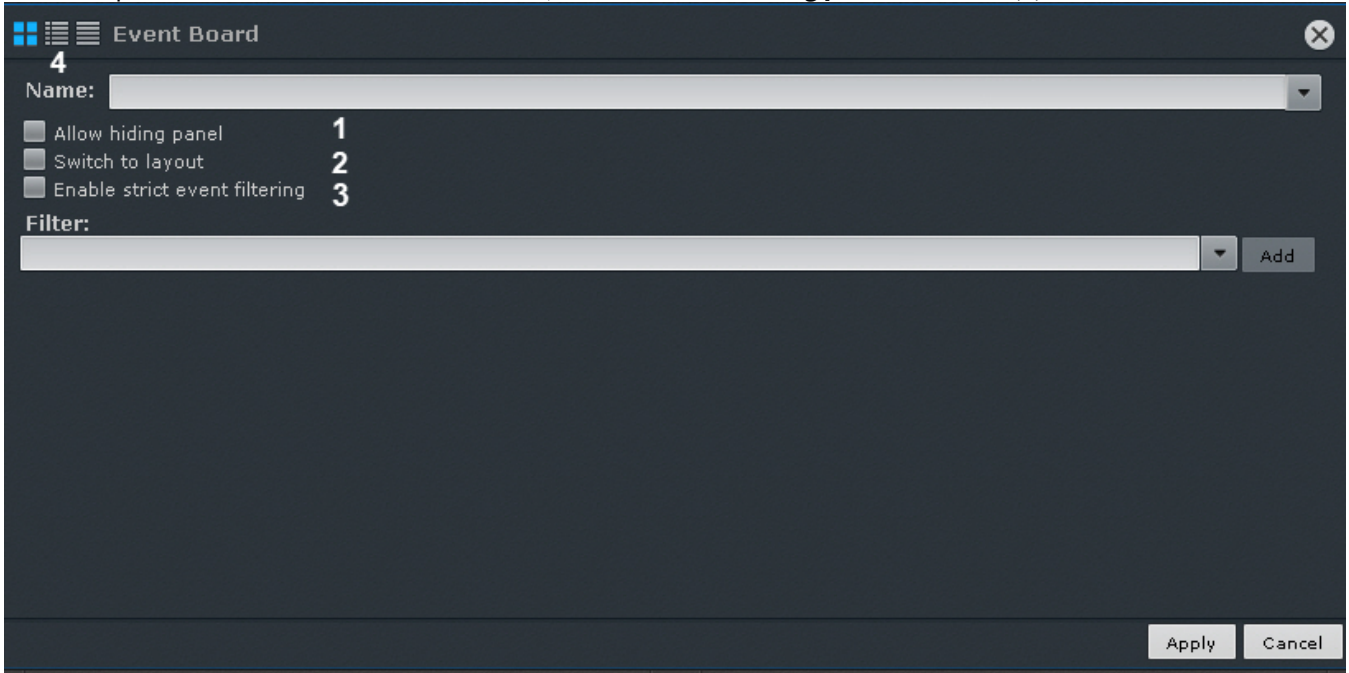

- To automatically open the layout with this information board when an event matching the filter occurs, select the **Switch to layout** check box (2) (see paragraph 5).
If other layouts contain information boards with the same parameters, the layout with the smallest number of cells is opened. If there are multiple layouts with identical numbers of cells, the layout that comes first in the alphabet is chosen. If a layout containing this information board is open when an event is received, no switch to another layout is performed.
- By default, some events on the Event board come with audit events. If no display of audit events is required, select the **Enables strict messages filtering** checkbox (3).
- In the list, select the event types that you want to display on the board and click **Add**.

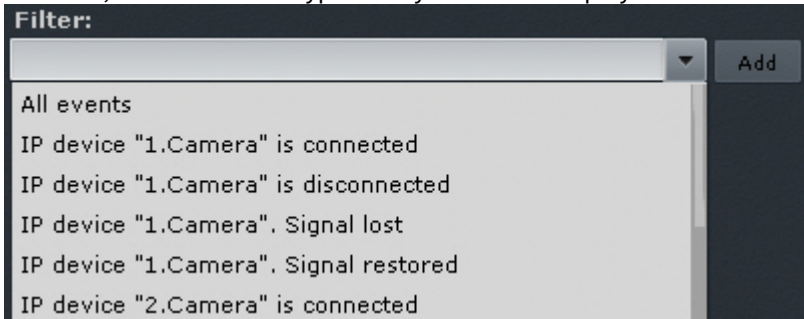

To add events of the same type from different devices, enter the name of the event in the **Filter** field. This will list only the events of the chosen type. To list all events, clear the filter field.

Note

To remove an added event type, click the  button

If no event type is selected, all system events are displayed on the information board.

Note

You can also add any text to the filter. For example, if you add **Signal lost** filter, Event Board will display event data from all devices in the system.

Note

To display facial detection tool triggering, we recommend you to select the **Triggered specified detection "Face appeared"**.

7. Select the default view for information on the Events Board (see [Options for displaying information on Events Boards](#)): the first frame of the event and time, first frame and text, or text only (4).
8. Click the **Apply** button to save changes (4).

Configuration of the Events Board is complete.

7.7.5.5.3 Configuring a Health Board

Switching to layout editing mode

Health Boards display the status of selected system servers and connected cameras.

To configure a Health Board:

1. Add an information board to the layout (see [Adding information boards to cells](#)).
2. In the upper-right corner, click the  button.
3. To allow operators to hide the information board, select the **Allow hiding panel** check box (1).



4. To automatically open the layout with this information board when the status of a monitored server or camera changes, select the **Move to layout** check box (2) (see paragraphs 5 and 6).
If other layouts contain information boards with the same parameters, the layout with the smallest number of cells is opened. If there are multiple layouts with identical numbers of cells, the layout that comes first in the alphabet is chosen. If a layout containing this information board is open when an event is received, no switch to another layout is performed.
5. Select the Servers you want to monitor. To do so, select one server or all servers from the Axon domain (click **All selected Servers**) and click the **Add** button (3).

Note

To remove the selected server, click the  button

6. To display the status of only distressed servers out of those selected, select **Only malfunctioning Servers** (3).
A server is classified as distressed if any of the following are true:

- a. Any component (CPU, hard disk, or network connection) is in critical condition.
- b. There is no connection to the Server.
- c. Any video cameras of the Server are in critical condition.

Note

Information about the status of Servers and cameras is given in the section [Working with Health Boards](#).

7. Select the default view for display of information on the Health Board (see [Working with Health Boards](#)): diagram, diagram with text, or table (4).
8. Click the **Apply** button to save changes (5).

Configuration of the Health Board is complete.

7.7.5.5.4 Configuring a Statistics Board

[Switching to layout editing mode](#)

Statistics Boards display information on the number of events of the selected type or types, as a number and graph.

To configure a Statistics Board:

1. Add an information board to the layout (see [Adding information boards to cells](#)).
2. In the upper-right corner, click the  button.
3. To allow operators to hide the information board from a layout, select the **Allow hiding panel** check box (1).

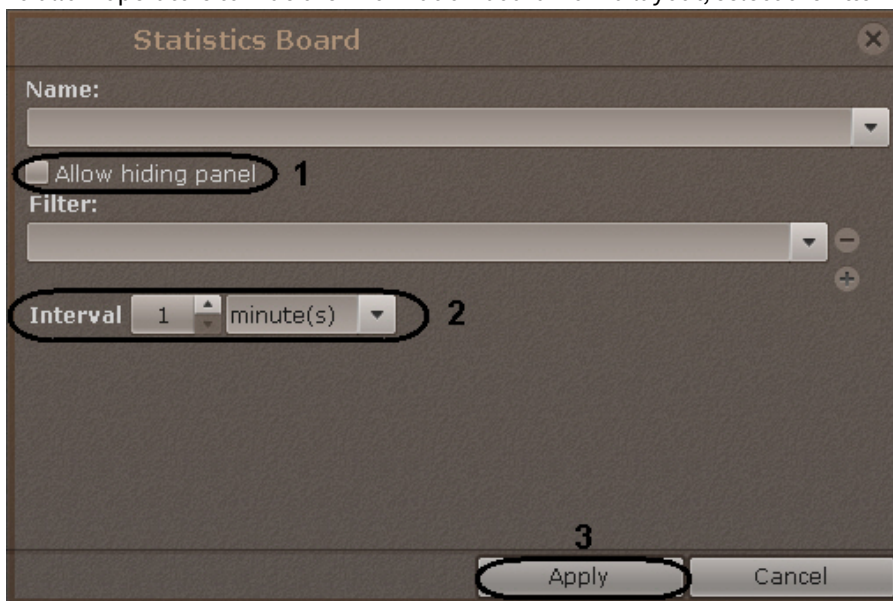

4. Select the event types that you want to be counted and click **Add**.

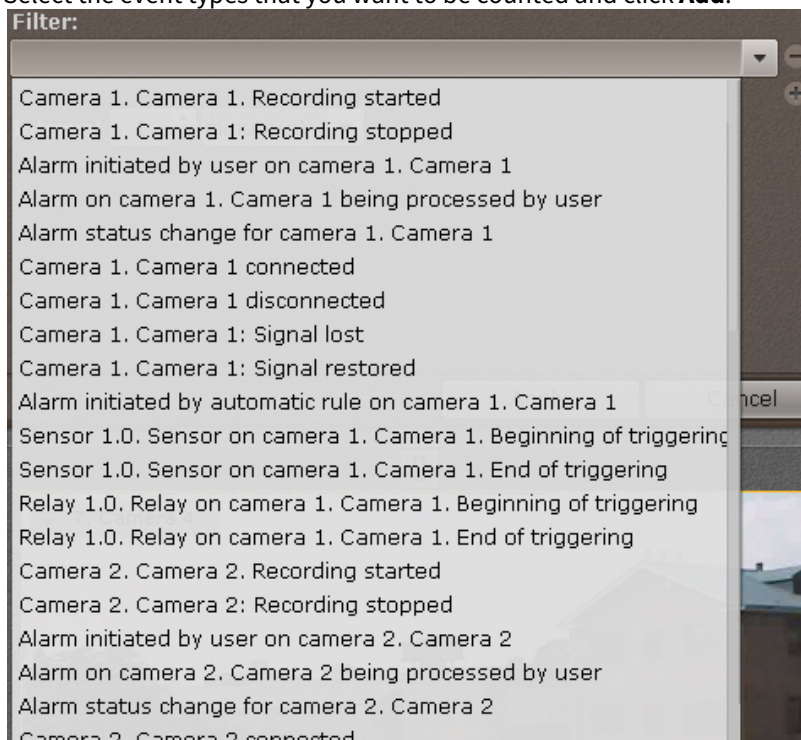

To add events of the same type from different devices, enter the name of the event in the **Filter** field. This will list only the events of the chosen type. To list all events, clear the filter field.

Note

To remove an added event type, click the  button.

If no event type is selected, all system events are counted.

5. Select the time period for display of statistics on the graph (2).
6. Click **Apply** to save the changes (3).

Configuration of the Statistics Board is complete.

7.7.5.5.5 Configure the Web Board

Switching to layout editing mode

Web Board allows users to view a selected web page in the tile.

Note

Axxon NextVMS shows web pages in Internet Explorer.

To configure **Web Board**:

1. Add an information board to the layout (see [Adding information boards to cells](#)).
2. In the upper-right corner, click the  button.

3. To allow operators to hide the information board, select the **Allow hiding panel** check box (1).

4. Enter the address in the **URL** field (2).

Note

The **URL** field supports addresses in the following formats:

- http://www.site.com
- http://site.com
- https://www.site.com
- https://site.com
- www.site.com
- site.com
- [IP-address]
- [IP-address]:[Port]
- http://[IP-address]
- http://[IP-address]:[Port]

5. Click the **Apply** button to save changes (4).

Configuration of the **Web Board** is complete.

7.7.5.5.6 Configure the Dialog Board

[Switching to layout editing mode](#)

Dialog Board allows users to view info about alerts / detection events and quickly start macros to respond.

In addition, the panel can display:

- video from the selected camera on the layout;
- video from the Related camera for the selected camera on the layout;
- video from the Related camera for the camera linked to the panel;
- alarm event from the selected or linked camera;
- still image.

You can configure Dialog Board as follows:

1. Add an information board to the layout (see [Adding information boards to cells](#)).
2. In the upper-right corner, click the  button.
3. To allow operators to hide the information board, select the **Allow hiding panel** check box (1).

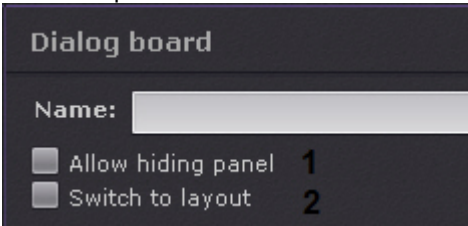

4. Select the **Switch to layout** check box (2) (see paragraph 5) to automatically open the layout with this information board when an event matching the filter occurs.
 If other layouts contain information boards with the same parameters, the layout with the smallest number of cells is opened. If there are multiple layouts with identical numbers of cells, the layout that comes first in the alphabet is chosen. If a layout containing this information board is open when an event is received, no switch to another layout is performed.
5. Select the event types that you want to display on the board and click **Add**.

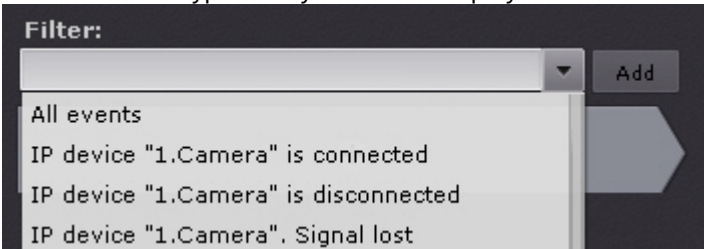

To add events of the same type from different devices, enter the name of the event in the **Filter** field. This will list only the events of the chosen type. To list all events, clear the filter field.

Note

To remove an added event type, click the  button.

Note

If the board has video, the event filter is not required.

If no event type is selected, all system events are displayed on the information board.

6. Configure the information board:
 - a. If you want video on the board, then click the  button and select the item in the menu. You cannot add other elements if you have video here.
 - i. **Video** – if you want to display video from the selected camera (1).

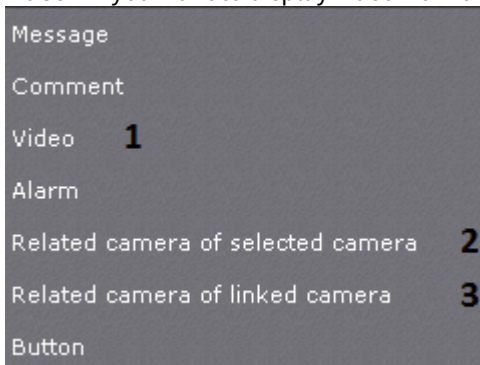

- ii. **Related camera of selected camera** - if you want to display video from the related (alternative, see [The Video Camera Object](#)) camera of the selected camera (2).
 - iii. **Related camera of linked camera** - if you want to display video from the related (alternative, see [The Video Camera Object](#)) camera of the linked camera (3). In this case, the panel must be connected to some camera window.
- b. If you want to display a still image on the panel, select the "Image" element. To do this, select a desired image in JPEG, PNG or BMP format (1) and, if necessary, adjust it to panel size (2).

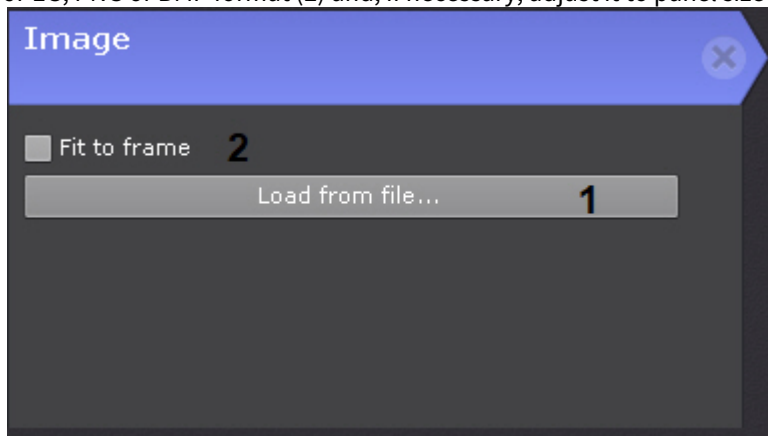

- c. If you want to display an alarm event in the panel from the selected or linked camera, select **Alarm**. If the panel is linked to any camera window, then alarms from this camera will be displayed. If the panel is not linked to any tile, then alarms from any selected camera will be displayed.

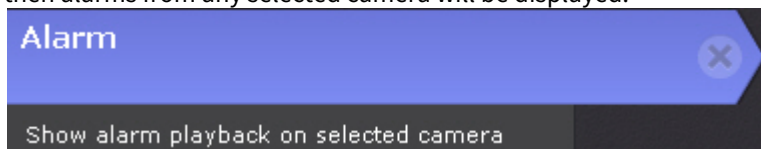

When you add the **Alarm** item to the message panel, you can also add pre-programmed buttons to evaluate the alarm event (see item **e** below). It is color-coded as follows:

- Green - **False alarm**
- Yellow - **Non-critical alarm**
- Red - **Critical alarm**



- d. If necessary, add a message that will be displayed on the panel in case of event (4). You can select the font and color (3) of the message. If it is necessary to display the event text, set the **Show last event** checkbox (1). To keep

all events on the panel and be able to navigate between them, set the **Keep events log** checkbox (2).

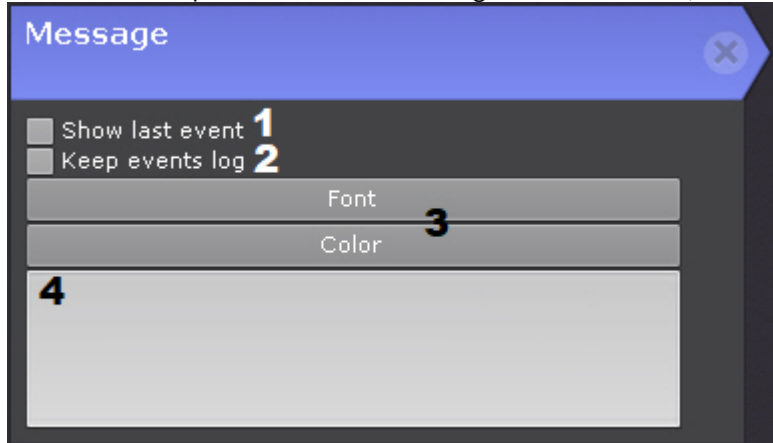

e. If necessary, add the comments field. Select the appropriate check box to make comments mandatory.

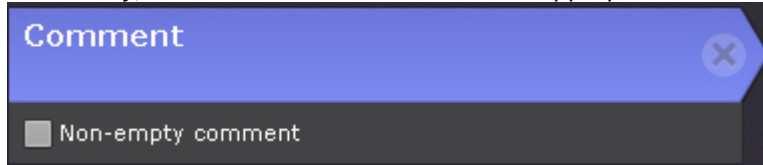

f. Add one or more Response Buttons.

To configure Response Buttons, you should set the mandatory and optional parameters (by clicking ):

- Enter the name of the button (1).

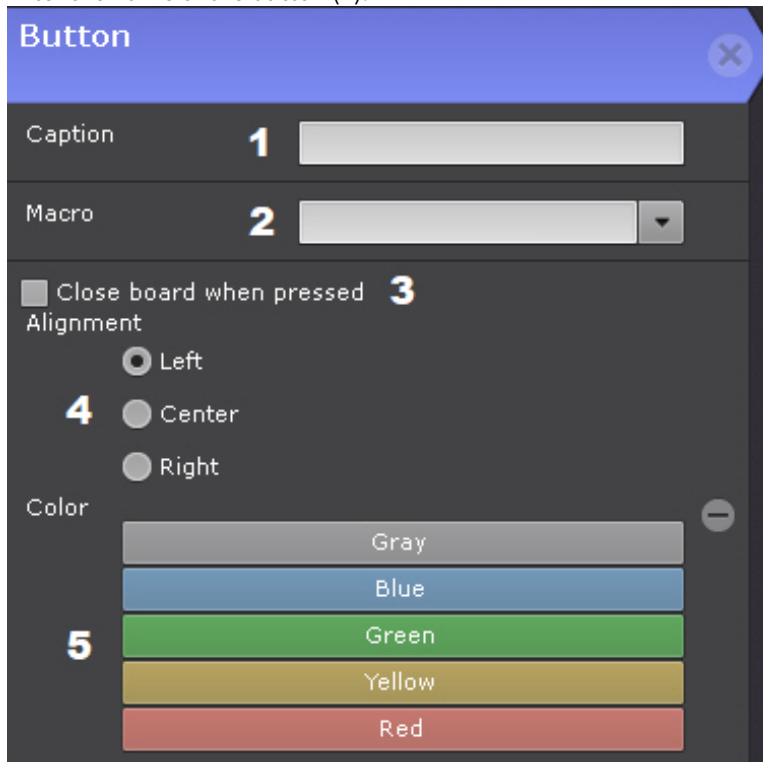

- Select a macro that will start when you click the button (2).
- If you want to hide the board after pressing the response button, select the checkbox (3).
- Select location for the button: On the left, in the center, on the right (4).
- Select a color (5).

7. Click **Apply** to save the changes

Configuration of the Dialog Board is complete.

7.7.5.6 Configuring Alarms Panel on a layout

You can configure the size of Alarms Panel (see [Alarms Panel](#)) with included videos for each layout separately.

To do it, follow the steps below:

1. Go to the desired layout.
2. Open the Alarms Panel and set desired sizes of videos, and of the panel itself (see [Alarms Panel](#)).
3. Switch to the Layout Editing mode (see [Switching to layout editing mode](#)).
4. Exit the Layout Editing mode and save changes (see [Exiting layout editing mode](#)).

The Alarms Panel will always open as you have specified it for this layout.

7.7.5.7 Exiting layout editing mode

To exit layout editing mode and save changes, click **Save** in the upper panel.



To exit editing mode without saving changes, click **Cancel**.

7.7.6 Share Layouts

You can share custom layouts with other users. The user can share only his/her custom layouts.

Note

This feature comes in handy, when it is only the administrator's job to create and edit layouts. After configuring, the administrator can assign the layouts to users/roles.

To share a layout, complete the following steps:

1. Select a layout (see [Selecting a layout for editing](#)) and go to Layout Editing mode (see [Switching to layout editing mode](#)).
2. Click the  button and open the context menu. Select one or several roles in **Share layout**.

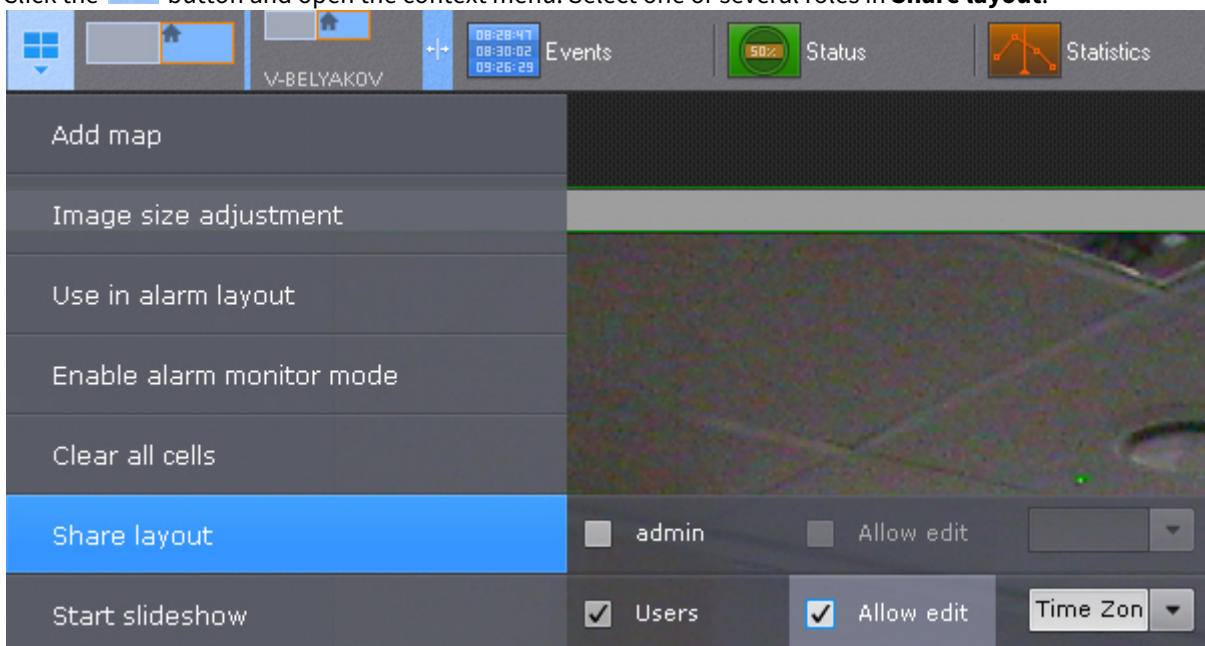

Note

You can select the roles of the selected Axxon domain. Axxon domain can be selected on the [Camera Search Panel](#).

3. If you want to grant rights to edit layouts, select the **Allow edit** checkbox for the required user role.
4. If you want to make the layout accessible only within a pre-defined time window, select the corresponding Time Zone from the list.
5. Exit layout editing mode (see [Exiting layout editing mode](#)).

This layout is shared with other users.

These users can not edit and share this layout. They can:

1. Work with layout (see [The Layouts panel](#)).
2. Delete it from their list (see [Creating and deleting layouts](#)).

Note

Only the layout owner can completely remove it from the VMS.

Upon removal, the layout becomes unavailable to all users. If the removed layout was open on some user's monitor, it is immediately replaced by another layout.

3. Copy the layout (see [Layout copying](#)). If you copy the layout, you are the owner of your copy. You can edit it.

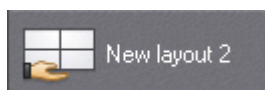

Shared layouts are sealed with the following sign:



7.7.7 Configuring special layouts

7.7.7.1 Creating special layouts

There are three special layouts available in the *Axxon Next*:

1. A layout that displays all the cameras with active alarms .
2. A layout that displays all selected video cameras .
3. A Dynamic Layout that displays the cameras added from Object Panel in Live Video mode .

To create a special layout, do as follows:

1. Click  to open the context menu of the Layout ribbon.
2. Select the temporary layout you want.

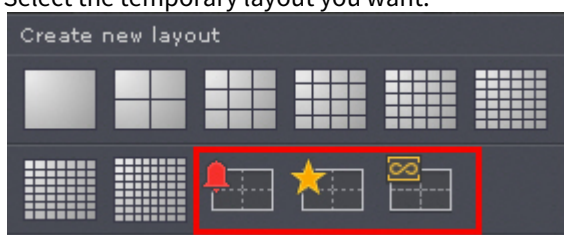

The layout has now been created and added to the panel.

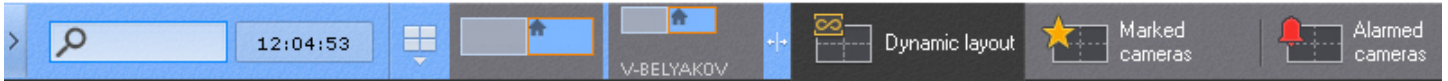

You can manage the number of cameras on special layouts with the layout format - 1, 4, 9, 16, 25, 64 (select in the menu). Dynamic Layout is created empty.

Note

By default, the Selected Cameras layout is 3 * 3, and the Alerted Cameras layout changes automatically depending on the number of alarms.

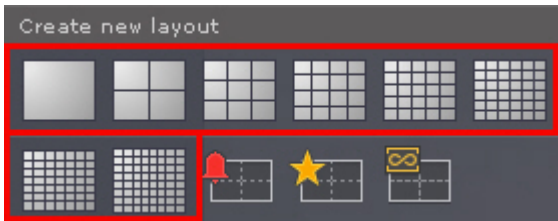

Note

To return to automatic change of the Alerted Cameras layout, click the format that you selected again.

Also, you can change any standard layout to an alerted one. To do this, in the layout editing mode, open the menu and select **Enable alarm monitor mode**.

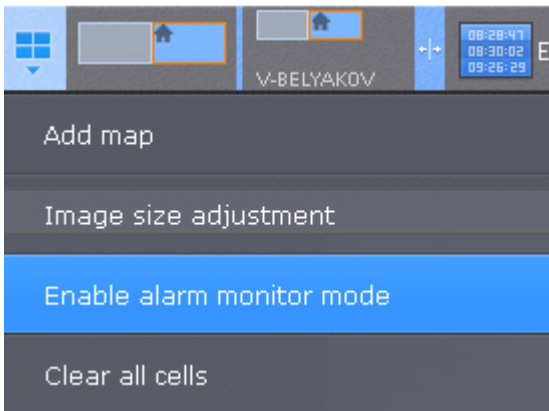

In this mode, if no active alarms are present across the cameras of the current layout, all camera windows are displayed. If any active alarms are present, only alarm camera windows are displayed.



In alarm monitor mode, the layout will be marked with

7.7.7.2 Configuring Alerted Cameras layouts

By default, special layout display alerts from all cameras. You can limit this: alerts only from the selected layouts.

To do this:

1. Select the layout (see [Selecting a layout for editing](#)).

- Open the context menu and select: **Include to alarm layout**.

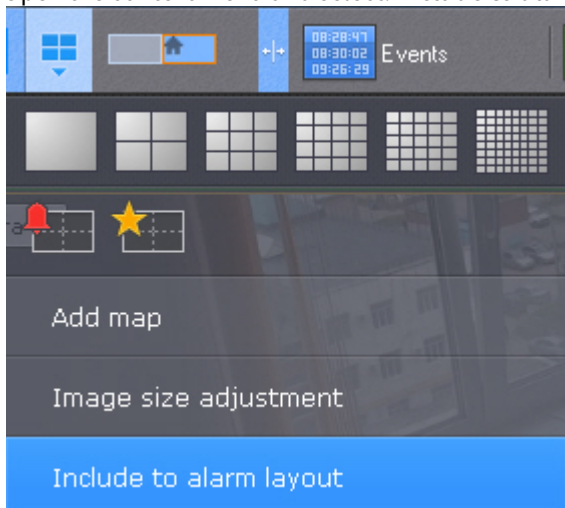

- Save changes (see [Exiting layout editing mode](#)).

Note

To undo, select: **Exclude from alarm layout**.

Also, you can customize the layout with active alarms to show:

- An alarm and the Alarm Management option (**1**). If there are several alarms, the longest-standing alarm is displayed. If you classify an alarm, the next alarm is displayed.

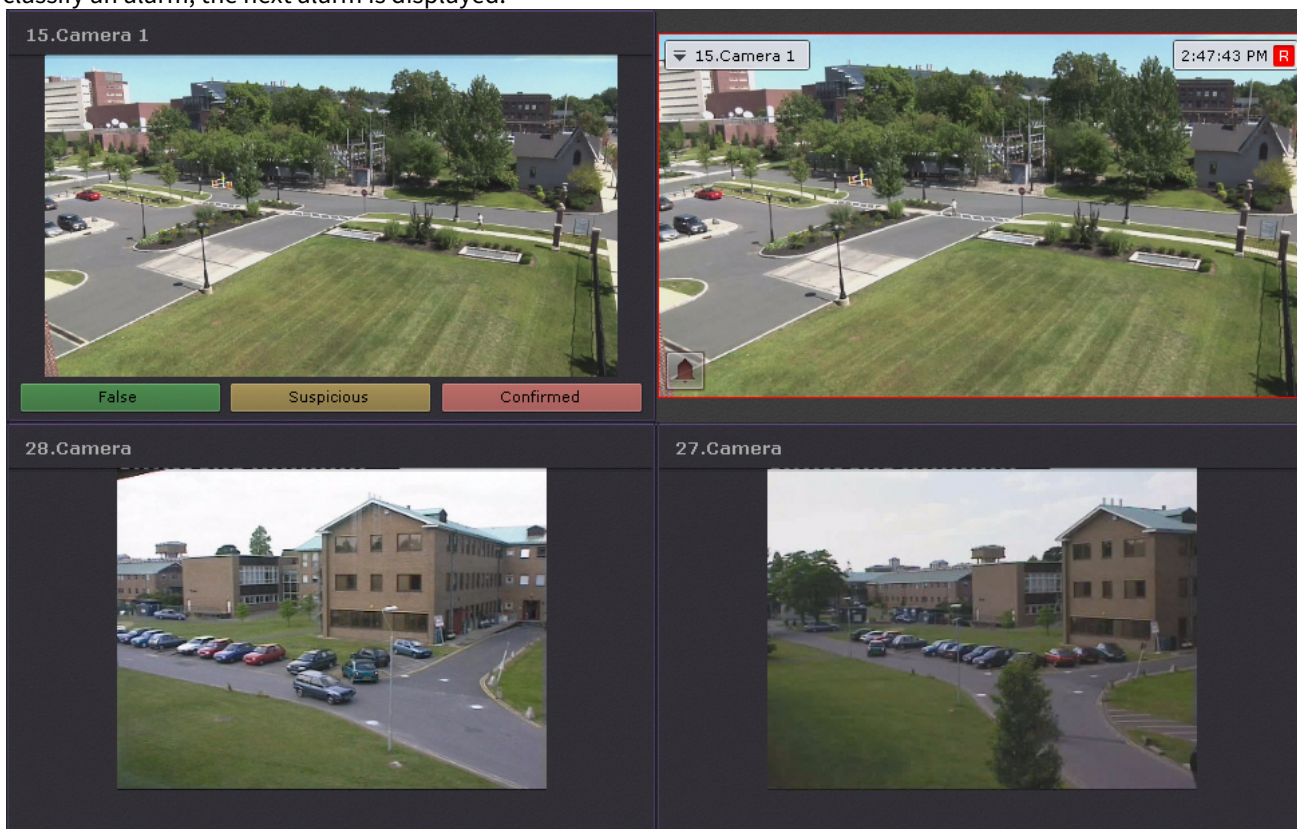

- An alerted camera in Live Video mode (**2**).
- 2 additional cameras (**3, 4**) in Live Video mode (for example, the 2 nearest ones to the alarmed one).

Do the following:

- Switch to the Layout Editing mode (see [Switching to layout editing mode](#)).

- In the first cell, add a Dialog board (see [Configure the Dialog Board](#)) with the **Alarm** element and 3 buttons (green, yellow and red) without specifying a macro (1).

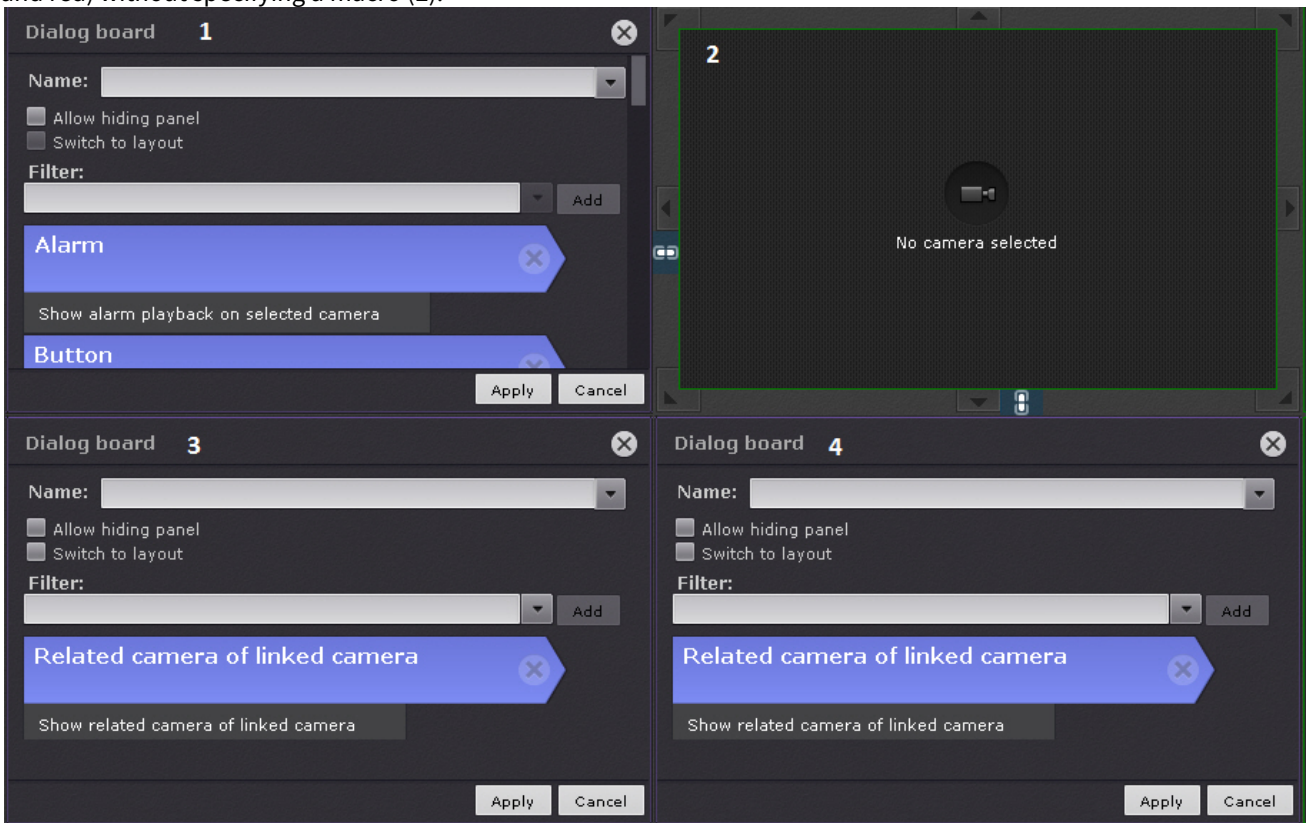

- Leave the second cell empty (2).
- In the third and fourth cells, add a message panel with **Related camera of linked camera** (3, 4).
- Link cells as follows: 1 with 2, 2 with 4, 3 with 4 (see [Linking cells](#)).
- Save the layout.
- For each camera, select 2 stand-by cameras (for example, those closest to it, see [The Video Camera Object](#)).

Note

In cell 4, the first stand-by camera will be displayed, in cell 3 - the second.

7.7.7.3 Configuring Selected Cameras layout

To add a tag to a video camera, do one of the following actions:

- Click the star  in the top left corner of the camera window;



- Click the star in Camera Search Panel (see [Camera Search Panel](#));

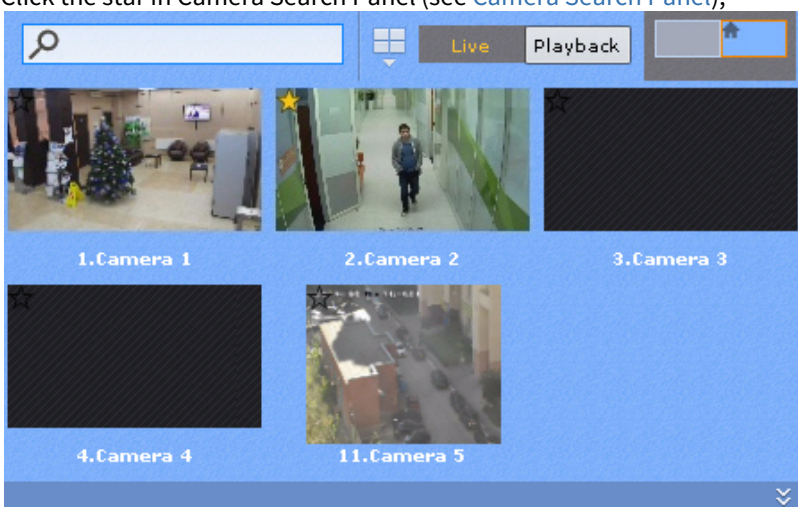

- Click the star in Object Panel (see [Objects Panel](#));

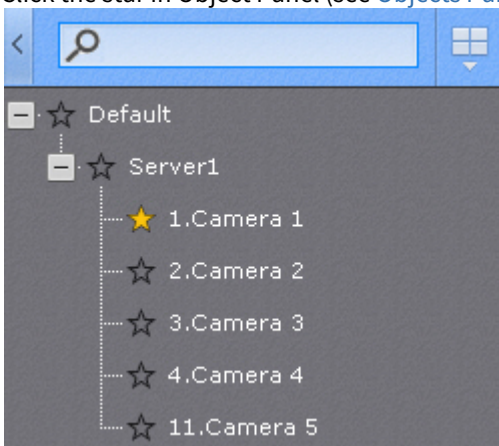

Attention!

You can add tags to cameras on any video wall (see [Managing monitors on a local Client](#))

If you exceed the maximum number of cameras allowed, only the cameras most recently selected remain on the layout.

Note

To remove the tag, click the star again .

You can move cameras around on layouts by drag-and-drop.

Attention!

Camera windows are not saved on the layout. After restarting the client or server, you should add them again.

Note

You can use [Duplicate layout](#) to create a copy of the current special layout.

7.7.8 Configuring user-defined slide shows

A slide show is a set of layouts displayed on the operator's screen in a specified order for a specified dwelling time (see [Configuring Slideshow parameters](#)).

By default, the system includes only one slide show that includes all available layouts.

To create a user-defined slide show, do the following:

1. Go to Manage Layouts mode (see [Creating and deleting layouts](#)).

2. Click  and select **Create slideshow**.

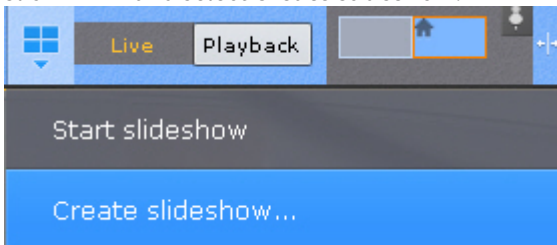

3. Select layouts to include into the slide show.

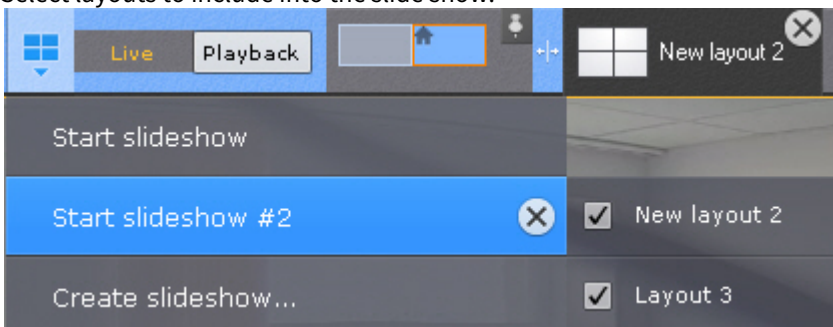

4. Click **Save**.

To remove a user-defined slide show, click the  button.

7.7.9 Setting the default layout

You can set a default layout to be displayed after you launch the Web Client.

To set the default layout, do the following:

1. Go to Manage Layouts mode (see [Creating and deleting layouts](#)).
2. Go to the desired layout.

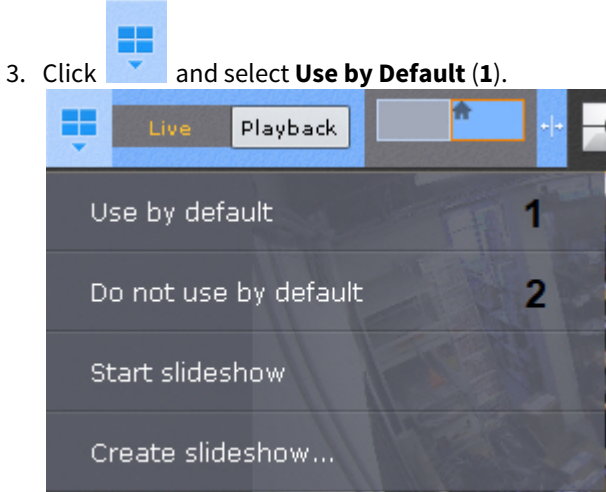

Now, the current layout is assigned as default.



To assign another layout as default, repeat the steps above.

To make the system operate without a default layout, click  and select **Do not use by default (2)**.

7.7.10 Setting a layout ID

You can set an ID for a layout. This may appear useful for calling layouts with hotkeys (see [Notes regarding hot key actions](#)).

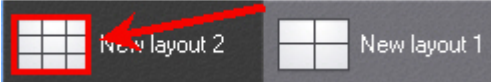
To specify an ID, do the following:

1. Double click on a layout thumbnail.
 
2. Enter an ID.
 
3. Click anywhere in the Client UI.

Now, the ID is added and displayed before the layout name.

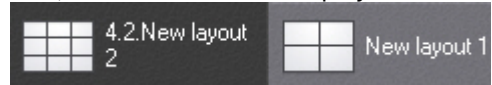

Note

When you hover the mouse cursor over a layout, the name and ID (if specified) of the layout are displayed separately.

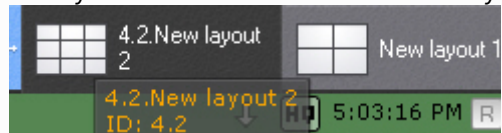

7.8 Configuring Video Wall



A Video Wall is a set of display monitors physically and logically connected to act as a single screen.

A video wall may include any monitor connected to any Client within the Axxon domain.

You can set up a video wall via a dedicated panel (see [Video Wall Panel](#)).



To set up a video wall, do the following:

1. Click the  button.
2. Click the  button. The list of available Clients pops up. Left click a Client to display its active monitors.

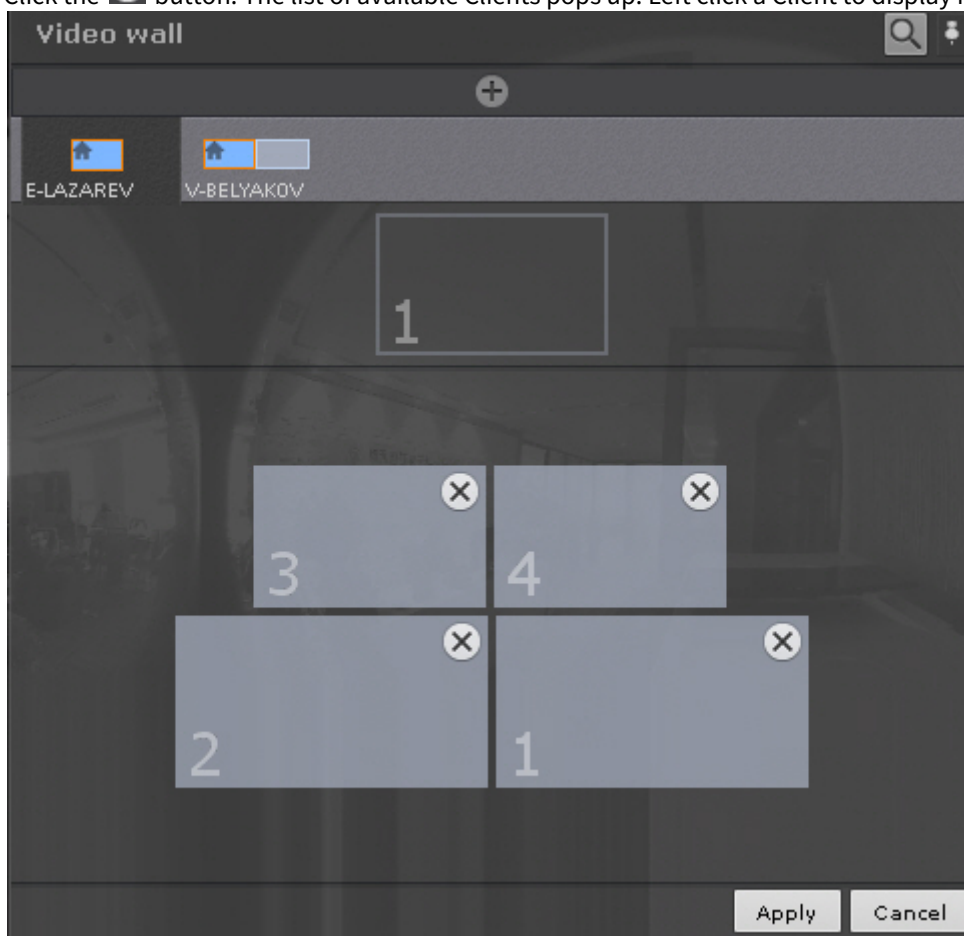

3. Drag and drop monitor icons according to their monitors' physical locations on the video wall.



Note

An ID number is assigned to each monitor added to a video wall. To display the ID number of a monitor, click .

4. Click **Apply**.

Now, the video wall is configured.

Note

You can manage video wall's monitors the same way as Client monitors (see [Managing monitors on a local Client](#), [Managing monitors on remote Clients within the Axxon domain](#)).

7.9 Configuring the Interactive Map

Configuration of the interactive map is performed in layout editing mode (see the sections [Interactive Map](#), [Switching to layout editing mode](#)).

Note

Creation, editing, and deletion of interactive maps are available to users with roles for which the **Change maps** component is activated (see the section [Configuring user permissions](#)).

7.9.1 Creating a new map

To create a new map, complete the following steps:

1. Do one of the following four actions:

- a. In the lower-left part of the screen, click the  button (after displaying the map, see [Opening and closing the map](#)).

- b. Click the  button to open the context menu of the layouts ribbon and select **Add map**.

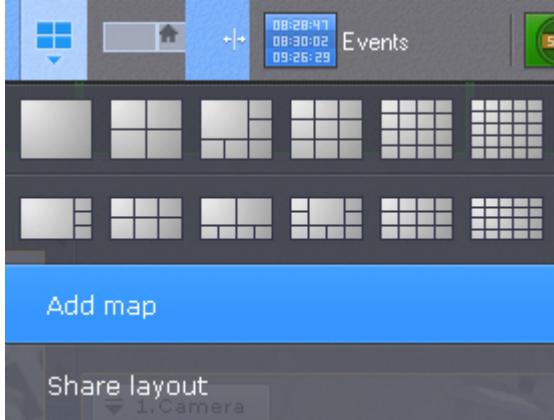

- c. In the map context menu (right-click the empty background), select **Add new map**
- d. Select a video camera from the list on the video camera panel by clicking it and, while holding down the mouse button, move the cursor to the empty map background and then release the mouse button.



Note

Actions **c** and **d** are available if no maps have been created in the system

2. Enter the map's name (**1**).



3. Select what will be used as a map: an image or geodata from OpenStreetMap (**2**).

Attention!

Creation of a map based on OpenStreetMap geodata provider is limited by default. To create OpenStreetMap maps, you should:

1. Purchase an [OpenStreetMap license](#).
2. Quit Client (see [Shutting down an Axxon Next Client](#)).
3. Open a configuration file, *AxxonNext.exe.config*, in a word processor. The file is located in the <Installation Directory of Axxon Next> \ bin.
4. Find the OpenStreetMap parameters group.

```

</provider>
<provider name="openStreetMap">
  <param name="Id" value="32AAE9D2-CB9D-4B45-8888-CE180629600D"/>
  <param name="Copyright" value="© MapBox, © OpenStreetMap"/>
  <param name="MinZoom" value="3"/>
  <param name="MaxZoom" value="17"/>
  <param name="DefaultZoom" value="9"/>
  <param name="Enabled" value="true"/>
  <param name="ApiKey" value="pk.eyJ1Ijoicm9tYW5rYWgfdmIiwiySI6ImNpcjF5b3RyYzNjAwN3podm5uc2ZuaxVTC
DMifQ.bUKBmLRZtCzkqy0wSwvsZg"/>
</provider>
</mapProviders>

```

5. Set the **true** for the **Enabled** parameter.
6. For the **ApiKey** parameter, enter the received key.
7. Save the changes to the file.
8. Run the Client (see [Starting an Axxon Next Client](#)).

Note

The maximum image size is 4 million pixels (the number of pixels at 2000x2000 resolution). If a larger image is selected, no map is created

4. In the corresponding field **(3)**, select the image that will be used as the graphical blueprint of the site (if the **Raster image** map type is selected, supported formats: png, jpg, jpeg, jpe, gif and bmp) or find the site in OpenStreetMap by address, postal code, or geographical coordinates (enter the information in the **Address** field; detailed information about search is given on the [provider's website](#)). Scale can be adjusted by the scaler control or mouse wheel. You can navigate around the map using standard methods.

Note

If the **Raster image** map type is selected, it is not necessary to select an image. In this case, a map with a white background is created.

5. If you use geo maps, enter the address, postal index or OpenStreetMap coordinates (refer to [provider's website](#) for details) of the desired location into the **Address** field, then click . Use the slider or the mouse scroll wheel to zoom in and

out, and any standard method for map navigation.

New Map

Name
Safe city

Type
OpenStreetMap

Address
London

6. Select users to access the Map (4):
 - all users,
 - current user only (**Not shared** position)
 - selected roles only (5).
7. Click **Apply**.

You have created a new map.

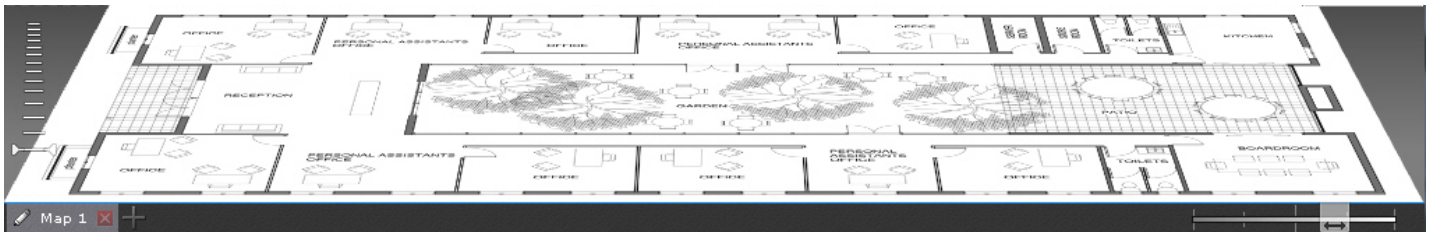

7.9.2 Adding system objects to the map

On maps you can add three types of system objects (video camera, input, and output) as well as objects for switching to another map.

7.9.2.1 Adding video cameras

You can add cameras to the map in one of three ways:

1. By using the viewing tile context menu.
2. By using the map context menu.
3. By dragging a video camera icon from the video camera panel to the map.

To add a camera to the map, in the context menu of the viewing tile, select **Add to map**.

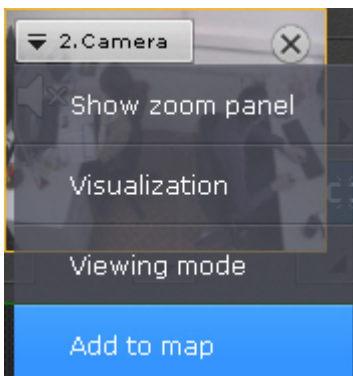

The camera is added to the map.

Attention!

When a camera is added to a geo map, its icon is automatically positioned according to the camera coordinates (see [The Video Camera Object](#)).

If the cameras have a built-in GPS tracker, their locations on the map change automatically according to the received data (see [Configuring cameras with a built-in GPS tracker](#)).

To add a video camera by using the map context menu:

1. Right-click to open the map context menu and select **Add video camera**.

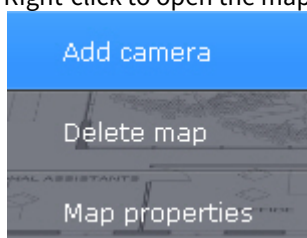

2. Select the necessary video camera in the displayed list by using one of the following methods:
 1. If the necessary video camera is included in a group, you must first select the group (the group may also contain subgroups), then select the video camera.
 2. If the necessary video camera is not included in one of the groups, you must select the list of all video cameras that follows the list of groups.

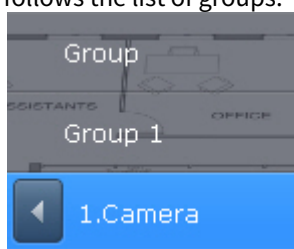

The camera is added to the map.

You can also, in the video camera panel, left-click a video camera's icon. Drag it to the map.

If you use this method to transfer a group of cameras to the Map, all cameras within the group will be added.

7.9.2.2 Adding inputs and outputs

To add Inputs and Outputs of video camera to the map:

Note

Only **Input** and **Output** objects that have been activated can be added to the map.

1. Right-click the icon of the video camera on the map. A context menu appears.
2. To add a Input, select **Add Input (1)**. To add a Output, select **Add Output (2)**.

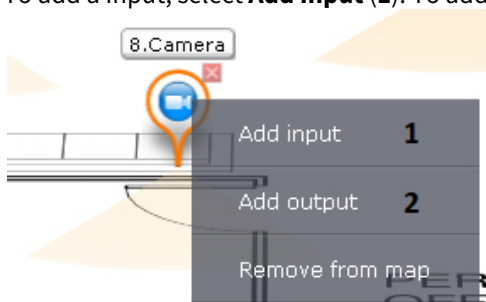

3. In the list, select a **Input** or **Output** object.



Inputs and Outputs have now been added.

By default, the icons of the Input and Output are attached to the video camera's icon. If you move the video camera icon, the icons of all of the video camera's devices are moved as well.

However, you can detach the Input and Output icons from the icon of the video camera. To do so, move them. Then the Input and Output icons are moved independently.

To add Inputs and Outputs of I/O devices to the Map, do the following:

1. Right-click anywhere on the map for a context menu.
2. Select **Add input** or **Add output**.
3. In the list, select a **Input** or **Output** object.

7.9.2.3 Adding switches to another map

You can add a "switch" to another map in one of two ways:

1. Select the tab of the map to which you want the switch to point and, without releasing the mouse button, drag it to the map and release the mouse button.
 2. By using the map context menu.
1. Select **Add transition to map**.

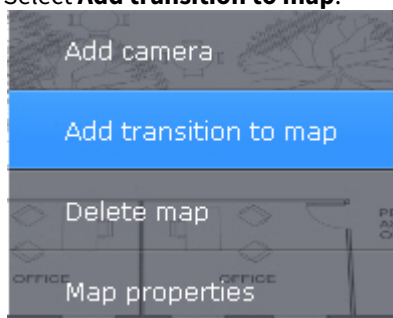

2. Select the map in the system to which the new switch will point.



Addition of the switch is now complete



Then drag the switch icon to the necessary place on the map.

7.9.3 Configuring cameras on the map

7.9.3.1 Configuring a camera in standard map viewing mode

After adding a camera to the map, perform the following actions:

1. Drag the video camera's icon to the place on the map that represents the camera's actual location at the site (**1**).

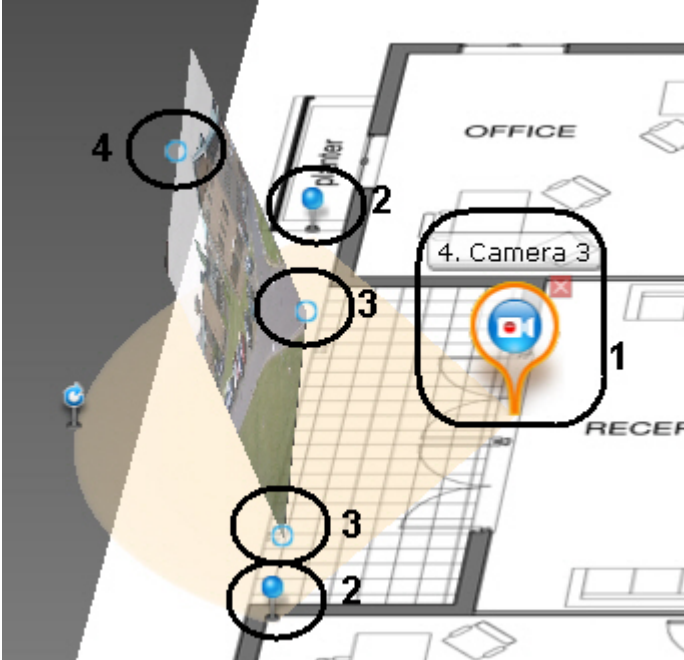

2. On the map, use the corner nodes to adjust the video camera's field of view to match the actual situation at the site (**2**).

Important!

For ceiling-mounted fisheye cameras (see [Configuring fisheye cameras](#)), you are advised to set a 360° field of view. If you do so, the video from the camera will be directly available in the specified area:



To enable this feature on cameras with ImmerVision lenses, **PTZ** display mode must be chosen (see [Configuring fisheye cameras](#))

3. Configure the area for video display:

Important!

The video display area is not available for ceiling-mounted fisheye cameras

- using the points at the base (**3**), set the size of the area (left-click and drag the cursor)
- using a third point (**4**) to change the tilt of the area

Note

You can switch map display to flat while working with the Map (see [Customizing an Interactive Map](#)).

- using the slider in the lower-right corner to set the default transparency of the area



Configuration of the camera in standard map viewing mode is complete.

7.9.3.2 Configuring cameras in immersion mode

You can link video to the objects shown on a map. This allows making video surveillance more visual and informative.

The feature is available through immersion mode (see [Immersive mode](#)).

To link video to a map, use the four attachment points. Objects in the video need to be linked to their depiction on the site map.

To link objects with symbols on the map:

1. Click an object in the video. A point is added.

Important!

When specifying points on an image, follow the rules:

1. All 4 points should belong to the same horizontal plane. Place points on the floor or on the ground.
2. Do not place 3 points on one line.
3. Points should show the perspective of the plane.

2. Click on the depiction of the object on the map. A second point is added, connected by a line to the first point.

Important!

When a fourth link is made, it is possible that the second point cannot be placed in some areas. This occurs when the system cannot find a valid angle for displaying the video and map for the given links. Most likely, the links have been set incorrectly.



After a fourth link is added, an angle is chosen so that the surveillance objects in the video and on the map coincide.

To remove a link, place the cursor above the first point in the link and click the  button. After all links are added, it is possible to change the location of previously set points by dragging them while holding the left mouse button.

To save links between video and the map, exit layout editing mode and save changes. The links you make are discarded if any of the following occur before you exit and save changes:

- The position of the video camera icon on the map is changed.
- The angle of display of the video display area for the camera on the map is changed.
- The field of view of the camera on the map is changed in any way.

7.9.3.3 Configuring cameras with a built-in GPS tracker

Some devices contain a built-in GPS tracker that transmits the current coordinates of the device to Axxon Next VMS.

Location of these devices / cameras and their feeds are automatically geotagged when displayed on a geo map.

Note

This feature is widely used when cameras are installed, for example, in ambulances or public transport.

To enable this feature, do as follows:

1. Create a built-in GPS tracker object for video cameras (see [Creating Detection Tools](#)).

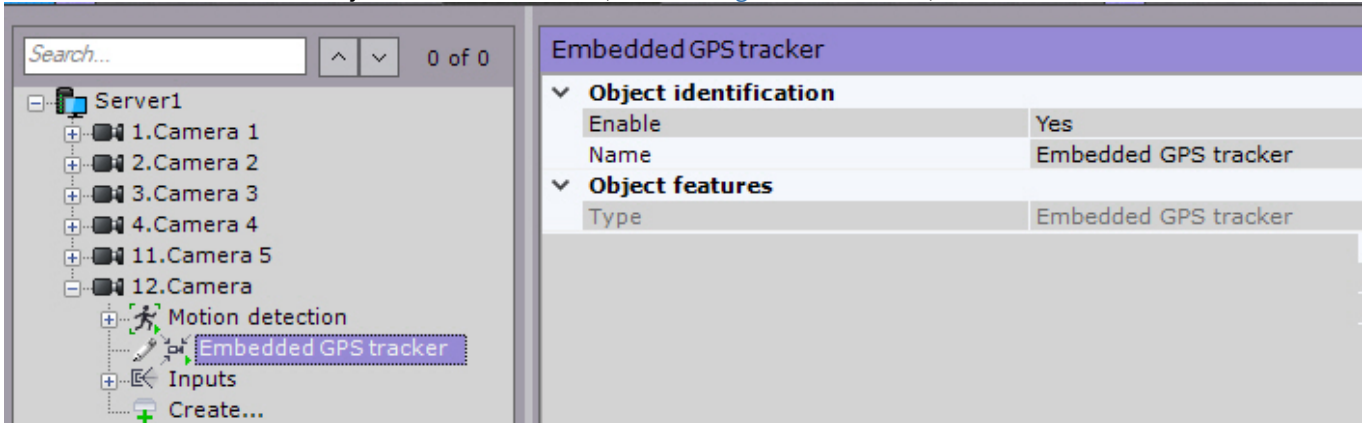

2. Create a geomap (see [Creating a new map](#)).
3. Add video cameras to the geomap (see [Adding video cameras](#)).

7.9.4 Attaching a map to a layout

You can attach a map to a layout. This means that when you switch to the layout, the attached map opens automatically.

To attach a map to a layout:

1. Select the layout with which you want to associate the map in the layouts ribbon or create a new layout (see [Creating and deleting layouts](#) and [Selecting a layout for editing](#)).
2. Go to map editing mode (see the section [Opening and closing the map](#))
3. Go to an existing map with which you want to associate the layout or create a new map (see the sections [Switching between maps](#) and [Creating a new map](#)).
4. Save changes and exit layout editing mode (see [Exiting layout editing mode](#)).

After you save the layout, its icon resembles that shown in picture below.

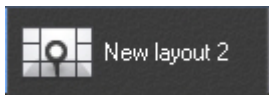

If a map is open in 2D mode when you save a layout, when you switch to that layout, the map will always open in 2D mode. The layout icon resembles that shown in picture below.



The map is now attached to the layout.

7.9.5 Removing objects from the map

To remove an object from the map, click the  button that is next to the object icon, or in the context menu, select **Remove from map**.

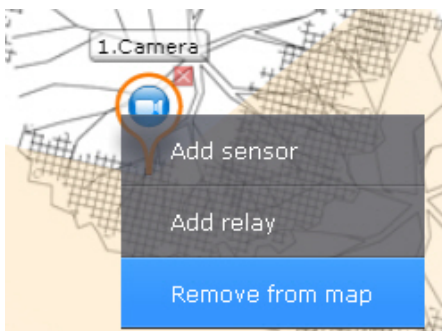

Note

To delete a map switch, you must click the  button.

7.9.6 Setting keywords for geo map search

The keywords are needed to locate a site or a street on OpenStreetMap.

For example, if you are searching for a site or a street in a particular city/town, the name of the town has to be entered as a keyword.

The default keyword is the address set during the map creation process (see [Creating a new map](#)).

To set new keywords, you need to:

1. Click  in the lower panel.
2. Enter the desired keywords.

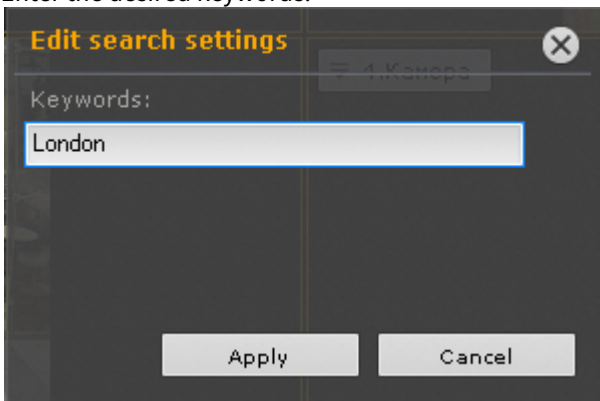

3. Click **Apply**.

7.9.7 Changing map type and display

You can change the type and display of a map that has been created previously. To do so, open the map context menu and select **Map properties**.

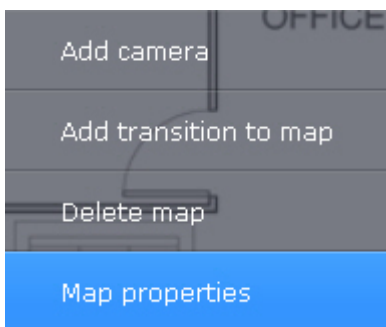

A map properties configuration window opens, which is similar to the map creation window (see [Creating a new map](#)).

7.9.8 Renaming the map

To rename the map, in the lower-left corner of the screen, left-click a tab and specify a new name.

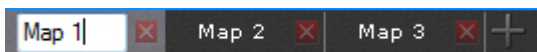

7.9.9 Sorting of map lists

You can change the order of tabs for previously created maps. By default, tabs with maps are ordered by creation date. To change the order, drag and drop tabs as necessary. Left-click a tab and drag it to the desired location.

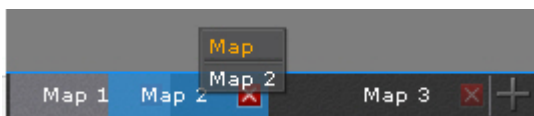

7.9.10 Deleting a map

To delete a map, in the lower-left corner of the screen, select the  button on the corresponding tab. Alternatively, in the context menu, you can select **Delete map**.

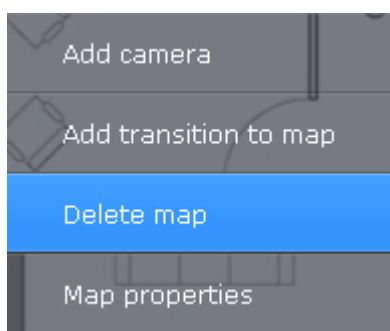

7.10 System preferences

7.10.1 Server settings

7.10.1.1 Configuring Forensic Search MomentQuest in Archive

On the page:

- [Turning on the video stream metadata recording](#)
- [Configuring user permissions for Forensic Search in archive](#)

To make it possible to perform Forensic Search MomentQuest of the archives of a video camera, the following conditions must be met:

1. Video meets the requirements (see [Video suitability for Forensic Search of recorded video \(requirements\)](#)).
2. There are video stream recordings from the desired video camera in the archive (see [Binding a camera to an archive](#)).
3. There are metadata recordings from this video stream in the object trajectory database. Metadata can be generated by Axxon Next (see [General information on Scene Analytics, Face detection tool](#)) or received from a video camera (see [Embedded Detection Tools](#)).
4. The user has the appropriate permissions.

This section contains information on how to configure the Axxon Next software package to satisfy these conditions.

7.10.1.1.1 Turning on the video stream metadata recording

To enable metadata recording, select **Yes** in the **Record Object Tracking** list for the corresponding detection tool (object tracker, facial recognition, base motion detection, onboard video analytics).

Note
The metadata recording is enabled by default.

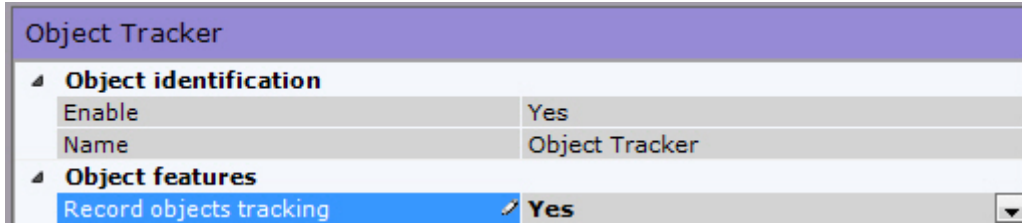

In video motion detection (VMD) settings, you have to activate the **Object Tracking** parameter (see [Setting up VMD-based Scene Analytics](#)).

Note
Information on configuring storage of metadata is provided in the section titled [Configuring storage of the archive, system log, and metadata](#)

7.10.1.1.2 Configuring user permissions for Forensic Search in archive

You need **Live/Archive**, **Live/Archive/Control** or **Live/Archive/Control/Configure** permissions for a video camera to perform a smart search (see [Configuring user permissions](#)).

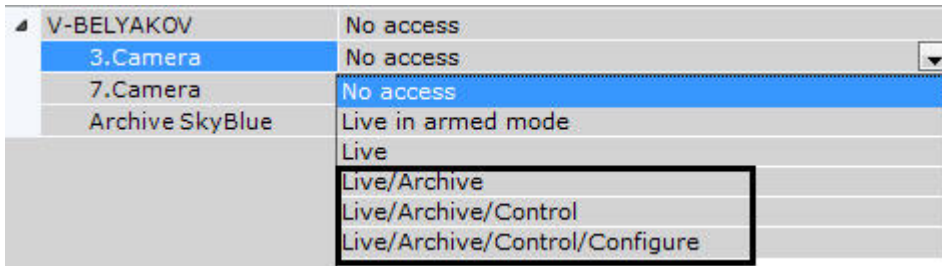

7.10.1.1.3 Video suitability for Forensic Search of recorded video (requirements)

For Forensic Search of recorded video to be possible, video must meet the same requirements as those applied to video for detection tools (see [Video requirements for scene analytics detection](#)).

In addition, the minimum and maximum detectable object speeds in video are related to the camera's frame rate.

1. The maximum detectable speed depends on the size of the object. The following table shows the relationship between the maximum detectable speed and the frame rate for typical objects (people and cars):

Frame rate	Maximum detectable speed for people	Maximum detectable speed for cars
6 fps	5 km/hr	40 km/hr
12 fps	10 km/hr	85 km/hr
25 fps	20 km/hr	170 km/hr

So if it is necessary, for example, to detect people moving at speeds of up to 10 km/hr, it is sufficient to record at 12 fps.

2. The minimum object speed should be such that the object moves at a rate of at least 1 pixel per frame.

7.10.1.2 Setting up privacy masking

7.10.1.2.1 Masking faces

You can mask recognized faces of a designated users' group (role).

The face(s) will be masked:

- during Live or Video Footage viewing,
- during Video Footage search.

Attention!

Privacy masks are displayed in the standalone Client software only. You cannot use masks with both web and mobile Clients.

To do it, follow the steps below:

1. Create and configure Face Detection Tools for cameras where face masking is necessary (see [Functions of facial detection](#)).
2. Set **No** for the **Show Faces** parameter in the Role Settings panel (see [Creating and configuring roles](#)).

As a result, faces will be masked on all designated cameras' videos for all users belonging to this role.



7.10.1.2.2 Setting up privacy masking in Video Footage

You can mask any objects from Video Footage viewing by any particular user.

The objects will be masked:

- during Video Footage viewing,
- during Video Footage search,
- on exported videos.

Attention!

Privacy masks are displayed in the standalone Client software only. You cannot use masks with both web and mobile Clients.

To do this, set **No** for the **Show Recorded Videos Unmasked** option in Role Settings (see [Creating and configuring roles](#)). The objects will be masked for all users belonging to this role.

To mask an object from Video Footage viewing, do the following:

1. Proceed to Archive Mode and find the object to be masked (see [Switching to Archive Mode](#)).
2. Locate the frame where the object first appears in the camera's FoV (see [Navigating in the Archive](#)).

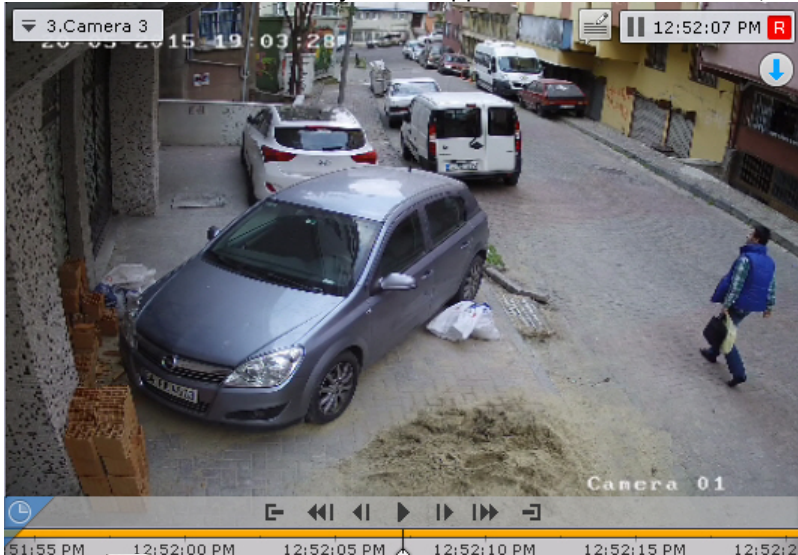

3. Click the  button.
4. Select a shape for the mask: oval or rectangular.

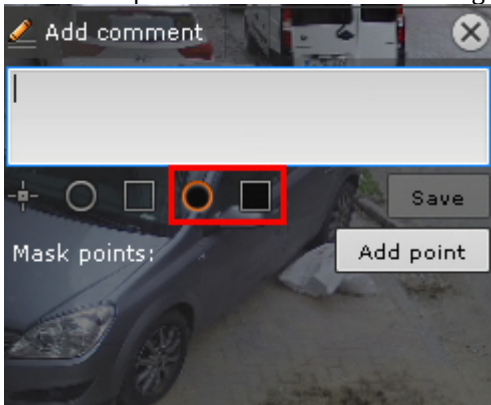

5. Apply the mask over the object.

Note

The procedure of setting up a mask is similar to adding a comment (see [Adding a comment](#))

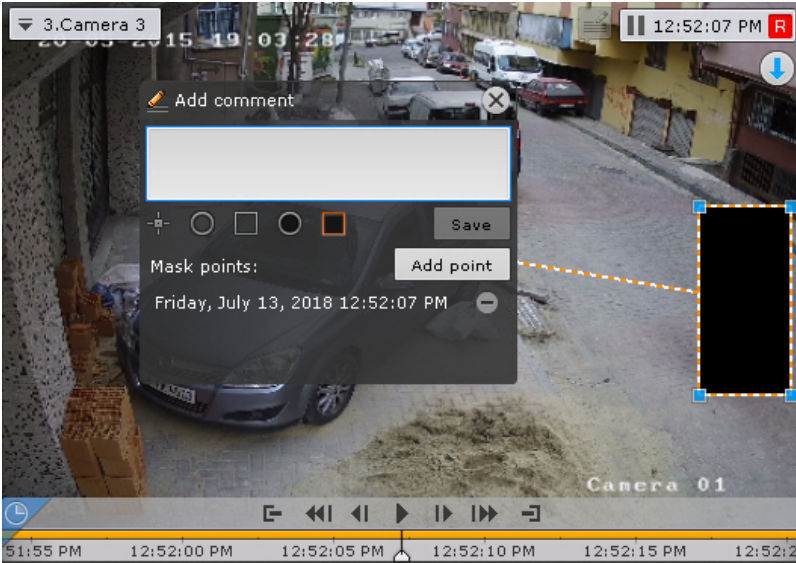

6. Locate the last frame before the object disappears from the camera's FoV and place the mask over it. To save mask position, click the **Add point** button.

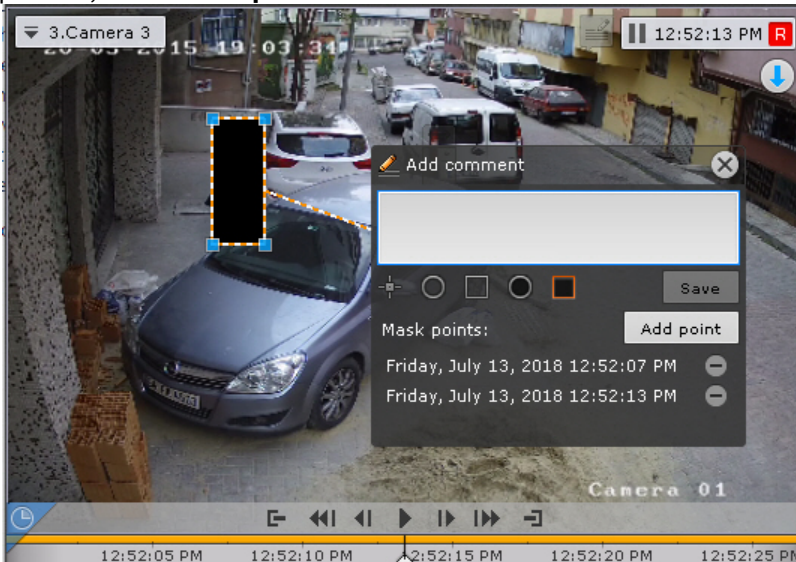

7. The system automatically interpolates the mask position on intermediate frames, assuming the object's motion is uniform and rectilinear.
8. Check the video. If necessary, you can specify additional mask positions on intermediate frames for better masking. The system automatically re-interpolates mask positions within the video sequence.

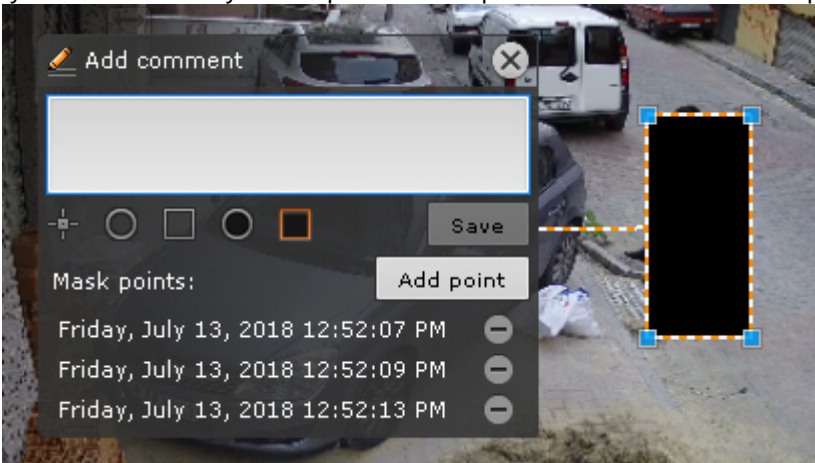

Note

To remove a mask position, click the  button.

9. After setting all necessary mask positions, enter your text notes and click **Save**.

Attention!

After the mask is saved, you can not delete it. Only the users having roles where **View masked video in archive** parameter is set to **Yes** may bypass the masking (see [Creating and configuring roles](#)).

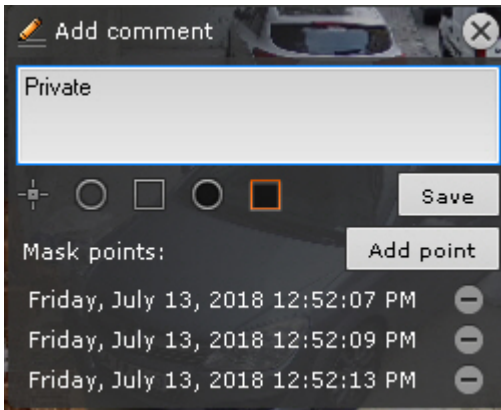

The object is now hidden. When viewing the Video Footage, users without appropriate access rights will see the object masked.

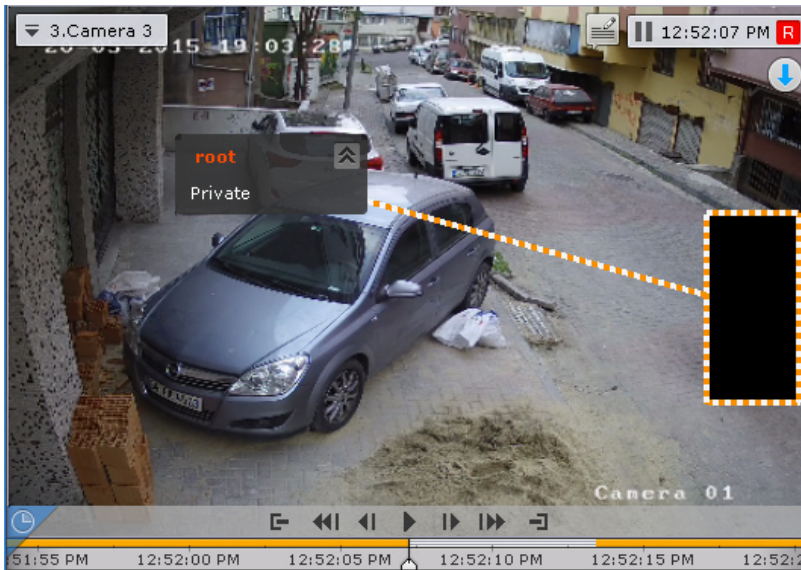

7.10.1.3 Analyzing video from external systems (Offline Analytics)

You can run *Axxon Next* analytics on any video file from either external or internal storage.

To do this, you need to [import](#) the video file and [index](#) it.

After that, you will have the following options available:

1. [Forensic Search for Fragments \(MomentQuest\)](#).
2. [Face search](#).
3. [LPR search](#).
4. [Searching comments](#).

Note

You can search only by text comments entered after the video is imported.

5. [Compressed playback of archives \(TimeCompressor\)](#).

Select a mirror archive (see [Selecting an Archive](#)) to run video analytics on and **Offline analytics** for metadata source (see [Forensic Search for Fragments \(MomentQuest\)](#)).

7.10.1.3.1 Importing video to Axxon Next

To import external video data, do as follows:

1. Create an archive. It must be equal to or larger than the total size of all files in it (see [Creating archives](#)).
2. Run IP Device Discovery Wizard (see [Adding and removing IP devices](#)):
 - a. In the form for manually adding an IP device, select **AxxonSoft** in the **Vendor** drop-down list (1).

IP address 0.0.0.0	Port 3600	Vendor AxxonSoft 1	Username Auto	Bind to the archive Archive AliceBlue 3
Device type IP device	Model ExternalArchive 2	Password ••••	Recording No	

- b. Select **ExternalArchive** from the models list (2).
- c. Select the archive file to which video recordings will be added (3).

- d. Click the  button

Attention!

When you add a camera:

- 1) continuous replication from the on-board storage to the selected archive file (see [Configuring data replication](#));
- 2) the **Scene Analytics** object will be created (see [Creating Detection Tools](#)) and metadata enabled (see [Setting General Parameters](#)).

3. Configure **Object Tracking** (see [Setting General Parameters](#)). If you want to find persons and car numbers in video footage, then create and configure the appropriate detection tools (see [Configuring License plate recognition \(VT\)](#), [Configure Facial Recognition](#)).

Attention!

Do not remove the Object Tracker from your system. Otherwise you cannot import videos into your system.

4. If necessary, change the mode of data replication (see [Configuring data replication](#)). If you select **On Demand** mode you can start the analysis of the video image manually (see [Indexing video from external sources](#)).

Attention!

Replication is performed only to the end of the archive. It is not possible to overwrite existing data in the archive (see [Configuring data replication](#)).

If you ignore this rule, the videos will not be indexed.

It's preferable to import all the videos from a folder at once, otherwise you have to manually remove metadata and records from the Archive before the next replication (see [Indexing video from external sources](#)).

5. In the **Folder** field, specify the storage location of the video footage that will be used as External Archive.

High-quality video stream	0. RAW
Compression Rate	1
Frames per second (fps)	25
Resolution	100 x 100
Video Codec	RAW
vstream-virtual/folder	E:/Video
Low-quality video stream	0. RAW
Adaptive video stream	Disabled

Attention!

The following compression algorithms are supported: MJPEG, MPEG-2, MPEG-4, MxPEG, H.264, H.265, Hik264 (x86 only) as well as uncompressed ('raw') video.

A "raw" format is a stream of consecutive frames without time stamps.

6. Imported folders with video footage or video files must be ISO 8601 timestamped: YYYYMMDDTHHMMSS.
- If the timestamp is in the folder name, all the videos starting from the specified date and time will be imported without exception. The video recordings are ordered according to the file name as follows:

Note

For example, if the **20160719T100000_camera1** folder contains 3 files (1.avi, 2.avi, 3.avi), they will come into the archive as follows:

1.avi: [19 July 2016, 10:00:00; 19 July 2016, 10:00:00 + the duration of 1.avi].

2.avi: [19 July 2016, 10:00:00 + the duration of 1.avi; 19 July 2016, 10:00:00 + the duration of 1.avi and 2.avi].

3.avi: [19 July 2016, 10:00:00 + the duration of 1.avi and 2.avi; 19 July 2016, 10:00:00 + the duration of 1.avi and 2.avi and 3.avi].

- If the folder name does not have the timestamp, all the video files will be imported in accordance with their timestamps. If the file name is incorrect, the starting point of the recording on the timeline will correspond to the modification date of the file.

Attention!

Axxon Next operation may be incorrect if video recordings in the folder overlap. No error messages are displayed in this case.

The date in the folder name or file name (or their creation dates) may not precede the metadata storage period as defined in the system (see [Configuring storage of the system log and metadata](#)).

If you add a **Z** character to the end of the timestamp, the time zones for the videos will be GMT +0, otherwise – the time zone of the Server.

For example, 20150701T165130Z.avi. In the Archive mode, this video recording will fit into the timeline from 1 July 2015, 16:51:30 GMT +0 to July 1, 2015, 16:51:30 + recording time GMT +0.

7. Click the **Apply** button.

7.10.1.3.2 Indexing video from external sources

By default, indexing starts automatically after specifying video files (see [Importing video to Axxon Next](#)).

This may take a while and increase the CPU usage. Similar to the export process, the status of the indexing process is displayed at the top of the screen (see [Viewing export progress](#)) and in the viewing tile.





Attention!

You should not view the replicated archive during indexing.
 Also, do not run multiple simultaneous indexing procedures.

If you set the **On demand** replication period (see [Configuring data replication](#)), then to start the indexing procedure select **Start import process (1)** from the context menu of the viewing tile.

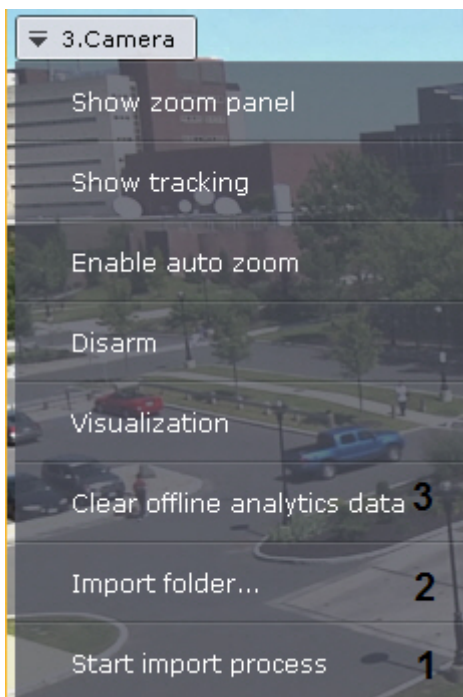

If you want to index the video from another folder, click **Import folder (2)**, or click  in the viewing tile.

Attention!

If you change the folder, all files in Mirror Archive and metadata will be lost.

Attention!

You can select only the folder specified in the settings and its sub-folders

To remove metadata and video from an archive, select **Clear offline analytics data (3)** and confirm file formatting.

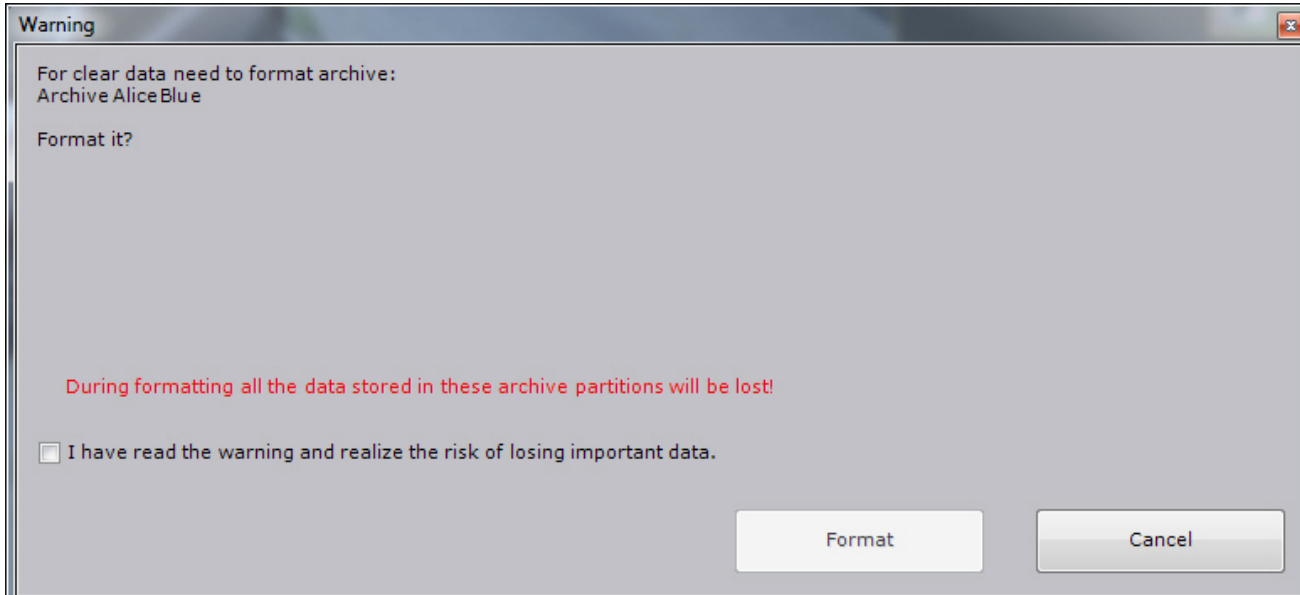

7.10.1.3.3 How to set a folder to import videos from

If you need videos from a different folder on Server to be indexed in addition to already processed footage, you can select only the folder specified in the settings, and its sub-folders (see [Indexing video from external sources](#)).

To specify the folder, do the following:

1. Go to **Settings->Options->Import (1-2)**.

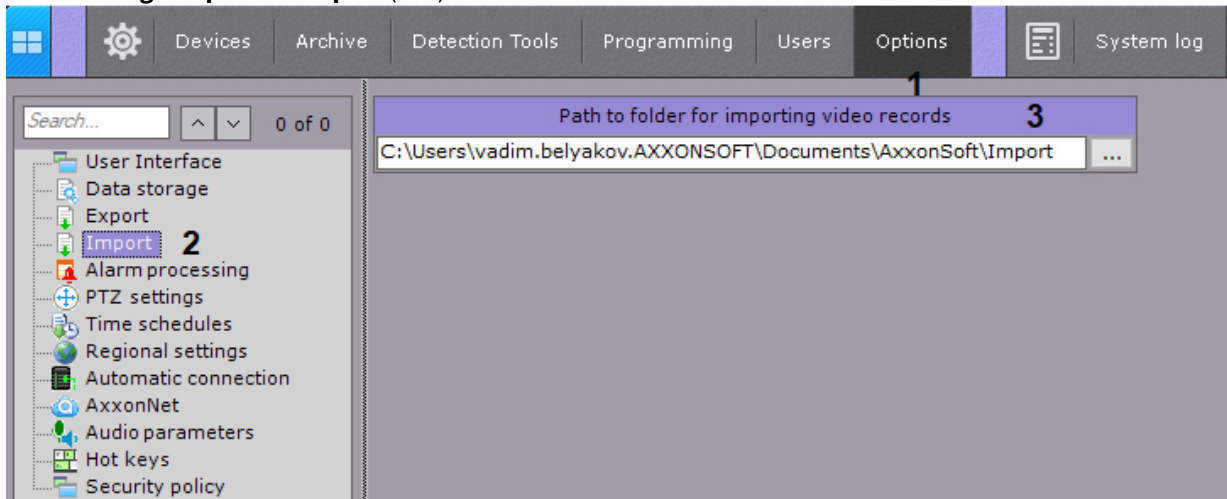

2. Specify the path to the folder (3).
3. Click the **Apply** button.

7.10.1.4 Configuring hardware video decoding for display on the Client

In Axxon Next, there are two ways for hardware accelerated video decoding:

1. Using Intel Quick Sync Video (see [Hardware-based decoding with Intel Quick Sync Video](#)).
2. Using the NVDEC chip on NVIDIA graphics cards (see [Hardware-based decoding with NVIDIA NVDEC chips](#)).

In addition, decoding with both Intel QSV and NVDEC is possible (see [Parallel decoding with both Intel's Quick Sync Video and NVIDIA's NVDEC](#)).

7.10.1.4.1 Hardware-based decoding with Intel Quick Sync Video

Intel Quick Sync Video (QSV) is a technology available on some Intel processors, that provides hardware acceleration for video encoding/decoding. QSV offloads video encoding/decoding to a dedicated hardware CPU core, providing faster results and reducing the video footprint on server CPU performance.

Attention!

Axxon Next applies Intel QSV for decoding:

1. Video formats: H.264, H.265 and H.265 +.
2. Live, Archive modes (forward playback only) and [TimeCompressor](#).

Attention!

If the Client shares the same PC with a Server which applies a detection tool to a video stream, Intel Quick Sync Video will not be used for displaying this stream.

Note

Maximum pixel resolution depends on your particular version of the Intel Quick Sync core; refer to <https://www.intel.com/content/www/us/en/homepage.html> for details.

To use Intel Quick Sync Video, make sure your system meets the following requirements:

1. Since QSV is incorporated into the graphics processor, your CPU must have one (iGPU).

Note

You can check if the CPU supports QSV [here](#).

Attention!

For H.265 and H.265 + video, Intel Quick Sync Video technology is supported only on Intel processors with microarchitecture: Braswell (only decoding), Cherry Trail (only decoding), Skylake, Apollo Lake, Kaby, Gemini, Coffee Lake.

2. The mainboard supports iGPU (includes [Flexible Display Interface](#)).
3. The Graphics driver supports QSV. We recommend using the latest version of [the Intel HD Graphics Driver](#).

Note

You can also update the driver automatically using the [Intel Driver Update Utility](#) utility.

To activate the Intel QSV in *Axxon Next* you need to:

1. Enable using the integrated graphics option in the BIOS settings.

Note

Depending on the BIOS version, it may be named differently (**iGPU** , **Internal Graphics** , **Integrated Graphics Adapter - PEG**).

2. In general, the simultaneous use of the integrated graphics unit (iGPU) and external GPU has to be avoided. In this case, to use Intel QSV, do as follows:
 - a. Enable **Multi-Monitor** in the BIOS settings.
 - b. Connect a “Fake/Virtual” Monitor/Display on Windows and then connect it to your iGPU and select Extend desktop to this display in the Multiple displays list.
3. Go to **Settings** → **Options** → **User interface (1-2)**.

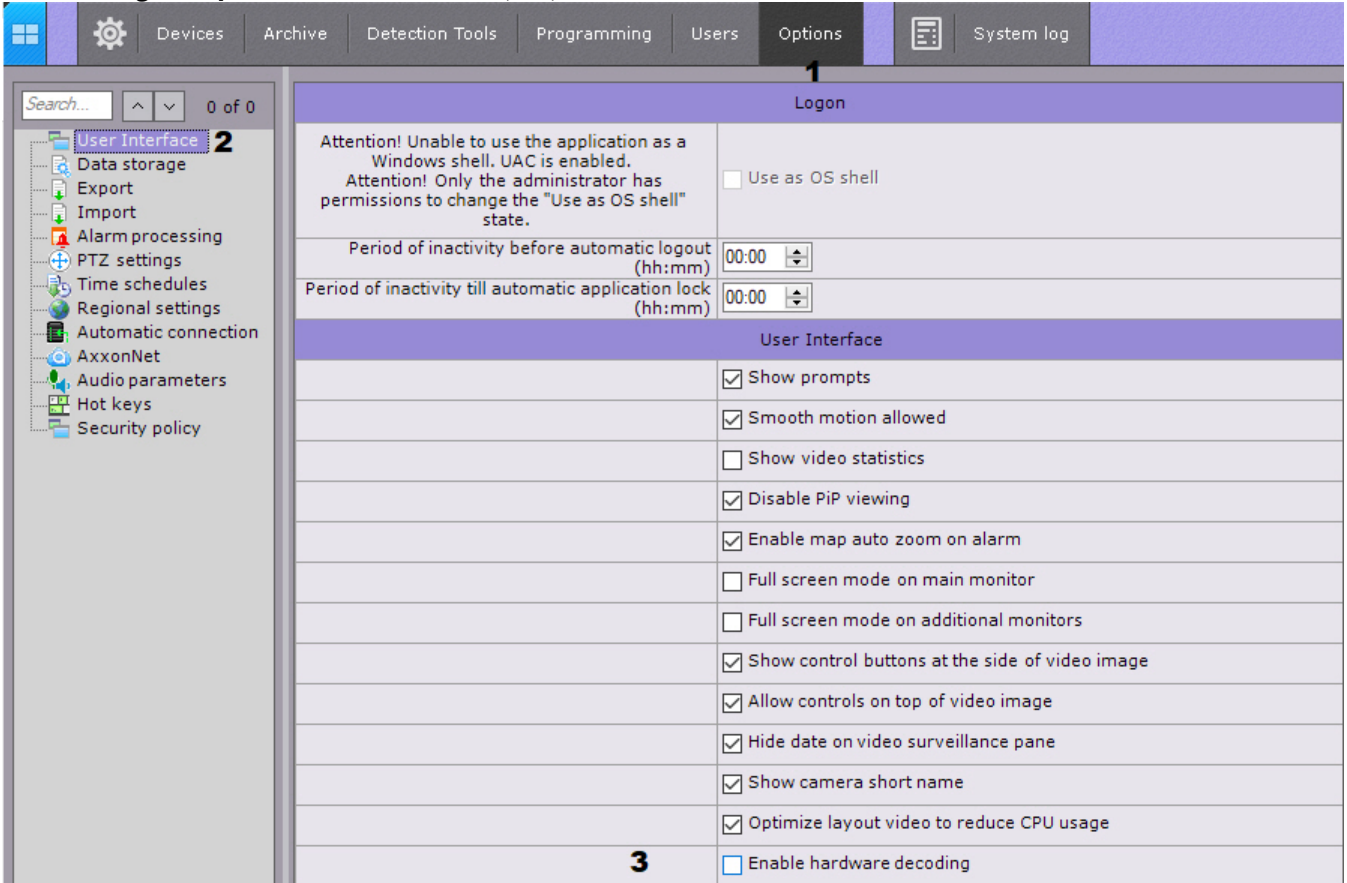

4. Select the **Enable Hardware Decoding** checkbox (3).
5. Click **Apply** to save the changes.

7.10.1.4.2 Hardware-based decoding with NVIDIA NVDEC chips

NVIDIA GPUs contain a hardware-based decoder (a chip referred to as NVDEC) which provides fully-accelerated hardware-based video decoding for several popular codecs. With complete decoding offloaded to NVDEC, the graphics card and the CPU are free for other operations and you can increase the number of video cameras displayed on the Client.

In addition, if you have the NVDEC dedicated hardware video decoder running on Servers, you can get video streaming directly to GPU (see [Detection tools implementation on processors](#)) for analysis and detection purposes, bypassing RAM.

Attention!

In *Axxon Next VMS*, the NVDEC chips are used to decode:

1. video compressed with the following codecs: H.264, H.265 and MPEG-2.
2. In Live Video, Archive Video, and [TimeCompressor](#).

Attention!

Before you start, please make sure to install the latest driver for your NVIDIA GPU.

Note

Please see the list of supported devices for the NVDEC chips on the [NVIDIA official website](#).

When decoding with NVDEC, the following limitations apply:

1. Maximum video resolution for H.264 - 4096x4096.
2. Maximum video resolution for H.265 - 8192x8192.
3. The maximum total frame rate per second for the H.264 codec is 648 fps.

To enable decoding with NVDEC, do as follows:

1. Go to **Settings** → **Options** → **User interface (1-2)**.

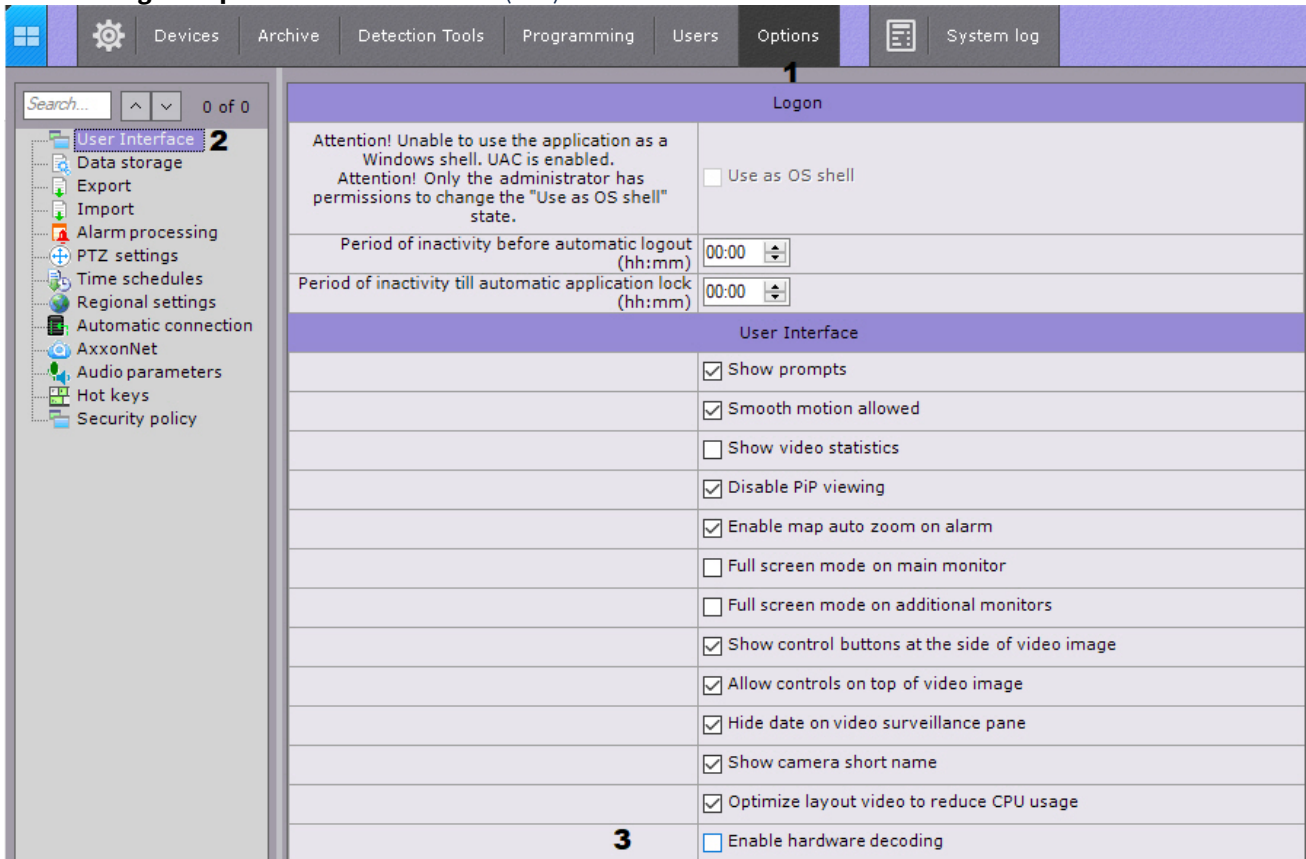

2. Select the **Enable Hardware Decoding** checkbox (3).
3. Click **Apply**.

7.10.1.4.3 Parallel decoding with both Intel's Quick Sync Video and NVidia's NVDEC

In Axon Next, decoding with both Intel QSV and NVDEC is possible.

In this case, NVIDIA devices are the first to take up the decoding job. Then, if they max out, Intel QSV takes over and offloads NVIDIA's chip.

For simultaneous decoding, you have to configure it on both Intel Quick Sync Video (see [Hardware-based decoding with Intel Quick Sync Video](#)) and Nvidia's NVDEC chips (see [Hardware-based decoding with NVIDIA NVDEC chips](#)).

7.10.1.5 Configuring automatic response when Axon Next VMS PC integrity check fails

When you start Servers and Clients, Axon Next automatically checks the digital signature for all executable files (exe, dll, so).

If all files are in place and match their signatures, the "System integrity check passed successfully" record appears in the system log (see [The System Log](#)).

Otherwise, you can set the system to automatically perform one of the pre-configured actions. To select a response, do as follows:

1. Select **Settings-> Options -> Security Policy (1-2)**.

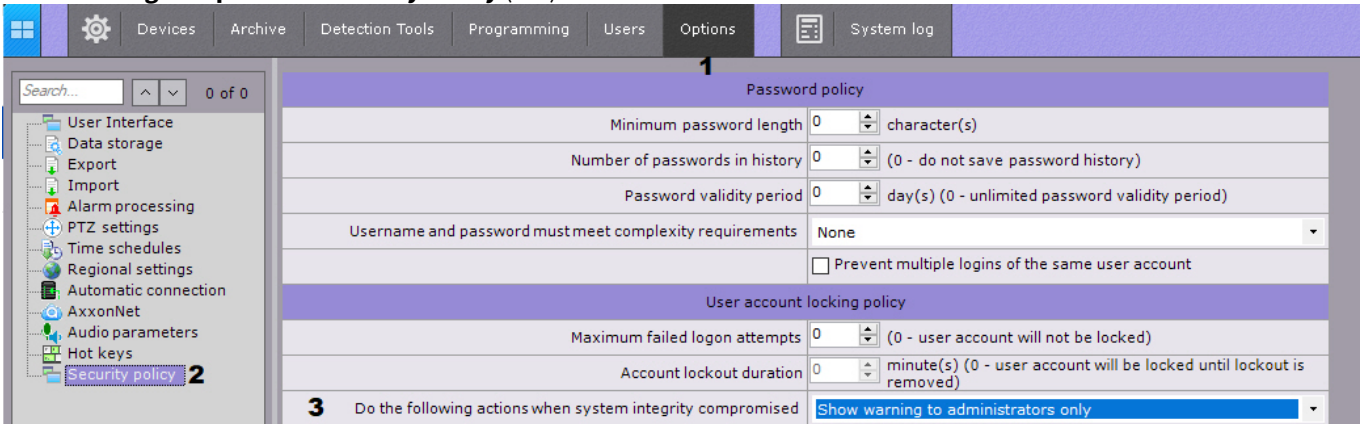

2. From the **Do the following actions when system integrity compromised (3)** choose the necessary response:
 - a. **Show warning to administrators only** - if selected, when the Client starts , an alert will be displayed for users of the **admin**.

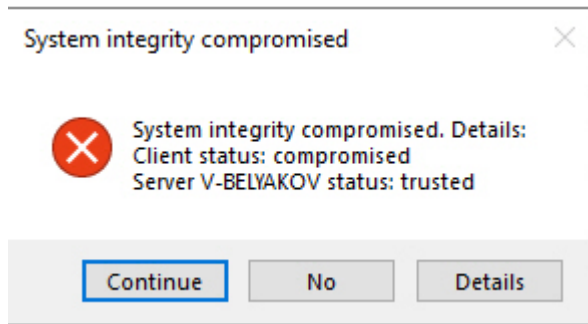

Note
 To resume launching the Client, click **Continue**; to quit, click **No**. To open a text file containing the list of compromised files, click **Details**.

- b. **Show warning to all users** - in this case, all users will be alerted.
- c. **Block users without admin rights** - allows only users in the **Admin** role to access the Server.
- d. **Stop non-vital services** - shuts down all system objects that are subject to licensing (video cameras, detection tools, etc.). Upon launching the Client, each user will see a notification message.

3. Click **Apply**.

7.10.1.6 Configuring storage of the system log and metadata

The system log is a log containing system information on events, including system error entries.

The system log is stored in a local database for each server. You can set access to the system log for a user group in the **Users** tab under **Settings** (see the section titled [Configuring user permissions](#)).

By default, metadata files are stored in Server's object trajectory database: C:\Program Files\AxxonSoft\AxxonNext\Metadata\vmda_db\VMDA_DB.0\vmda_schema; if necessary, you can place them on any available network storage.

To configure storage of the system log and metadata:

1. Go to **Settings** → **Options** → **User interface (1-2)**.

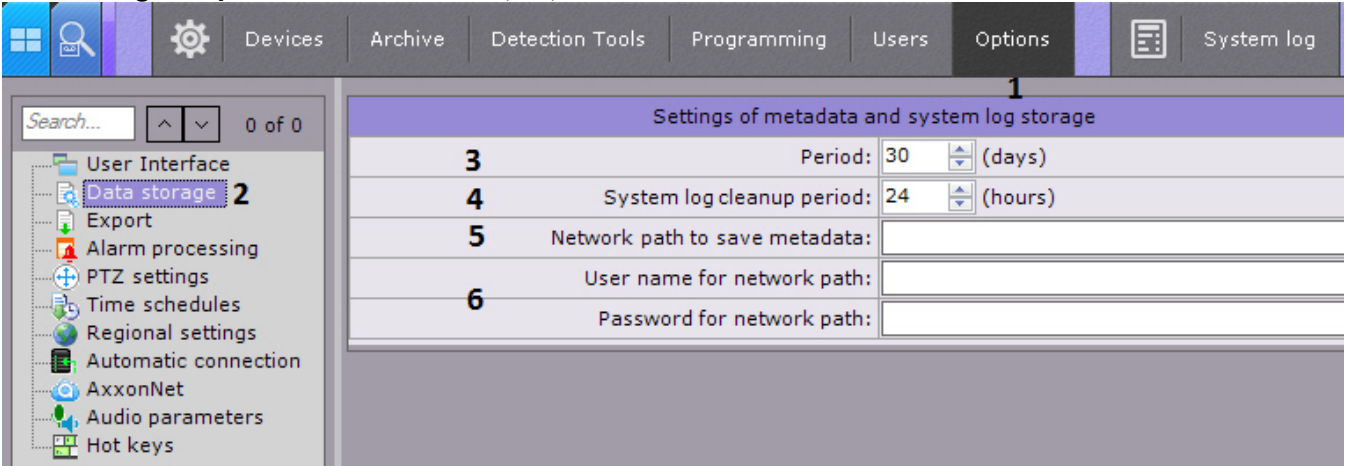

2. In the **Period** field, enter the amount of days to store the system log in the Server’s database and to store metadata in the object trajectory database (**3**). The maximum time is 1000 days.

Attention!

If you enter **zero** value:

- System Log events will be stored 0 days;
- metadata retention time becomes unlimited.

Attention!

If you have less than 15 GB of free disk space, the Object Tracking DB is overwritten - new data records over the oldest data records.

3. In the appropriate field, enter the amount of hours after which outdated events will be purged from the system log (**4**). Outdated events are events that have been stored in the system log for a period greater than that indicated in step 2.

Note

The object trajectory database is purged of video recordings that have been stored for more than the specified storage period:

1. Every 12 hours after *Axxon Next* is started.
2. Every time you start the MomentQuest forensic search tool (see [Forensic Search for Fragments \(MomentQuest\)](#)).

If the camera is not recording when DB is cleaned up, then its recordings are preserved irrespective of their timestamp.

4. The metadata database can be stored on NAS if necessary (by default, it is located locally as set during [Installation](#)). Do the following:
 - a. Enter a path to the network destination for metadata database (**5**).
 - b. Enter the user name and password (**6**). The user must have permissions to access the NAS.

Note

If you clear the path to NAS, metadata will be stored in the local database again

5. Click the **Apply** button.

Configuration of the system log is now complete.

7.10.1.7 Configuring Alarm Management Mode

You can set the following parameters for alarm handling:

1. The maximum allowed reaction time to an alarm is the length of time from the moment the operator who accepted an alarm for processing exits alarm mode, after which the alarm returns to **New** status, and the count for the allowed time for ignoring an alarm begins again.

Note

For example, an operator can exit alarm mode to view the video archive related to the alarm

2. Requirement for comments when classifying alarms in Alarm Management mode.

To configure alarm handling in the system, you must perform the following steps:

1. Go to **Settings** → **Options** → **Alarm processing (1-2)**.

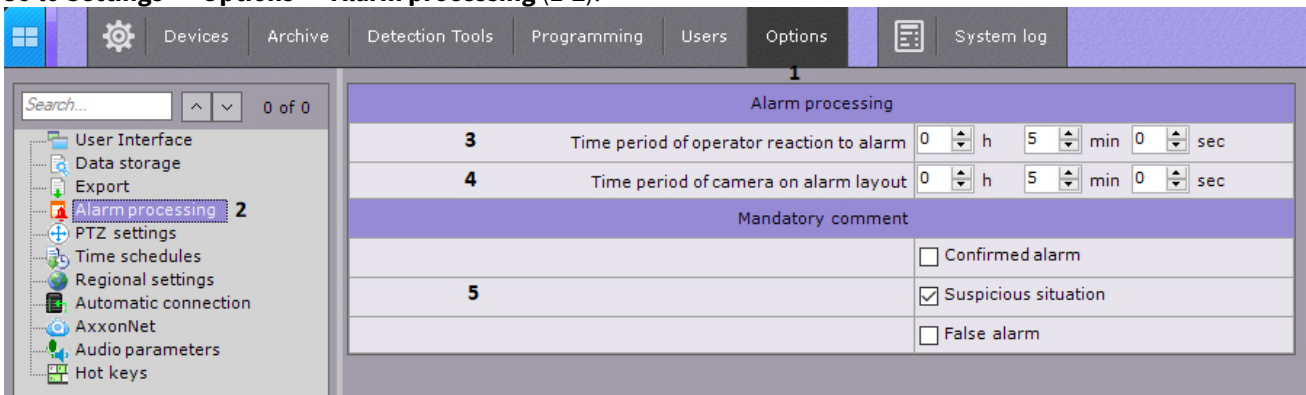

2. In the **Time period of operator reaction to alarm** field, enter the time during which an operator who accepted an alarm for processing and exited alarm mode without evaluating it must return to alarm mode (**3**). The minimum value is 2 minutes.
3. Set the maximum dwell time for alarms on the Special Layout (**4**). After the dwell time has elapsed, the alarm will be removed from the layout and the next one shows.
4. Select the alarm classifications for which you want to require comments (**5**).
5. Click the **Apply** button.

Configuration of alarm handling is now complete.

7.10.1.8 Configuring PTZ control

To configure PTZ control, do as follows:

1. Go to **Settings** → **Options** → **PTZ Settings (1-2)**.

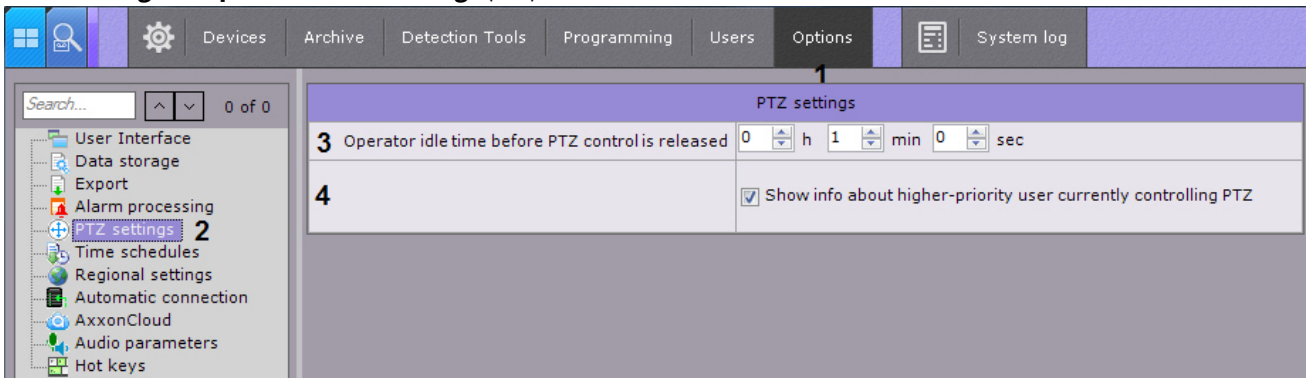

2. Set the operator idle time in hours, minutes and seconds (3). When the time runs out, PTZ control is unlocked automatically if the operator did not carry out any action.
3. By default, if the user with a higher priority controls the PTZ camera, then the PTZ control panel displays the name of the user. To disable displaying this information, deselect the corresponding checkbox (4).
4. Click the **Apply** button.

You have configured PTZ control.

[Controlling a PTZ Camera](#)
[Creating and configuring roles](#)

7.10.1.9 Configuring schedules

A schedule consists of all the time intervals for which video streams from video cameras will be recorded to archive.

7.10.1.9.1 Creating schedules

To create a schedule, complete the following steps:

1. Go to **Settings** → **Options** → **Time Schedules (1-2)**.

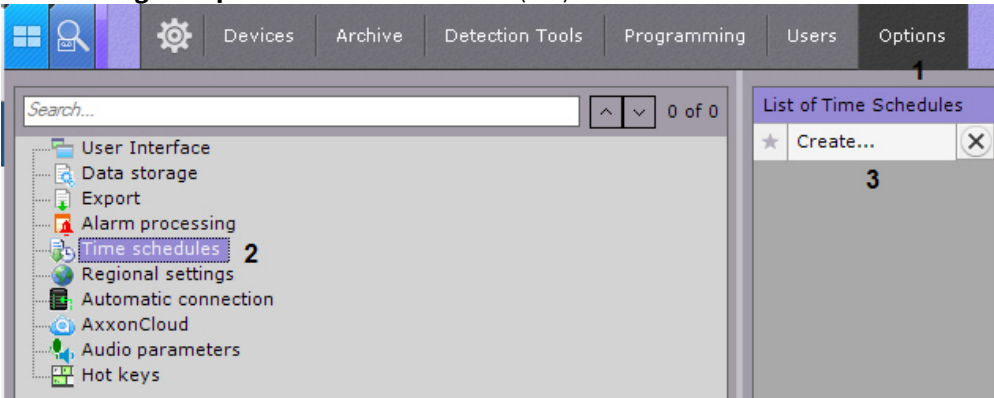

2. In the **List of schedules**, enter the name of the required schedule (3) and click .
3. Set the time intervals for the schedule:
 - a. Enter the interval's start time in the **From** column with the help of the buttons accessible by left-clicking the appropriate cell twice (1).

Time schedule intervals		3										
1	From	2	To	Mon	Tu	Wed	Thurs	Fr	Sat	Sun	All	
	00:00		08:00	<input type="checkbox"/>	<input type="checkbox"/>	<input type="checkbox"/>	<input type="checkbox"/>	<input type="checkbox"/>	<input checked="" type="checkbox"/>	<input checked="" type="checkbox"/>	<input type="checkbox"/>	<input type="checkbox"/>
	08:00		18:00	<input checked="" type="checkbox"/>	<input checked="" type="checkbox"/>	<input checked="" type="checkbox"/>	<input checked="" type="checkbox"/>	<input checked="" type="checkbox"/>	<input type="checkbox"/>	<input type="checkbox"/>	<input type="checkbox"/>	<input type="checkbox"/>
★	00:00		00:00	<input type="checkbox"/>	<input type="checkbox"/>	<input type="checkbox"/>	<input type="checkbox"/>	<input type="checkbox"/>	<input type="checkbox"/>	<input type="checkbox"/>	<input type="checkbox"/>	<input type="checkbox"/>

Button	Action
	Shift the interval start back by 1 hour
	Shift the interval start back by 5 minutes
	Shift the interval start ahead by 5 minutes

Button	Action
	Shift the interval start ahead by 1 hour





- Enter the interval's end time in the **To** column with the help of the buttons accessible by left-clicking the appropriate cell twice (2).
- Select the days of the week to be included in the interval by selecting the appropriate check boxes (3).
- Create the necessary number of intervals to be included in the schedule





Note

To delete a time interval, click  in the corresponding row

A visual display of time intervals for each day of the week is provided on the time chart.

List of Time Schedules

-  Timezone 1 
-  Create... 

Time schedule intervals		Mon	Tu	Wed	Thurs	Fr	Sat	Sun	All	
From	To	<input type="checkbox"/>	<input type="checkbox"/>	<input type="checkbox"/>	<input type="checkbox"/>	<input type="checkbox"/>	<input checked="" type="checkbox"/>	<input checked="" type="checkbox"/>	<input type="checkbox"/>	
00:00	08:00	<input checked="" type="checkbox"/>	<input checked="" type="checkbox"/>	<input checked="" type="checkbox"/>	<input checked="" type="checkbox"/>	<input checked="" type="checkbox"/>	<input type="checkbox"/>	<input type="checkbox"/>	<input type="checkbox"/>	
08:00	18:00	<input checked="" type="checkbox"/>	<input checked="" type="checkbox"/>	<input checked="" type="checkbox"/>	<input checked="" type="checkbox"/>	<input checked="" type="checkbox"/>	<input type="checkbox"/>	<input type="checkbox"/>	<input type="checkbox"/>	
00:00	00:00	<input type="checkbox"/>	<input type="checkbox"/>	<input type="checkbox"/>	<input type="checkbox"/>	<input type="checkbox"/>	<input type="checkbox"/>	<input type="checkbox"/>	<input type="checkbox"/>	

	0:00	1:00	2:00	3:00	4:00	5:00	6:00	7:00	8:00	9:00	10:00	11:00	12:00	13:00	14:00	15:00	16:00	17:00	18:00	19:00	20:00	21:00	22:00	23:00
Monday																								
Tuesday																								
Wednesday																								
Thursday																								
Friday																								
Saturday																								
Sunday																								

- Click the **Apply** button.

Creation of a schedule is now complete.

[Binding a camera to an archive](#)

[Create Macros](#)

7.10.1.9.2 Deleting a schedule

To delete a schedule, complete the following steps:

- Go to the list of schedules (under **Settings** → **Options** → **Time Schedules**).

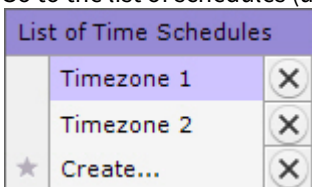

- Click  beside the schedule that you want to delete.

3. Click the **Apply** button.

Deletion of a schedule is now complete.

7.10.1.10 Configuring the Server ports

After the Axxon Next VMS is installed, you can change the port range for Servers, and the NativeBL core port number (see [Ports used by the Axxon Next Software Package](#)).

To change the NativeBL port number, create an NGP_NATIVE_BL_PORT system variable, and set its value to the required port number (see [Appendix 10. Creating system variable](#)).

To change the port range for a Server, use the Network settings utility (see [Network settings utility](#)).

7.10.2 Client settings

7.10.2.1 Configuring the user interface

7.10.2.1.1 Selecting the interface language

When working with *Axxon Next*, the user can choose the interface language.

Attention!

The events are recorded in the system log in the same language as the Server's operating system language.

User apps are run in a selected language with the exception of the System Log which registers events in Server's GUI language.

To select the interface language, complete the following steps:

1. Go to **Settings** → **Options** → **Regional settings (1–2)**.

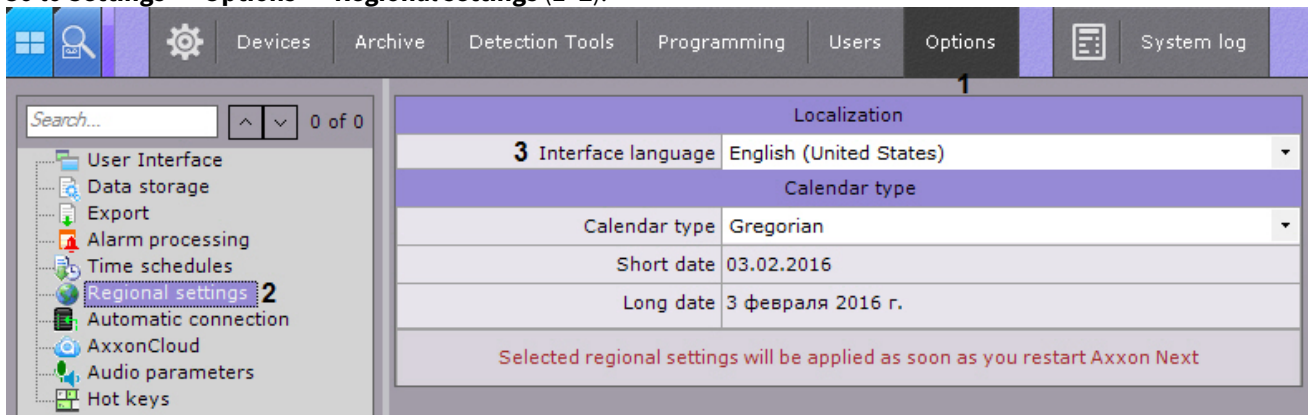

2. Select an interface language from the interface language drop-down list (3).
3. Click **Apply** to save the changes.
4. Restart *Axxon Next*.

The newly selected interface language will be applied once *Axxon Next* is restarted.

To change the events language in system log, do the following:

1. On the Server, go to **Control Panel** → **Clock and Region (Time & Language)**.

Note

Here follows the setup sequence for Windows 10.



2. Select the required language from the **Format** dropdown list.
3. Go to the **Administrative** tab.

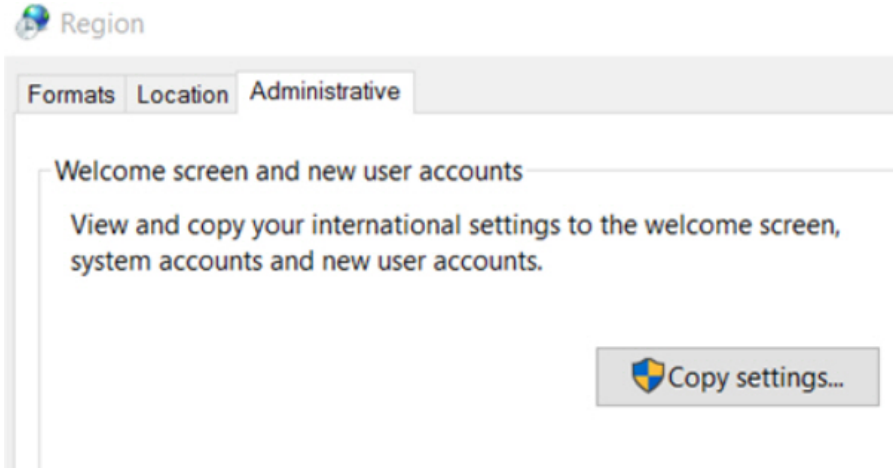

4. Click the **Copy settings** button.

- In the **Copy your current settings to area**, select the **Welcome screen and system accounts** checkbox.



- Click **OK** in two windows, one after another.
- Restart the Server (see [Shutting down a Server, Starting a Server](#)).

7.10.2.1.2 Selecting the calendar type

When working with *Axxon Next*, the user can choose the type of calendar used (Gregorian or Persian).

To select the interface language, complete the following steps:

- Go to **Settings** → **Options** → **Regional settings (1-2)**.

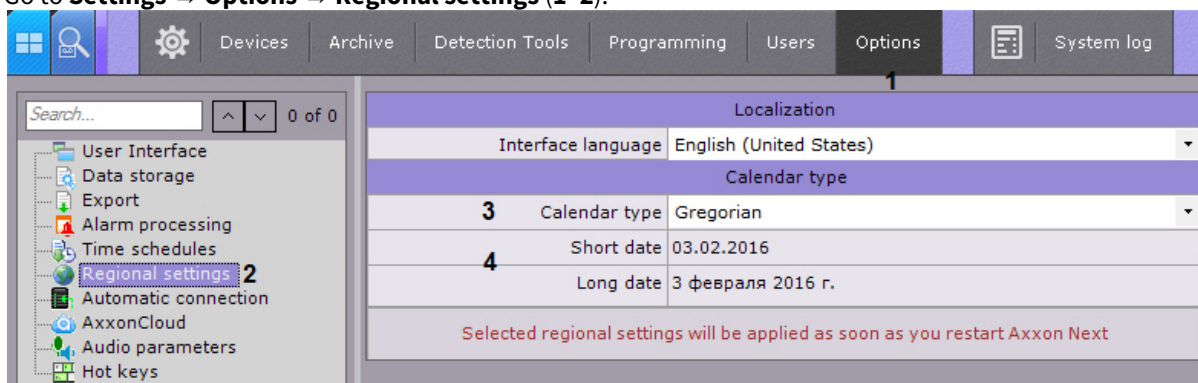

2. Select the calendar type that is used in Axxon Next from the calendar drop-down list (3).

Note

In the *Axxon Next* VMS, time and date formats and values are defined on the OS level (4).

3. Click **Apply** to save the changes.
4. Restart *Axxon Next*.

The newly selected calendar type will be applied once *Axxon Next* is restarted.

7.10.2.1.3 Configuring Slideshow parameters

Slideshow mode is a cyclical switching of layouts according to an assigned frequency (dwell-time). Slideshow is launched using the context menu of the layouts ribbon.

To configure the slideshow dwell-time, perform the following:

1. Go to **Settings** → **Options** → **User interface (1-2)**.

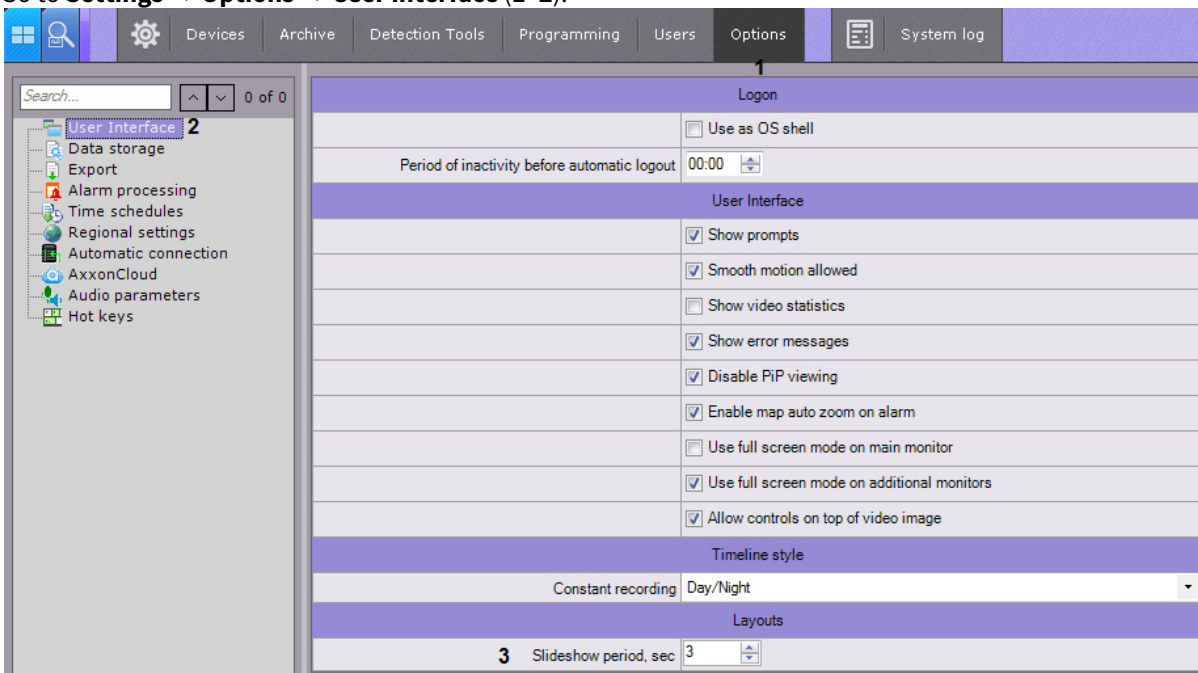

2. Set the slideshow dwell-time, in seconds, in the corresponding field (3).
3. Click **Apply** to save the changes.

The slideshow dwell-time is now set.

Note

Switching layout modes is allowed only for users with **Layout configuration** permissions

7.10.2.1.4 Hiding tooltips

In Axxon Next, tool tips are displayed when the cursor is moved over a control element. Tooltips are enabled by default. To turn off tooltips, perform the following:

1. Go to **Settings** → **Options** → **User interface (1-2)**.

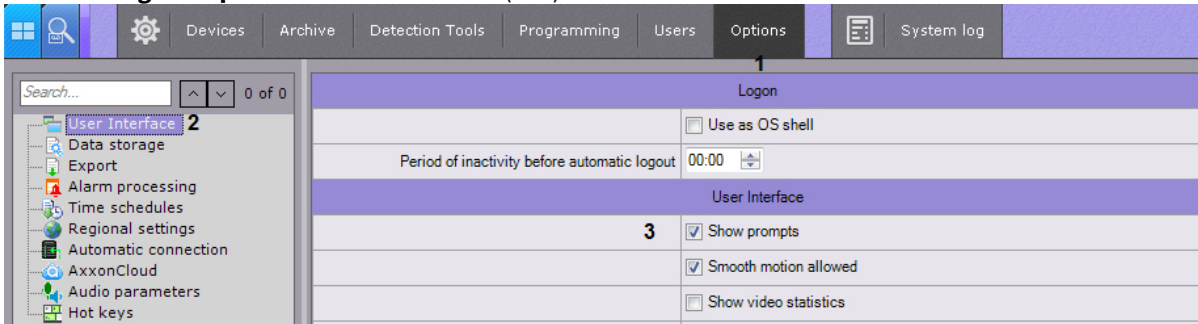

2. Clear the **Show prompts** check box (3).
3. Click **Apply** to save the changes.

Tooltips are now disabled. Tooltips can be re-enabled by simply selecting the **Show prompts** check box.

7.10.2.1.5 Configuring animation

Smooth motion is needed to smoothly change the position of viewing tiles, as well as for smooth switching between tabs. Animation for viewing tiles is enabled by default. To disable this option, perform the following:

1. Go to **Settings** → **Options** → **User interface (1-2)**.

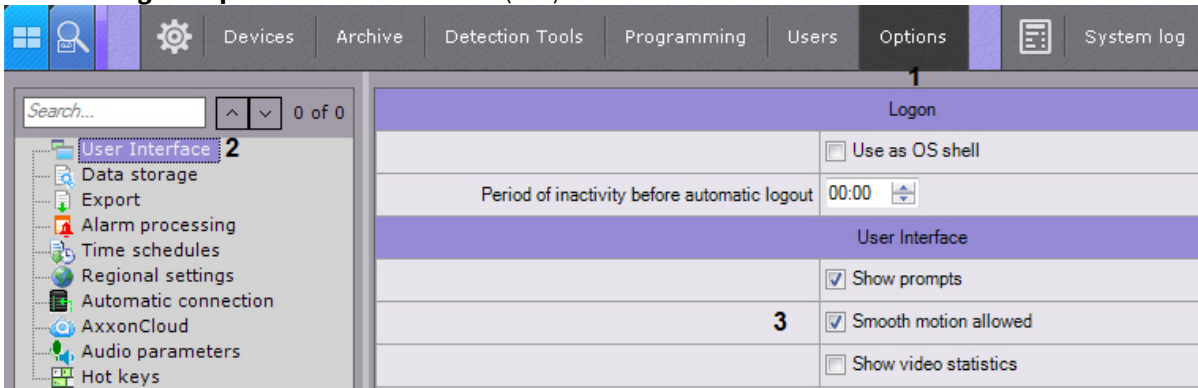

2. Clear the **Smooth motion allowed** check box (3).
3. Click **Apply** to save the changes.

Animation for viewing tiles will now be disabled.

7.10.2.1.6 Configuring Display of Video Statistics

You can display the following video statistics in the viewing tile:

1. Frame rate of the displayed video stream
2. Frame rate of the video stream received from a video camera or an archive
3. Bit rate of a compressed video stream
4. Resolution of the displayed video stream

To use this option you must perform the following steps:

1. Go to **Settings** → **Options** → **User interface (1-2)**.

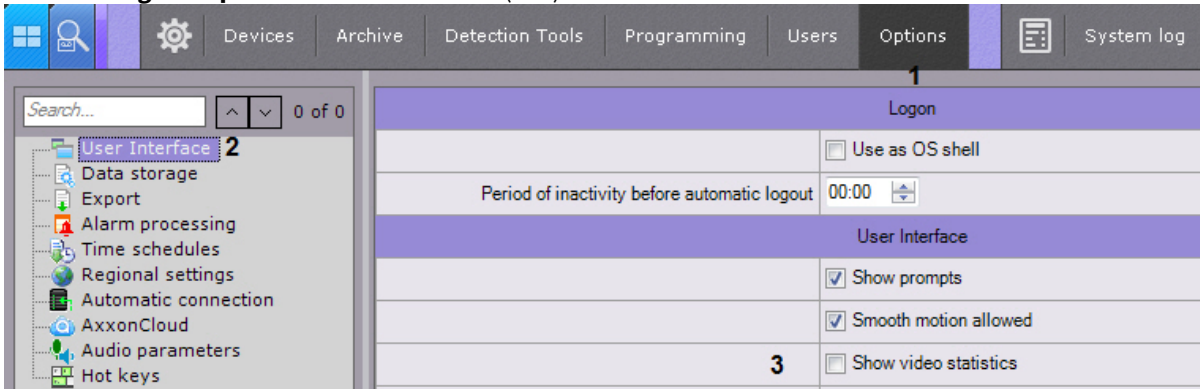

2. Select the **Show video statistics** check box (3).
3. Click **Apply** to save the changes.

The video statistics will now be displayed in the viewing tile for all modes (Live Video, Archive, Alarm, and Archive Search).



7.10.2.1.7 Configuring previews of alarm events

You can disable previews of alarm events in the viewing tile.

To do this, follow the steps below:

1. Go to **Settings** → **Options** → **User interface (1-2)**.

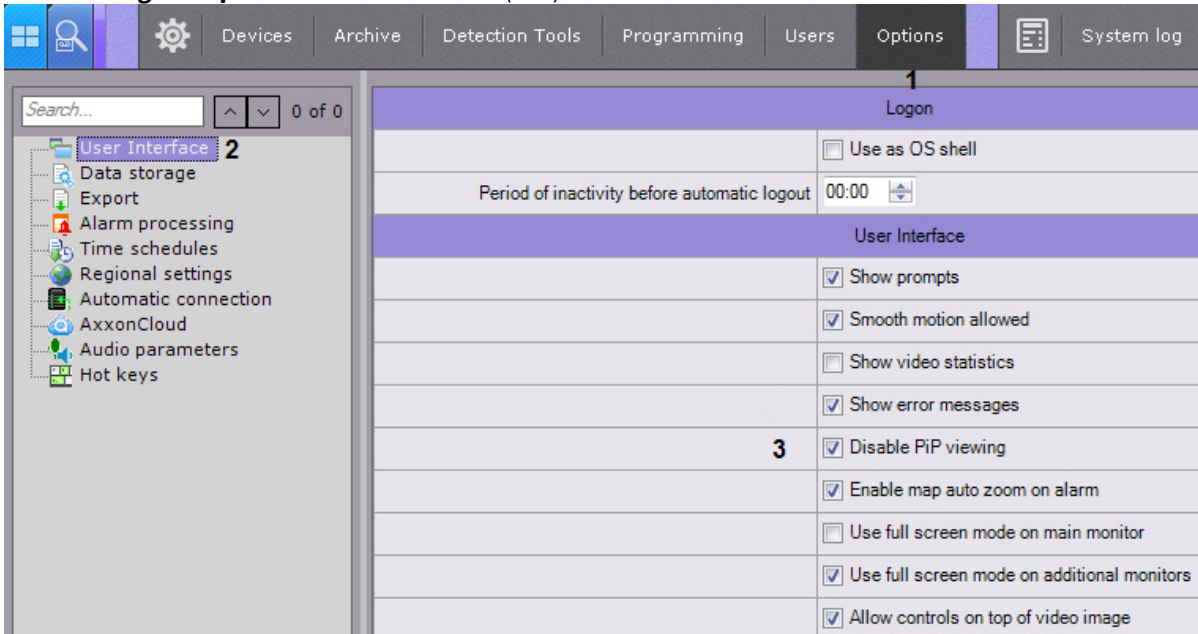

2. Select the **Disable PiP viewing** check box (3).
3. Click **Apply** to save the changes.

After you complete these actions, previews of alarm events will be disabled.

7.10.2.1.8 Configuring map autozoom

When an alarm occurs, the map can be automatically resized and refocused so as to place the icon of the alarm camera at the center of the map. To enable this option:

1. Go to **Settings** → **Options** → **User interface (1-2)**.

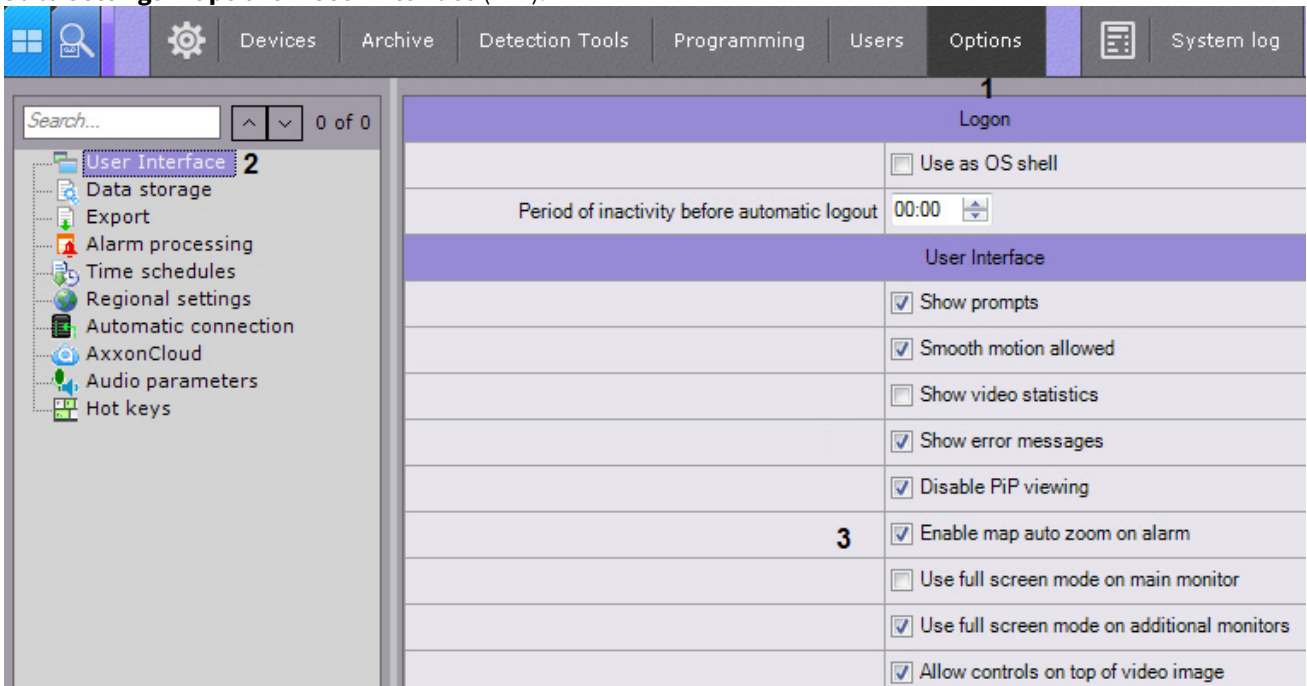

2. Select the **Enable map auto zoom on alarm (3)** check box.
3. Click the **Apply** button to save changes.

7.10.2.1.9 Configuring the Client screen mode (full screen or window)

By default, the Client (main monitor and all additional monitors) is displayed in full-screen mode.

It is possible to use window mode both on the main monitor and on additional monitors. Do the following:

1. Go to **Settings ->Options ->User interface (1-2)**.

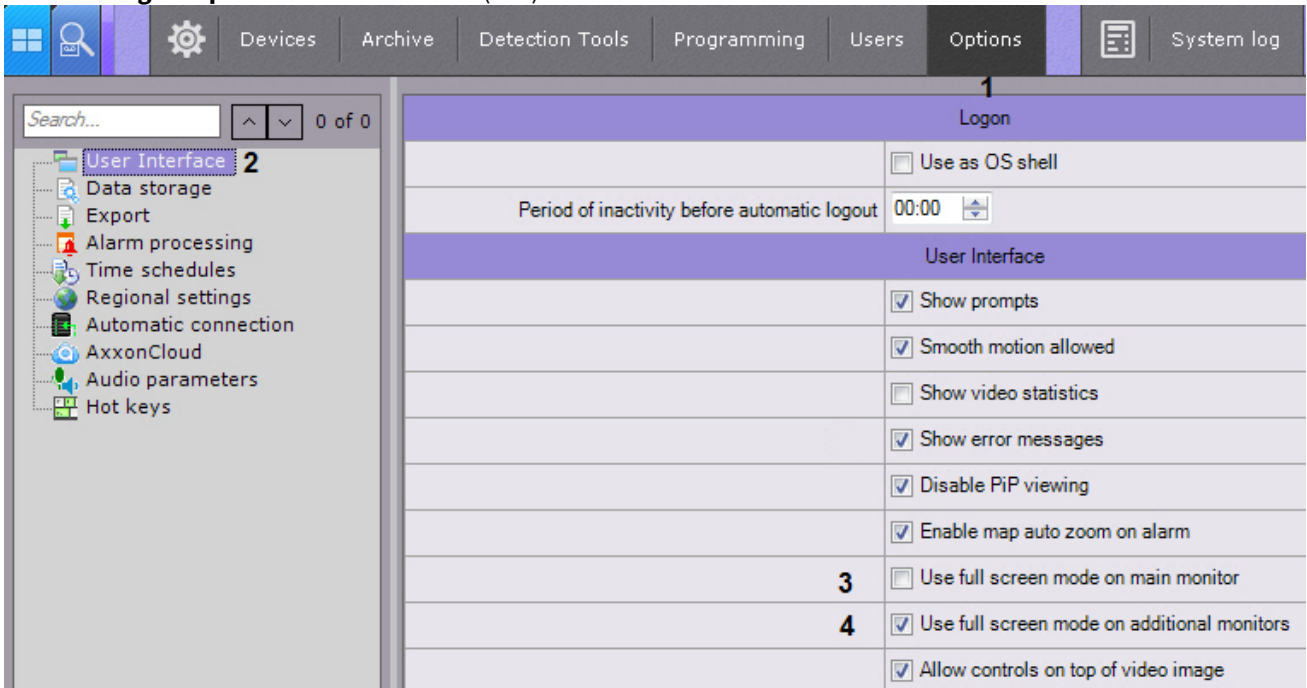

2. To use window mode on the main monitor, clear the **Use full screen on main monitor** check box (3).
3. To use window mode on additional monitors, clear the **Use full screen on additional monitor** check box (4).
4. Click the **Apply** button to save changes.

For changes to take effect, quit the Client and start it again.

7.10.2.1.10 Configuring the Appearance of the Viewing Tile

To configuring the appearance of the viewing tiles:

1. Go to **Settings** → **Options** → **User interface (1-2)**.

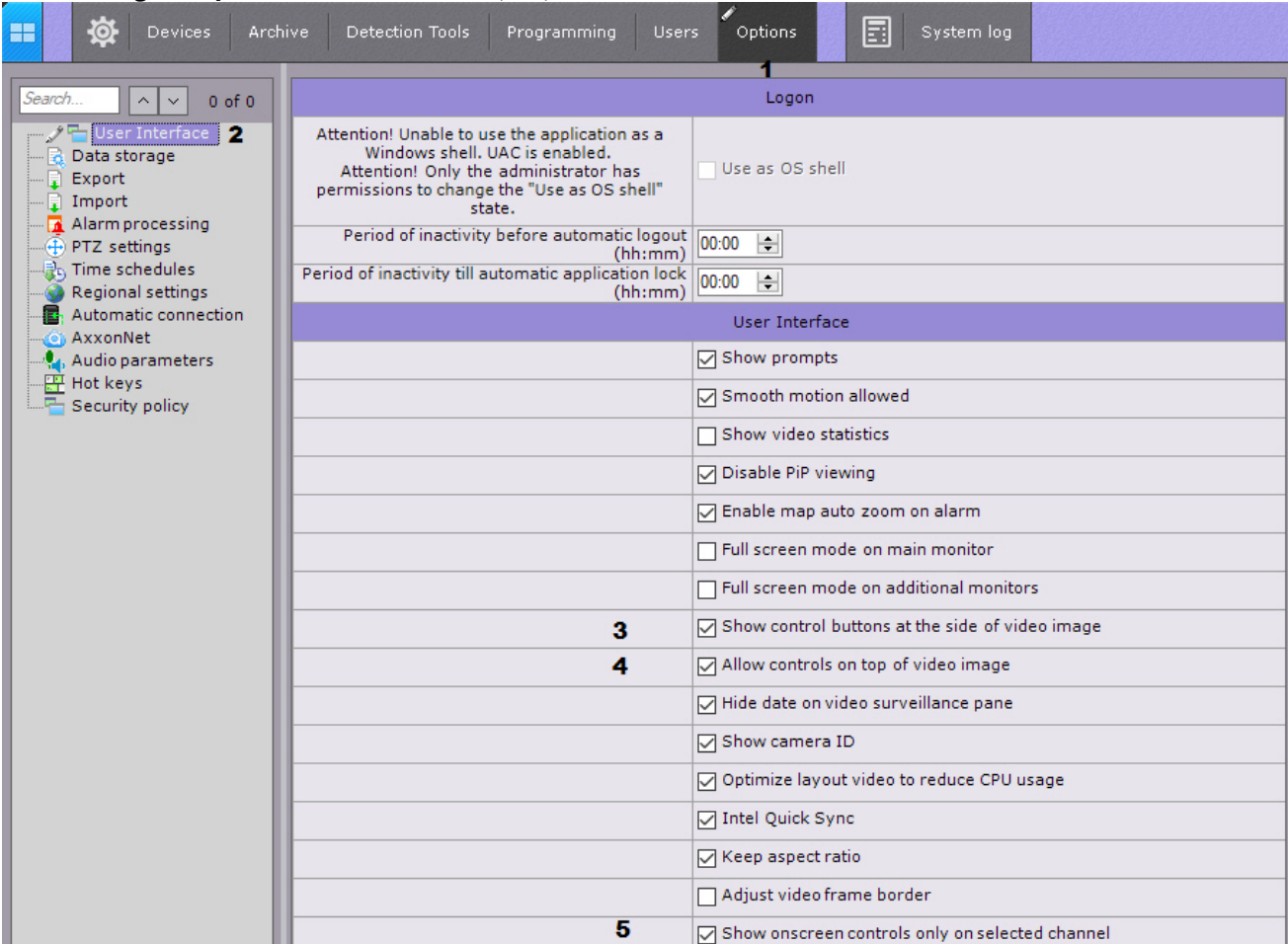

2. By default, surveillance mode selector buttons are located outside the Camera window. If you prefer having them inside the window, uncheck the **Selector Buttons Outside** box (3).

Attention!

In this case, you cannot use digital zoom (in both real time and archive viewing modes) and immersive mode in the Camera window.

3. By default, the Viewing Tile elements (context menus, export buttons, PTZ mode select buttons, etc.) are displayed over the video. To move the controls outside the video area uncheck the **Allow controls on top of video image** checkbox (4).
4. If you don't need to display window elements in other windows than the active one, select the **Show onscreen controls only on selected channel** checkbox (5). This parameter is valid only if the **Allow controls on top of video image** checkbox is selected (4).
5. Click **Apply** to save the changes.
6. Reopen the Layout or create a new one.

7.10.2.1.11 Configure Time Display

By default, the time indicator (see [Time Display](#)) in the viewing tile does not display the date.

To display the date, do as follows:

1. Go to **Settings** → **Options** → **User interface (1-2)**.

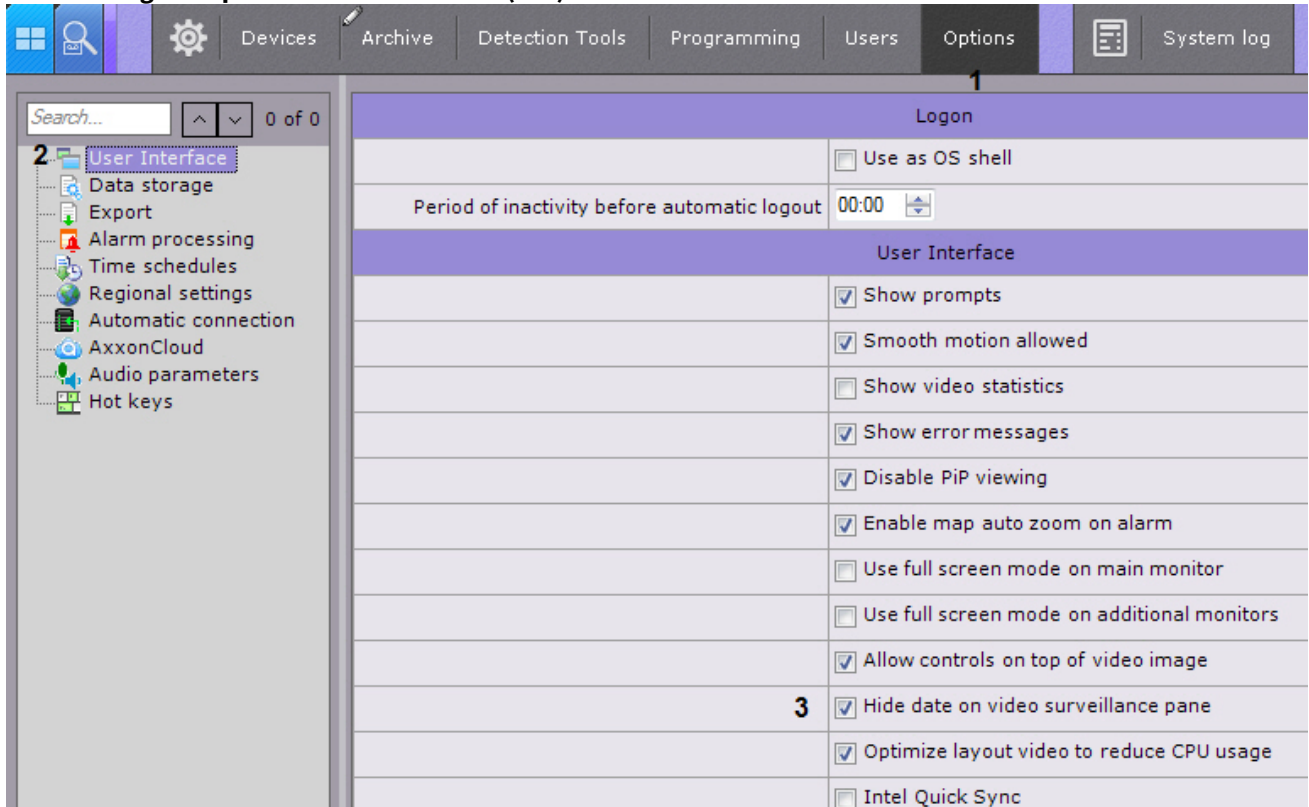

2. Uncheck the **Hide date on video surveillance pane** checkbox (3).
3. Click **Apply** to save the changes.
4. Reopen the Layout or create a new one (see [Layouts Management](#)).

Also, you can hide the time indicator in the camera window. To do it, follow the steps below:

1. Go to Role settings (see [Creating and configuring roles](#)).
2. In **Access to Functions** set **No** for **Unlock camera menu button**.
3. Set the camera access level - **Live**.

This will hide the time indicator for user with this role's permissions on all target cameras.

7.10.2.1.12 Configuring the display of the camera ID

By default, camera ID is displayed in the viewing tile.



To disable displaying the ID, do as follows:

1. Go to **Settings** → **Options** → **User interface (1-2)**.

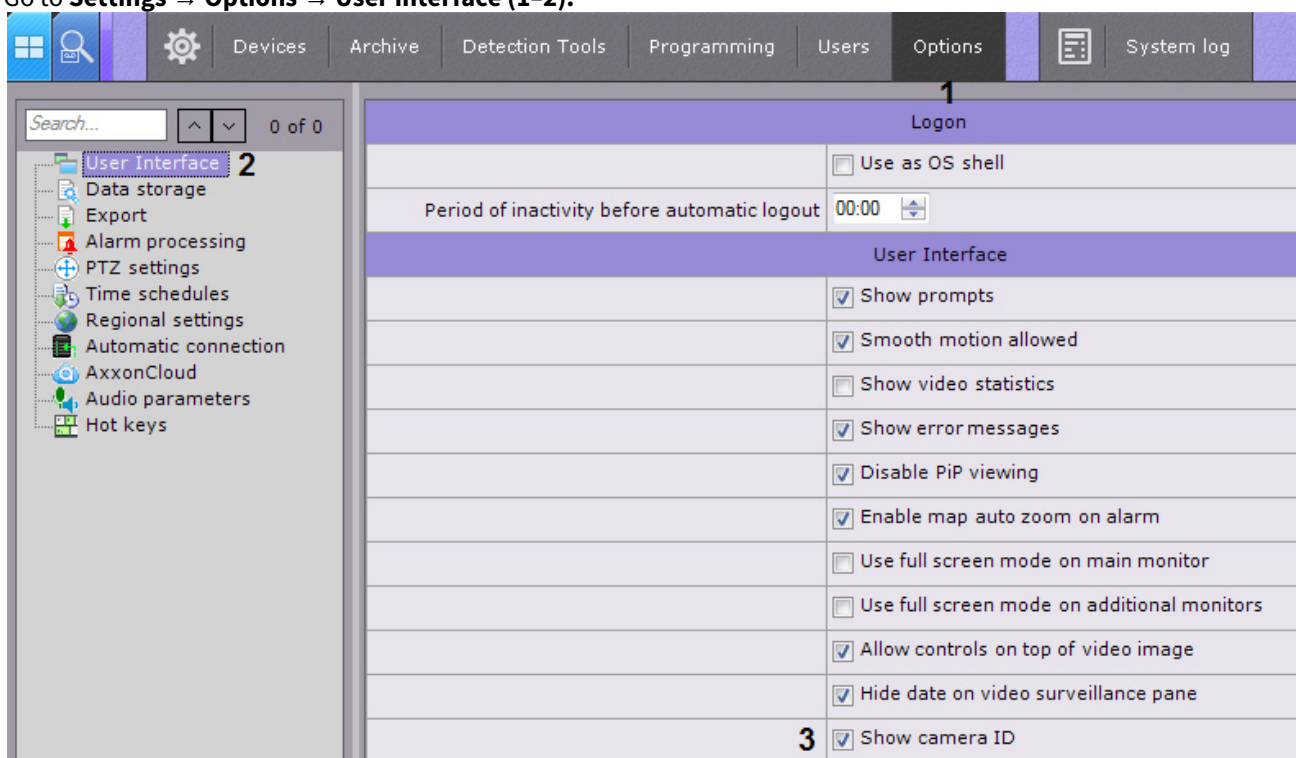

2. Uncheck the **Show camera ID** checkbox (3).
3. Click **Apply** to save the changes.
4. Reopen the Layout (see [Layouts Management](#)).



7.10.2.1.13 Prune Video to Window Resolution

You can cut (prune) video resolution to fit the resolution of the viewing tile. This makes sense when the camera window (i.e. viewing tile) resolution is smaller than that of the video feed. This allows conserving CPU and bandwidth.

Video optimization is enabled by default. To disable, do as follows:

1. Go to **Settings** → **Options** → **User interface (1-2)**.

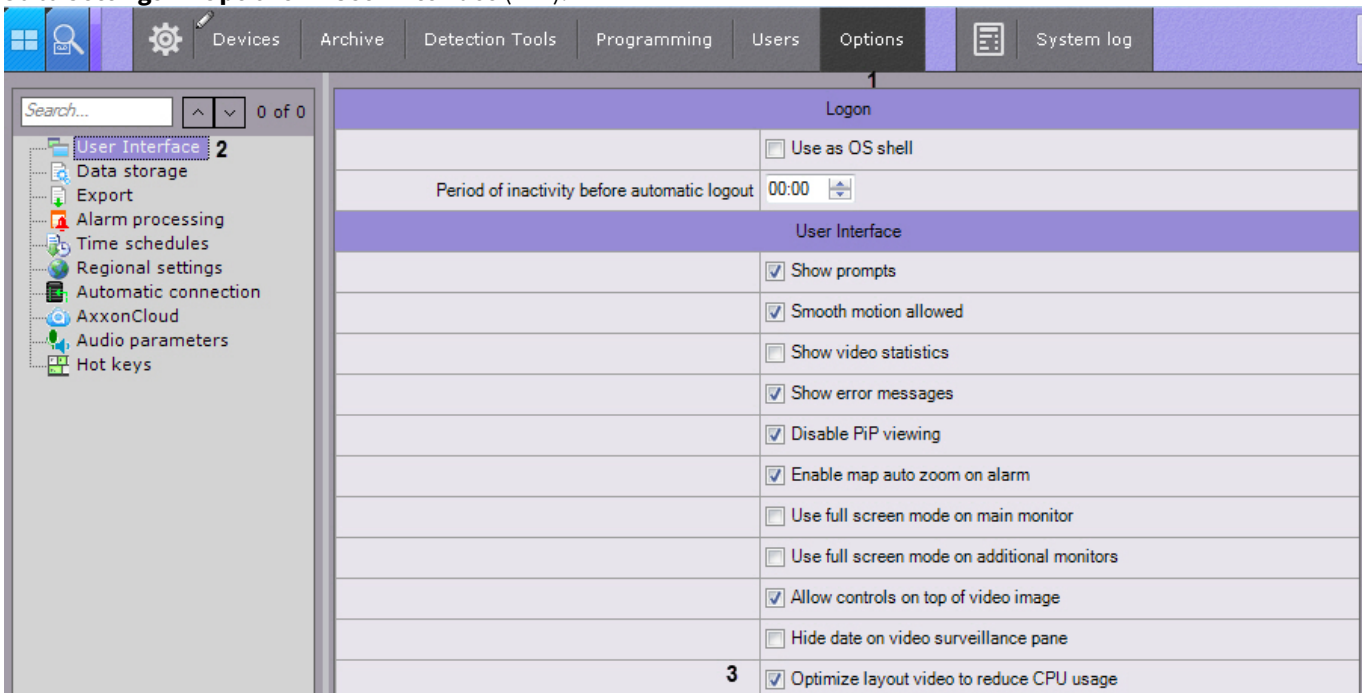

2. Uncheck the **Optimize layout video to reduce CPU usage** check box (3).
3. Click **Apply** to save the changes.

Note

When you enable the option, you may notice image quality drop.

7.10.2.1.14 Configuring tiles on the layout

By default, the size of tiles is proportional to the video resolution.

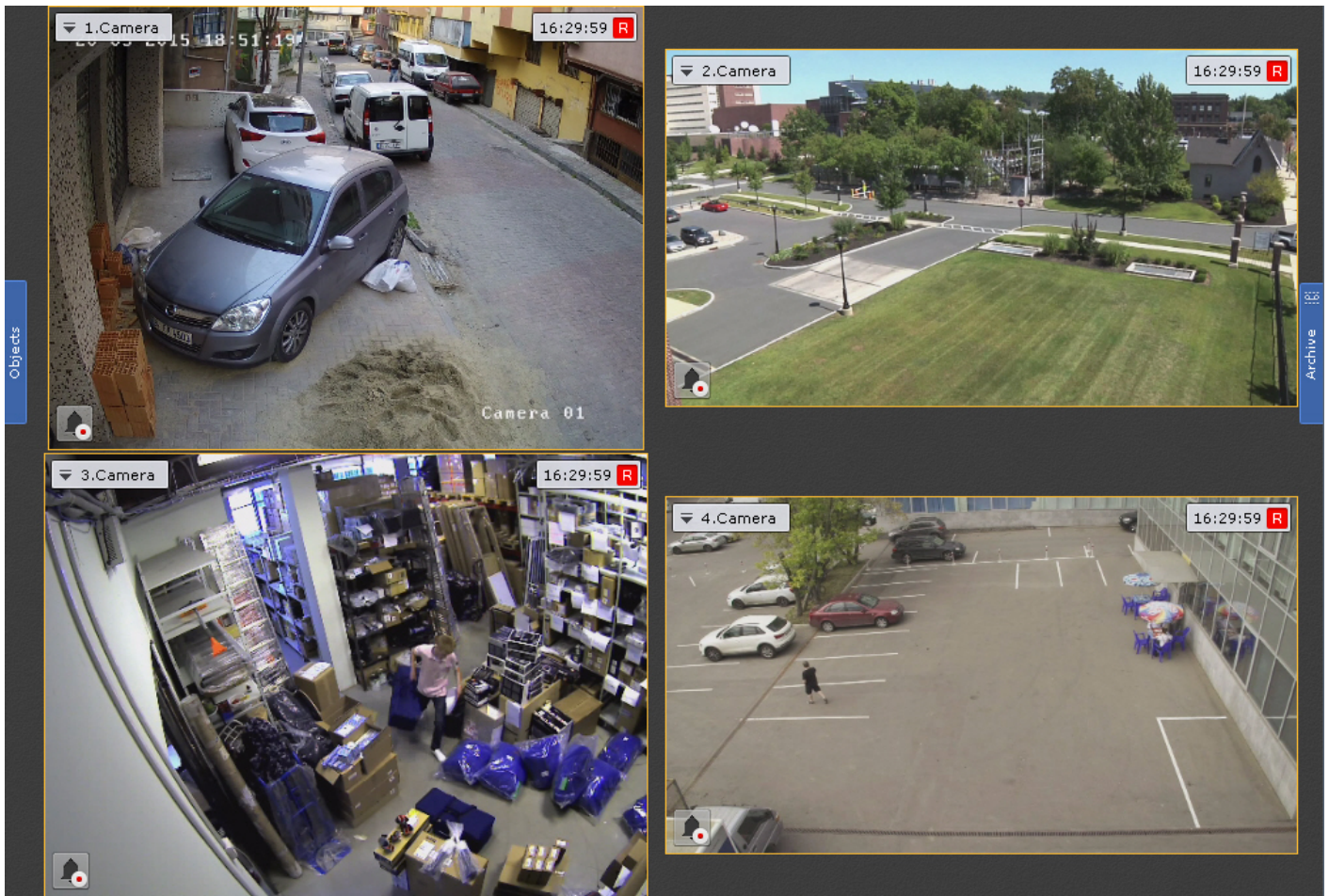

To fix the size and expand tiles to all free space on the layout area, do as follows:

1. Go to **Settings** → **Options** → **User interface (1-2)**.

- Uncheck the **Adjust video frame border** checkbox (3).

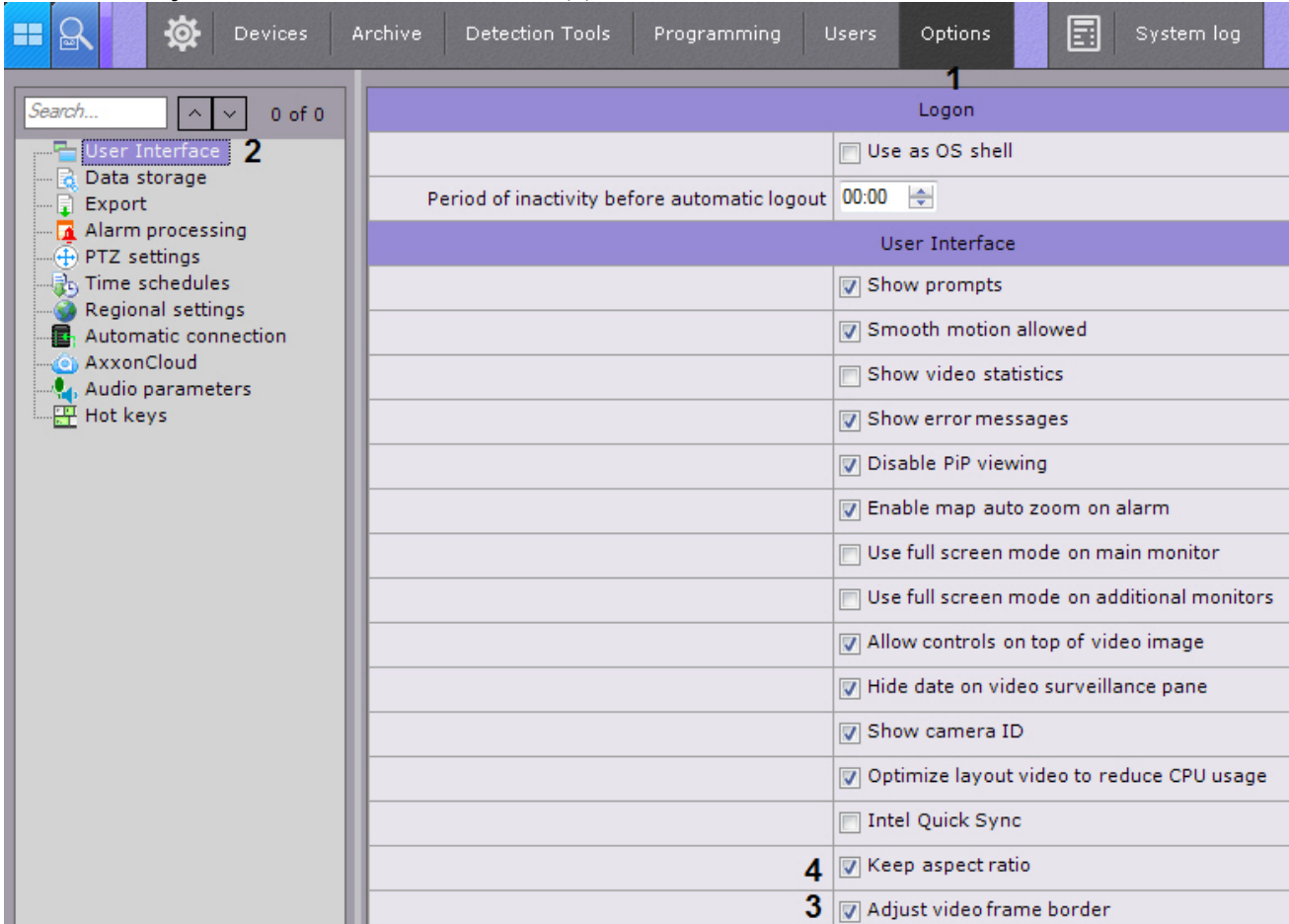

- Click **Apply** to save the changes.
- Reopen the Layout (see [Layouts Management](#)).

The video will retain its aspect ratio.

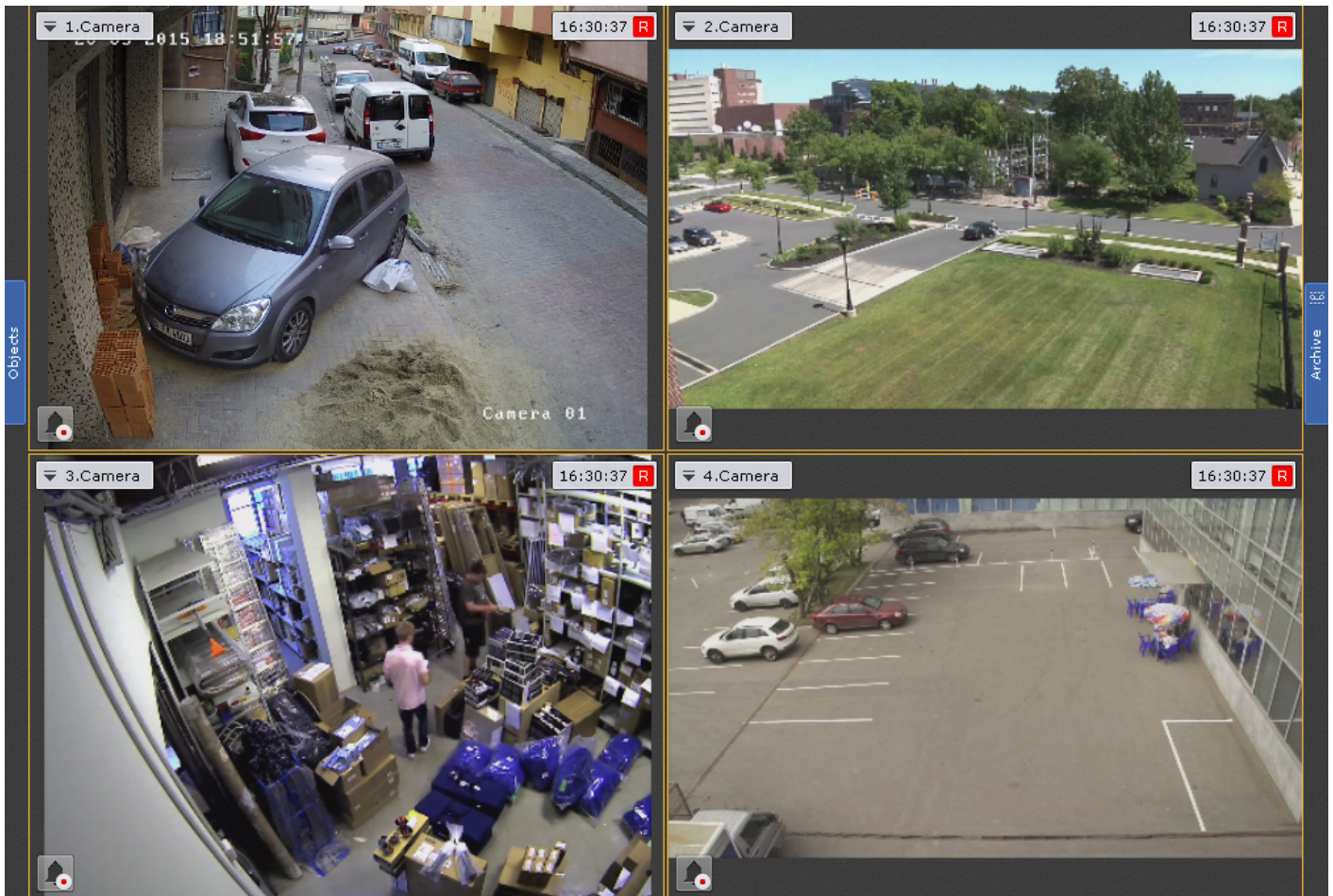

To expand video to all window, do as follows:

1. Uncheck the **Keep aspect ratio** checkbox (3).
2. Click **Apply** to save the changes.
3. Reopen the Layout (see [Layouts Management](#)).

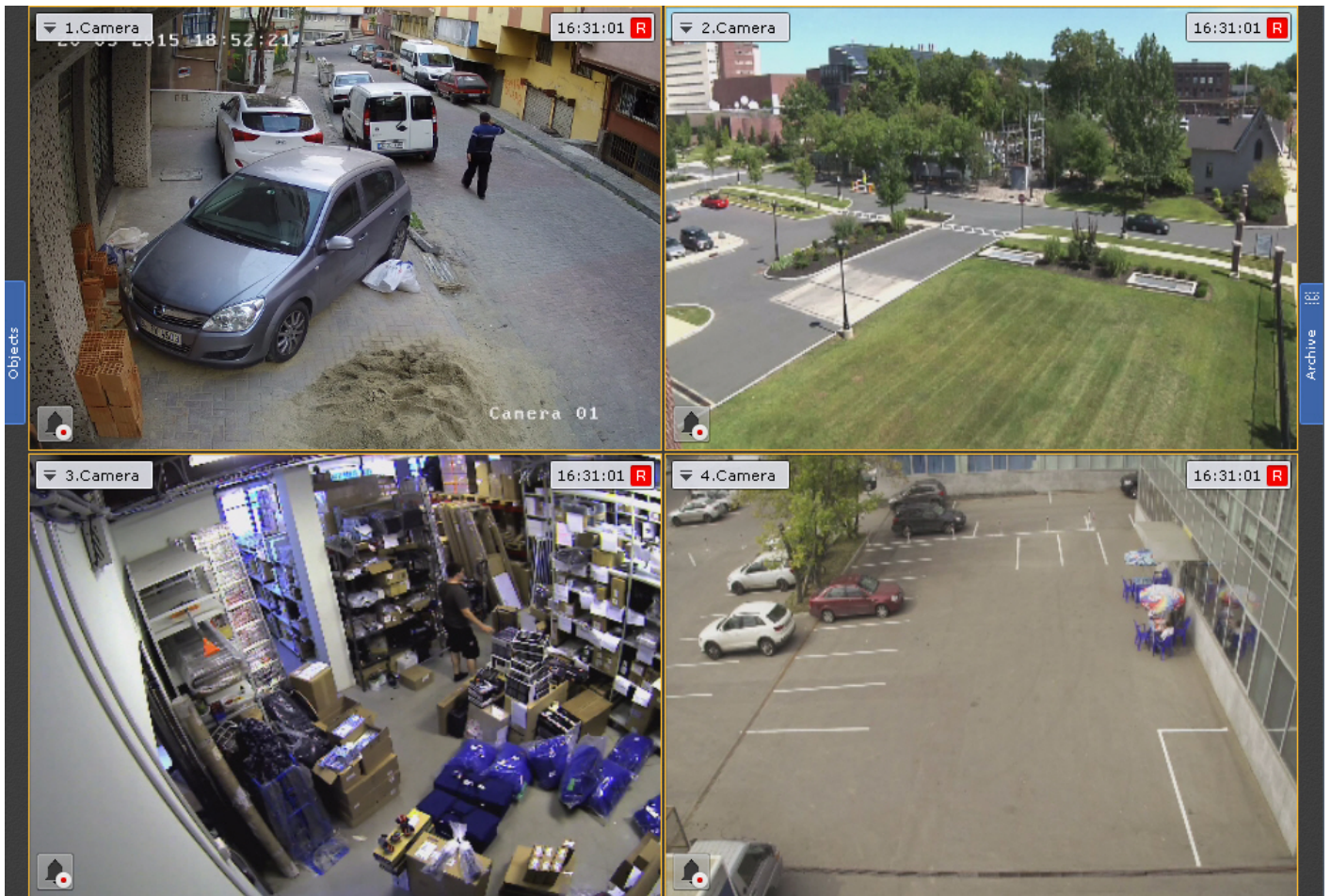

- Configuring Layouts
- Configuring viewing tiles

7.10.2.1.15 Configuring video display on the map

By default, the map shows video (see [Configuring a camera in standard map viewing mode](#)) only from cameras that are not on the current layout.

You can enable or disable video from all cameras on the map:

1. Go to **Settings** → **Options** → **User interface (1-2)**.

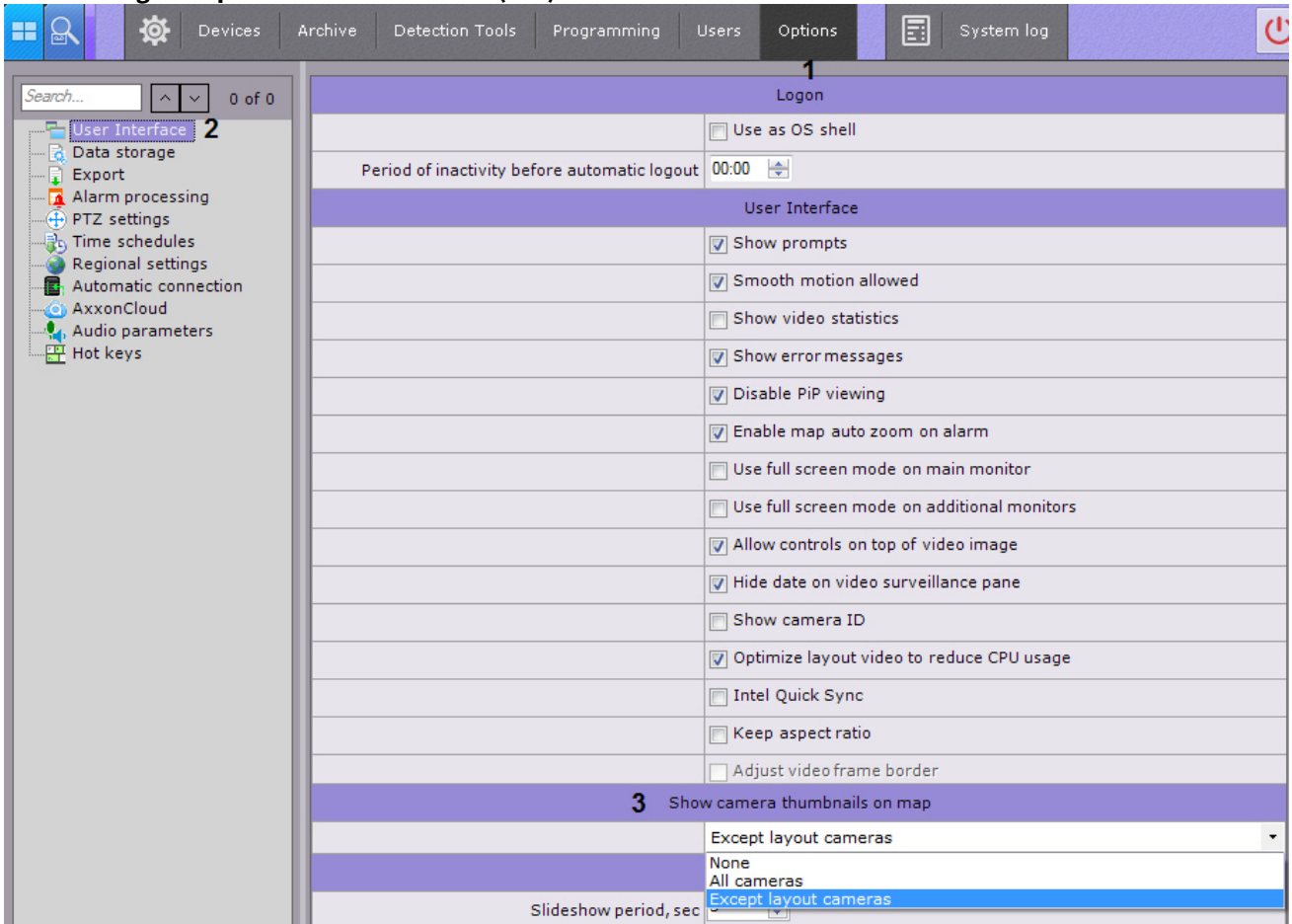

2. Choose video display mode on the map **(3)**.
3. Click **Apply** to save the changes.
4. Reopen the Layout (see [Layouts Management](#)).

7.10.2.1.16 Configuring camera sorting on Object Panel

By default, cameras on Object Panel (see [Objects Panel](#)) are sorted by short name (see [The Video Camera Object](#)).

To sort by full name, do as follows:

1. Go to **Settings** → **Options** → **User interface (1-2)**.

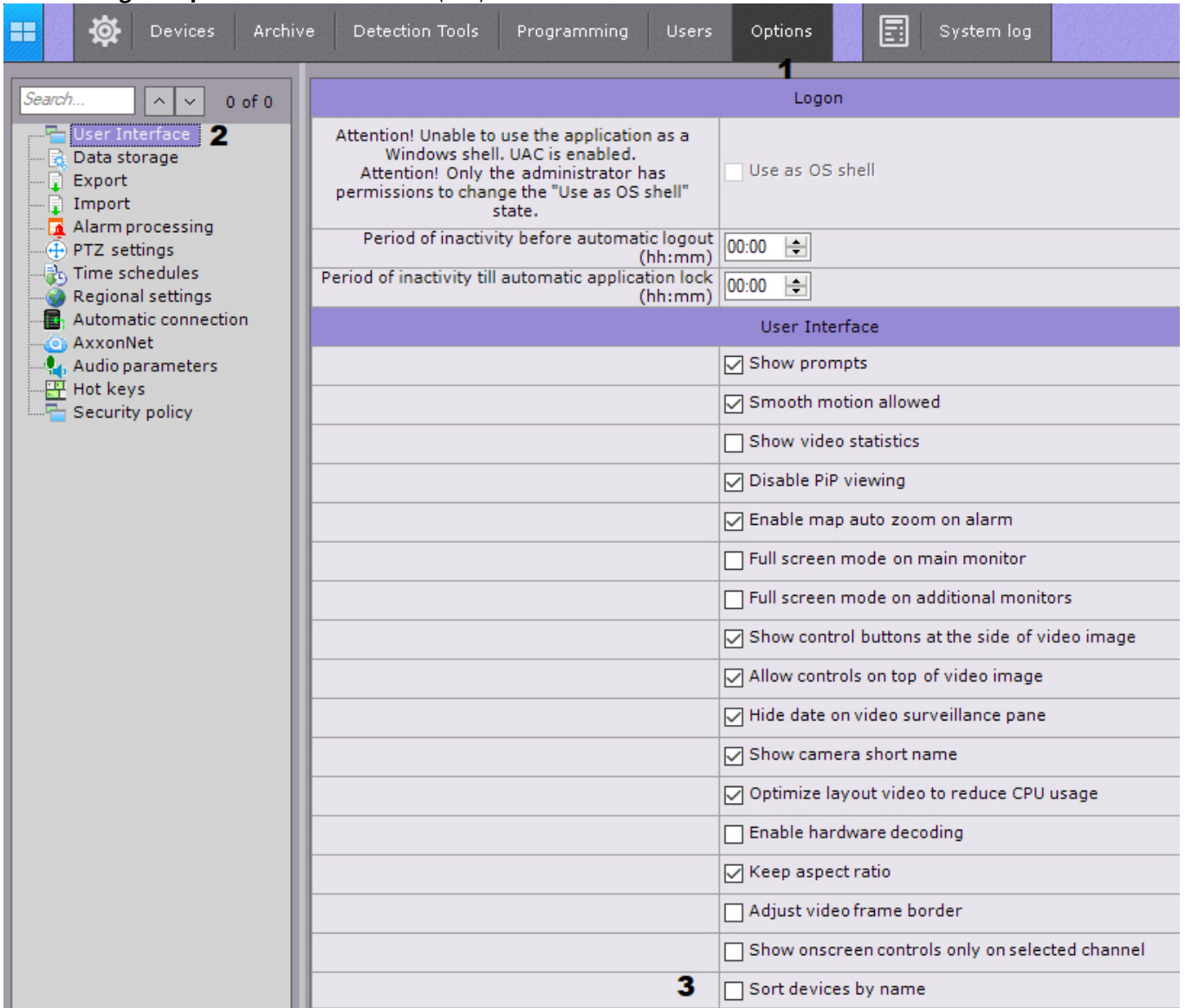

2. Select the checkbox **Sort devices by name (3)**.
3. Click **Apply**.

7.10.2.2 Configuring how Axxon Next starts

7.10.2.2.1 Configuring Axxon Next instead of the standard Windows OS shell

Autorun of Axxon Next, instead of the standard Windows OS shell, is used in cases where you need to restrict access to computers running the digital video surveillance system, including preventing the launch of various applications, file copying and deletion, various Windows operations, and other non-standard use of the computers.

If you configure *Axxon Next* to autorun instead of the standard Windows shell, *Axxon Next* will launch instead of Windows *Explorer* immediately after Windows loads. This makes it impossible for the user to launch certain applications installed on the computer or to work with certain program dialog boxes.

To activate autorun of the Axxon Next software package instead of the standard Windows shell, select the **Use as OS shell** checkbox in **Settings** → **Options** → **User interface** and click **Apply**.

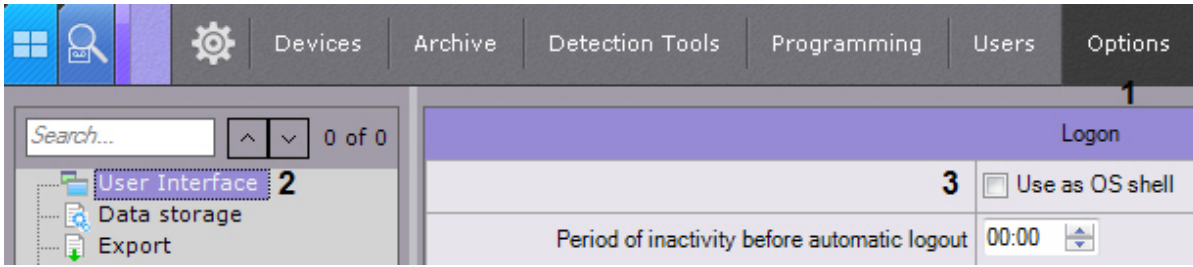

Axxon Next will now launch instead of the standard Windows shell the next time you start Windows.

Note

If User Accounts Control is enabled in the Windows OS, Axxon Next VMS cannot automatically start in place of OS shell (the appropriate check box is grayed out). Disable UAC. *In* Windows OS 8, 8.1 and 10 you also need to make changes to the [registry](#) and reboot your PC.

7.10.2.2.2 Configuring Cross-System Client and autologon

It is possible for the Client to automatically connect to Servers on different Axxon domains - [Cross-System Client](#).

For this to take place, the following conditions must be true:

- A paid license has been activated on each Server to which the Client is connected.
- Connection to all Servers made via with the same user name/password combination on each Axxon domain.
- Server names are unique.

Configuration of automatic connection to Servers on different Axxon domains is performed as follows:

1. Go to **Settings** → **Options** → **Automatic connection (1-2)**.

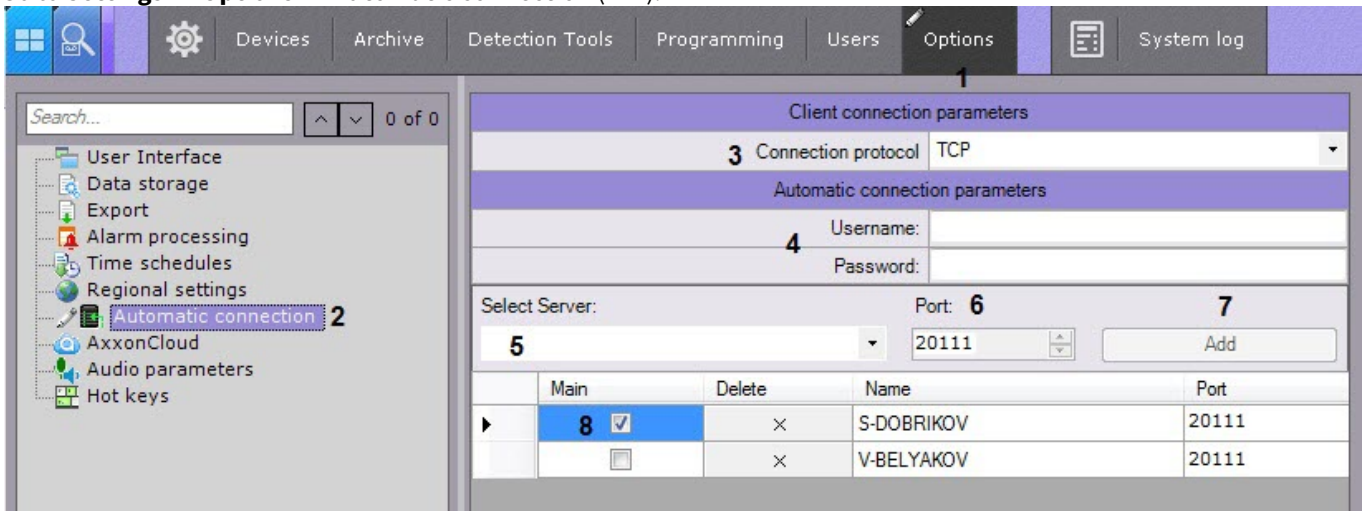

2. Configuring the protocol used by Clients to connect to the Server allows prioritizing reliability or speed of data transmission (3). The connection protocol is set individually for each Server in an Axxon-domain. All Clients connected to the Server will receive video streams over the selected protocol.

Descriptions and recommendations for selecting a protocol are given in the table.

Protocol	Description
TCP	This protocol is more reliable but bandwidth-intensive. Recommended for Servers with small numbers of cameras.
UDP unicast	UDP is typically faster but less reliable for data transmission. Unicast involves data transmission to a single recipient. This protocol is best for Servers with many cameras connected to a single Client.

Protocol	Description
UDP multicast	<p>Multicast refers to data transmission to a group of recipients. This protocol is designed for Servers with many cameras connected to multiple Clients.</p> <p>Important! This protocol has to be supported by all network components, in particular, switches.</p>

3. Type the user name and password needed for logging in to each Axxon domain (4).
4. Indicate the Servers to connect to. For each Server, perform the following steps:
 - a. Select the Server in the list (5).
 - b. Indicate the port for connecting to the Server (6).

Note

If the **Port** field is left blank, the standard port (20111) will be used for connecting

- c. Click the **Add** button (7).

Note

It is possible to connect to only one Server on an Axxon domain. So when a Server is added to the list, all other Servers on the Axxon domain become unavailable for selection

Note

To remove a Server from the list, click the  button

5. After all Servers have been added to the list, select the main Axxon domain.
When connecting, the Client will use the parameters (maps, layouts, user rights) of the main Axxon domain.
To select a main Axxon domain, select the check box in the relevant column of a Server that is on the Axxon domain (7).
6. Click the **Apply** button.

7. Click **Save (1)** to save the configuration of automatic server connection to the main Server.

Client connection parameters

Connection protocol: TCP

Automatic connection parameters

Username: root

Password: ••••

Discover cluster

Select server: Y-REZNIKOV
 Port: 20111
Add

	Delete	Main	Discover cluster	Name	Port
▶	×	<input checked="" type="checkbox"/>	<input type="checkbox"/>	A-KARPUKOV	20111
	×	<input type="checkbox"/>	<input type="checkbox"/>	V-BELIAKOV	20111
	×	<input type="checkbox"/>	<input type="checkbox"/>	Y-REZNIKOV	20111

2
1

Load
Save

8. To load the preset configuration to other Clients, do the following:
- a. Add the same main Server.
 - b. Click **Load (2)**.
 - c. Click **Apply**.

Note

You can also load a saved configuration after restoring the system using the appropriate utility (see [Backup and Restore Utility](#)).

Autoconnection to Servers on different Axxon domains is now complete.

The next time Axxon Next is started, connection to the selected Servers with the specified user credentials will occur automatically.

If a Client is connected to multiple Axxon domains, some of the settings on the **Options** tab (user interface, data storage, export, alarm management, and schedules) are duplicated for each Axxon domain; some are configured only for the main Axxon domain.

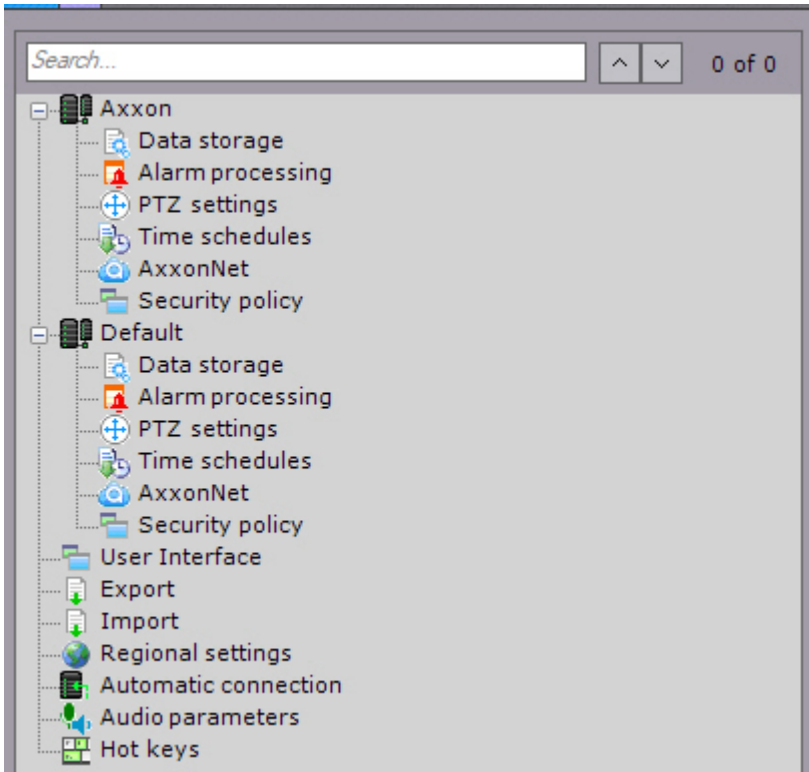

7.10.2.2.3 Configuring automatic exiting and locking of the Client

You can set the system to automatically exit and/or lock the Client if the user stays idle for a pre-determined time, i.e. no signals come from HID devices (keyboard, mouse, joystick, etc.).

To do so:

1. Go to **Settings** → **Options** → **User interface (1-2)**.

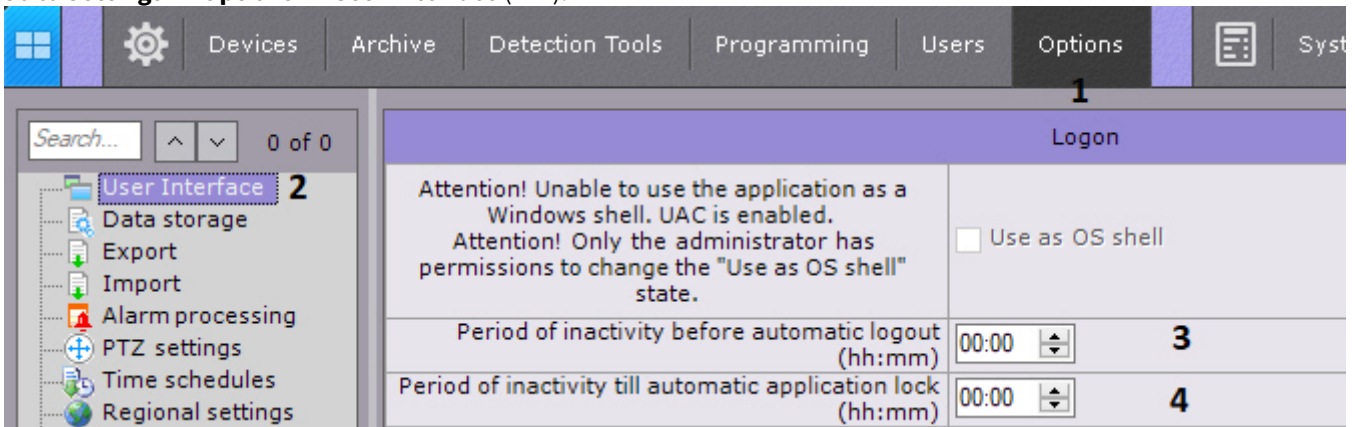

2. In the **Period of inactivity before automatic logout** field, enter the duration of user inactivity after which the Client should be quit (3).
If the field is blank or equals 00:00, the Client will not be quit.
3. Enter a value in the **Idle Time before Locking** field to set the time interval (4). To unlock the Client, the user has to re-login.
If the field is left blank or the value is set to 00:00, no locking will occur.

Note

If a viewing layout is open, no automatic blocking occurs.

Note

You can lock the Client at any time using hotkeys (see [Assigning hot keys, Appendix 6. Hotkeys in Axxon Next](#)).

4. Click the **Apply** button.

Configuration of automatic quit of the Client is now complete.

7.10.2.2.4 IP address filtering configuration

You can restrict remote clients' access to the server to a range of IP addresses.

To do this:

1. Select **Settings -> Options -> Security Policy (1-2)**.

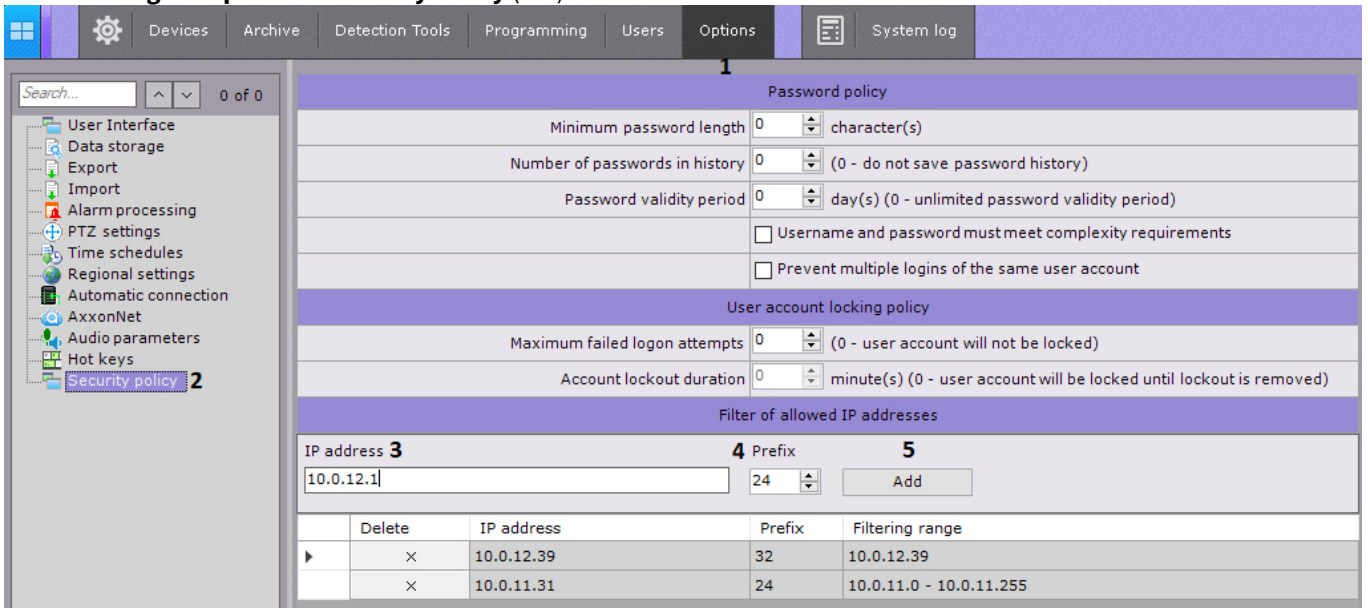

2. In the **Filter of allowed IP addresses** group, enter the IP address (3) and subnet mask (4) to set the range of addresses from which a connection will be permitted.
3. Click the **Add** button (5).
4. Click **Apply**.

The range is now added to the list. No connection will be possible from addresses not in the list.

To remove an address or a range from the list, do the following:

1. Click the  button.
2. Click **Apply**.

7.10.2.2.5 Selecting Preferred Servers

You can set Preferred Servers, which will be displayed at the top of the list when you launch Client (see [Starting an Axxon Next Client](#)).

To do it, follow the steps below:

1. Go to **Settings** → **Options** → **Automatic connection (1-2)**.

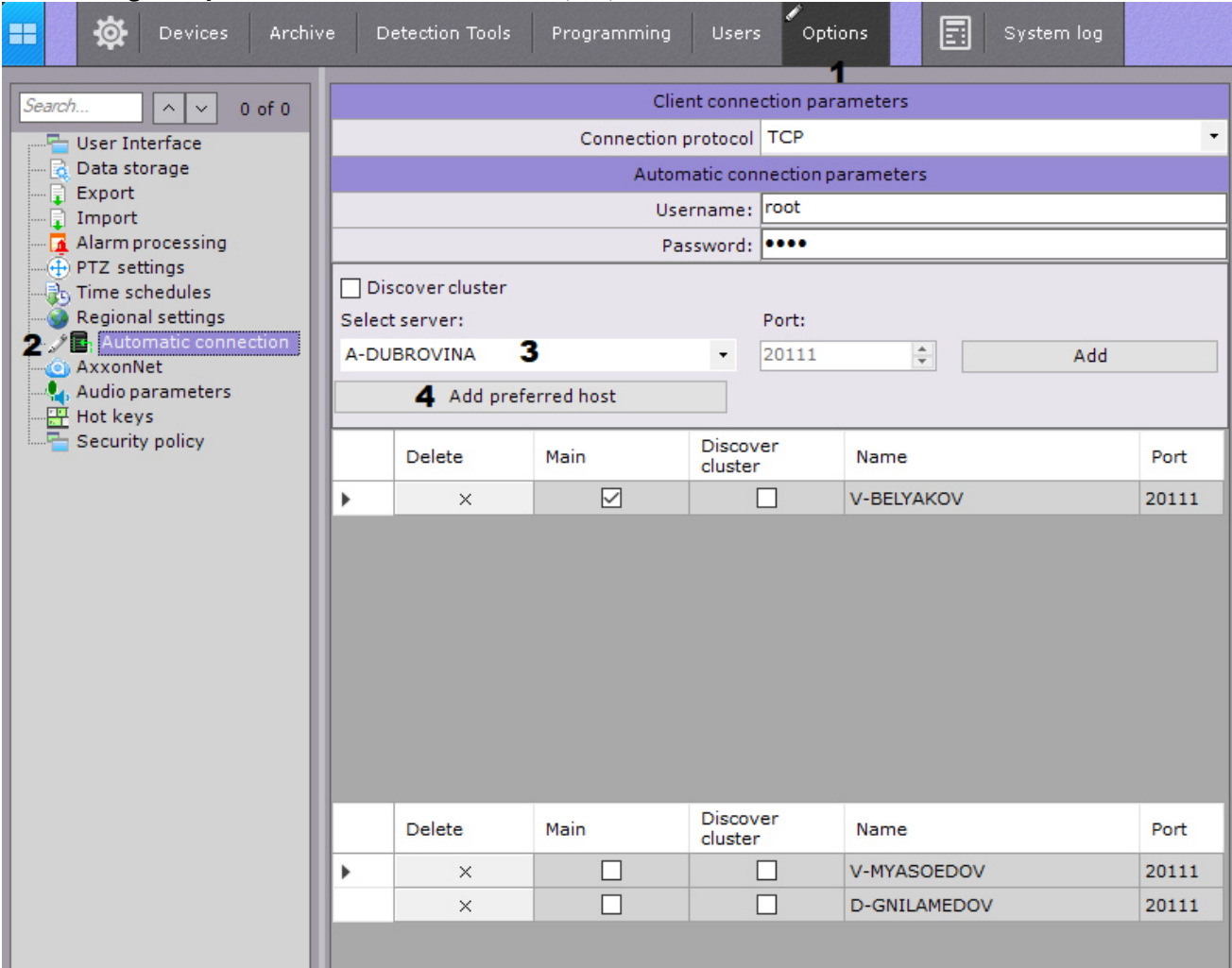

2. Select the Server in the list (3).
3. Click **Add Preferred Server** (4).
4. Repeat the steps for all target Servers.
5. Click **Apply**.

7.10.2.3 Configuring export

7.10.2.3.1 Configuring export options

Configuring export includes:

- Setting the default destination folders for exported files.
- Setting the default formats for export of video and snapshots.
- Configuring export of video in AVI format.
- Configuring the template for export of snapshots in PDF format.
- Other export settings.

Configure export as follows:

1. Go to **System settings** → **Options** → **Export (1-2)**.

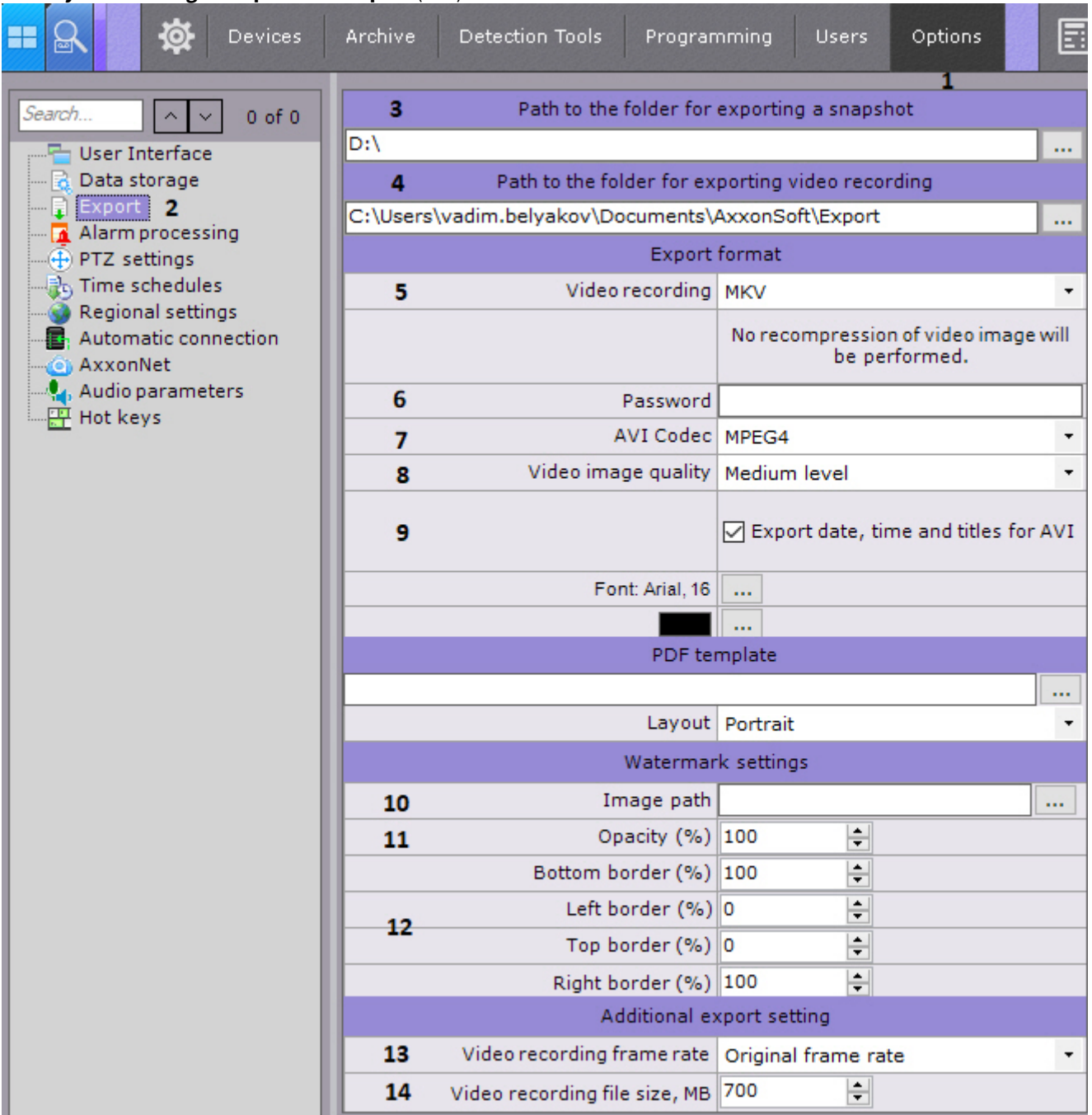

2. In the **Path to the folder for exporting a snapshot (3)** and **Path to the folder for exporting video recording (4)**, enter the full path to the folders where exported files are to be saved. To do this, click the button **...**.

Note

During export you can specify any path.

Note

By default, on Windows XP, exported files are stored in C:\Documents and Settings\User\My Documents\AxonSoft\Export\. On Windows 7 and Windows Vista, they are stored in C:\Users\User\Documents\AxonSoft\Export\.

Attention!

These fields also allow you to specify the name template for the exported files, as follows:



- {0}-Camera ID.
- {1}-Camera name
- {2}-Date.
- {3} Time.
- {4}-Recording duration (for video export only).

3. Select the default formats for export of video and snapshots (5). You can select any available format during export. Snapshots can be exported in two formats: JPG and PDF. Videos can be exported into the following 4 formats: MP4, MKV, EXE and AVI.

Note

Video is exported in MKV format without recompression.
 Video is exported in AVI format with recompression in the selected codec (see point 4).
 When video is exported in EXE format, a self-contained executable file is generated, containing video, playback tools, and necessary codecs.

4. If you want to export to an encrypted zip archive, set a password (6). If you are exporting an .exe file, you will need to enter a password when you open the file.
5. Specify settings for video export in AVI format: Select a codec (7) and compression quality (8).
6. If you want to superimpose captions in the exported video, select the **Export date, time, and AVI titles** check box. When exporting to MKV, captions are always added, you can turn them off when playing (9).
7. You can watermark exported video footage as follows:

Attention!

The watermark settings are applied to the entire Axxon domain.

- a. Select a file with a watermark (10). PNG, JPEG, BMP pictures are allowed.
- b. Set the transparency of the watermark: 100% - opaque, 0% - clear (11).
- c. Set the location of the watermark (12). To do this, specify the border of the watermarked area on each side of the frame as percentage of the frame size. The top left corner should be taken as the origin point.

The default values are:

Left	Top	Right	Bottom
0	0	100	100

the watermarked area will occupy the entire frame, and the watermark will be placed in the center of the image. To place the watermark in a corner, specify the following values:
 for the top-left corner:

Left 0	Top 0	Right watermark width as percentage of the frame width	Bottom watermark height as percentage of the frame height;
------------------	-----------------	--	--

for the bottom-left corner:

Left 0	Top 100 minus watermark height as percentage of the frame height	Right watermark width as percentage of the frame width	Bottom 100;
------------------	--	--	-----------------------

for the top-right corner:

Left 100 minus watermark width as percentage of the frame width	Top 0	Right 100	Bottom watermark height as percentage of the frame height;
---	-----------------	---------------------	--

for the bottom-right corner:

Left 100 minus watermark width as percentage of the frame width	Top 100 minus watermark height as percentage of the frame height	Right 100	Bottom 100
---	--	---------------------	----------------------

8. Select a frame rate for the exported video: if **Do not change** is selected, the original frame rate is kept; if **1/2** is selected, the exported frame rate will be two times smaller than the original one; if **1/4** is selected, four times smaller, and if **1/8** is selected, eight times smaller (**13**).

Note

The minimum frame rate of exported video is 1 fps.

9. Set the limit for an exported video file size in megabytes (**14**). If the exported video exceeds the specified size, multiple export files will be created.

Note

The minimum value is 5 megabytes.

Due to Windows limitations, you cannot export files of more than 4 Gb to EXE format.

Attention!

Zero value sets export to a single file irrelevant to its size.

10. Configure a template for export of snapshots in PDF format:

- a. Select the font and font color (**1**).
- b. If necessary, select the PNG image to use as the background of the PDF document (**2**).

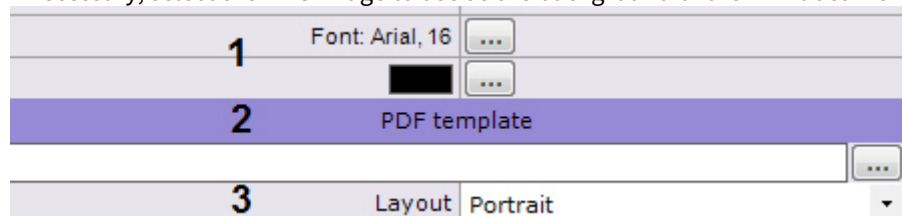

- c. Select the document orientation (**3**).
Exported PDFs consist of three sections: comment entered during export; date and time of the snapshot; and snapshot image.
- d. Configure the size of the sections and their position on the page.

The diagram shows a large rectangular window with a thin border. Inside the window, there are three smaller rectangular boxes stacked vertically. The top box is labeled 'Comment', the middle box is labeled 'Exported image', and the bottom box is labeled 'Date/time'. The boxes are light gray with thin black borders.

Note

Section sizes and positions can be changed like [standard windows](#).

11. Click the **Apply** button.

Export configuration is now complete.

7.10.2.3.2 Configuring an Export Agent

Export Agent is a service that allows automatically exporting snapshots and video to a particular Server when a defined system event occurs.

Automatic export of snapshots and videos will start when the relevant macro is run.

To create and configure an Export Agent:

1. In the device tree, select a server and click the **Create Export Agent** button.

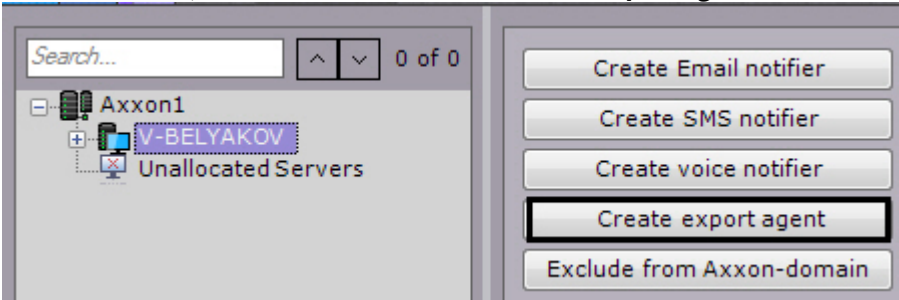

2. To enable the Export Agent, set **Enable** to **Yes (1)**.

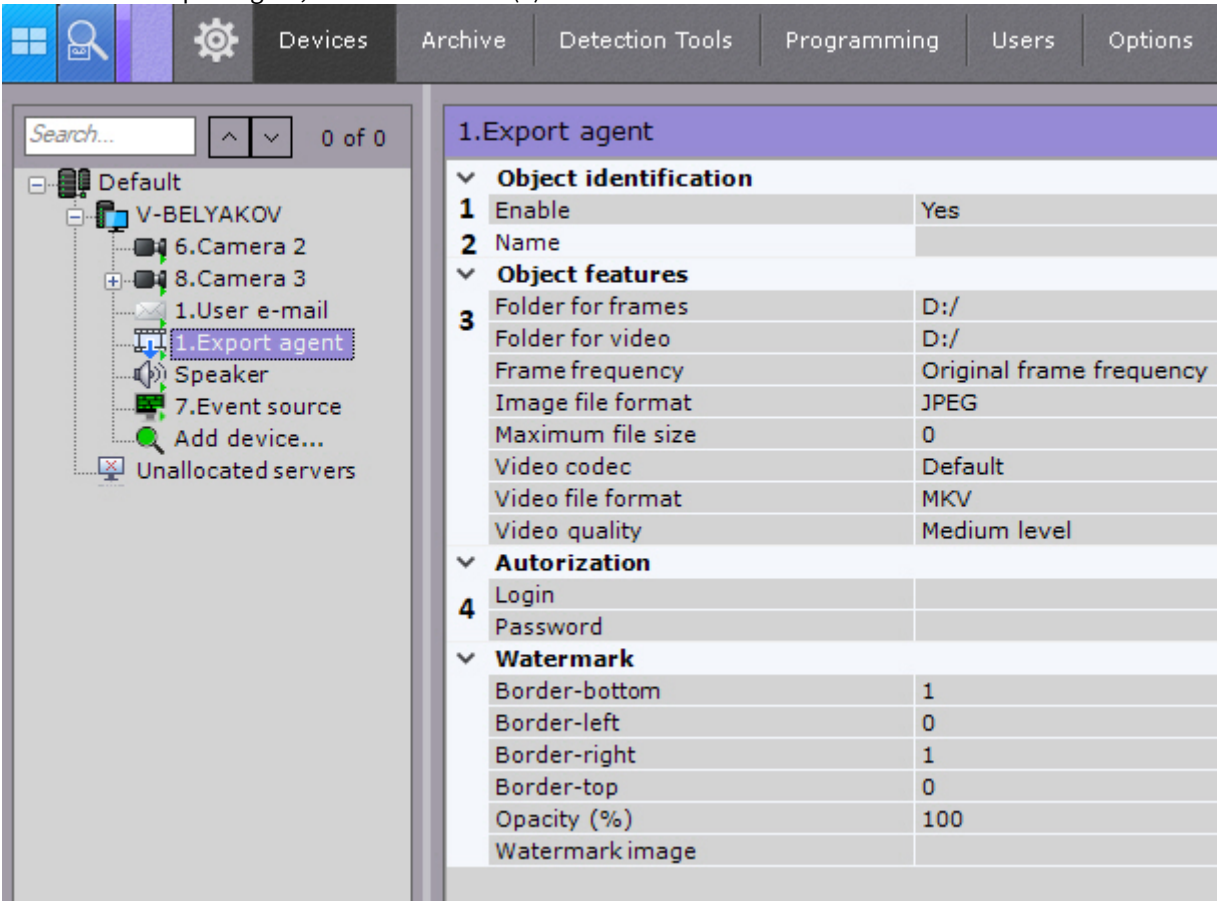

3. In the relevant field, set the object name (2).
4. Specify full paths to the folders that will store the exported snapshots and video (3). To do so, click the button in the relevant field. For network folders, enter the user name and password (4). The user must have permissions to access the NAS.
5. Specify other export options. See [Configuring export options](#) for more info
6. Click the **Apply** button.

Creation and configuration of the Export Agent are now complete.

7.10.2.4 Configuring audio on the Client

To broadcast audio from the Client microphone on a camera speaker, you must configure audio on the Client.

Do the following:

1. Go to **Settings -> Options -> Audio parameters (1-2)**.

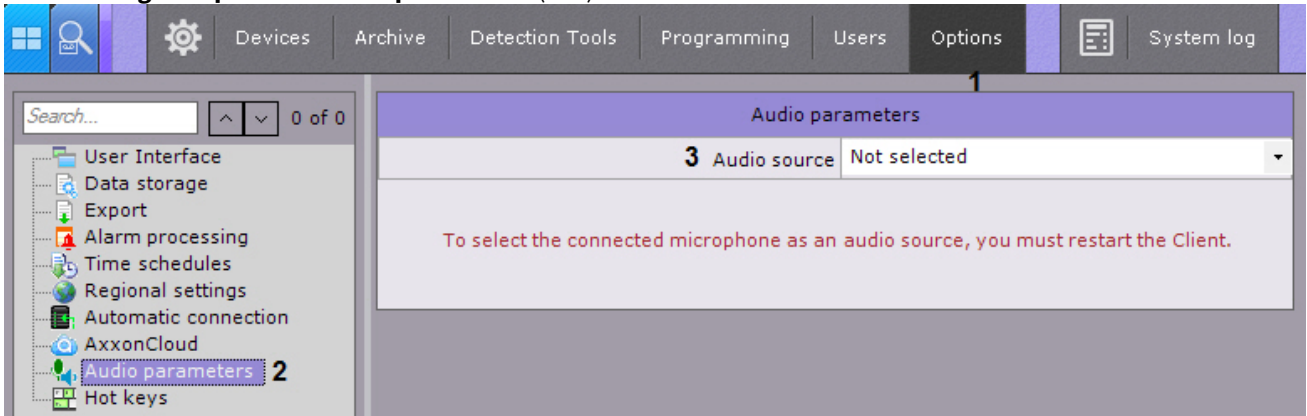

2. In the **Audio source** field, select the system device that will be used as the audio source for playback on the camera speaker (**3**).

Note

The default device is shown in the list in bold.

3. Click the **Apply** button.

Configuration of audio on the Client is now complete.

7.10.2.5 Configuring hot keys

7.10.2.5.1 Introduction to hot keys in Axxon Next

In Axxon Next, hot keys for standard keyboards and joysticks can be set to perform certain actions.

The operator's work with hotkeys is divided into 6 modes:

1. Global mode, in which a hot key is always available.
2. Live Video mode.
3. Archive viewing and search in archive mode.
4. TimeCompressor mode.
5. Alarm Processing mode.
6. Programming - running macros.

When setting hot keys, keep the following rules in mind:

- The same shortcut can be used for different actions in different modes.
- A shortcut in any particular mode can be associated with only one action.
- Shortcuts set in Global mode cannot be redefined in other modes.
- Hot keys are available only when the Client is active.
- On standard keyboards, alphanumeric keys must be preceded by modifier keys (CTRL, ALT, SHIFT).
- During system configuration (when the Settings tab is open), only one action with hot keys is available: go to layouts (the Activate panel of configuration command).

Note

Please refer to the list of hotkeys in [Appendix 6](#) to this guide.

7.10.2.5.2 Assigning hot keys

To assign hot keys:

1. Select the **Settings ->Options ->Hot keys** tab (1-2).

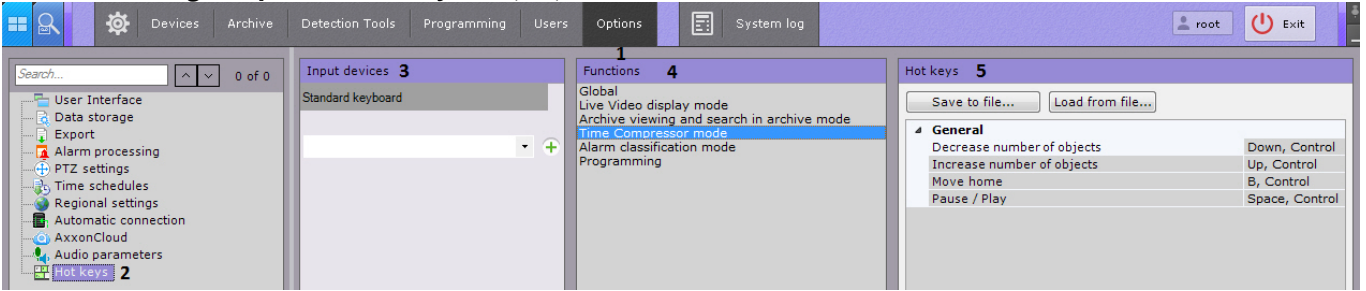

2. In the list, select the device for which you want to configure hot keys (3).
3. Select the mode for which you want to configure hot keys (4, see [Introduction to hot keys in Axxon Next](#)).
4. To assign a shortcut to a specific action:
 - a. Double-click the current shortcut assigned to the action (5). The field is now cleared.

Note

For some actions in Global mode, you cannot change the default hot keys.

- b. Press the key/key combination/joystick button to assign to the action.

Note

If the field is left empty, no hot key will be assigned to the action.

5. Assign hot keys for all actions of interest.
6. Click the **Apply** button.

Assignment of hot keys is now complete.

7.10.2.5.3 Exporting and importing hot keys

You can export and import hot key configuration files from and to the Client. Export and import of hot keys is performed via files in XML format.

To export hot keys:

1. Select the **Settings ->Options ->Hot keys** tab (1-2).

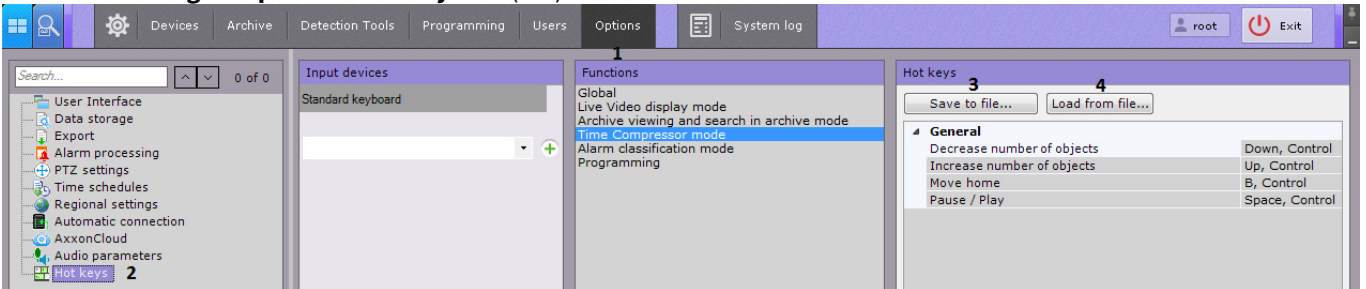

2. Click the **Save to file** button (3).
3. Select where to save the file and give it a name.

Export of hot keys is now complete.

To import hot keys:

1. Select the **Settings ->Options ->Hot keys** tab (1-2).
2. Click the **Load from file** button.
3. Select a file that contains a hot key configuration. Click the **Open** button.
The hot key combinations are imported into the Client, so long as a valid file is selected.
4. Click the **Apply** button.

Import of hot keys is now complete.

7.10.2.5.4 Notes regarding hot key actions

To select an active monitor in a multi-monitor configuration (see [Managing monitors on a local Client](#)), click **Select Monitor by number** (Global mode).

When you click the button or press the hotkeys, a window opens, where you can enter the monitor ID.

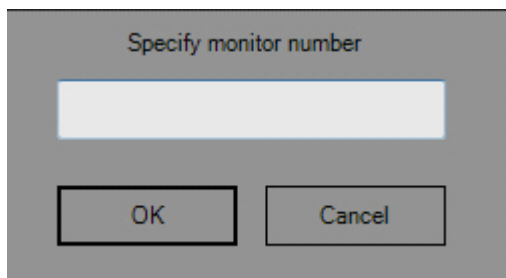

Enter the monitor ID and click **OK**. This monitor becomes active.

When a key or key combination assigned to the **Camera selection in current layout** action (Global mode) is pressed, the go to camera by ID window opens.

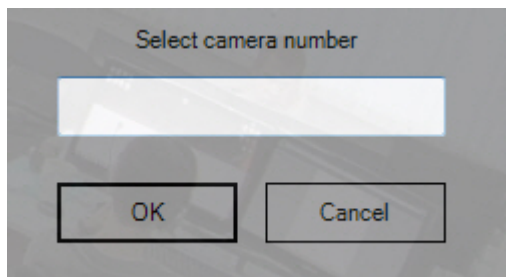

Enter the destination camera's user-friendly ID (see [The Video Camera Object](#)), then click **OK**.

If the current layout contains a camera with the specified ID, the relevant viewing tile becomes active. If the current layout does not contain a camera with the specified ID, a minimum layout containing the camera is opened.

If you press hotkeys for **Select layout by number** (Global mode), a window opens requesting you to enter the layout number. The layouts are sorted left to right, starting from 1.

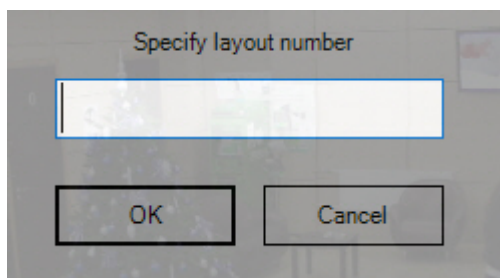

Enter the number of a desired layout, then click **OK**.

If you press hotkeys for **Select layout by ID** (Global mode), a window opens requesting you to enter the layout ID (see [Setting a layout ID](#)).

In all other cases, no system actions occur.

Descriptions of other non-trivial actions performed via hot keys are given in the table.

Mode	Action	Description
Global (general)	Navigation (up, left, down, right)	Navigate or move within the selected interface element. These keys are active only when a navigable menu or panel/ribbon is open.

	Activate layout ribbon	When this key is pressed, the layout ribbon expands, allowing to navigate between and select layouts. When the ribbon is minimized or a layout is selected, the relevant viewing tile becomes active.
	Activate panel of video walls	When this key is pressed, the panel of video walls expands, allowing to navigate between available monitors. When the panel is minimized, the viewing tile becomes active.
	Activate camera panel	When this key is pressed, the camera panel expands, allowing to navigate between and select cameras. When the panel is minimized or a camera is selected, a viewing tile becomes active.
	Activate panel of configuration	Pressing this key a second time opens the tools panel, on the Layouts ribbon.
	Open alarm panel	Pressing this key again minimizes the panel.
	Open panel with hardware list (left)	Pressing this key again minimizes the panel.
Global (map)	Switch to 3D mode	If the map is in 2D mode, clicking this button switches to 3D mode. If the map is in 3D mode, clicking this button hides the map.
Live Video mode	Open the menu of the selected camera and select a menu item.	Pressing this key again closes the menu.
	Switch to Archive mode	If a viewing tile in a layout is active, the archive is opened only for that particular camera. Pressing this key again switches to Live Video mode. If there are no active viewing tiles in the layout, the archive is opened for all cameras in the layout.
Archive viewing and search in archive mode	Go to Search in Archive mode.	Pressing this key again switches to Archive mode.
	Go to the next/previous frame	Holding this key moves forward/backward frame by frame until the key is released.
	Go to the next/previous video clip	Holding this key moves forward/backward between video clips until the key is released
	Go to TimeCompressor mode	Pressing this key again switches to standard archive mode.
	Open list of timeline events	Pressing this key again closes the list.
	Move to next hour Move to next month Move to next timestamp Move to previous hour Move to previous month Move to previous timestamp	Listed are the actions available while operating the Calendar (see Navigating Using the Timeline).

7.10.2.5.5 Joystick Configuration

To configure the joystick, do as follows:

1. Connect the joystick to a computer.
2. Calibrate the joystick.
3. Select the joystick from the list and click the button .

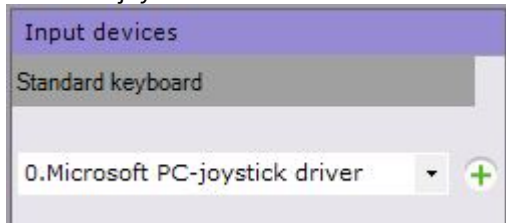

4. Set keyboard shortcuts, and click **Apply**.
5. Configure the sensitivity for PTZ controls:
 - a. Start a text processor (i.e. Notepad) and open the file <Joystick_Name> .xml, which is located in C: \Users\<User_Name>\AppData\Local\AxxonSoft\AxxonNext\HotKeysXmlConfigurationFiles.
 - b. Set the sensitivity for commands in **<Sensitivity>0.2</Sensitivity>**.

```
<HotKeysSchemaDeviceCommands>
<CommandName>DiscreteZoomOut</CommandName>
<HotKey>A2-</HotKey>
<Sensitivity>0.2</Sensitivity>
</HotKeysSchemaDeviceCommands>
```

The sensitivity values range from 0.0 (low sensitivity) to 1.0 (high sensitivity). Please see the commands that have sensitivity settings in the table.

Command	Command description
DiscreteMoveXAxisRight	Pan right (Move right)
DiscreteMoveXAxisLeft	Pan left (Move left)
DiscreteMoveYAxisUp	Tilt up (Move up)
DiscreteMoveYAxisDown	Tilt down (Move down)
DiscreteZoomIn	Zoom in
DiscreteZoomOut	Zoom out
DiscreteFocusNear	Reduce the focal length
DiscreteFocusFar	Increase the focal length
DiscreteIrisOpen	Open the iris
DiscreteIrisClose	Close the iris

Attention!

Do not set values outside the range and edit other parameters in the file.

- c. Save the changes to the file.

Joystick configuration is now complete.

If the joystick is already configured the specified file does not have the **Sensitivity** parameter, do as follows:

1. Remove / Delete the joystick from the *Axxon Next VMS*.



2. Click the **Apply** button.
3. Add and configure the joystick again.

7.10.2.6 Configuring video capturing on operator monitor

Record of video from computer monitor is performed to control operator actions. Video from computer monitor can be transmitted to the Axxon Next software package by general protocols using external programs, for example:

1. By RTSP protocol using the VLC Media Player included into the software package.
2. By ONVIF protocol using the ScreenOnvif program which can be got in the <http://screenonvif.com/en> web-site.

Example of the VLC Media Player configuring for transmitting video from computer monitor to the *Axxon Next* by the RTSP protocol is presented in this section. Configuring of the Axxon Next software package to receive and record this video stream is performed by standard means as described in the [Configuring an RTSP Server](#) and [Binding a camera to an archive](#) sections.

Configuring the VLC Media Player for transmitting video from computer monitor to the Axxon Next software package by the RTSP protocol is performed the following way:

1. Run the VLC Media Player.
2. Select the **Open Network Stream item...** in the **Media** menu.

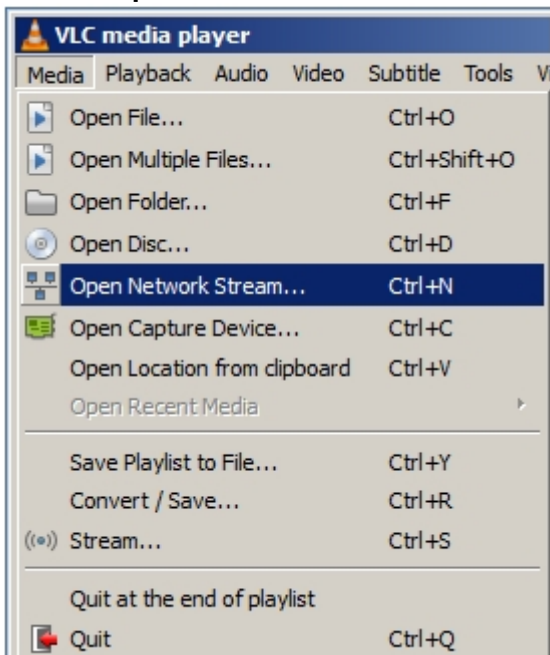

- In the opened window go to the **Capture Device** tab.

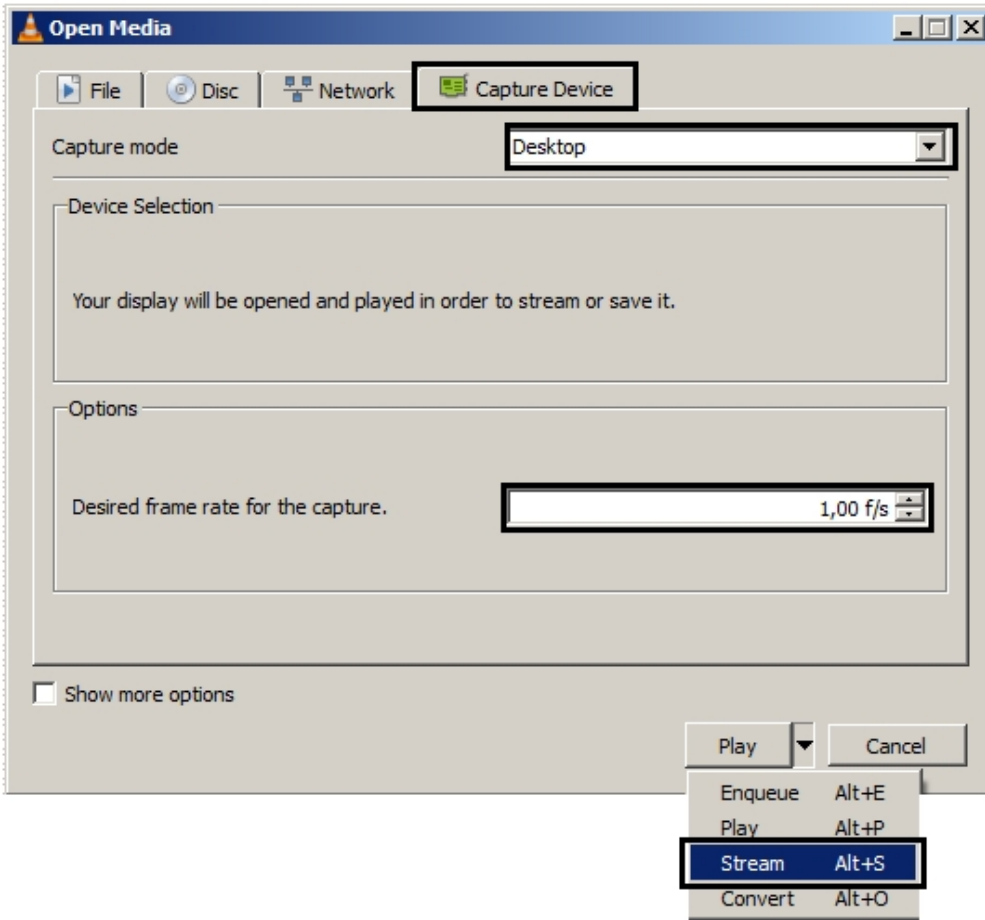

- In the **Capture mode** drop-down list select the **Desktop** value.
- Set the desired frame rate for the capture in the corresponding field.
- In the **Play** list select the **Stream** value. As a result the **Stream Output** window will open.

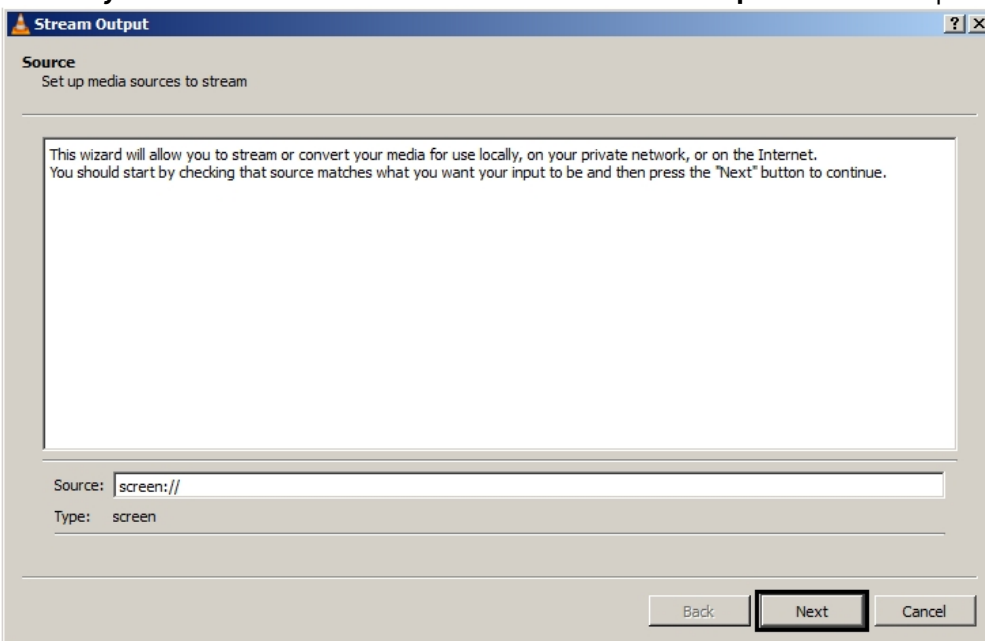

- Click the **Next** button.

- 8. In the opened window select the **RTSP** value in the **New destination** drop-down list and click **Add** button.

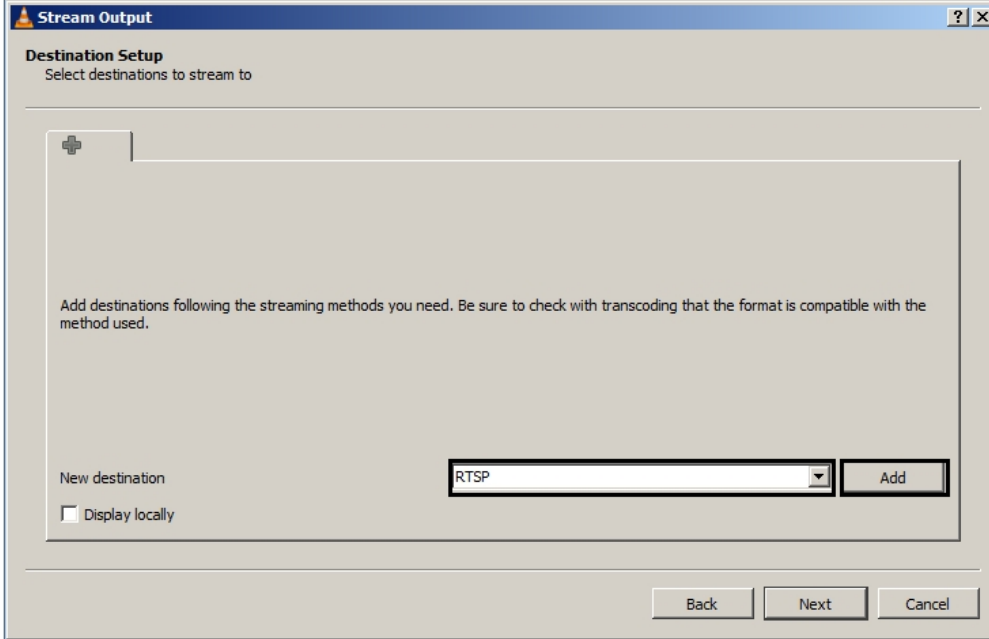

- 9. Go to the **RTSP** tab.
- 10. Specify port and path to the stream if it's required.

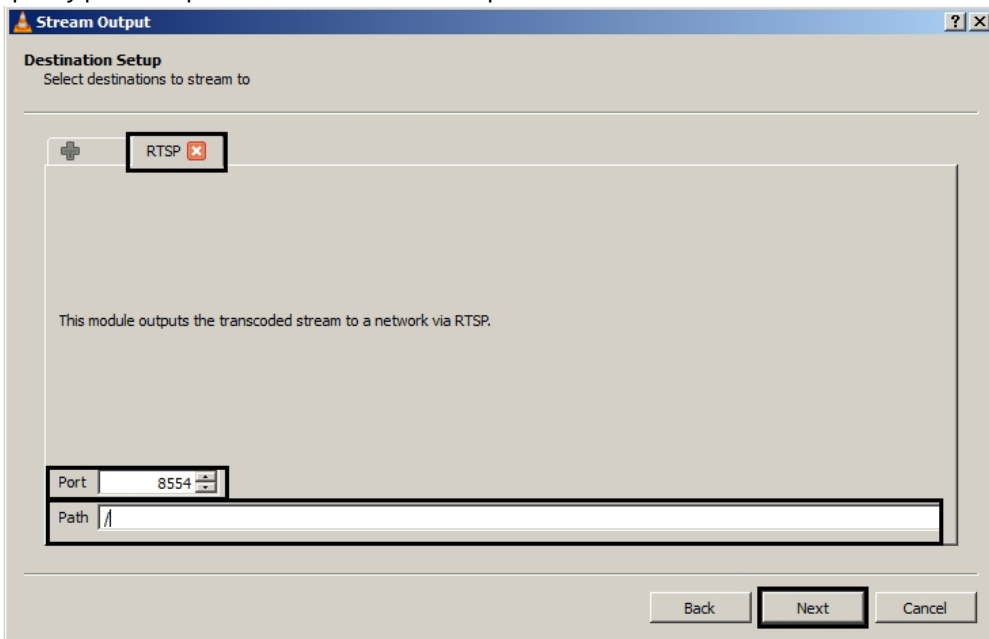

- 11. Click **Next** button.

12. Specify parameters of video transcoding and click **Next** button.

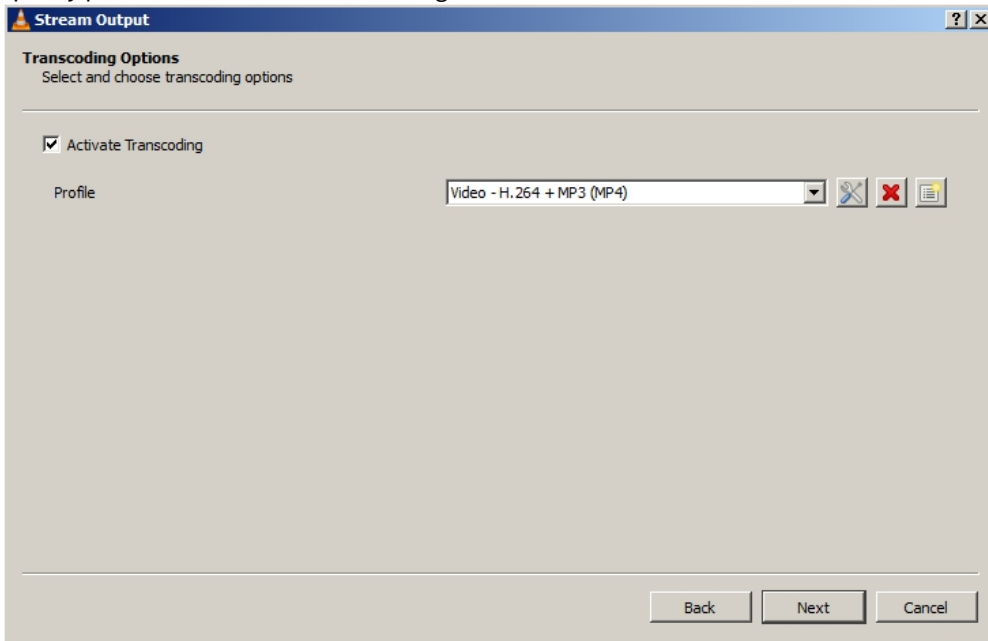

13. Click **Stream** button in the opened window.

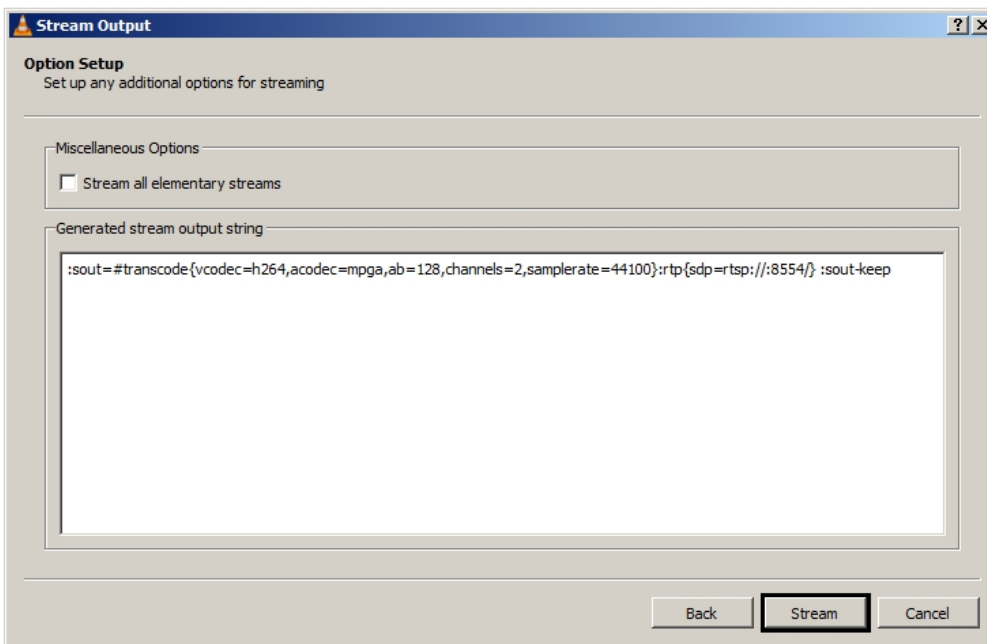

After that configure receiving of the RTSP stream and its record to the archive in the Axxon Next software package – see [Configuring connection of video cameras via RTSP](#) and [Binding a camera to an archive](#) sections.

Configuring of the VLC Media Player for transmitting video from computer monitor by the RTSP protocol to the Axxon Next software package is completed.

7.11 Configuring Failover VMS

7.11.1 General information about a failover system

A failover system automatically prevents data loss when one of the servers in the system fails.

In a failover system, the servers are combined into a logical structure - the cluster.

The Axxon Next Failover system has two types of configuration.

1. The basic configuration allows system supervisors to permit launching Axxon Next servers (nodes) on any Servers within the system.

Note

While selecting a Server to transfer a node to, the supervisor tries to keep in balance the whole cluster's performance. If all Servers deliver more or less the same performance, the selection is performed randomly.

If Servers significantly differ in their performance, the supervisor may launch several nodes on a more capable Server, and no nodes on a less capable one.

2. In the configuration with the specified backup Server, a node from the primary Server can be migrated only to the backup Server. After the primary Server is back online, the node is returned.

Node migration is automatic and takes no more than one minute.

Note

In a system counting 100 cameras, the node is transferred in less than one minute in both Failover System configuration types. All Servers within the system have identical specifications: Intel i5-7400 3GHz 4-core CPU, 16Gb RAM.

This section contains the following terms:

- **Server** -a computer with **Failover Server and Client** configuration of Axxon Next installed.
- **Node**- an instance of the Server services. A Server can have multiple nodes running.
- **Cluster**- logical grouping of Servers that allows migration of clusters between them. A cluster may encompass nodes from different Axxon domains.
- **Supervisor**- the service that monitors the status of nodes and their migration.

To implement Failover in your system, we strongly recommend that:

- The system administrator should have full control over all communication channels and hardware that provides fault tolerance at all times.
- You should build a cluster from servers in the same LAN.
- Use only the network archives, that are available from all servers in the cluster.

Example:

CLUSTER

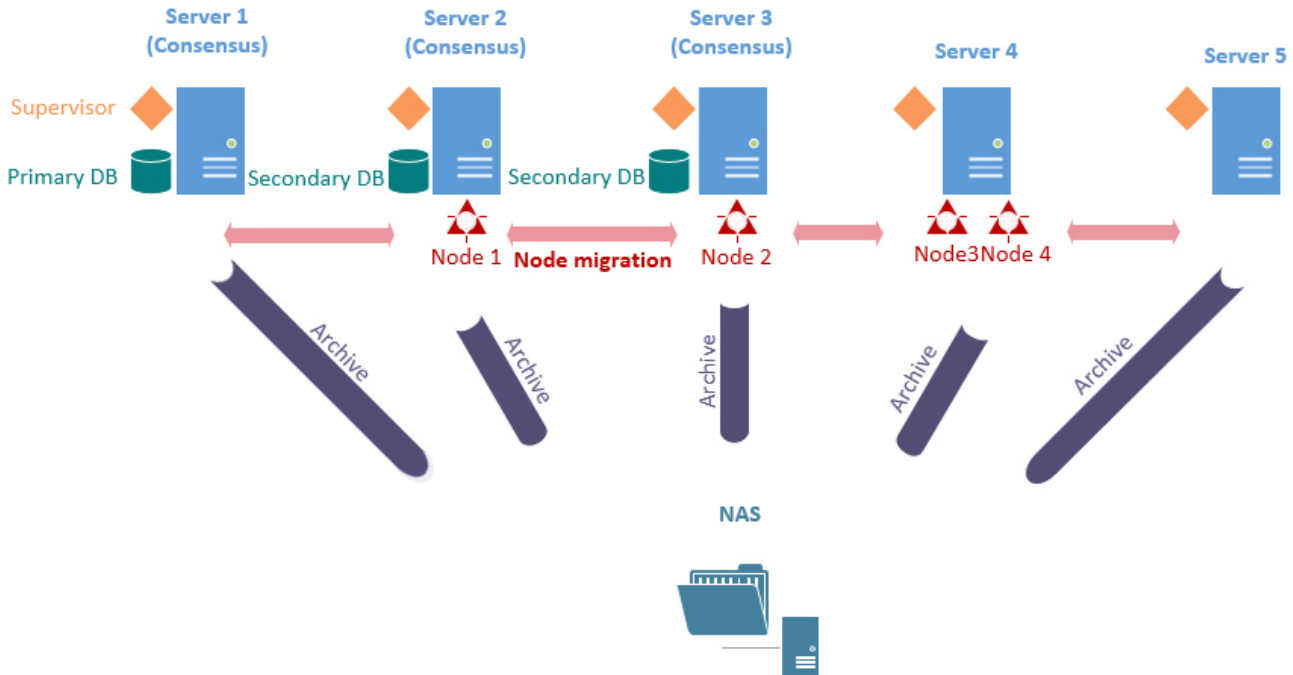

7.11.2 Ports used by the failover system

Each failover system server uses the following ports:

- 4000 (Supervisor Web Interface, only TCP).
- 4646 (Nomad HTTP API, only TCP).
- 4647 (Nomad RPC, only TCP).
- 4648 (Nomad LAN/WAN Serf (Gossip), TCP and UDP).
- 8300 (Consul Server RPC, only TCP).
- 8301 (Consul LAN Serf (Gossip), TCP and UDP).
- 8302 (Consul WAN Serf (Gossip), TCP and UDP).
- 8500 (Consul HTTP API, only TCP).
- 8600 (Consul DNS, TCP and UDP).

Moreover, each node of the cluster has its pre-defined unique port range (see [Installation](#)). For best results, use port numbers from 20111 to 32000.

7.11.3 Supervisor Web Interface

You can configure a failover system in the Supervisor Web interface at <http://localhost:4000>.

Note

After installation, a shortcut is added to your desktop.



On Linux OS, no additional shortcuts are created after installation. To access the supervisor web interface, go to <http://localhost:4000>.

The Supervisor Web interface has 4 tabs:

1. **Hosts** - Creating a Cluster.
2. **Configuration** - Failover Database, Configure a Failover System Cluster.
3. **Dashboard** - Cluster Monitoring.
4. **Users** - Set up access to a supervisor.

To find out your version of *Axxon Next* and *Driverpack*, click **Software version**.

To search hosts and servers, enter their names in the search bar in the **Host** tab or **Dashboard** tabs at the top of the window.

7.11.4 Creating a Cluster

The first time you launch the Supervisor, you should initialize the cluster. To do this:

1. Select the Server's IP address from the list and click **Next**.

1 Set server address — 2 Link other servers — 3 Bootstrap

Choose a network interface to use as a server

169.254.79.183

10.0.11.66

169.254.209.103

169.254.62.115

NEXT

2. Add the required Servers to the cluster. To do this, enter the IP address and click **Link**.

✓ Set server address — 2 Link other servers — 3 Bootstrap

Link other servers to cluster

IP address

10.0.11.10 LINK

BACK NEXT

Attention!

All Cluster servers must be accessible to each other.

All servers must be hosted on computers with the same architecture (x 86, x 64).

Attention!

The first three Servers added become the master Servers.

The operation of the cluster is coordinated by its master Servers, which, in particular, take decisions to migrate nodes from one Server to another.

You can have 3 or master servers in the cluster.

If only two Servers are added, they can be configured as **1+1** (primary + backup Server).

3. If required, you can add a user with administrator rights. After the cluster is created, only this user will have access to the supervisor. Please follow the steps below:

- a. Click the **Add** button.

Progress: ✓ Set server address — ✓ Link other servers — 3 Create user — 4 Bootstrap

Create a user with administrator privileges

i Add username and password and click next

Login
root

Password
●●●●

BACK CANCEL NEXT

- b. Enter access credentials and click the **Next** button.

4. After you added all servers, click the **Initialize** button.

Progress: ✓ Set server address — ✓ Link other servers — ✓ Create user — 4 Bootstrap

Confirm creating configuration Pool

- 10.0.11.66
- 10.0.11.103
- 10.0.11.102

BACK INITIALIZE

This will initialize the cluster based on the selected Servers. To add more Servers to the cluster, do the following:

1. On the **Hosts** tab, click .

2. Enter the IP address of the server (1).

3. If the server you are adding is master, select the **Manager** checkbox (2).
4. Click **Add Host** (3).
5. Add all required Servers.

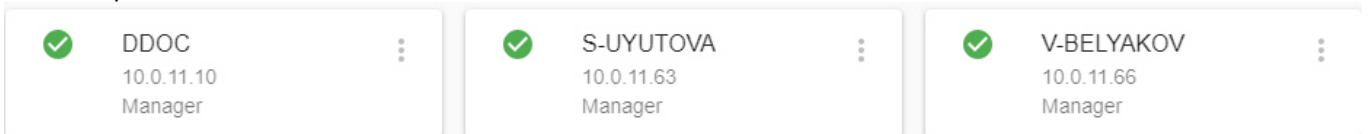

Note

To remove a server from the cluster, click  and then Remove.

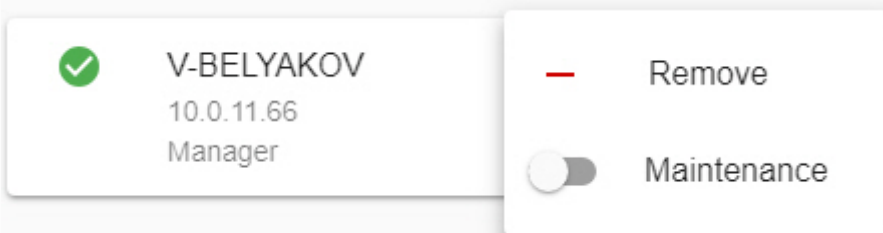

Attention!

To change the IP addresses of the server in the cluster, do as follows:

1. Remove the server from the cluster.
2. Change the IP address of the server.
3. Add the server with a new IP address.

7.11.5 Failover Database

By default, the database is created automatically when the cluster is initialized, and its agents are launched on the master Servers.

The database is located in the C:\pgdata folder and uses port 49998.

To manage database agents, do the following:

1. Go to the **Configuration** tab.

2. Click **DB Agents**.

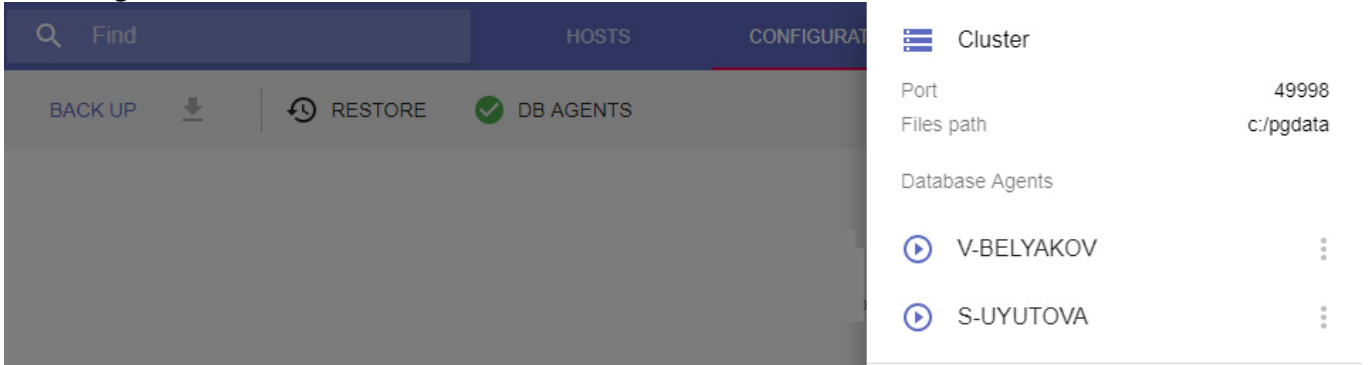

3. The icon next to the Server indicates the current status of the agent.

Icon	Status
	Launch expected
	Launched
	Stopped

4. Click to stop or launch the agent, and select the required action.



7.11.6 Configure a Failover System Cluster

A failover system can be configured two ways:

1. Basic configuration. There are no pre-assigned backup Servers in this configuration. The supervisor independently decides where to host a particular node. Only network archives can be used in this configuration.
2. Configuration with the specified backup Server. In this configuration, a backup server is assigned to host a node which for some reason cannot operate on its primary server. Along with network archives, local archives can be used in this configuration.

In addition, you can create independent nodes.

7.11.6.1 Setting up basic configuration

To set up a basic configuration of a Failover system, do the following:

1. Go to the **Configuration** tab.

2. Hover the mouse cursor over the  button and click the **N+M** button.

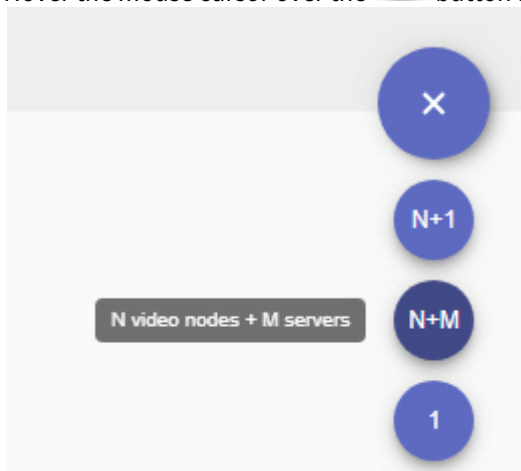

3. Add Servers to the configuration.

- a. Click .
- b. Select a specific Server, or add all Servers at once.

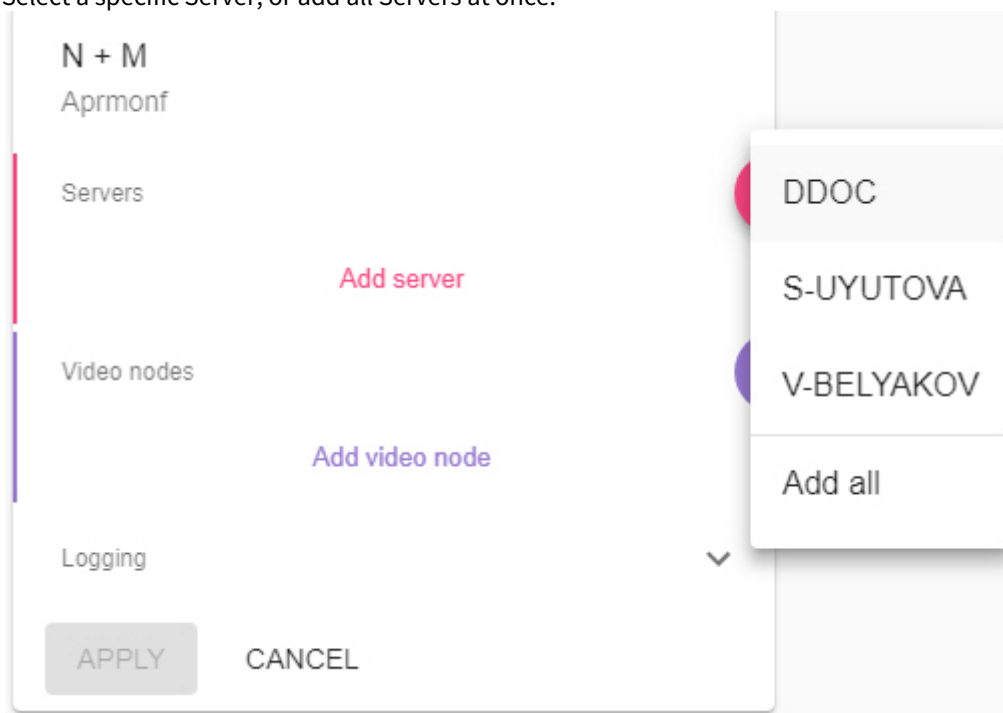

4. Create nodes:

- a. Click .
- b. Enter the node name and click the **Proceed** button.

Node Name *

Node-Octthur|

PROCEED

Attention!

A node name may contain Latin and numerical characters, and the "-" symbol.

- c. Create the required number of nodes.

Attention!

The number of nodes should be less than the number of Servers.

5. By default, the self-diagnostics service is running on all nodes (see [Self-diagnostics service](#)). To stop it, de-activate the **Self-diagnostics** parameter (1).

The screenshot shows a configuration window for nodes. At the top, it says 'N + M' and 'Rsiantu'. Below this, there are three nodes listed under 'Servers': 'E-LAZAREV', 'S-UYUTOVA', and 'V-BELYAKOV'. Each node has a red '+' button to its right. Below the servers, there are two nodes listed under 'Video nodes': 'Node-Janmonj' and 'Node-Epwedne'. Each node has a purple '+' button to its right. The 'Self diagnostics' parameter is set to '1' and has a red toggle switch turned on. The 'Logging' section is expanded, showing 'Logging level' set to '2' (Info), 'Size limit (MBytes)' set to '3' (500), 'How long to record (hours)' set to '4' (24), and 'How long to keep (days)' set to '5' (7). At the bottom, there are 'APPLY' and 'CANCEL' buttons.

6. Click the **Logging** button to set the logging options:
 - a. Select Logging Level (2, see [Configuring Logging Levels](#)).
 - b. Set the settings for the archive of logs (3-5, see [Configuring a Log Archive](#)).
7. Click the **Apply** button.

The configuration is now created, and the nodes are now automatically started.

- 8. Merge all nodes into a single Axxon domain (see [Connecting to a Node and Configuring of an Axxon domain](#)).
- 9. In a Failover system, we recommend you to physically locate the footage archive on a separate NAS that all servers in the cluster have access to.

For each node, create a separate archive on the NAS (see [Creating a network archive](#)).

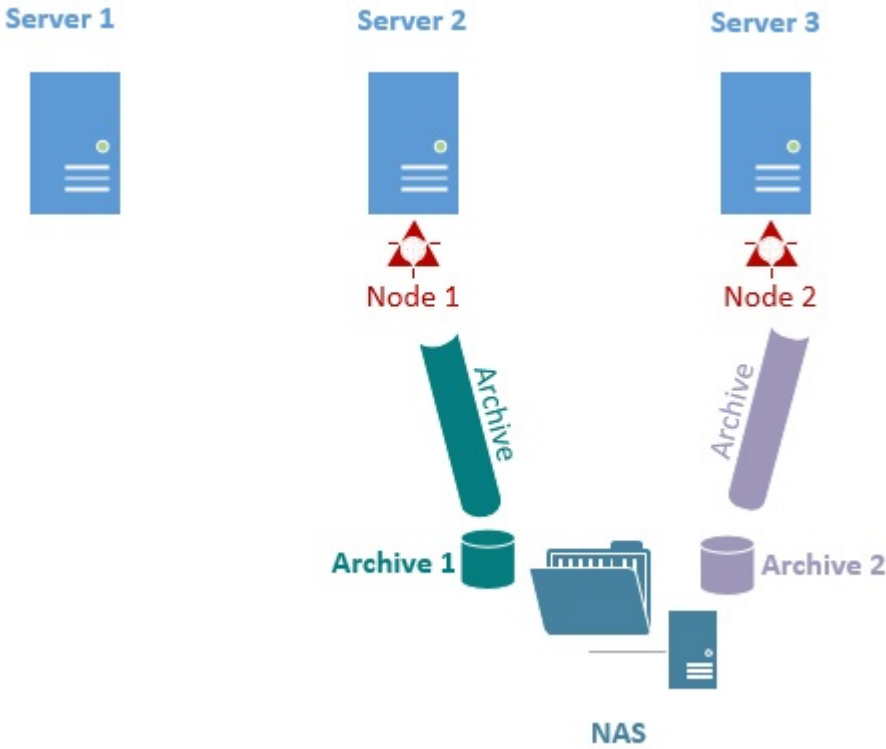

If the node is moved to a different server, it will continue to write to the specified archive.

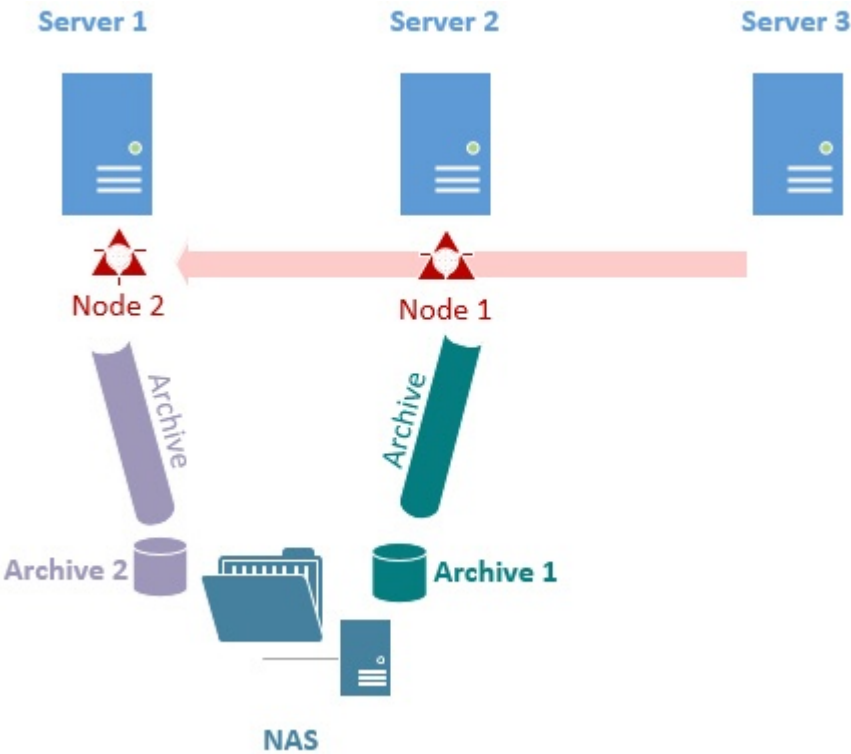

The basic configuration of the Failover system is now complete.

If necessary, you can further edit the configuration. To do so, click . You can perform the following actions:

- add / remove Servers;
- add / delete nodes;
- activate / de-activate the self-diagnostics service;
- change logging parameters;
- completely remove the configuration.

To manually stop or launch a node, click  and select the required action.

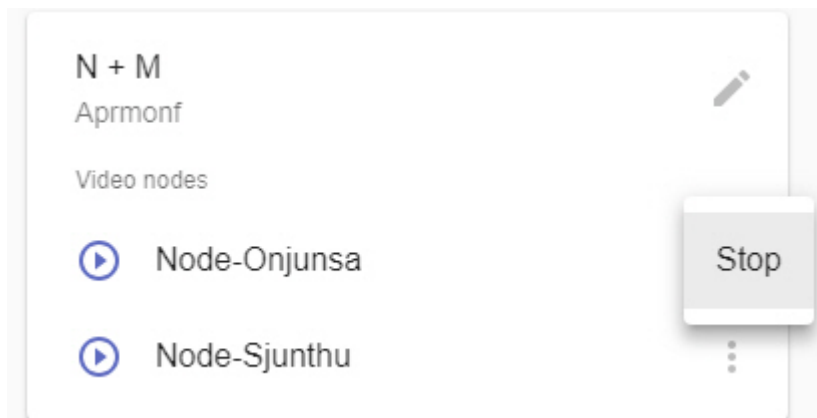



7.11.6.2 Setting up a configuration with the backup Server

A configuration with the backup Server can include two or more Servers.

To set up the configuration, do the following:

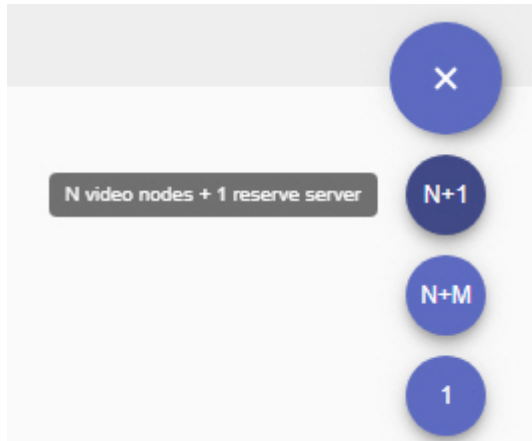
1. Hover the mouse cursor over the  button and click the **N+1** button.



- Click  and assign a backup Server.

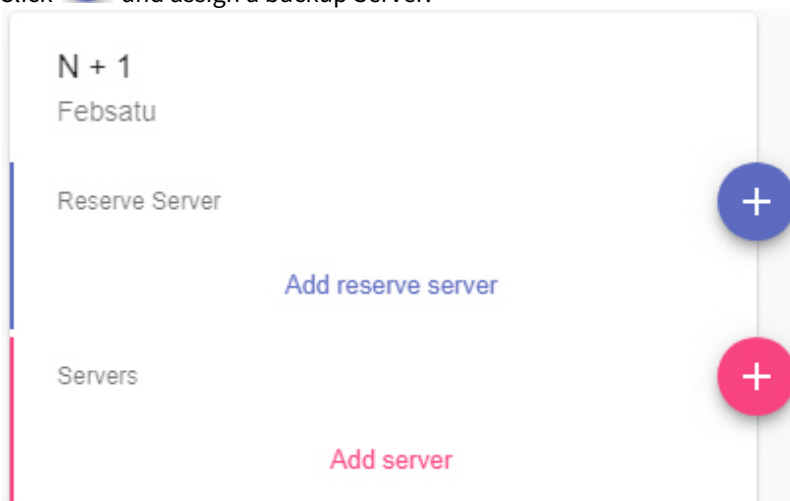

- Click  and add primary Servers.
- If you need to maintain a local event database on Servers, activate the corresponding switch **(1)**.

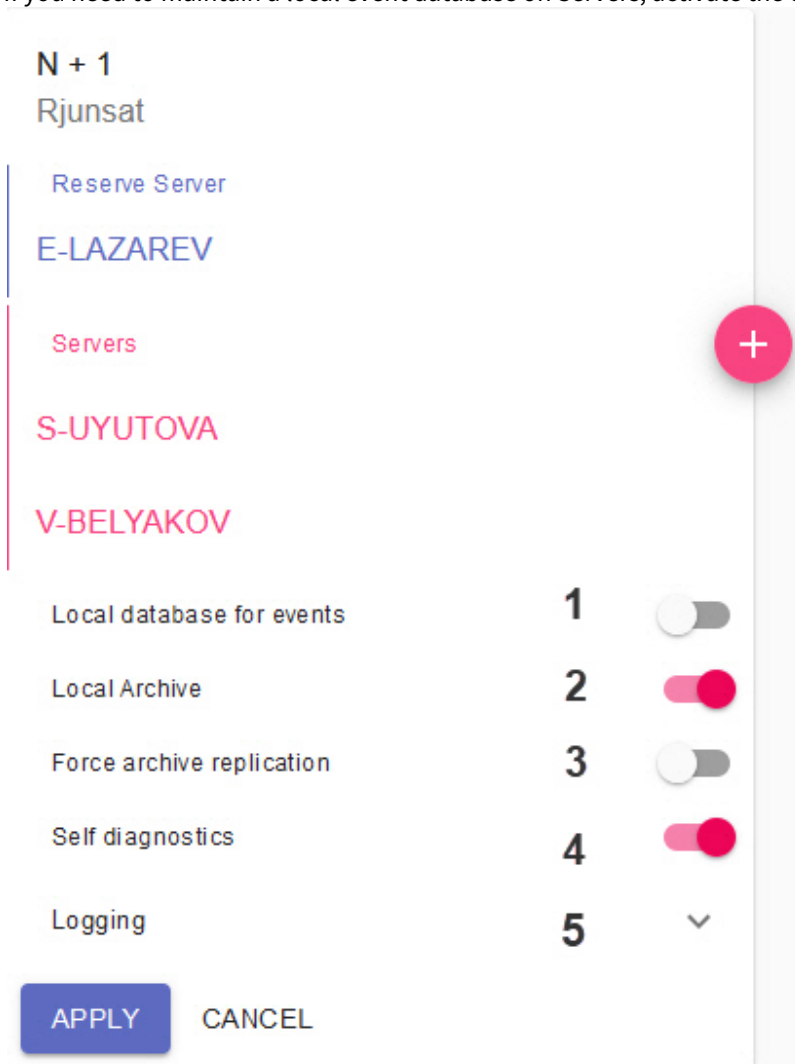

- If you need to maintain local footage archives on primary Servers, activate the corresponding switch **(2)**.

Attention!

The local video footage will be created as a 10 GB file located in the C:/temp_arch folder. If the node is migrated from a primary Server to a backup one, video data will be recorded to this file and replicated to the main Archive (video footage) on the backup Server (see paragraph 10).

6. If you need to replicate local archives to the backup Server on permanent basis, activate the corresponding switch **(3)**. Otherwise, the replication will be performed only when the corresponding node is migrated to the backup server.
7. By default, the self-diagnostics service is running on all nodes (see [Self-diagnostics service](#)). To stop it, de-activate the **Self-diagnostics** parameter **(4)**.
8. Click the **Logging** button to set the logging options **(5)**, see [Setting up basic configuration](#)).
9. Click the **Apply** button.
The configuration is now created, and the nodes are now automatically started. "Failover" string will be automatically added to the name of the backup node.

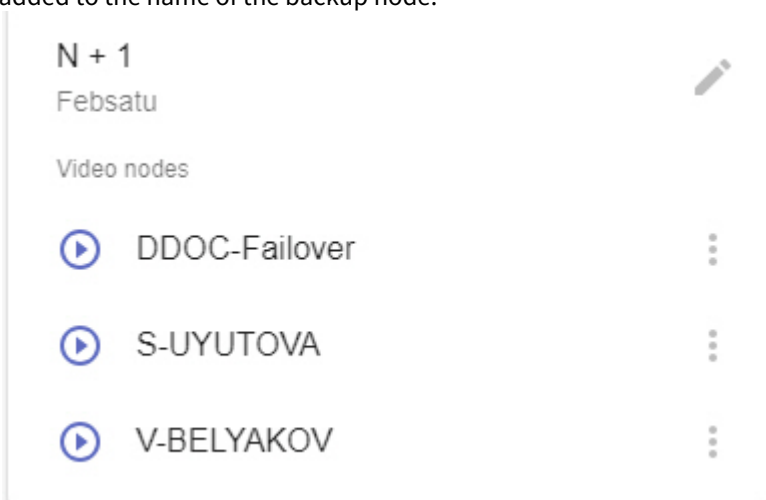

10. Merge all nodes into a single Axxon domain (see [Connecting to a Node and Configuring of an Axxon domain](#)).
11. Configure the footage archives operation:
 - a. On the backup node, create an archive for replication (see [Creating archives](#)).
 - b. On the primary nodes, configure the replication from the primary Servers' archives to the backup node's archive. The replication period should be set to **Always** (see [Configuring data replication](#)). You have to set the replication

time period to **Always** regardless of the value of the **Forced Replication** parameter (see paragraph 6).

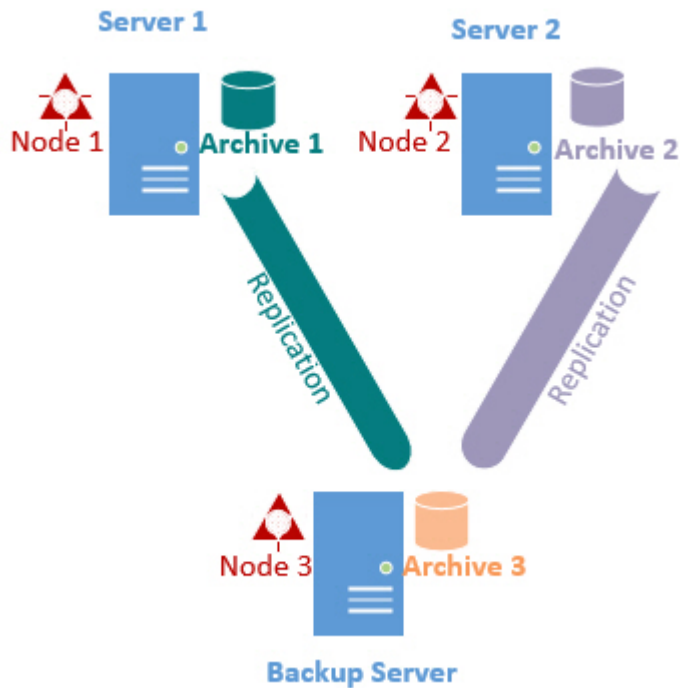

Configuration of the Failover system is now complete.

When a node is migrated to the Failover Server, the latter creates a temporary 10 GB archive in C:\temp_arch which Axxon Next refers to as **Archive in Failover Server**.

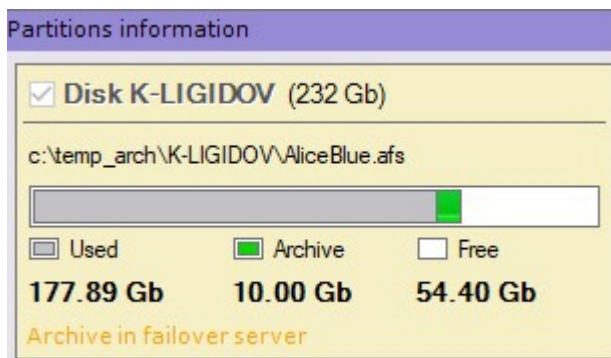

Its records will be replicated to Backup Server's main archive (see **Archive 3** on the picture above).

If necessary, you can further edit the configuration. To do so, click . You can perform the following actions:

- add / remove Servers;
- add / delete nodes;
- activate / de-activate the self-diagnostics service;
- change logging parameters;
- completely remove the configuration.

To manually stop or launch a node, click  and select the required action.



7.11.6.3 Creating and configuring independent nodes

You can host separate nodes on cluster's Servers which are not used by any configuration.

Failover doesn't cover these nodes since they rely on local databases. If the host Server fails, the nodes can not be migrated.

To create an independent node, do as follows:

1. Go to the **Configuration** tab.
2. Point the cursor at  and click **1**.

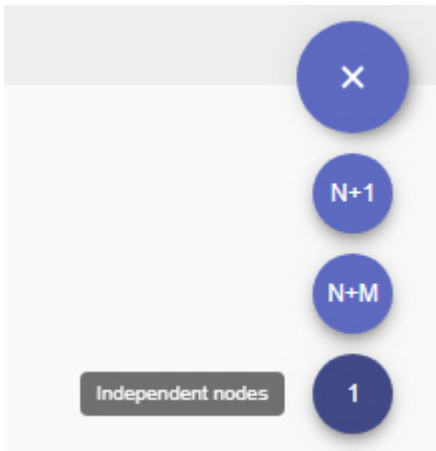

3. Click  and select Servers where independent nodes should be launched.

Attention!

You can create only one independent node on each server.

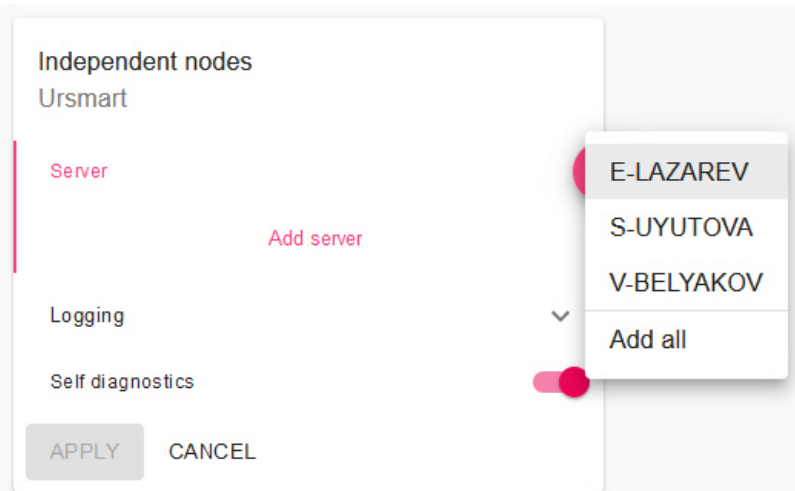

4. By default, the self-diagnostics service is running (see [Self-diagnostics service](#)). To stop it, de-activate the **Self-diagnostics** parameter (1).

- 5. Click the **Logging** button to set the logging options (see [Setting up basic configuration](#)).

Independent nodes

Sepsatu

Server

DDOC

S-UYUTOVA

V-BELYAKOV

Logging

Logging level

Info

Size limit (MBytes)

500

How long to record (hours)

24

How long to keep (days)

7

APPLY CANCEL

- 6. Click the **Apply** button.

The nodes are now created; they should start automatically.



7.11.6.4 1+1 Cluster Configuration

Before setting up a cluster in this configuration, you have to initialize the cluster after two Servers have been added.

- Set server address ——— Link other servers ——— Create user ——— 4 Bootstrap

Confirm creating configuration **1+1**

 10.0.11.66

 10.0.11.103

BACK

INITIALIZE

In this case, the primary node will reside on the Server from which the cluster was initialized.

If a cluster has been initialized on one Server only:

1. Add the second Server to the configuration.
2. Click the **Convert to 1+1** button on the **Configuration** page.

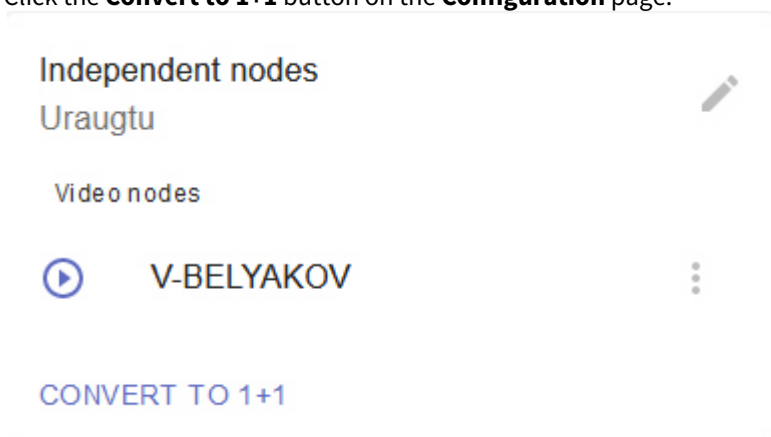

If necessary, you can further edit the configuration. To do so, click



. You can perform the following actions:

- activate / de-activate the self-diagnostics service;

- change logging parameters;

In this configuration, a local Archive (video footage) will be automatically created as a 10 GB file located in the C:/temp_arch folder.

If a node is transferred to a backup Server, the primary archive must be replicated as a backup archive. To do it, follow the steps below:

1. On the backup node, create an archive for replication (see [Creating archives](#)).
2. On the primary nodes, configure the replication from the primary Servers' archives to the backup node's archive. The replication period should be set to **Always** (see [Configuring data replication](#)). You have to set the replication time period to **Always**.

Note

Further changes in the configuration may include only logging parameters. To do this, click the button .

Attention!

If the backup Server fails while the system is running, you cannot stop the primary node.

If the backup server is down, the primary node will not restart.

7.11.6.5 Suspending a Server within a cluster

In some cases, you may need to temporarily suspend the operation of a Server within a cluster. To do this:

1. Open the Server menu on the **Configuration** page.
2. Activate the **Maintenance** switch.

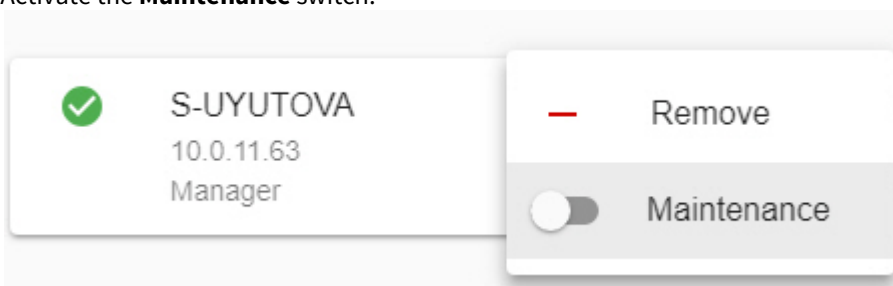

All Server's nodes then migrate to other Servers, and the status of the Server is updated.

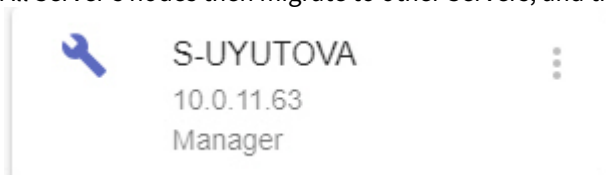

To resume the Server's operation within the cluster, toggle the Service switch to its initial position.

7.11.6.6 Disbanding a cluster

To disband a cluster, do the following:

1. Go to the **Hosts** page.

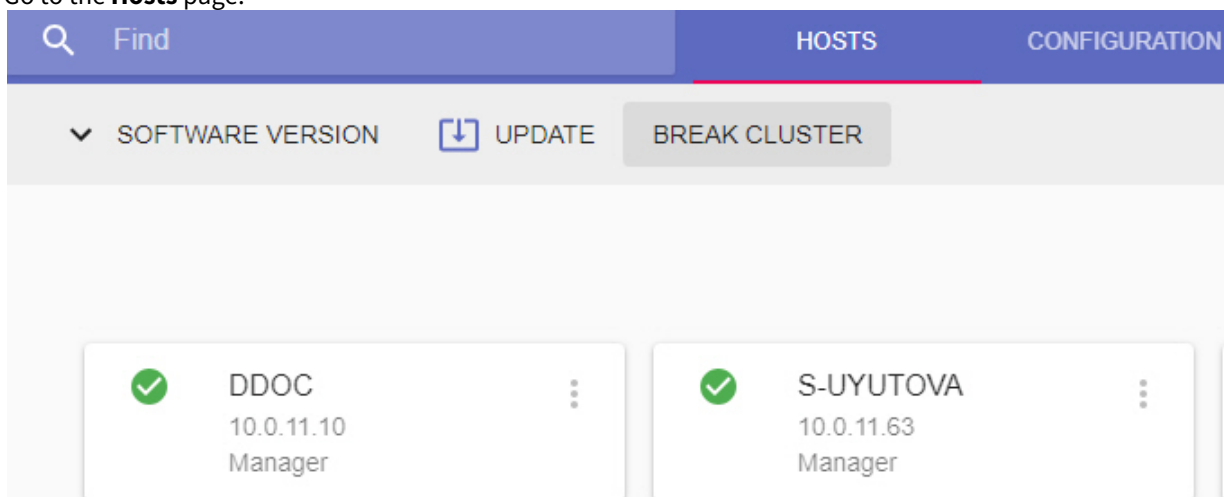

2. Click the **Break Cluster** button.

3. Confirm the action.

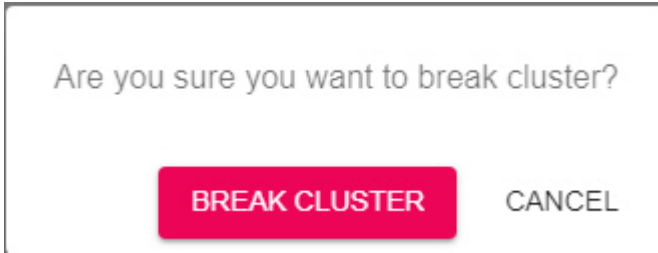

The cluster is now disbanded.

7.11.7 Set up access to a supervisor

When you launch the supervisor for the first time and create the cluster, you can create a user with the **Administrator** role (see [Creating a Cluster](#)).

In the future, you can create users with two roles: **Administrator** or **Operator**. Administrators have full access to the cluster configuration while operators can only view the configuration and monitor the state of the system.

Users can be created in the **Users** tab. To create a user:

1. Click the  button.
2. Enter the user's login (1).

 A blue modal form for creating a user. It has a close button (X) in the top right corner. The form contains three input fields: "Login" (labeled 1), "Password" (labeled 2), and "Role" (a dropdown menu currently showing "Administrator", labeled 3). At the bottom left is a button labeled "ADD USER" (labeled 4).

3. Enter the user's password (2).
4. Select the role to which the user will be added (3).

Note

The first user you create will be automatically added to the **Administrators** role

5. Click the **Add User** button (4).

User creation is complete. Click  to edit the user.

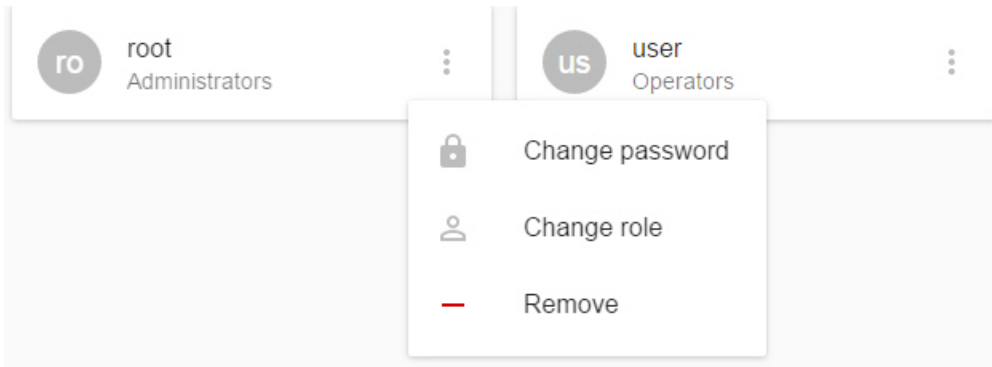

The following operations are allowed:

- Change password.
- Change role.
- Delete user.

If at least one user was created, then the authentication is required when connecting to the Supervisor web interface.

Authentication

Login

Password

[AUTHENTICATE](#)

7.11.8 Configuration backup and restore for failover VMS

You can back up your cluster, DBs, and nodes configuration and restore it.

By default, backup copies of the cluster configuration are created each 24 hours on each Manager Server. If a backup copy was created by operator's command, the next automatic backup will be performed not earlier than after 24 hours.

Attention!

The object trajectory DB cannot be backed up. In the event of server hardware failure, all metadata stored in the database will be lost irretrievably.

To create a backup:

1. Go to the **Configuration** tab.
2. Click the **Back up** button (1) and download the backup by clicking the  button.

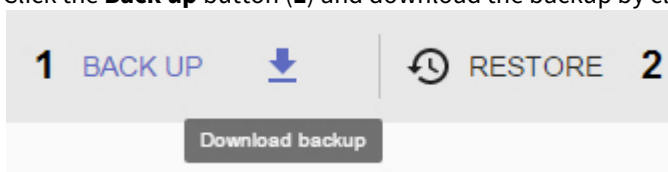

To restore a configuration from a backup:

Create a cluster first.

1. Go to the **Configuration** tab.
2. Click the **Restore** button (2) and select the file with the configuration backup.

Restore cluster from

svisor-2017-03-20T16-02-47+04-00.backup

 RESTORE

3. Click the **Restore** button.

Attention!

Restoring configuration will stop all active tasks.

Configuration restore completed.

To transfer the configuration from a common security server to a failover system:

1. Create a copy of the configuration on the server (see [Backing up a configuration](#)).
2. Connect to the configuration backup and restore utility on the node (see [Connecting to a Node and Configuring of an Axxon domain](#)).

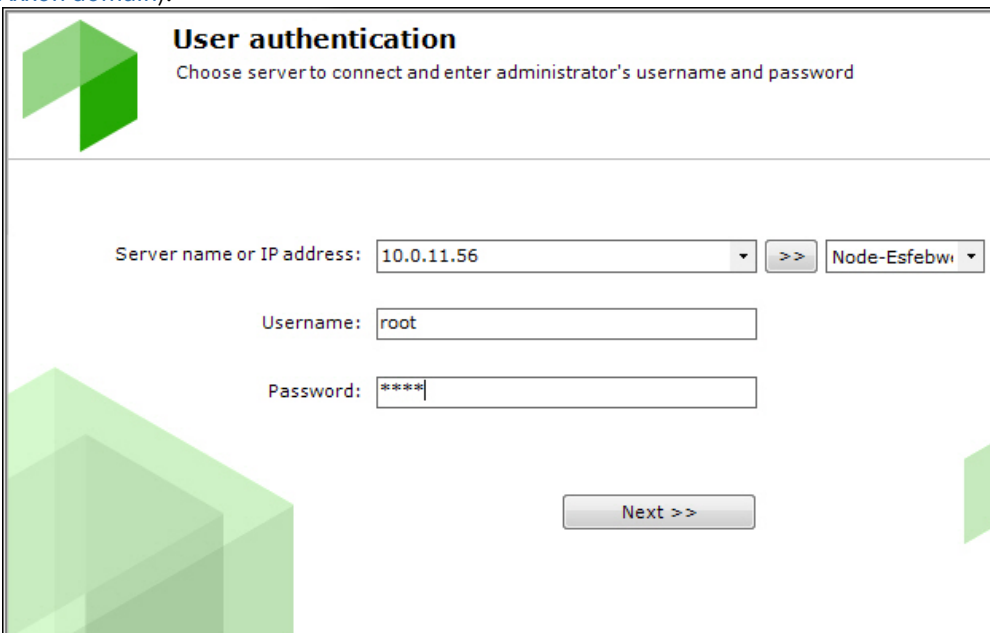

User authentication
Choose server to connect and enter administrator's username and password

Server name or IP address: >>

Username:

Password:

3. Restore the saved configuration (see [Restoring a configuration](#)).

7.11.9 Cluster Monitoring

You can monitor clusters in the **Dashboard** tab.

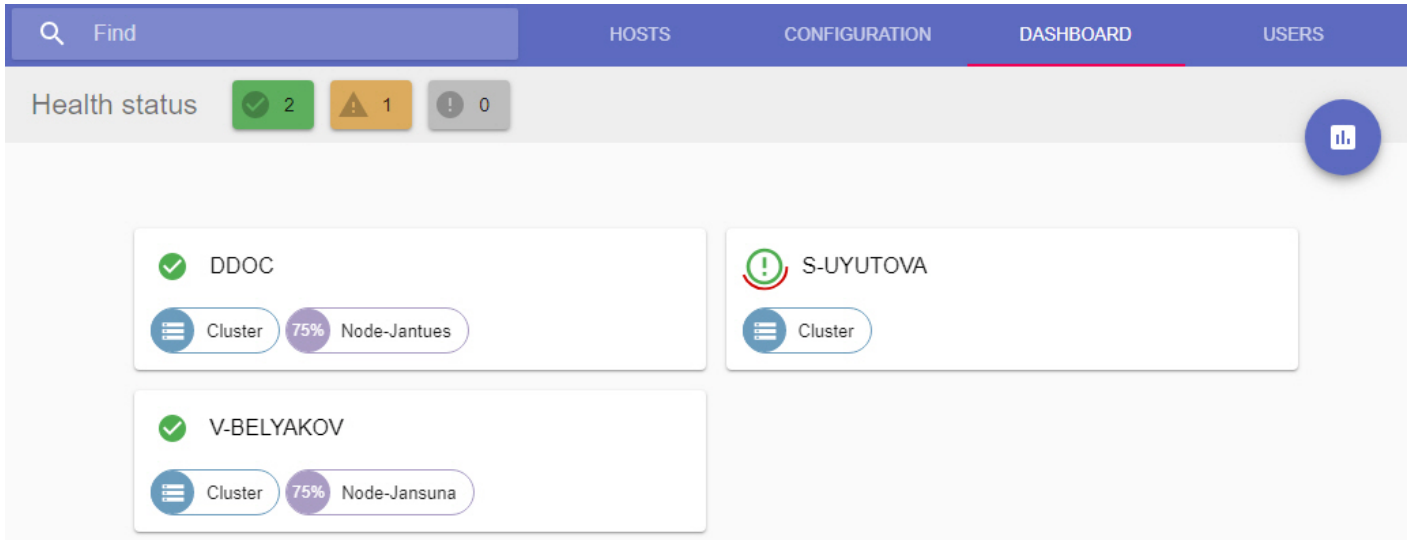

The following information is available:

1. The status of all cluster servers. All cluster servers are cross-checked against a number of criteria. The status info of a server reflects the cross-check results.

Status	Description
	The server successfully passed all checks.
	The server did not pass some checks. The red stripe around the icon reflects the percentage of failed checks.

2. The percentage of allocated CPU resources is calculated for all running nodes. For example, for a node consuming 9300 standard units out of total of 12400, the percentage is: $(9300/12400) * 100\% = 75\%$.

Attention!

This parameter does not reflect the actual Server CPU load; the amount of the node related load can be either higher or lower than the displayed value.

3. Running database servers and their statuses.

Status	Description
	The database server is running.
	The database server is running, some checks failed.
	The database server is stopped.

To open the CPU server load diagram, click **Show Resource**.

✔ DDOC
Cluster 75% Node-Jantues

You can filter servers by status using the **Health status** panel.

Status	Description
1	Servers that passed all checks.
2	Servers that did not pass some of the checks.
0	Servers that failed all checks.

The icon indicates the number of cluster servers in this status

7.11.10 Connecting to a Node and Configuring of an Axxon domain

When the cluster is configured, connect the client to the node. Do the following:

1. Start the Client (see [Starting an Axxon Next Client](#)).

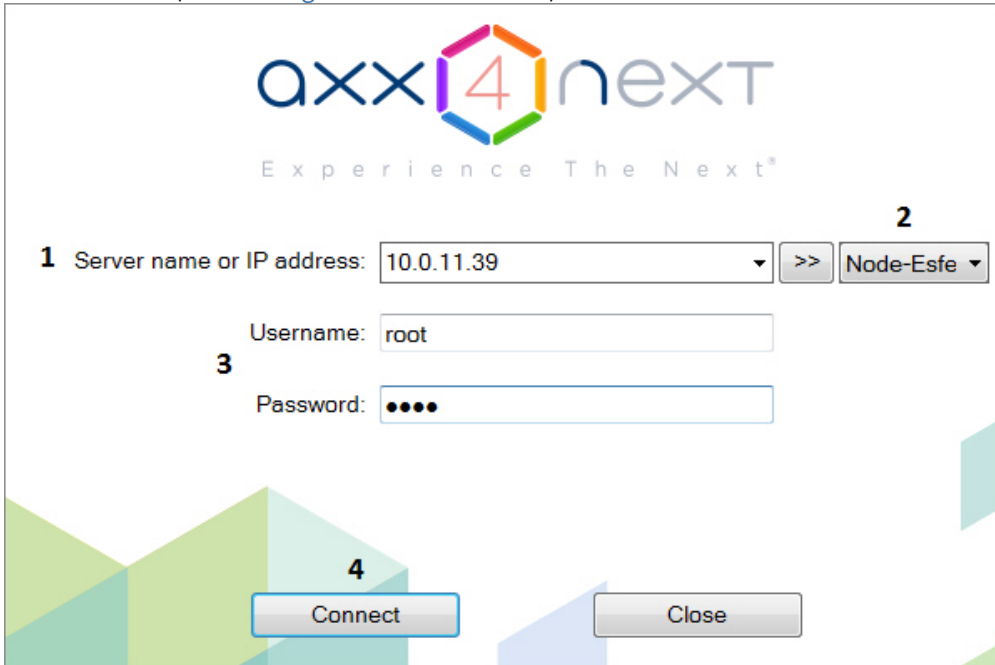

2. Enter the IP address of any cluster server (1) and click the >> button.

Attention!

You cannot connect to a node located behind a NAT.

3. Select from the list the node you want to connect to (2). Enter first characters of the node name into this field, and the fast search starts.
4. Enter the user name and password (3) and click **Connect** (4).

During the first connection to the node, you will be prompted to create an Axxon domain (see [Creating a new domain](#)).

You can then merge nodes into a unified logical structure following standard procedures of Axxon domain configuration (see [Configuring Axxon domains](#)).

Attention!

An Axxon domain cannot include nodes from different clusters.

7.11.11 Configuring automatic connections to nodes

Configuring automatic connections to a failover system is similar to setting up an automatic connection to a common security server (see [Configuring Cross-System Client and autologon](#)), with a few minor changes. To add a node to autostart, do as follows:

1. Select the **Discover cluster** check box (1).

2. Enter the IP address of any cluster server (2) and click the button (3).
3. Select from the list the node you want to add to autostart (4).
4. Click the **Add** button (5).

7.11.12 Upgrading Servers within a cluster

To upgrade all Servers within a cluster, do the following:

1. Go to the **Hosts** page.

2. Click **Update**.

Attention!

You can bulk upgrade the entire cluster only if all of its servers are accessible.

3. On your PC, select the required distribution in zip archive, or specify a web link (1).

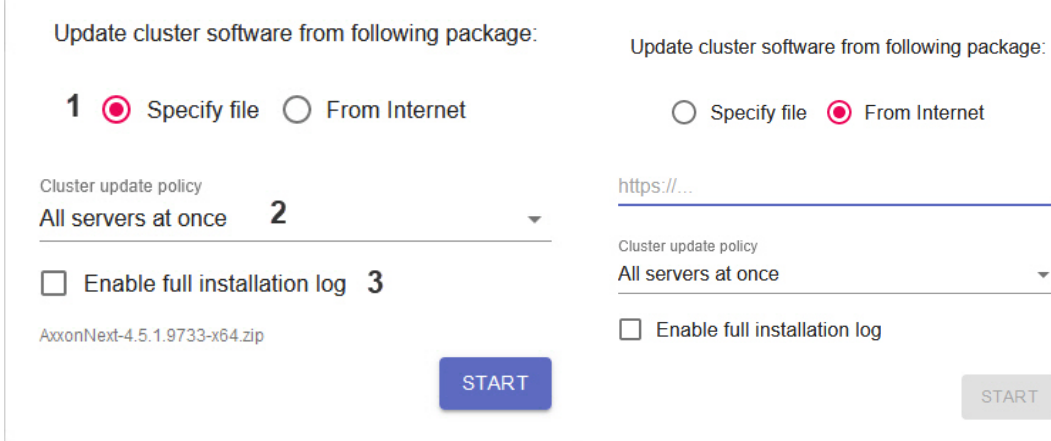

- 4. Select the update method: all Servers simultaneously, or one after another (2). In the former case, all nodes operation will be halted until the update is finished, in the latter case the nodes will operate without interruption.
- 5. To record all installation-related events to a log file (3), select the **Enable full installation log** check box.
- 6. Click **Start**.

The installation package download starts. You can cancel the update unless the download is complete.

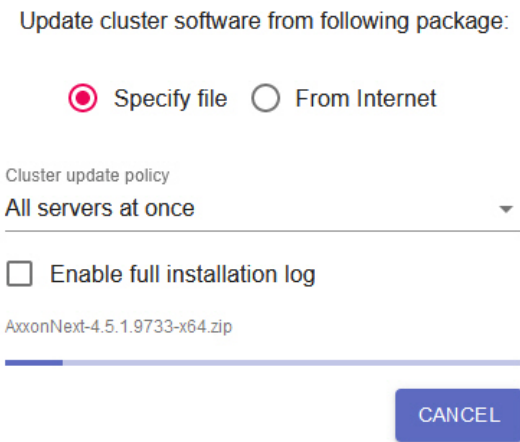

7. After the installation package is downloaded, the Axxon Next software suite will be updated in quiet mode on all Servers within the cluster. Depending on the previously selected update method, the Servers will be updated simultaneously or one after another.

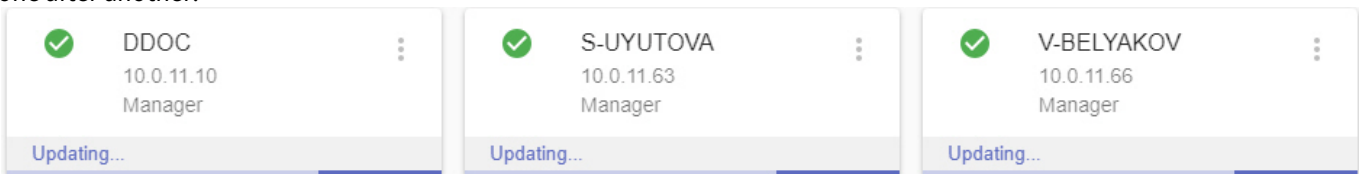

After the update is completed on a Server, its status will change to **Done**.

Note

If the upgrade fails, you will see the **Error** message in the status bar.

After all Servers within the cluster are updated, the status at the top of the page will also change.

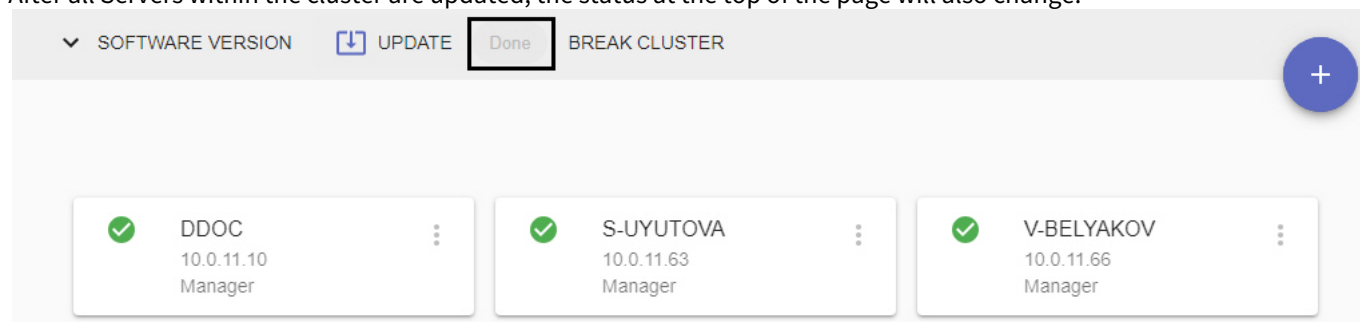

7.11.13 Setting network interfaces for system nodes operation

By default, failover system nodes use all available network interfaces.

To limit the number of network interfaces, do the following:

1. Locate the file C:\Program Files\RaftLauncher\current\raft-settings.xml and add a new parameter:

```
<item key="NGP_IFACE_WHITELIST">172.17.0.0/16</item>
```

Use the following settings format: "IP-address1 / number of unit bits in the mask, IP-address2 / number of unit bits in the mask"

2. Add the same parameter to another file: C:\Program Files\AxxonSoft\AxxonNext\bin\raft\raft-settings.xml .

7.12 Self-diagnostics service

7.12.1 What is the self-diagnostics service

This is a service that tests operability of Axxon Next's internal components, and launches pre-specified actions in case of emergency.

Type of failure	Action
Out of RAM	Relaunch of Axxon Next's most RAM-consuming process.
Camera is connected but does not send data	Relaunch of the corresponding process or micro-service.
No events from a detection tool	Relaunch of the corresponding process or micro-service.
No records in Video Footage	Relaunch of the corresponding process or micro-service.
No footage is recorded on detection	Relaunch of the corresponding process or micro-service.
Out of system disk space	Deletion of logs. Clearing the database from system events of more than 7 days old.

Note

Aside from the listed errors, the service detects internal errors of the Axxon Next software, and performs required actions for each case.

7.12.2 Starting and stopping the self-diagnostics service

To launch the self-diagnostics service, complete one of the following two actions:

1. Select the **Start self-diagnostics** command in the [Axxon Next Tray Tool](#) utility,

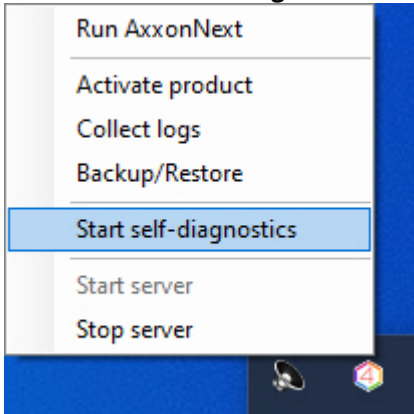

2. Launch the NGP_Self_Diagnostics.

Note

In a failover system, the self-diagnostics service is activated / de-activated in cluster settings (see [Configure a Failover System Cluster](#)).

To stop the self-diagnostics service, complete one of the following actions:

1. Select the **Stop self-diagnostics** command in the [Axxon Next Tray Tool](#) utility,
2. Stop the NGP_Self_Diagnostics.

8 Working with the Axxon Next Software Package

8.1 Main Elements of the User Interface

8.1.1 Viewing Tile

A viewing tile is used to display video stream on the monitor of a computer with specific parameters for the purpose of video surveillance, archive viewing, and forensic search in archives. The viewing tile also has a function which allows the generation and evaluation of alarm events in the process of video monitoring of a guarded location.

The Camera window has flexible display options (see [Configuring the Appearance of the Viewing Tile](#)):

- Control buttons over the video image, mode selector buttons inside the window.

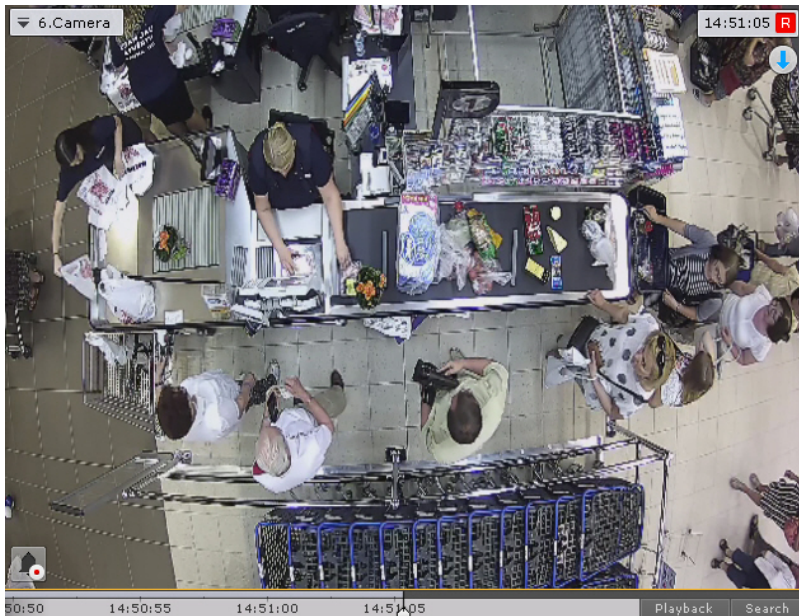

- Control buttons over the video, selector buttons outside.



- Control buttons outside the video, selector buttons inside.

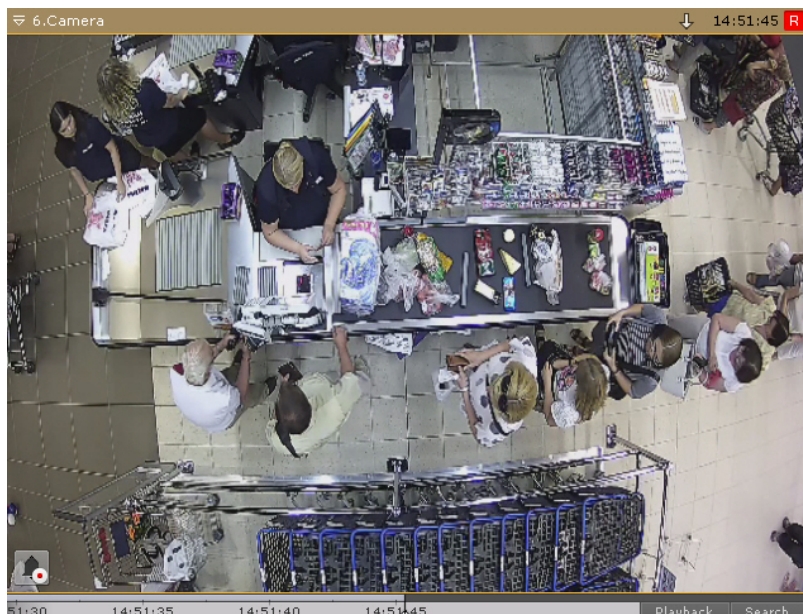

- Control buttons and selector buttons outside the video image.

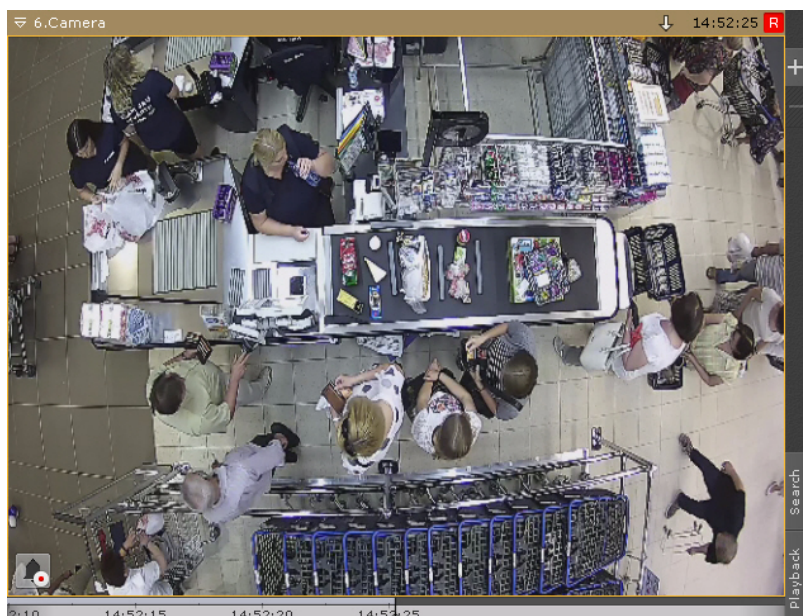

There are two states of a camera window within the layout: active or inactive.

A window in active state includes an additional navigation panel (see [Advanced archive navigation panel](#)) and video mode selection tabs (see [Video Surveillance Mode Selection Tabs](#)).

To switch a window to active state, click anywhere inside the window; clicking outside de-activates it.

A more detailed description of the functions of the viewing tile can be found in the section titled [Video Surveillance](#).

If the connection to the camera is lost, the camera window is darkened and you get a corresponding message on the most recently received image.

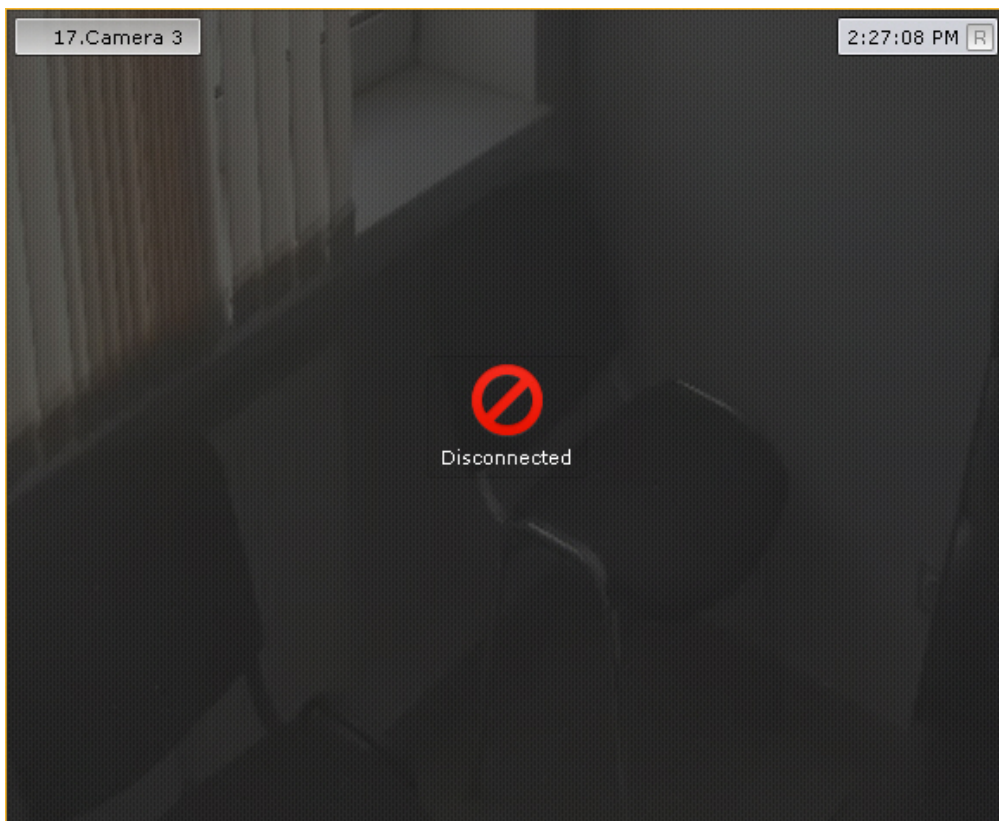

To copy the camera name to the Clipboard, right-click on it

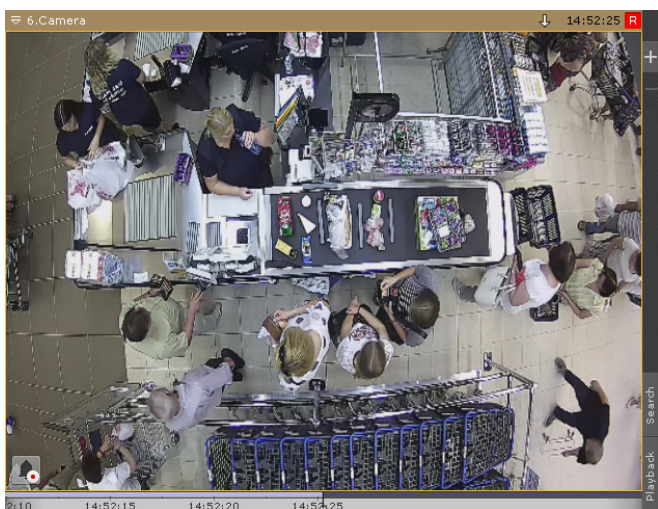
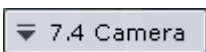

8.1.1.1 Color Coding of Frames

Color coding of the frame of a viewing tile is used to indicate the status of the video camera.

Color of viewing tile frame	Camera status
Red	Active alarm
<u>No active camera alarms</u>	
Green	Camera disarmed

Yellow	Camera armed
Gray	Archive mode

8.1.1.2 Viewing Tile Context Menu

The viewing tile context menu is used to access the following functions (depending on the enabled surveillance mode):

1. Video surveillance
2. Audio monitoring
3. Exporting frames and recordings
4. Object tracking

To bring up the viewing tile context menu (1), left-click the video camera icon in the upper left-hand corner of the tile (2).

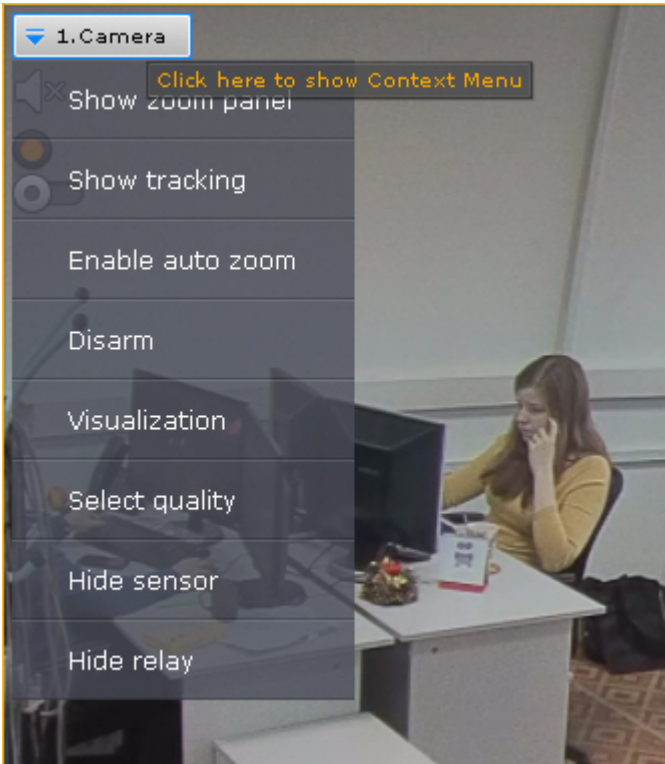

8.1.1.3 Time Display

The time display appears in the upper right-hand corner of the viewing tile.



Note

Depending on the settings (see [Configure Time Display](#)), the indicator may show the date 7/18/2016 3:44:49 PM **R**

Current time of Client is displayed on the indicator in real-time mode: 15:03:32 **R**.

If the Client's time is different from the Server time, the Server time will also be displayed below the indicator.

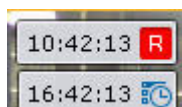

In archive, alarm, and video frame search modes, it shows the time of the fragment being viewed and the playback mode:

1. Forward playback ▶ 9:02:35 **R**.
2. Reverse playback ◀ 9:02:38 **R**.
3. Pause ⏸ 9:02:31 **R**.

If the video is currently being recorded from the camera, the letter **R** is displayed in red to the right of the clock: 15:03:32 **R**

. Otherwise, the letter **R** is displayed in gray: 15:03:54 **R**.

If the camera is not linked to the archive, the letter **R** is crossed out: 03.06 13:10:00 ~~**R**~~.

8.1.1.4 Display of Video Statistics

You can display video statistics in the viewing tile (see the section titled [Configuring Display of Video Statistics](#)). In real-time mode the video display statistics are shown. In Alarm, Archive, and Clip Search modes, it shows the time of the fragment being viewed and the playback mode:



Video statistic	Parameter description
Client-side FPS	Frame rate of the displayed video stream.
Server-side FPS	Frame rate of the video stream received from a video camera or an archive.
Bitrate	Bitrate of a compressed video stream.
Frame size	Resolution of the displayed video stream.

Note

The video stream parameters are updated every 10 seconds.

8.1.1.5 Video Surveillance Mode Selection Tabs

To select the video surveillance mode, use the tabs in the lower right-hand part of the viewing tile:



Alarm Management mode is activated when an alarm is triggered (see [Initiating an Alarm](#)).

8.1.1.6 Advanced archive navigation panel

The advanced archive navigation panel is displayed in the lower portion of the screen in **Archive** or **Archive Search** modes.

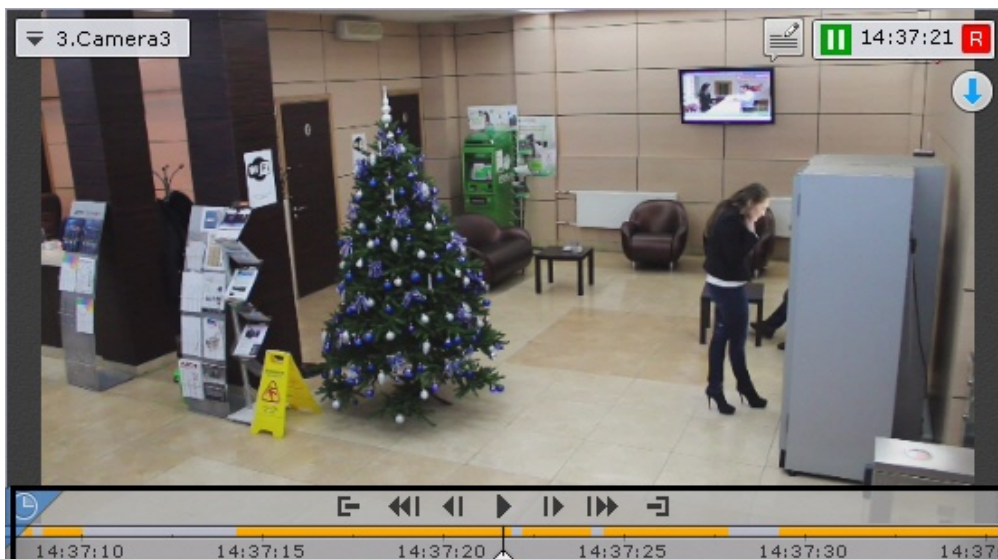

When you click a live camera tile, the advanced navigation panel shows only the timeline and the archive selection button.



Note

If the camera is not linked to a video archive, the panel will be unavailable

In Live Video mode, if you click the timeline, you go to Archive mode.

The advanced archive navigation panel includes the following components:

1. Timeline;
2. Playback control buttons;
3. Archive selection button;
4. Tabs for compressed and standard archive playback modes.



Tracks are marked in different colors depending on the alarm status or detection tool activation:



Condition	Track color
Archive absent (1)	Gray
Archive (2)	White
Archive present, alarm active (3)	Red
Archive present, detection tool activated (no alarm) (4)	Yellow

Additionally, the timeline on the advanced archive navigation panel features missing footage tags . A tag is displayed when footage is missing for over 40% of the currently visible part of the timeline.

Depending on the duration of the missing footage, tags may have different thickness:

1.  - less than one hour;
2.  - from 1 to 24 hours;
3.  - more than 24 hours.

The duration of missing footage is indicated near the tag.

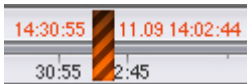

The date of the first recording in a Video Footage archive is displayed near the left edge of the archive stripe.



Note

In this case, the archive portion left of the marker  contains videos shot when the camera was not linked to this particular Archive.

The advanced archive navigation panel is used to position the archive at a specific time, control playback, and switch to compressed archive playback mode.

The advanced archive navigation panel works completely in sync with the playback panel and the timeline:

1. The playback mode selected on the advanced navigation panel is displayed on the playback panel.
2. The playback speed that is set on the playback panel will be used as the playback speed when playback is restarted on the advanced navigation panel, and vice versa.
3. The playback control buttons on the advanced navigation panel are the same as the buttons on the playback panel.
4. Any movement through the main timeline is duplicated onto the timeline of the advanced navigation panel.

8.1.2 Information boards

Information boards offer a quick view of system status and events. There are three kinds of information boards, each displaying a specific type of information:

1. Events Board (1).
2. Health Board (2).
3. Statistics Board (3).
4. Dialog board (4).
5. Web board (5).

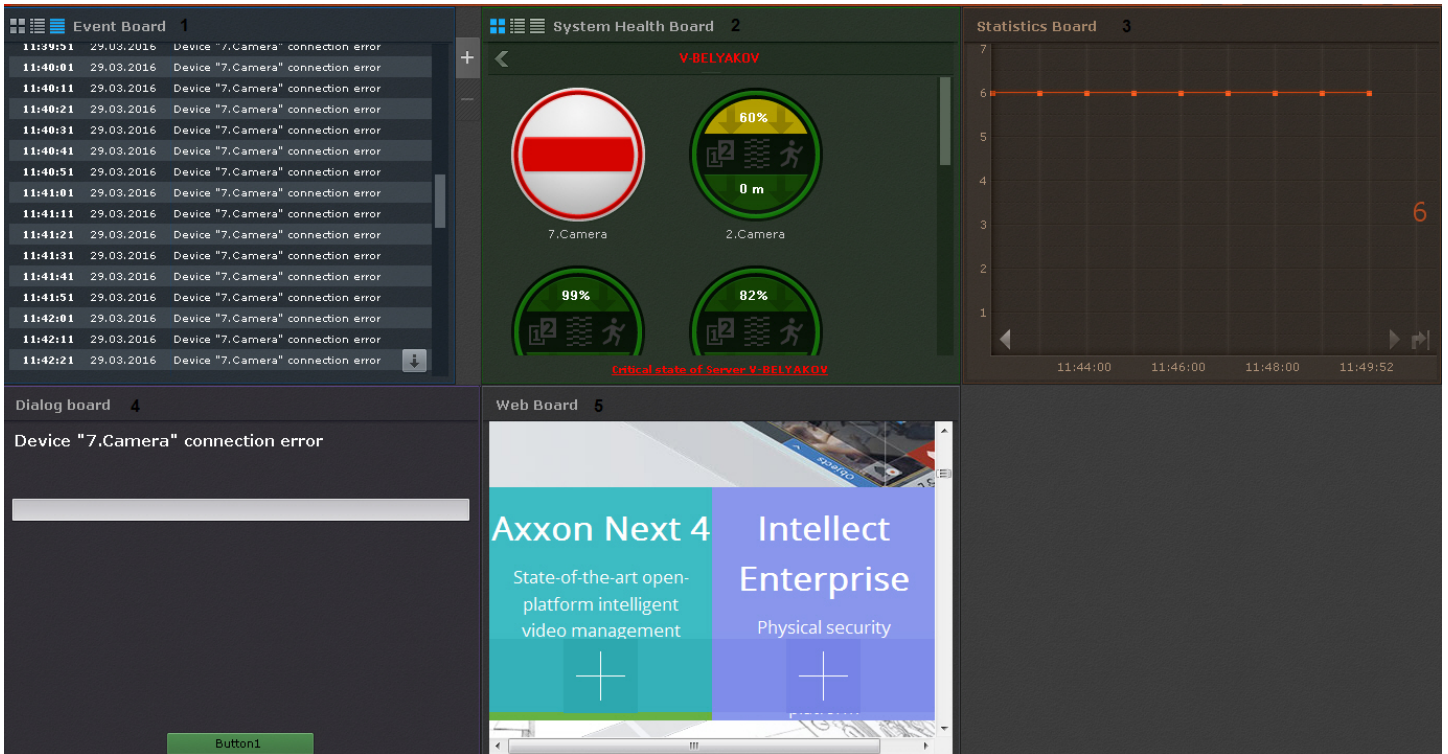

To learn about information boards, consult the relevant [section](#).

8.1.3 The Archive Navigation Panel

8.1.3.1 Show and Hide the Archive Navigation Panel

The Archive Navigation Panel is located on the right side of the screen and is automatically displayed when you switch to archive mode (see [Switching to Archive Mode](#)).

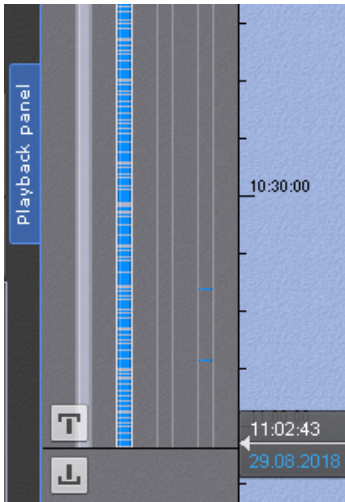

To show/hide the panel, press the **Playback Panel** button.

8.1.3.2 The Structure and Function of the Archive Navigation Panel

The archive navigation panel is automatically displayed in the right-hand part of the screen when you switch the viewing tile to Archive or Search for Clip by Frame mode.

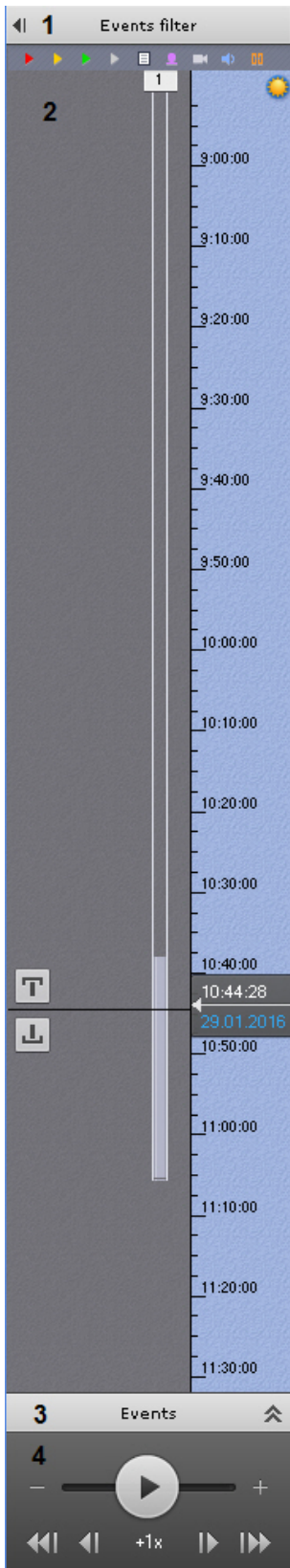

The archive navigation panel includes the following components:

1. The alarm events filter **(1)**.
2. Timeline **(2)**.
3. Events List **(3)**.
4. Playback panel **(4)**.

The archive navigation panel is used for the following functions:

1. Navigating through the archive.
2. Playing back recordings.
3. Selecting playback mode: forward or backward.
4. Setting playback speed.
5. Selecting events for display on the timeline and in the events list.
6. Viewing the list of events of the selected type.

8.1.3.3 Events Filter

The **Events Filter** component allows selecting the type of events that are displayed on the archive navigation panel.

To select an event type:

1. Click the **Events filter** button (1). The **Events filter** window will then be displayed (2).

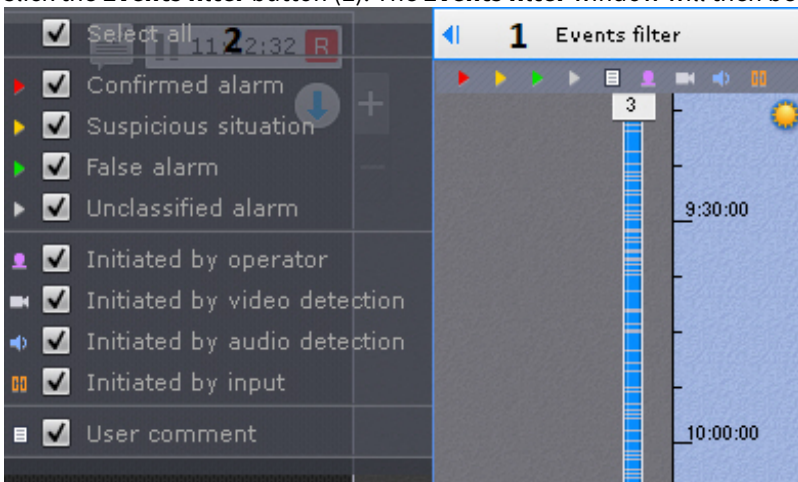

2. Select the check boxes for the types of alarms which should be displayed on the archive navigation panel, according to their status:
 - a. Confirmed alarm
 - b. Suspicious situation
 - c. False alarm
 - d. Unclassified alarm
 - e.

Note.
If you clear the check box for a certain type of alarm, this type of alarm and the corresponding track are no longer displayed on the timeline

3. Select the check boxes for the types of alarms which should be displayed on the archive navigation panel, according to the cause of their initiation:
 - a. Initiated by operator
 - b. Initiated by video detection tool (basic, situation analysis, or embedded)
 - c. Initiated by audio detection tool (basic, situation analysis, or embedded)
 - d. Initiated by input

Note.
By default, all check boxes are already selected.

Attention
To display alarms on the timeline, select at least one type of alarm event and one initiator

4. Select the check box to display operator comments.
5. Click the **Apply** button.

Note.

To close Events Filter, click to same button again.

Selection of events is now complete.

Events of the selected type are now displayed on the timeline (see the section titled [The Timeline](#)) and in the events list (see the section titled [Events List](#)).

8.1.3.4 The Timeline

The timeline is a graphical representation of the time axis of the archive and is located in the middle part of the navigation panel.

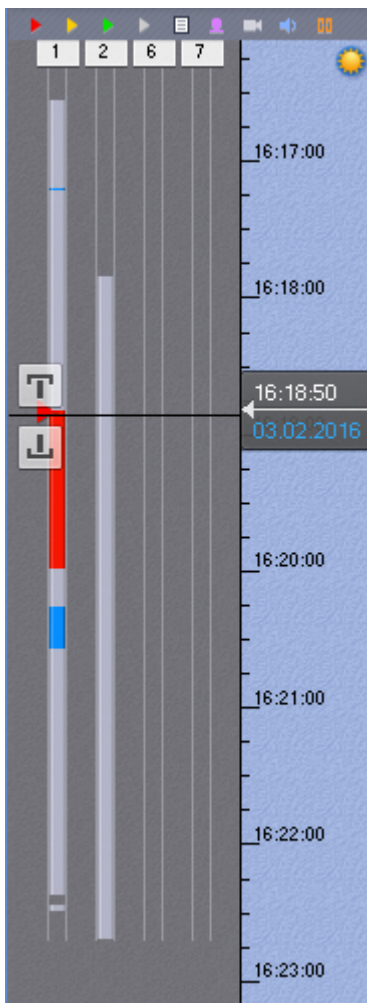

The timeline contains indicators of the presence of recordings, or tracks.

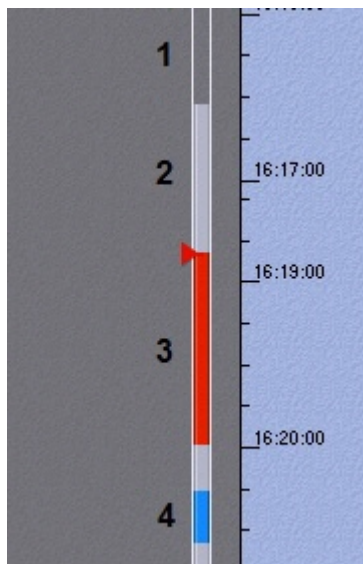

Tracks are marked in different colors depending on the alarm status or detection tool activation:

Condition	Track color
Archive absent (1)	Gray
Archive (2)	White
Archive present, alarm active (3)	Red
Archive present, detection tool activated (no alarm) (4)	Blue

Note

Pre-alarm recordings are white on the timeline, post-alarm footage is blue.

Note

If video recordings overlap or coincide in time, the available footage is prioritized as follows:

1. If there is recorded video, then red colored recordings have the highest priority and white ones have the least priority.
2. Grey footage takes priority over dark grey.

At the moment when an alarm is assigned a status (critical, non-critical, false, or unclassified), a flag is added to the track. A flag is added to the point on the timeline when the alarm began.

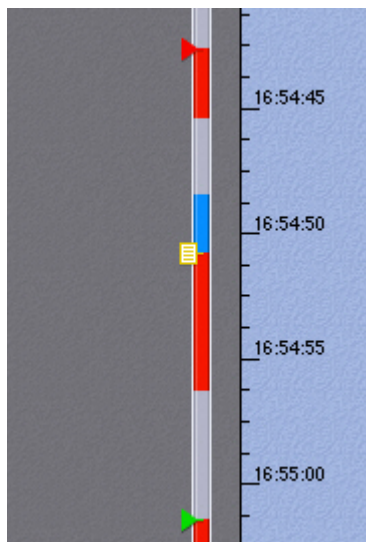

The flag is colored according to the alarm status:

1. Green – false alarm
2. Yellow – non-critical alarm
3. Red – critical alarm
4. Gray – unclassified alarm

Note

Display of any particular alarm event in the list is determined by filter settings (see the section titled [Events Filter](#)).

Operator comments are displayed with the corresponding icons on the track. An icon is placed on the timeline at the point corresponding to the commented frame (or to the first frame of the interval, if the comment is for an interval).

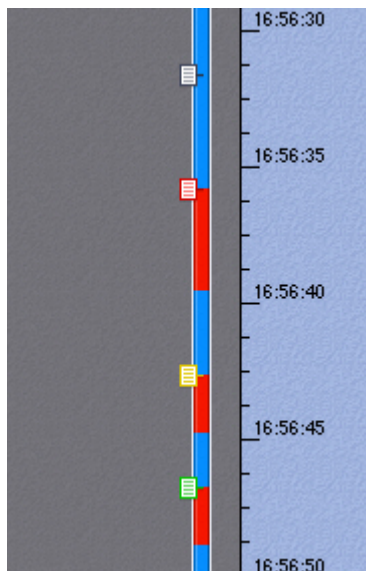

If comments were left during alarm classification, the icons are displayed in the appropriate colors.

You can scroll and zoom the timeline using the mouse.

To scroll the timeline, move the cursor on its background vertically while holding down the left mouse button. To change the scale of the timeline, right-click the timeline's background and, while holding down the right mouse button, move the cursor down to zoom out or up to zoom in.

The timeline lets you select at which moment to start playback of a recording in the viewing tile. To choose at which moment to begin playback, you can either left-click the indicator and hold it down while dragging it to the desired position, or just left-click the left portion of the timeline.

If there is no recording in the selected position, the indicator will automatically move to the position corresponding to the nearest recording.

Note

You can also set a timeline indicator in the desired position by indicating the exact date and time (see the section titled [Navigating Using the Timeline](#)).

You can also position the timeline indicator with the help of the events list (see the section [Events List](#)).

8.1.3.5 Events List

The Events List displays alarms and operator comments.

To display the events list, click the **Events** button.

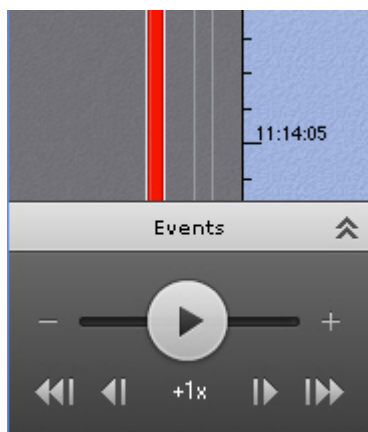

The events list is now displayed.

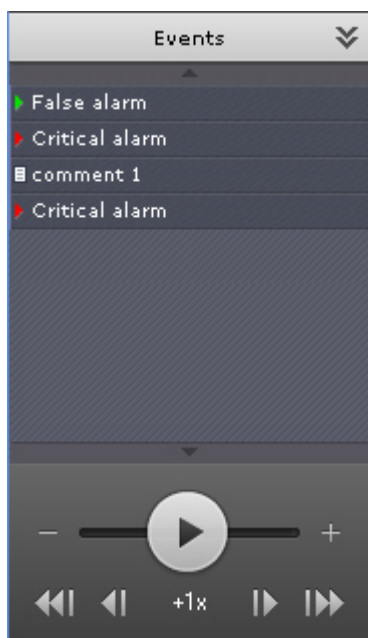

Note

Whether or not a particular event is displayed in the list depends on the filter settings (see the section [Events Filter](#)).

Note

The list displays only the alarm events that are currently in the visible portion of the timeline

To hide the events list, click the **Events** button again.

When you place the cursor over an event in the list, detailed event information appears.

**Note**



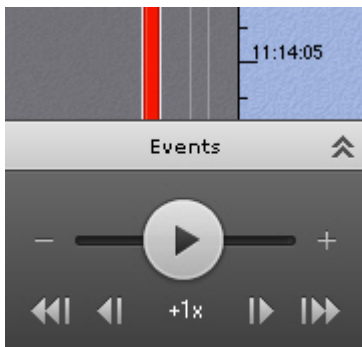

Navigation through the archive by using the events list is described in the section [Navigating Using the Events list](#)

8.1.3.6 The Playback Panel

The playback panel is located in the lower part of the navigation panel.



The playback panel contains the following buttons:

1.  Go to preceding frame.
2.  Go to next frame.
3.  Switches to the preceding recording.
4.  Switches to the next recording.
5.  Play/Pause.

The  button also acts as a slider which sets the speed and mode (forward/backward) of playback.

Note

Use of the playback panel is described in detail in the section [Navigating Using the Playback Panel](#).

8.1.4 Video Wall Panel

Configuring Video Wall

The Video Wall panel is automatically displayed at the top of the screen.

The panel is used to set up a video wall from all monitors currently connected to Axxon domain Servers on which video walls management is permitted for the given User (see [Creating and configuring roles](#)).



To keep the panel always visible, click the  button.

Note

To hide the panel, click the  button.

8.1.5 Monitor Panel

The Monitor panel is automatically displayed at the top of the screen.

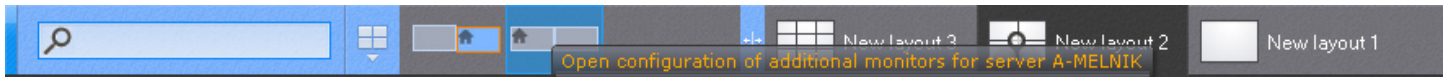

The panel shows thumbnail views of Client monitors currently connected to Axxon domain Servers on which video walls management is permitted for the given User (see [Creating and configuring roles](#)).

To open an expanded monitor view, click on its thumbnail.

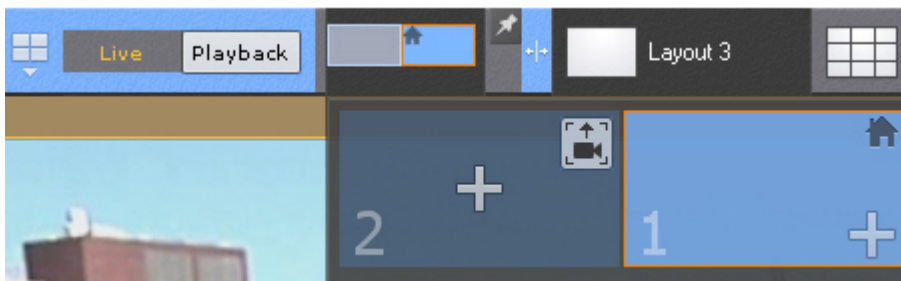

If you need to always display expanded monitor views, click .

Note.

To disable expanded views, click .

You can change width of the Monitor panel. To do it, click and drag the panel border .

When you resize the Monitor panel, the Layout panel is automatically changed.

8.1.6 The Layouts panel

The Layouts panel is automatically displayed at the top of the screen.

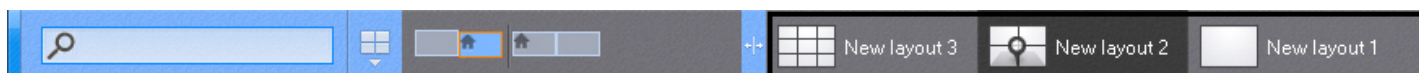

The panel shows layouts available in the system.

Note

If the client is connected to multiple Axxon domains, only layouts from the main Axxon domain are available.

[Layouts Management](#)

8.1.7 Interactive Map

The 3D interactive map is used to visualize the secured facility, control cameras and identify cameras' location.

Interactive maps in Axxon Next can obtain image data from graphics of the site or geospatial data from OpenStreetMap.

Note

To work with OpenStreetMap maps in *Axxon Next*, you need to purchase an [OpenStreetMap](#) license.

The map can contain icons for cameras, inputs, and outputs. The area in which live video is displayed and field of view are indicated for each camera.

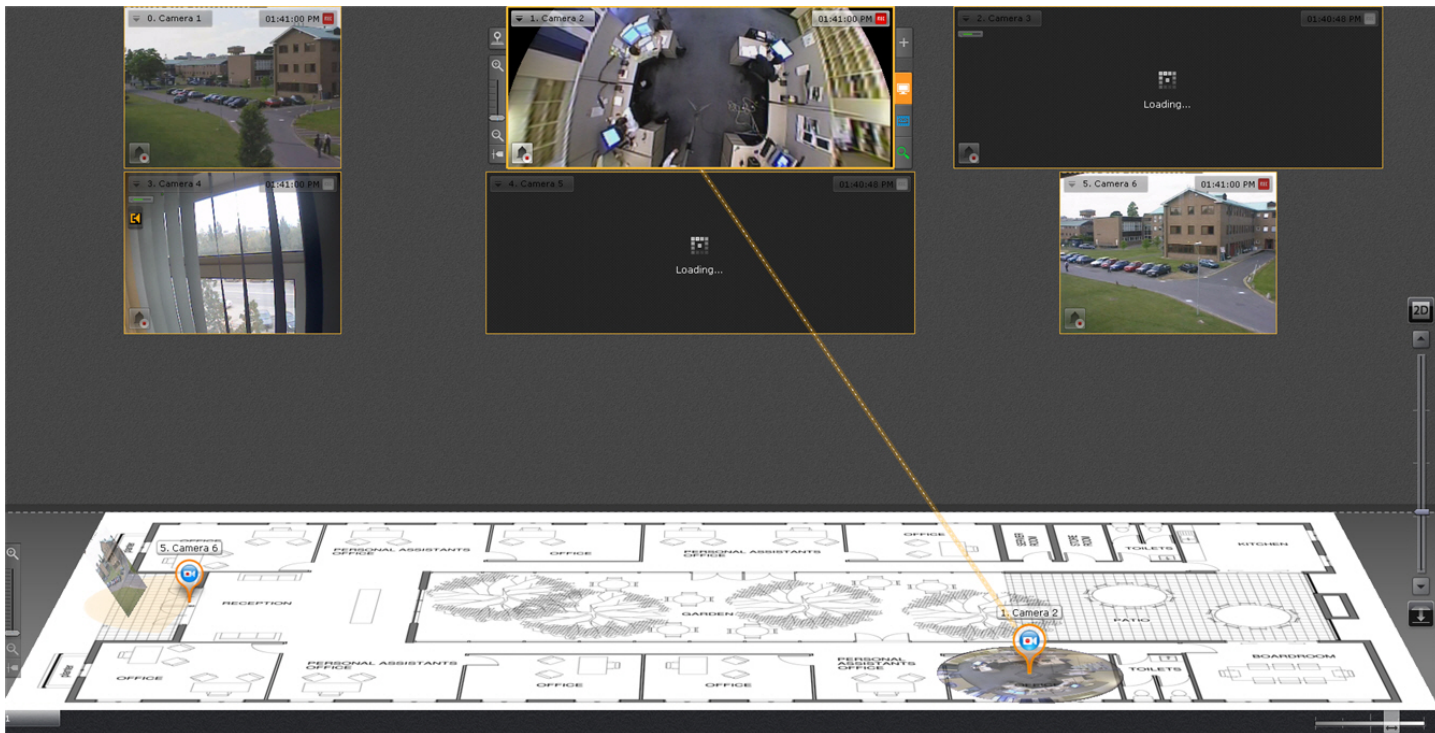

Please refer to the section titled [Working with the Interactive Map](#) for further details on how to work with the 3D map.

8.1.8 Camera Search Panel

The **Camera Search Panel** lists all video cameras connected to Axxon Next VMS. It also allows the user to find online cameras.

If you click the search bar (1), a dropdown (2) opens that lists all cameras within your Axxon domain.

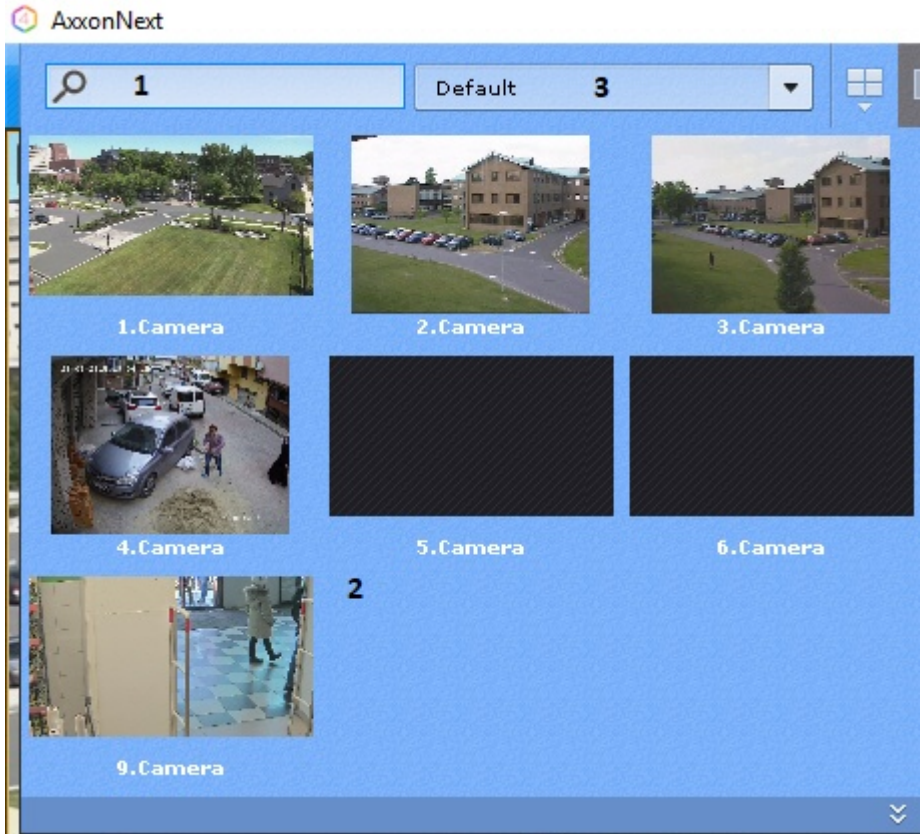

Note

If the client is connected to multiple Axxon domains, cameras from the main Axxon domain are listed by default. To find cameras from another Axxon domain, select the domain from the dropdown list (3).

To search for a specific camera, enter its full name or part of it into the search bar.

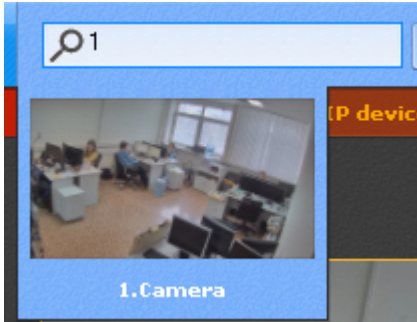

If you click a camera, a layout opens with the minimum number of cells for displaying the selected camera views.

Note

If the current layout contains the selected camera, the relevant viewing tile becomes active.

If there is no layout with the selected video camera, a new layout with a single cell is created.

To open the Objects Panel (see [Objects Panel](#)), click the



button.

8.1.9 Alarms Panel

Alarms Panel allows users to view and manage alerts / detection events.

Alarms Panel displays video footage for all alerts / detection events in individual Event Preview tiles.

Alarms Panel is at the top of the screen. The default setting is Auto Hide. To open Alarms Panel, click the  button.

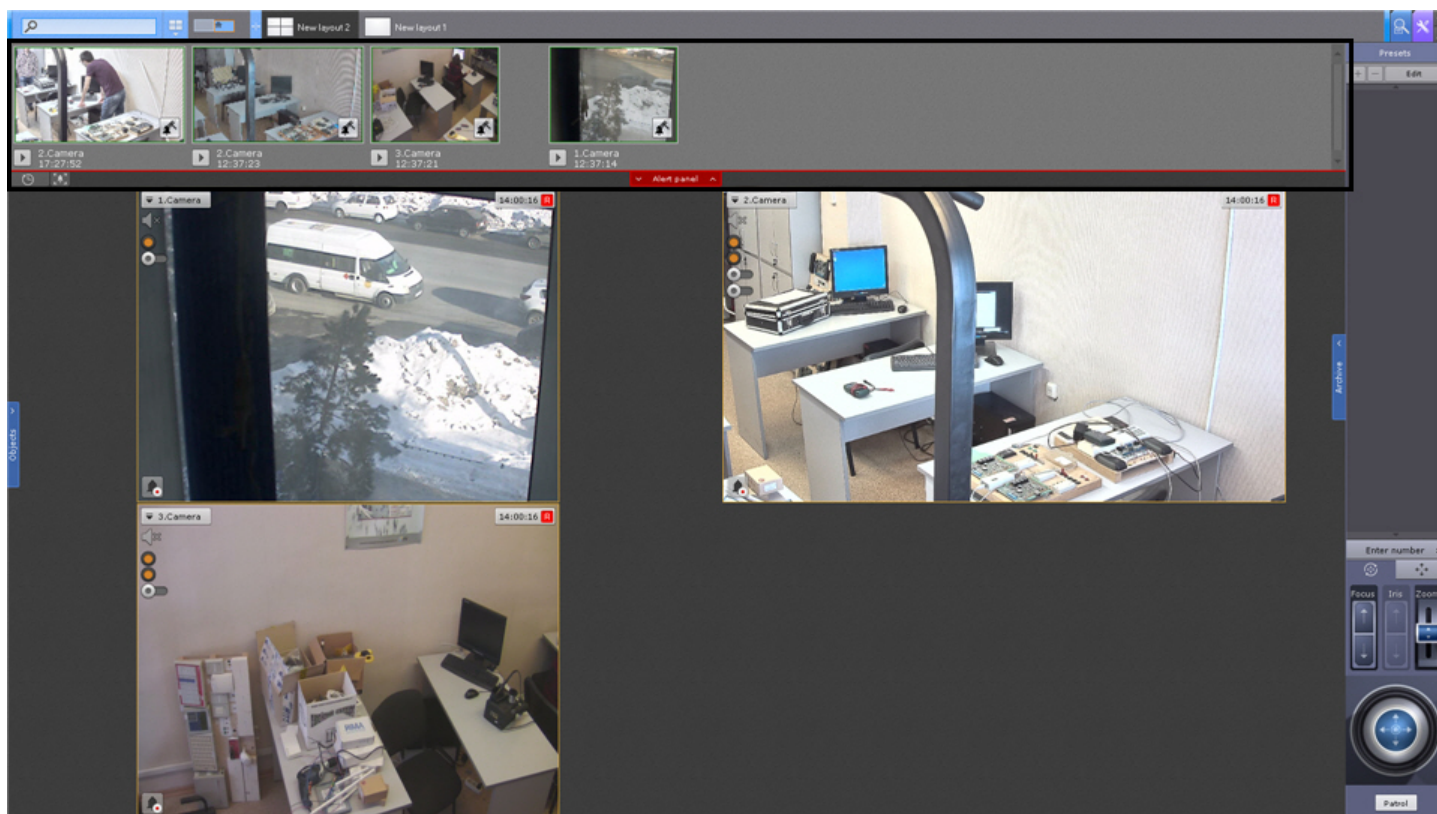

The panel opens downwards, occupying a vertical strip on the screen. You can stretch or shrink it from 10% to 50% of the screen height.

To resize the panel, left-click the Alarms button and hold and drag the pointer up or down.

You can also expand the panel to full screen. This will hide the camera views (layout). To do so, click the  button.

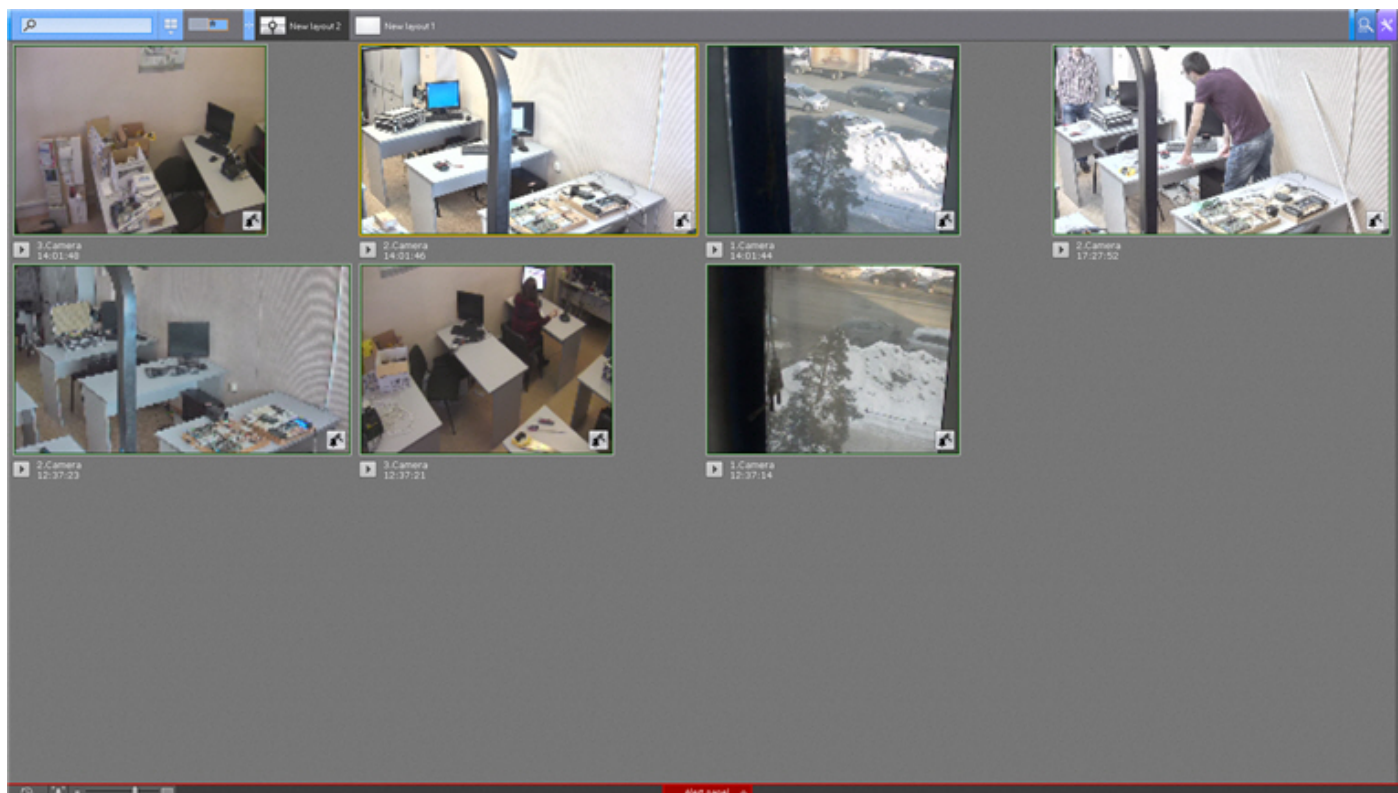

You can resize thumbnails of video fragments displayed on the panel.

You can do this when the size of the panel is exceeds the minimum size (10% of the screen height).

To resize Event Previews, use the slider in the bottom left corner of the panel - .

To hide the panel, click the  button.

8.1.10 Objects Panel

If you have permissions, Objects Panel displays cameras from all servers in the Axxon domain.

Note

If the Client is connected to multiple Axxon domains, you can see cameras from all Axxon domains according to your permissions.



To open this panel, click the  button in the upper left corner of the screen.

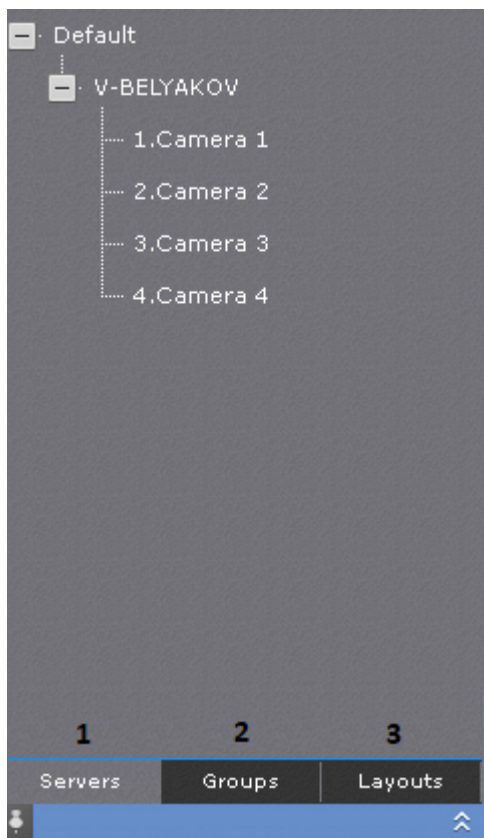

Note

On Object Panel, the cameras can be sorted either by name or by a short name (see [Configuring camera sorting on Object Panel](#)).

The object tree on the panel can be represented as Servers (**1**), Groups (**2**) and Layouts (**3**).

If you select a camera on the panel, a layout opens with the minimum number of cells for displaying the selected camera views (see [Camera Search Panel](#)).

Note

The search results are displayed in the Objects Panel dynamically — as users type and refine their queries.

To lock the panel, click the



button in its bottom left corner. Press the



button to unlock the panel.

You can resize the Objects Panel according to your needs. To do this, left-click and drag the right border of the panel.

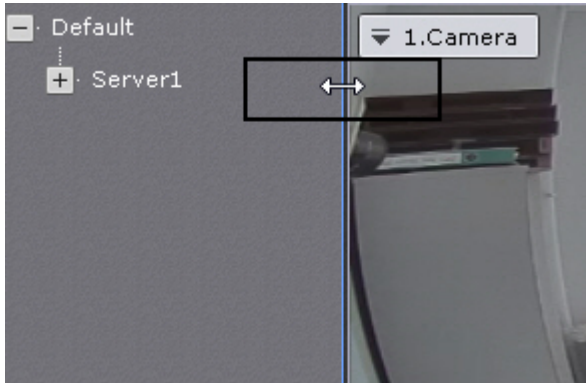

To hide the panel, click the button.

8.1.11 The PTZ Control Panel

The PTZ control panel is displayed automatically in the right-hand part of the screen when the viewing tile of a PTZ camera is activated in Live Video mode.

Note

The PTZ control panel is displayed only if the **PTZ** object for the particular video camera is enabled (see the section titled [The PTZ Object](#)).

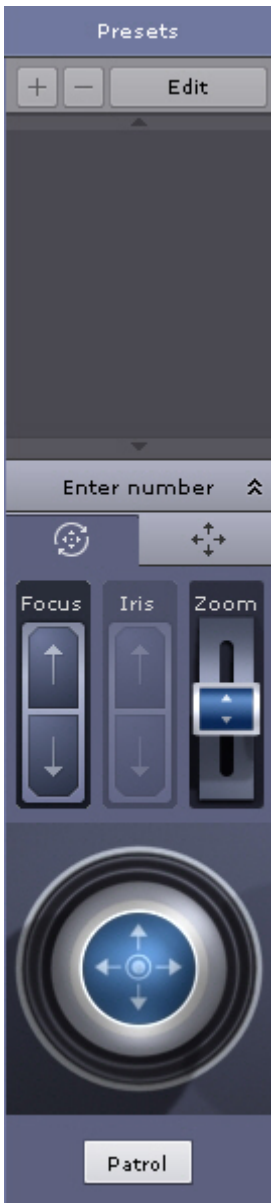

The PTZ control panel is used for the following functions:

1. Controlling PTZ video cameras.
2. Setting and switching to camera presets.
3. Launching/stopping PTZ tours.
4. Launching/stopping patrolling.

The PTZ control panel includes the following interface elements:

1. Presets list.
2. PTZ tours list.
3. Dialer
4. PTZ controls for iris, focus, and optical zoom

Note

If a camera does not support a function, the controls for this function cannot be accessed

5. Virtual 3D joystick

Note

The type of virtual 3D joystick and adjustment scale depend on the type of PTZ cameras: discrete or continuous control of Pan, Tilt, Zoom, Focus, and Iris.



6. Patrol button

Note

Use of the dialer, PTZ controls, joystick, and patrol button is described in the section [Controlling a PTZ Camera](#).

8.1.12 Story board

The Story board becomes available after you set a time interval on the timeline (see [Standard video export](#)).

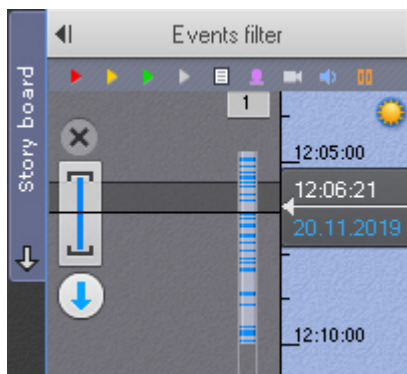

To open the board, click the corresponding button.

In the Story board, you can check all videos related to an incident to export them with one click (see [Exporting all event videos](#)).



To hide the board, click once more the **Story board** button.

8.2 Video Surveillance

8.2.1 Video Surveillance Modes

The video image from a video camera is displayed on the computer monitor through the Client's interface objects, namely the video surveillance monitor and the viewing tile.

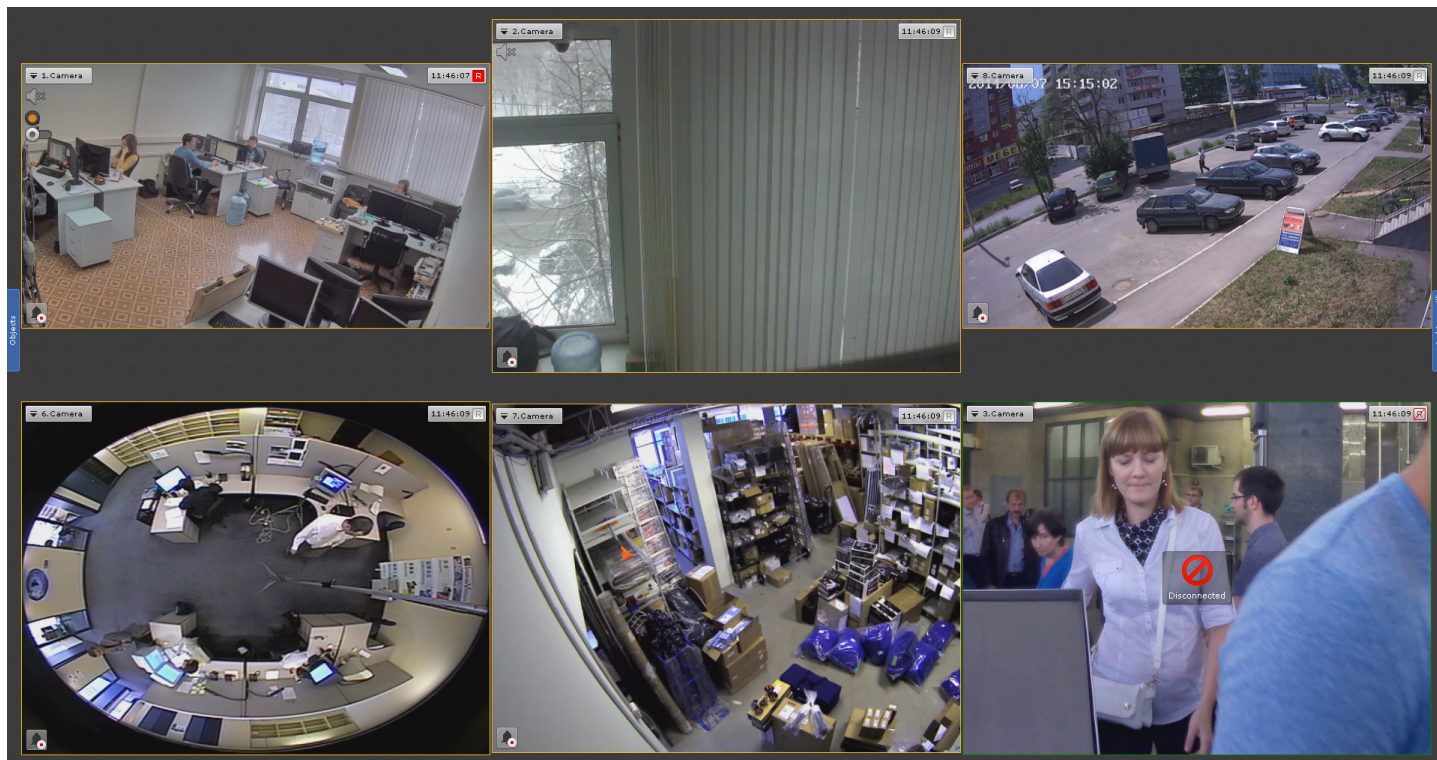

There are four modes for working with a viewing tile:

1. Live Video mode
2. Alarm Management mode
3. Archive mode
4. Archive Search mode

Note

Alarm Management mode is available if an alarm has been initiated in the system.

8.2.2 Functions Available in All Video Surveillance Modes

The following video surveillance functions are available in all video surveillance modes:

1. Selecting a video camera.
2. Scaling the viewing tile.
3. Digitally zooming video images.
4. Processing video images.
5. Rotating video Images.
6. Tracking objects.
7. Operator comments.
8. Viewing titles from POS terminals.
9. Partial decoding of video.

8.2.2.1 Scaling the Viewing Tile



The scale of the viewing tile can be adjusted.

This can be done in one of three ways:

1. Using the buttons in the upper right-hand part of the active viewing tile.
2. Using the buttons in the top panel.
3. Using the mouse.

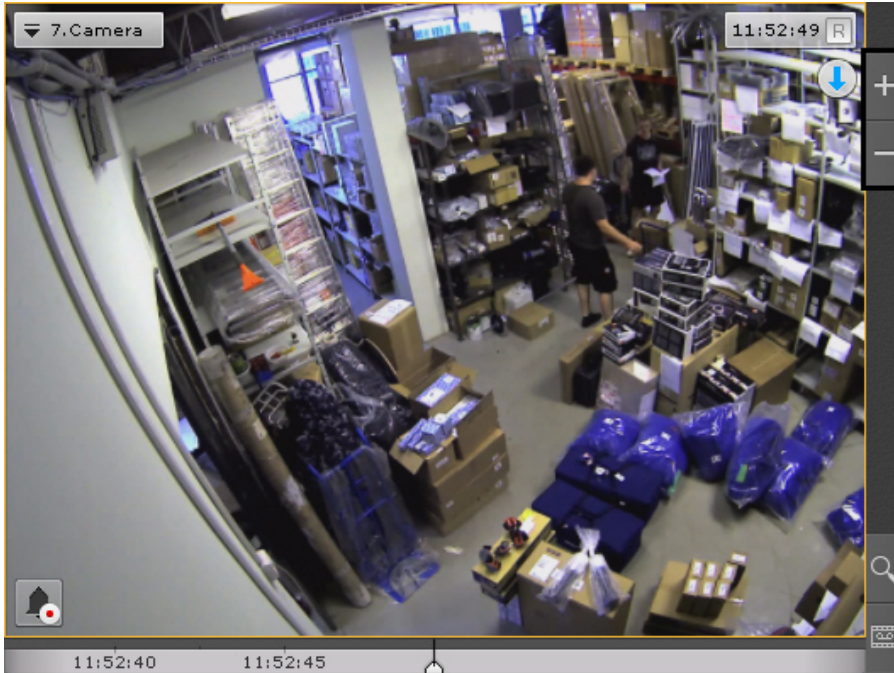
If you click a viewing tile, you can see size control buttons on the right-hand side.



1.  — increases the size of the viewing tile by one step;
2.  — resets the size of the viewing tile.

When a viewing tile is enlarged, the scale of the entire layout is increased. Some of the cells are moved off the screen.

Viewing tiles are enlarged as follows:

1. If a viewing tile occupies 100% of any of the sides of the layout (maximum viewing tile size), it cannot be enlarged.
2. If a viewing tile occupies 50% or more (but not 100%) of any of the sides of the layout, it is enlarged as much as possible.
3. If a viewing tile occupies less than 50% on both sides of the layout, it is enlarged in two steps: the first step enlarges the viewing tile to 50% on the corresponding side of the layout and the second step enlarges the viewing tile to the maximum size.

Note

The third case applies to layouts that contain nine or more cells



If a viewing tile is linked to another one or an information board, at the first enlargement step (to 50%), the viewing tile and the other tile / information board are displayed together and occupy all of the screen on one side.

Note

In this case, the first step takes into account the total size of the related cells: the related cells must be less than 50% of both sides of the layout

Also, if you click a viewing tile, you can control its size with the buttons on the top panel:



1.  - Resets the size of the viewing tile.
2.  - Resizes the tile up to 50% on one side of the layout.
3.  - Maximizes the size of the viewing tile.

How to resize the camera window using a mouse:

1. In full screen mode, click anywhere to minimize the window.
2. Otherwise, double click inside the window to display it in full screen mode.

8.2.2.2 Digitally Zooming Video Images

Digital zooming in a video image enables a gradual increase in the magnification of a video image without changing the dimensions of the viewing tile.

The video image can be enlarged using the following tools:

1. Digital zoom scale
2. Area selection
3. Mouse scroll wheel

8.2.2.2.1 Enlarging a video image using the digital zoom scale

To display the digital zoom scale on the viewing tile screen, select **Show digital zoom** in the context menu of the viewing tile.

Displaying the zoom control:

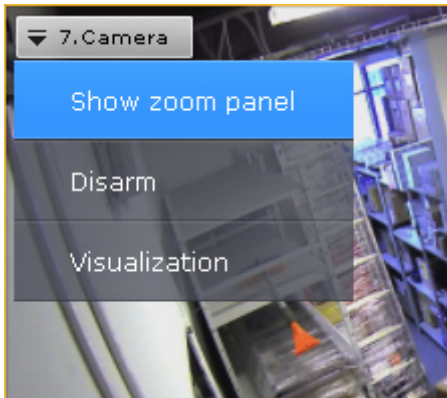

Digital zoom scale:



To enlarge a video image, left-click the slider and hold and drag the digital zoom scale up to the desired value. The maximum zoom is 16x. To return back to the original image, move the slider back to its original position.

To hide the digital zoom scale, select **Hide digital zoom** in the context menu of the viewing tile. Also, 3 seconds after you scale down the video image to the minimum, the zoom scale will automatically hide.



After hiding the digital zoom scale, the selected zoom level of the image will be preserved when switching between image viewing modes.

8.2.2.2.2 Enlarging a video image through area selection

To enlarge a video image, select the area of the image that you would like to enlarge.

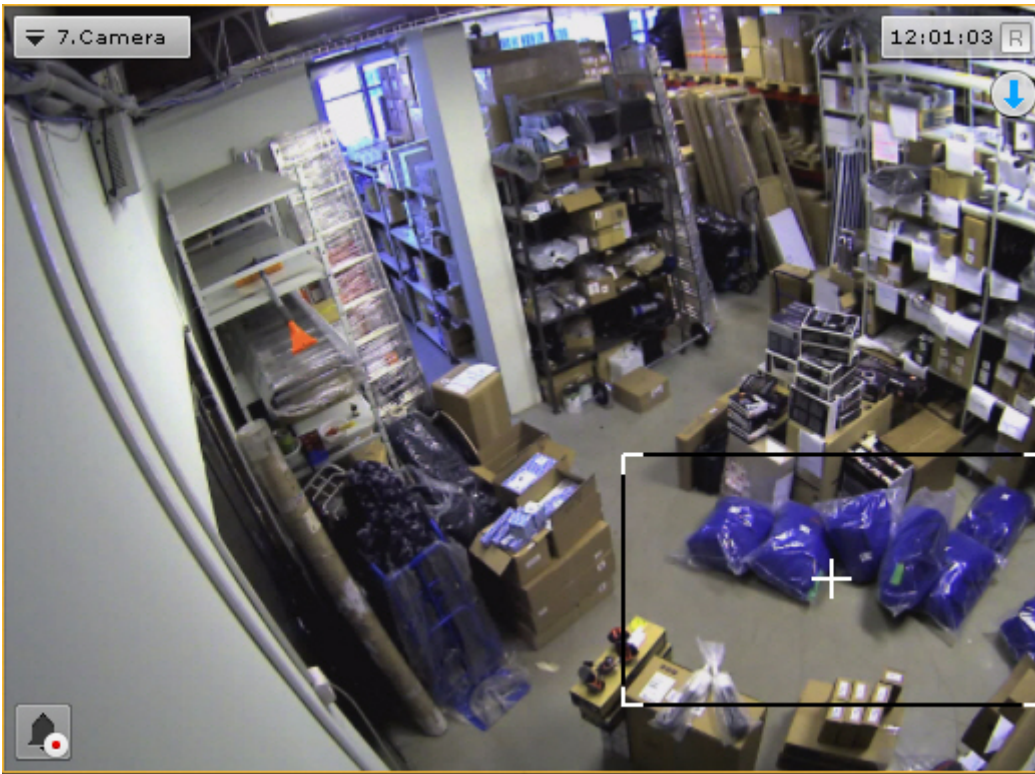

You can select an area by doing the following:

1. Click and hold down the left mouse button inside the viewing tile.
2. Move the mouse cursor to the desired position.
3. Release the left mouse button.

Once you have completed the above actions, the selected area will be displayed across the entire viewing tile.



Note

If you select an area that requires a zoom of more than 16x to display, it will be marked with a red frame. The video image will not be enlarged.



8.2.2.3 Enlarging a video image using the mouse scroll wheel

When using the mouse scroll wheel, the video image is enlarged relative to the mouse cursor. A description of this process is provided in the table below.

Action	Executed function
Mouse wheel is scrolled forward by one level	The video image is enlarged by 2x
Mouse wheel is scrolled backward by one level	The video image is reduced by 2x

8.2.2.3 Video image processing

In *Axxon Next*, the video image processing functions implemented in the viewing tile enhance the performance and convenience of using the video surveillance system.

The following video image processing functions are available from the viewing tile:

1. Contrast
2. Sharpness
3. Deinterlacing

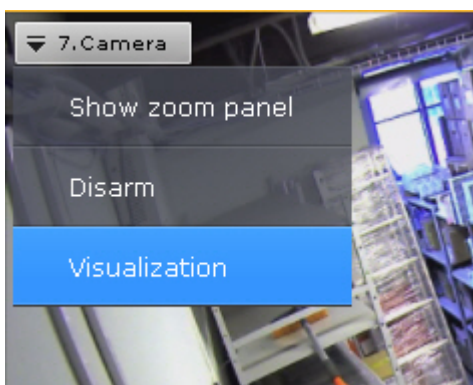

To enable video image processing functions, use the **Visualization** option in the context menu of the viewing tile. Only one image processing function can be enabled at a time.

8.2.2.3.1 Changing the Contrast Level

An *Axxon Next* operator is granted access to adjust the contrast of a video image.

To adjust the contrast, select the **Contrast** option in the **Visualization** context menu.

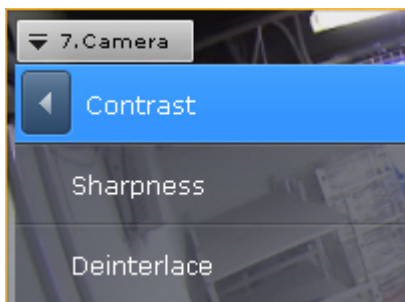

An example of the **Contrast** function is given in the following image.



To return to the original image, reselect the **Contrast** option in the **Visualization** context menu.

8.2.2.3.2 Setting the Sharpness Level

An Axxon Next operator is granted access to adjust the sharpness of a video image.

To adjust the sharpness, select the **Sharpness** option in the **Visualization** context menu.



The image in the following picture shows an example of use of the **Sharpness** tool.

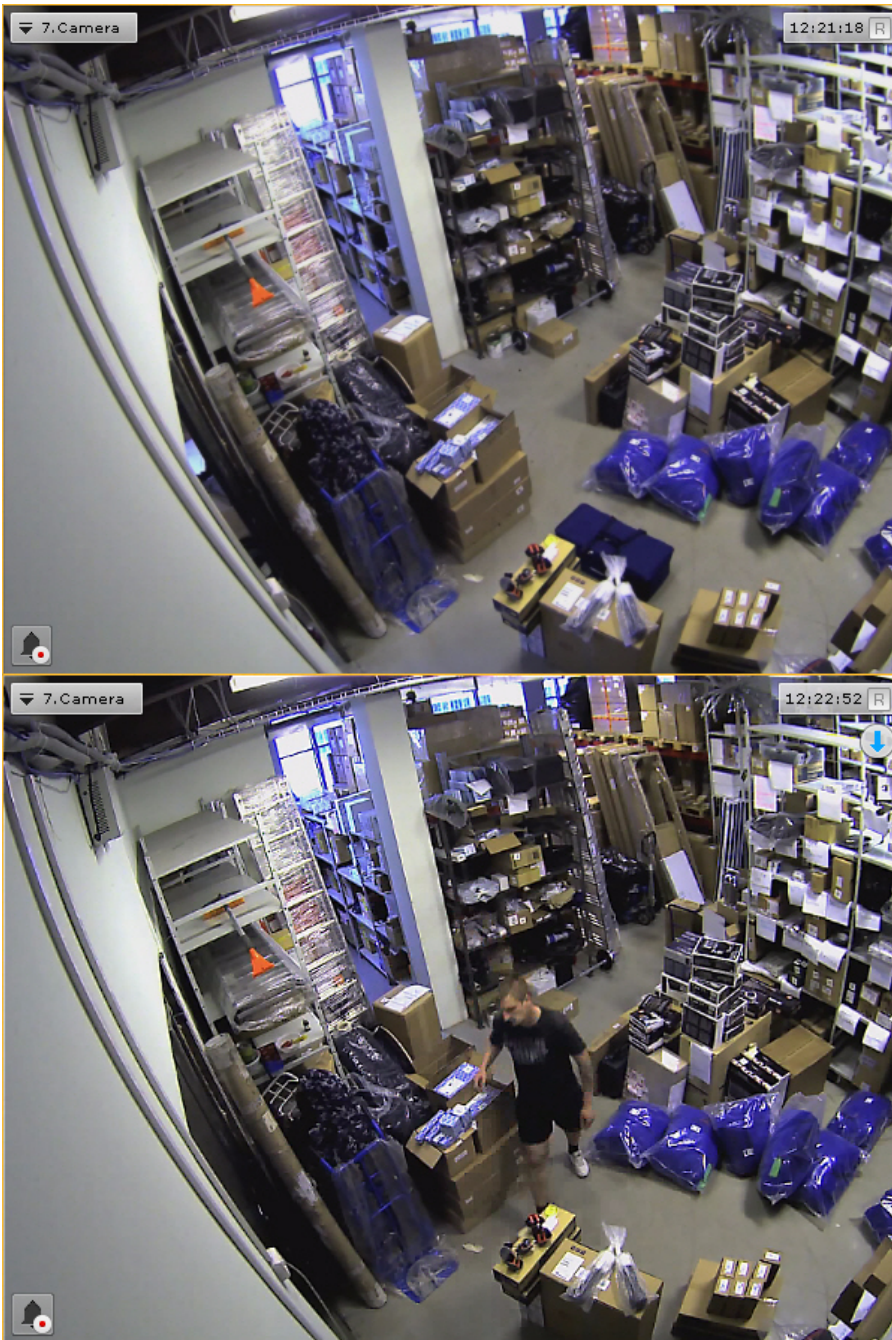

To return to the original image, use the **Sharpness** function again.

8.2.2.3.3 Using Deinterlacing

The **Deinterlacing** tool is used to correct tooth-type distortions (also called "combing artifacts"), which appear on the borders of video image fragments when objects move quickly relative to the background.

An example of a combing artifact is shown in the picture below.



To utilize this tool, select the **Deinterlace** option in the **Visualization** context menu.

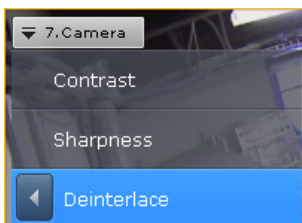

The image in the viewing tile will then be corrected.



To disable **Deinterlacing**, reselect the **Deinterlace** option.

8.2.2.4 Rotate Video Image

You can rotate a video 90°, 180° or 270° degrees.

Note

If you enable video rotation, only video in Live Video and Archive modes is rotated:

- NA (not applicable) for video display on the map and on the alarms.
- NA to recording for archives.
- NA for export.
- NA for analytics (metadata).

To rotate video, complete the following steps:

1. In the viewing tile context menu, select **Visualization**.

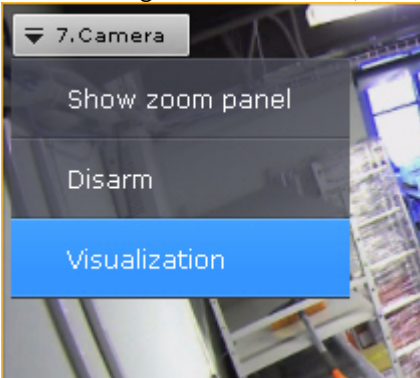

2. Select the angle of rotation (clockwise).

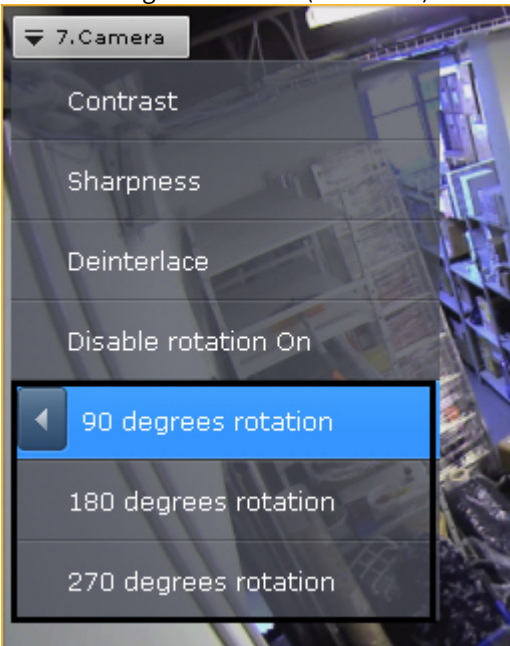

Video rotation is now complete.

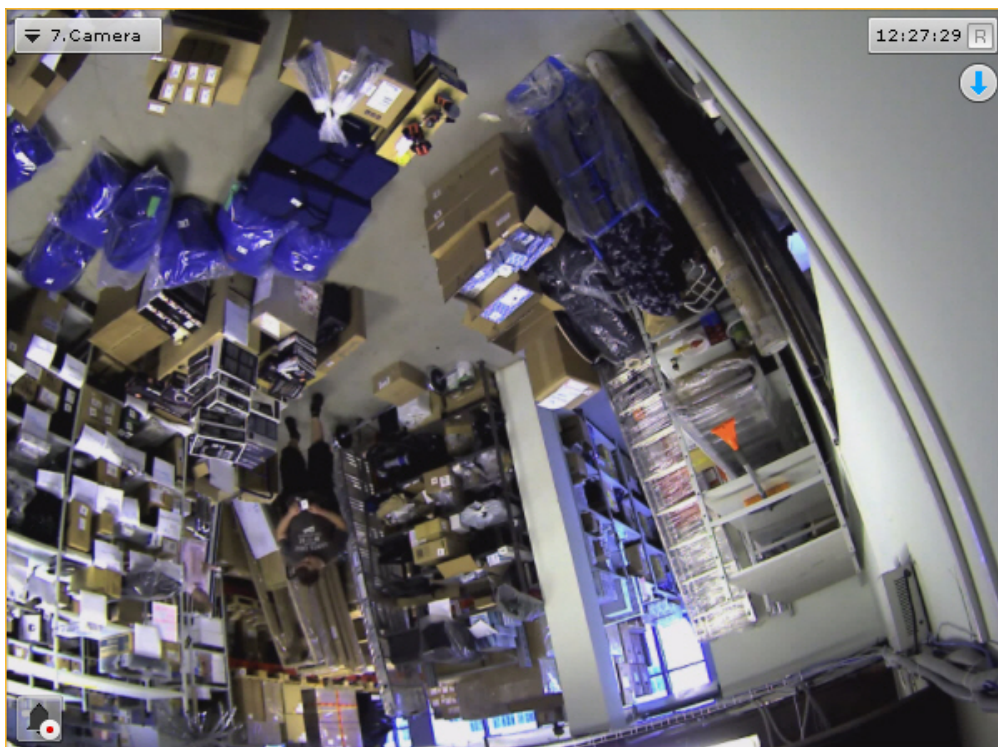

To disable video rotation, select **Visualization**-> **Disable rotation** in the viewing tile context menu.



8.2.2.5 Tracking objects

Object tracking allows a user to visually track the movement of objects in a camera's field of view or in a video recording in an archive.

Attention!

Object Tracking is available if:

1. the object tracker is activated for this camera (see [General information on Scene Analytics](#));
2. the Video Motion Detection tool is activated (see [Configuring VMD](#));
3. at least one of the Embedded Analytic tools is activated (see [Embedded Detection Tools](#)).

Object tracking performs the following functions:

1. Recognizes the presence of a moving object and dynamically marks it with a transparent rectangle on the video image.
2. Displays the trajectory of the object's movement.

Motion is detected based on the time gradient of the video image's difference between frames.

To enable object tracking, select **Show tracking** in the viewing tile context menu.

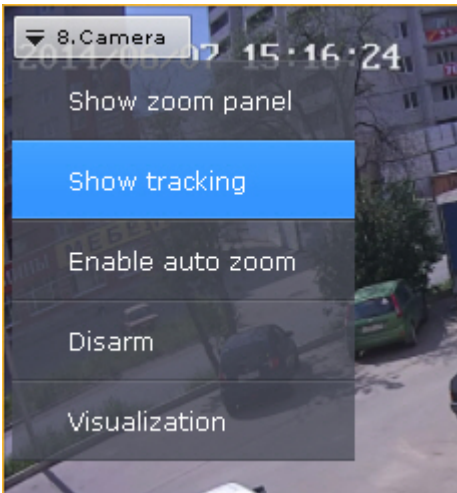

Object tracking functions will now be activated.

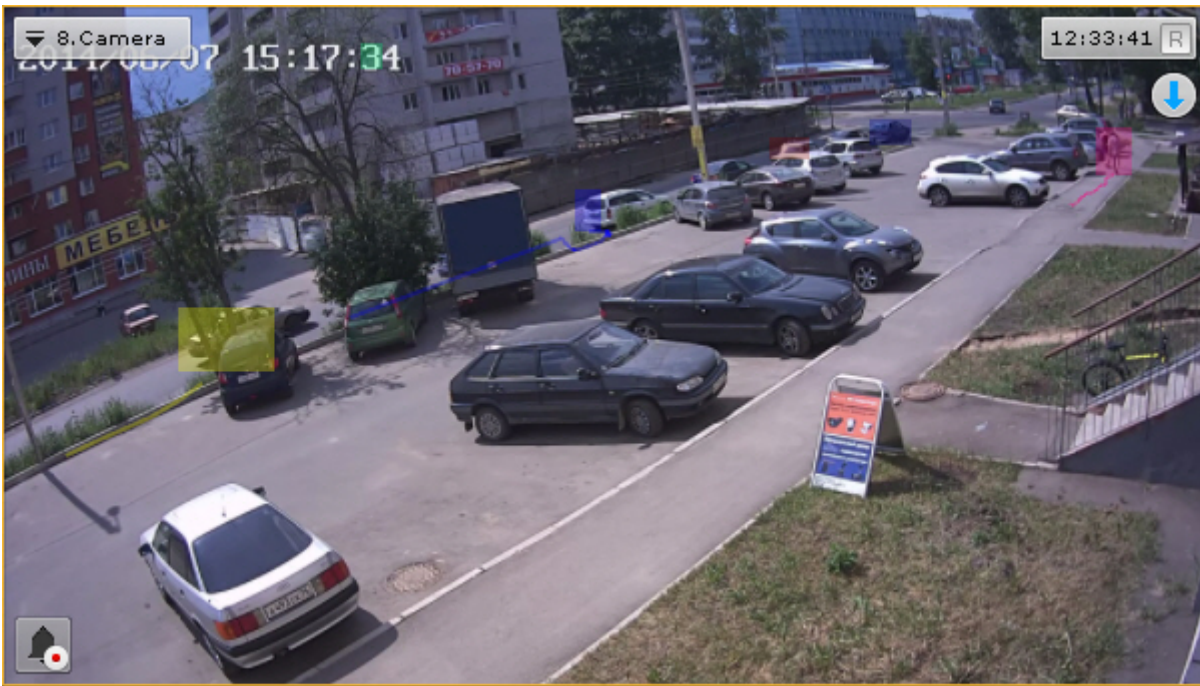

To disable object tracking, click **Hide tracking** in the viewing tile context menu..

If you have created a situation analysis tool for this video camera (see [Functions of Scene Analytics](#)), then you can see the detection parameters (areas, lines) in Live Video mode along with object tracking in the camera window.

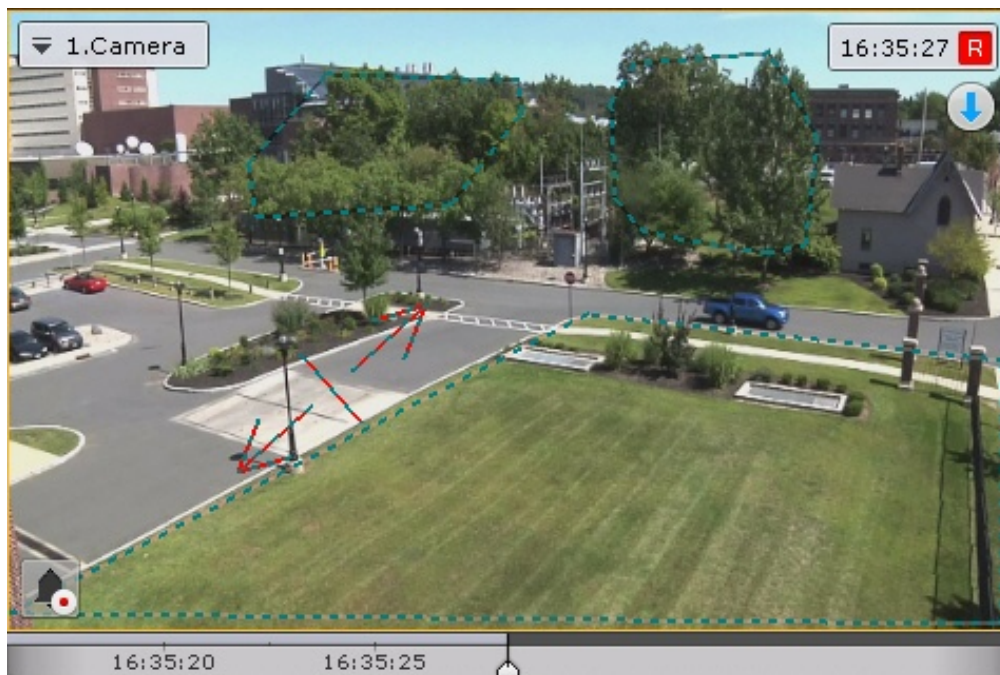

Note

Areas to be excluded from surveillance are outlined in dotted black and green line while detection areas are outlined in black and gray.

If an ANPR detection tool has been created for a camera, the license plates within the video image will be outlined (see [Automatic Number Plate Recognition \(LPR/ANPR\) tools](#)).

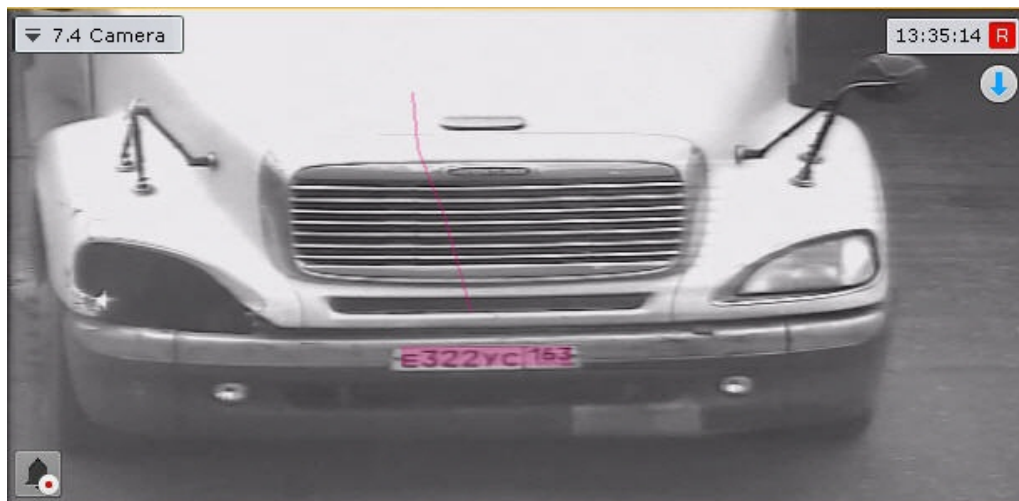

Attention!

To ensure correct display of the outline, set the camera's **Video Buffering** parameter with the range of 500–1000 (see [The Video Camera Object](#)).

If a face detection tool has been created for a camera, all faces within the video image will be outlined.



If a pose detection tool (see [Configure Pose Detection](#)) has been created for a camera, a human skeleton is highlighted over the video image.

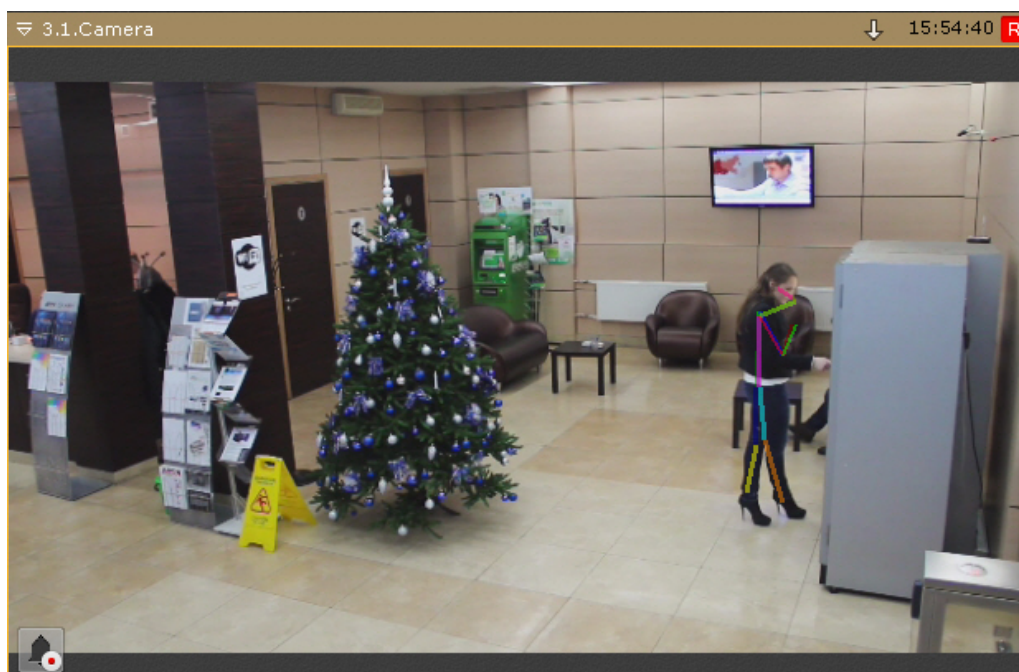

8.2.2.6 Operator comments

Operator comments on past or ongoing events allow a more complete understanding about the situation at the site.

Comments are displayed during playback (see [Viewing recorded video with operator comments](#)) and are marked with tags on the timeline (see [The Timeline](#)). Comments can also be searched (see [Searching comments](#)).

8.2.2.6.1 Adding comments in different surveillance modes

In Archive and Archive Analysis modes, comments can be added both for specific frames and for intervals of time.

To add a comment for an interval, select an interval on the timeline, place the timeline indicator either inside the interval or at one border of it, and click the  button.

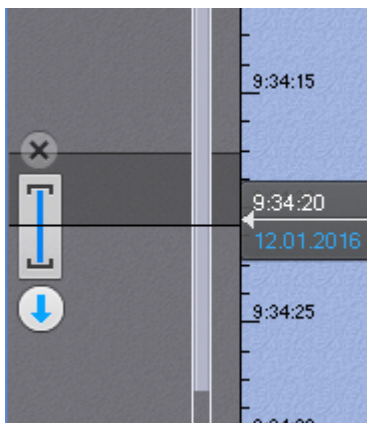

Note

If comments are added during playback in Archive or Archive Analysis mode, playback is paused after the  button is clicked.

In Alarm Management mode, operators can be required to give comments after classifying an event (see [Configuring Alarm Management Mode](#)) or comments can be left in free form, before event classification, by clicking the  button. The comment applies to the entire duration of the alarm.

8.2.2.6.2 Adding a comment



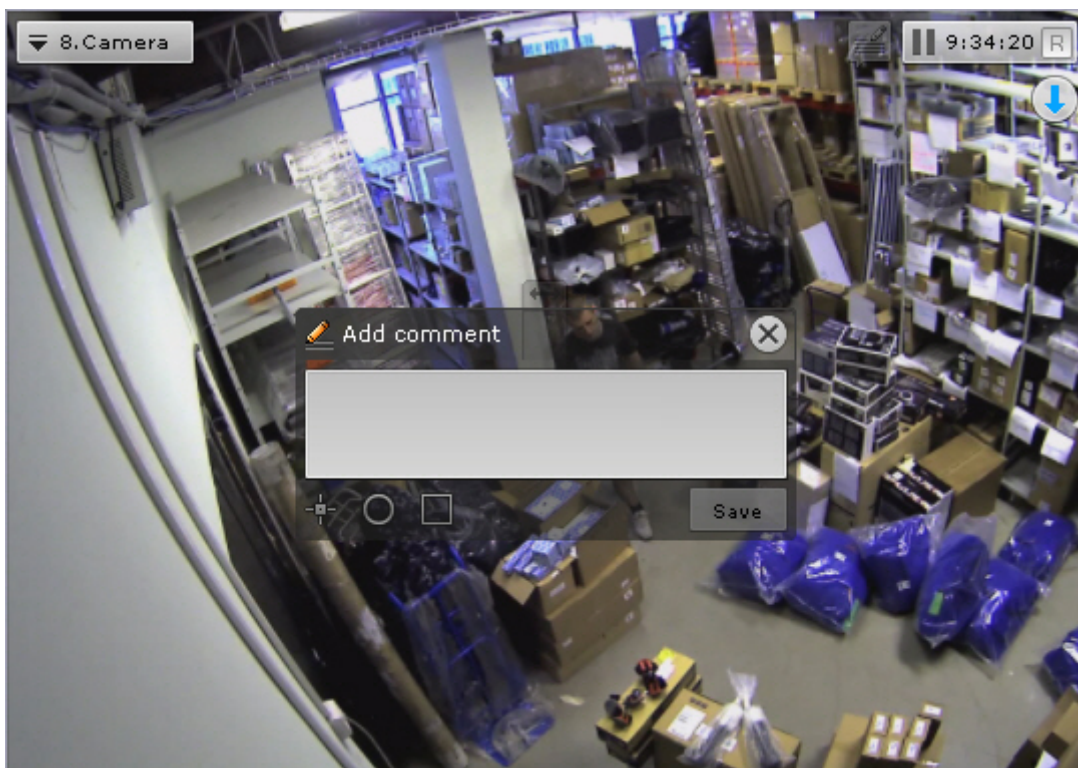

To add a comment, click the  button. A dialog box opens for entering a comment.



The number of characters in the comment is limited.

The following parameters can be configured:

1. Position of comment in the frame (the window with the comment is movable by dragging the window title).

2. Transparency of comment window, by adjusting the  slider from left to right (from opaque to maximum transparency).
3. Marking the area of interest in the frame, with a dot () , semicircle () , or rectangle (). To do so:
1. Click the relevant button and then click anywhere in the frame. The selected element is displayed.

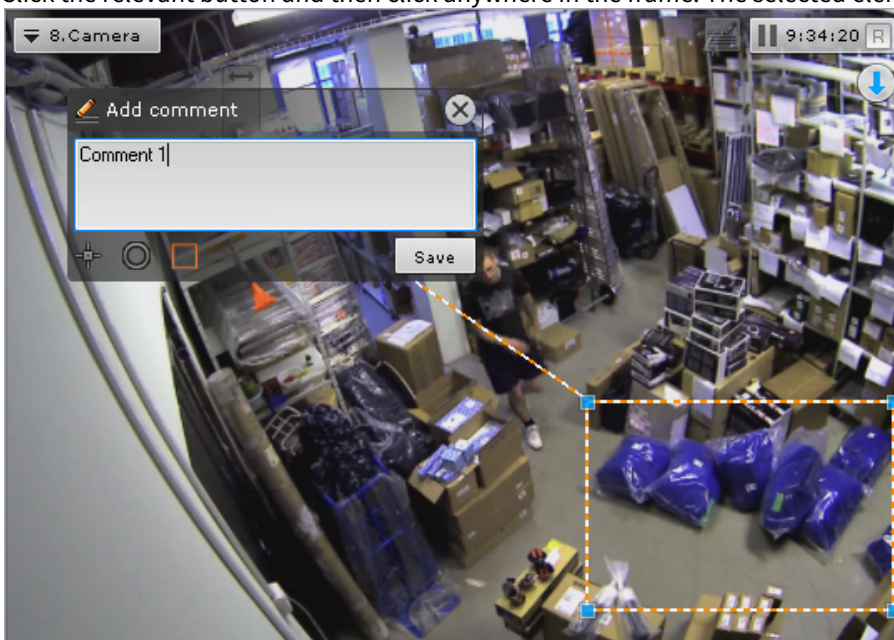

2. Drag the element to the necessary place in the frame. To do so, left-click and drag the edge of the area (or for a dot, click and drag the dot).
3. Set the size by dragging the corner points.

To save the comment, click the **Save** button. Otherwise, click  to cancel.

After being saved, a comment is displayed in the frame as specified. To delete the comment, before you perform any other command in the system, click the  button..

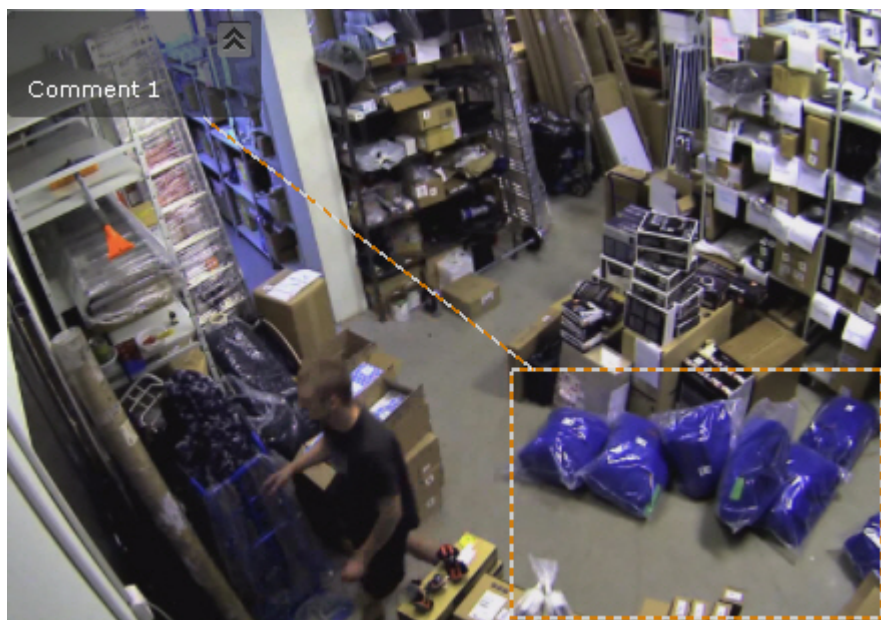

8.2.2.7 Viewing titles from POS terminals

If you have configured the titles overlay, the video tiles show titles superimposed on video (see [Configuring titles view](#)).

You can have titles from several POS terminals in the same camera window.

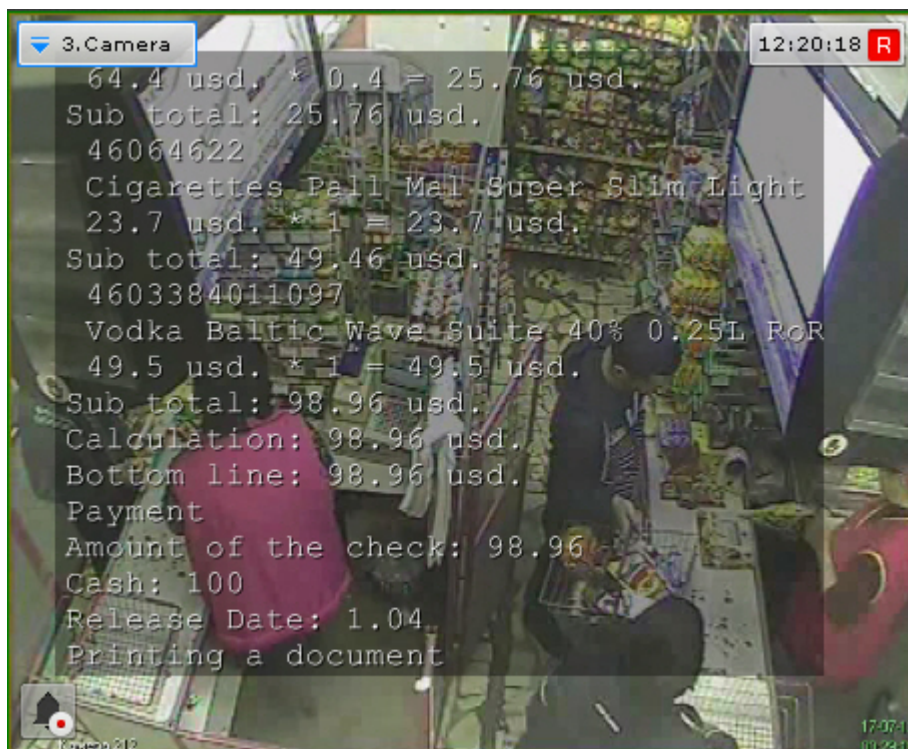

Note

Keywords or lines can be highlighted according to the settings (see [Configuring keywords](#)).

If you view recorded video, titles are synced by time.

Note

With certain captions' output settings (the **Duration** parameter = 0, see [Configuring titles view](#)) and low-intensity events at the checkout, you may have a time lag between the captions displayed and the video time stamp.

To disable titles overlay, select **Event Sources** in the context menu of the viewing tile and a POS terminal that you want to hide.

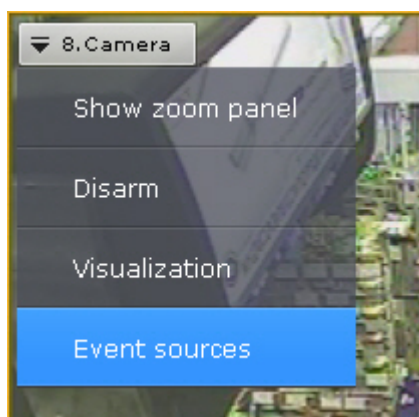

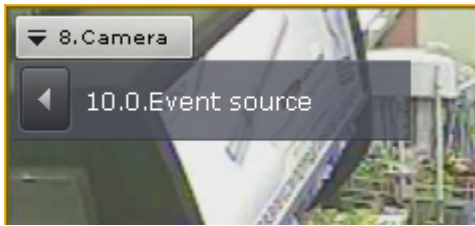

8.2.2.8 Partial decoding of video

Video encoding / compression is a digital video processing technique aimed at reducing the bit rate of streamed video and bandwidth consumption. Video is compressed according to a specific software algorithm - codec.

To compress video signals from IP-devices, standard codecs such as MPEG-4 or vendors' proprietary codecs are used.

Before displaying the compressed video signal on screen, it is automatically decompressed.

If the resolution of a viewing tile is lower than that of compressed video, only part of the video stream is decoded. This reduces CPU load on Axon Next clients. Partial decoding does not affect bandwidth requirements. Partial decoding works with MPEG-2, MJPEG and MxPEG.

8.2.3 Real-time video surveillance

8.2.3.1 Switching to Live Video Mode

To switch the Camera Window from a different surveillance mode to Live Video viewing mode, click the **Live** tab in the lower-right corner.

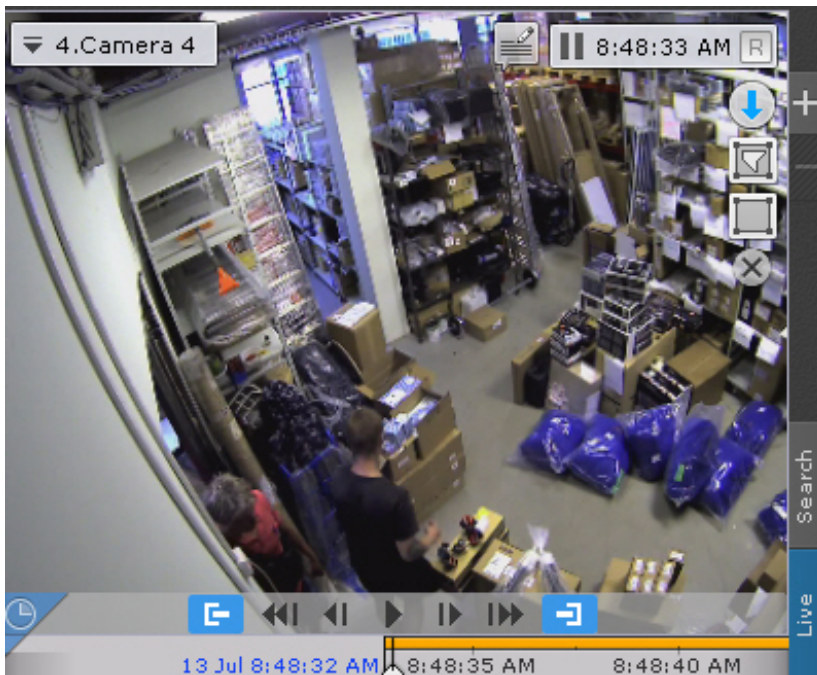

The viewing tile will then appear in Live Video mode.



8.2.3.2 Video Surveillance Functions Available in Live Video Mode

In Live Video mode, the following video surveillance functions are accessible:

1. Selecting video stream quality in a viewing tile.
2. Autozoom.
3. Functions for tracking of moving objects.
4. Arming/disarming a video camera.
5. Controlling a PTZ Camera.
6. Controlling outputs.
7. Displaying the input status.
8. Autoreplace offline cameras on layouts.
9. Snapshot.
10. [Functions Available in All Video Surveillance Modes.](#)

8.2.3.3 Arming and Disarming a Video Camera

In *Axxon Next*, a video camera is armed via all the detection tools registered for that video camera.

To arm a camera, select one of the following two parameters in the context menu of the viewing tile:

1. **Arm (1)**. In this case, the camera will be available to all users who have access to it.
2. **Arm in private mode (2)**. In this case, the camera will not be available to the users with the **Live in Armed mode**.

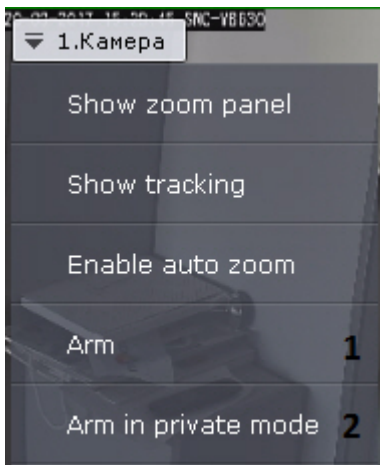

To disarm a camera, select **Disarm** in the context menu of the viewing tile. The video camera will then be disarmed.

8.2.3.4 Controlling a PTZ Camera

PTZ video camera can be controlled with the PTZ Control Panel or directly in the Viewing Tile (see [Controlling a PTZ Video Camera in the OnScreen PTZ Mode](#), [Control using Areazoom](#), [Control using Point&Click](#)).

The user gains access to this panel when the viewing tile of a video camera in Live Video mode that supports a PTZ control interface is selected.

Attention!

PTZ camera is controlled in accordance with the priority settings (see [Creating and configuring roles](#)). If multiple users have the same control priority, they can control a PTZ camera simultaneously.

If the user with higher priority controls the PTZ camera with the the PTZ control panel (as long as the camera is selected) users with a lower priority can not control it. If the user with higher priority controls the PTZ camera, the relevant information is displayed on the panel.



If you disabled the option to simultaneously control a PTZ camera by multiple users, users with the same priority take over the control on a first-come, first-served basis.

However, a user with equal or higher priority can take over the PTZ control. To do this, click the **Take Control** button.

If the user that controls the PTZ camera is idle a certain time (see [Configuring PTZ control](#)), it is automatically unlocked and the control becomes available to all users.

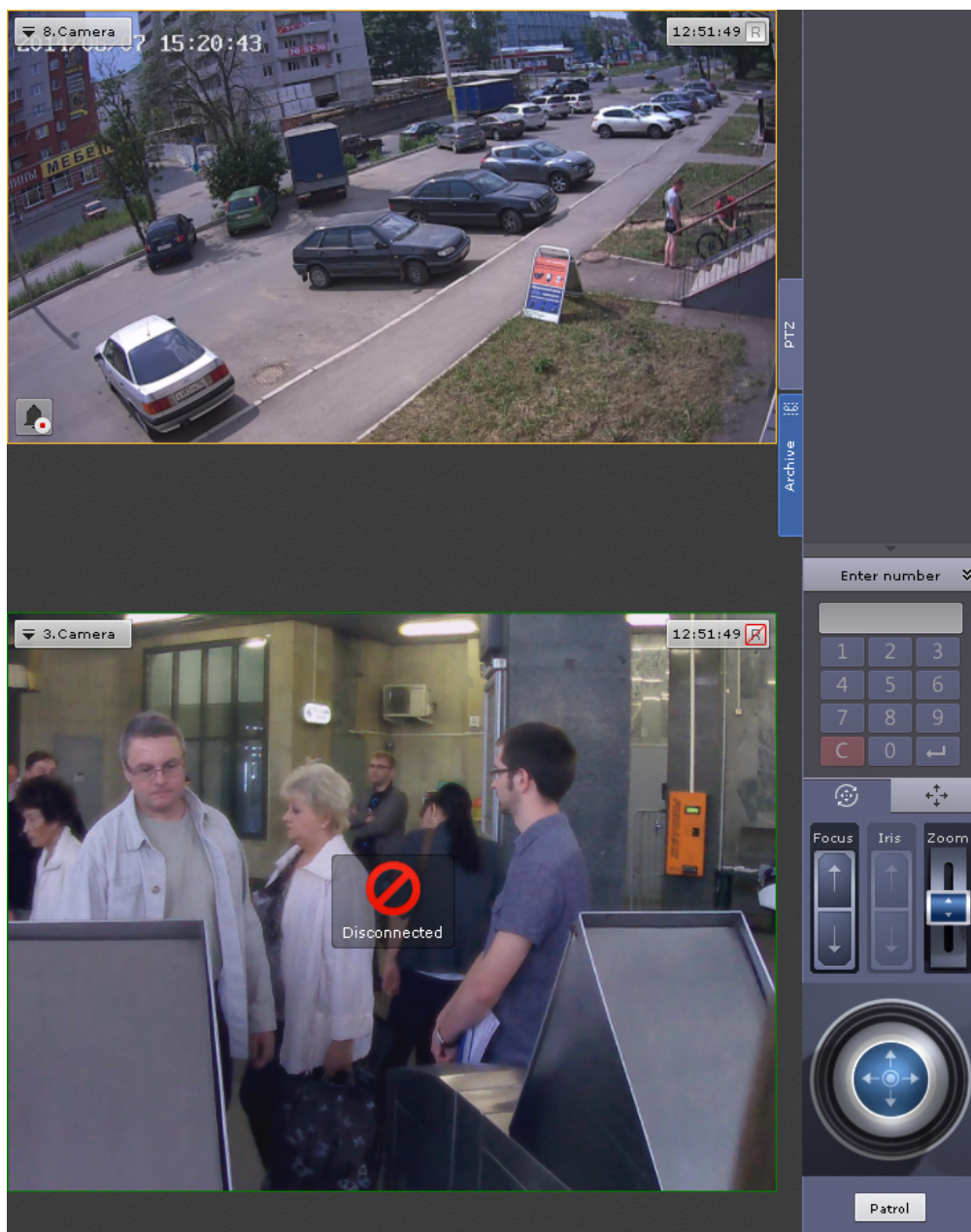

The following actions can be performed using the PTZ device control panel:

1. Use presets.
2. Modify the parameters of the iris, focus, and optical zoom.
3. Modify the horizontal and vertical tilt angle of the video camera.
4. Starting/stopping patrol mode.

Note

Setting presets is described in detail in the section [The PTZ Control Panel](#).

8.2.3.4.1 Presets

8.2.3.4.1.1 Creating and editing presets

The presets list created for a selected video camera is displayed in the upper part of the PTZ control panel in the  tab.



For each preset in the list, the following parameters are displayed:

1. The identification number
2. A descriptive name

The presets list is used for the following functions:

1. Creating presets.
2. Editing the identification number and name of an existing preset.
3. Deleting presets.
4. Switching to a preset.

You can create up to 100 presets with numbers from 0 to 99. To create a preset, you must perform the following steps:

1. Place the PTZ camera in the position which is to be saved as a preset.
2. Click . Fields for entering an identification number and a descriptive name for the preset will then appear.



3. Fill in these fields as desired.

Attention!

If a preset with the identification number entered already exists, its parameters, as well as the corresponding PTZ camera position, will be overwritten.

4. Left-click anywhere in the presets list and press Enter to save changes.

Creation of a preset is now complete.

To edit the number and name of an existing preset, you must perform the following steps:

1. Highlight the desired preset in the list.
2. Click . The identification number and descriptive name fields will then become accessible for editing.
3. Modify the preset number and/or name as desired.
4. Left-click anywhere in the presets list to save changes.

Editing of the preset is now complete.

To delete an existing preset, you must perform the following steps:

1. Highlight the desired preset in the list.
2. Click .

The preset has now been deleted.

To switch to a preset, left-click the corresponding line in the presets list. The camera will then be switched to the desired position.

Note

See the section [Selecting a preset](#).

8.2.3.4.1.2 Selecting a preset

To switch a PTZ camera to a preset, you can use the presets list. To do this, left-click the corresponding line in the given presets list.



To switch a PTZ camera to a preset, you can use the Enter number panel. To display the Enter number panel, click the **Enter number** button.



To switch to a preset using the Enter number panel, you must perform the following steps:

1. Using the numeric buttons (0-9), enter the number of the preset to which you want to switch. The entered number is displayed in a special field.

To delete the last digit entered, click the  button.





2. Click the  button to switch to the preset with the number entered. The camera will then be switched to the desired position.

Switching to a preset using the Enter number panel is now complete.

Note

Examples of entering a number:

5,  – Switch to preset number 5;

0, 5,  – Switch to preset number 5.

5, 7,  – Switch to preset number 57.

8.2.3.4.2 PTZ Tours

During a PTZ tour, the camera automatically scrolls between pre-listed preset positions.

Attention!

In Axxon Next, you can set up PTZ tours only for cameras connected via the ONVIF Generic driver (see [Generic Drivers \(General device, generic\)](#)).

The presets list created for a selected video camera is displayed in the upper part of the PTZ control panel in the  tab.



8.2.3.4.2.1 Creating and editing PTZ tours

Axxon Next automatically adds PTZ tours created with the camera's web interface.



To add a new tour, do the following:

1. Click the  button.
2. Enter a name of the new tour, and click the **OK** button.

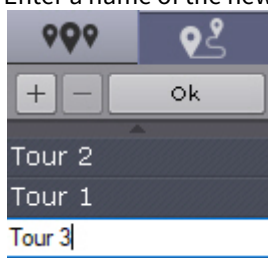

3. Select the tour's first preset (1).

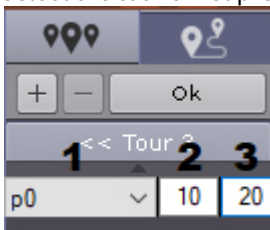

4. Specify dwelling time in seconds for this preset (2).
5. Specify transition speed to this preset in standard units from 1 to 100 (3).

Attention!

This parameter is reserved for future Axxon Next software versions.

6. Click the **OK** button.
7. Add all other desired presets in the same way.
8. Click  to return to the PTZ tours list.

To alter a tour, select it in the list and click **Edit**.



To delete a tour, select it and click .

8.2.3.4.2 Launching a PTZ tour

To start a tour, do the following:

1. Select a tour from the list.



2. Click the **Patrol** button.

To stop a tour, click again the **Patrol** button.

8.2.3.4.3 Control using step buttons and virtual joystick

To control a PTZ camera, you can use both step buttons (discrete PTZ mode) and the virtual joystick (the camera must support continuous PTZ), if the camera supports both modes.



To select, click the  and  buttons.

Otherwise, only one of the modes may be used.

Note

If your camera is set to Discrete PTZ Control via Continuous, your control options will be limited to buttons only (see [The PTZ Object](#)).

Set the sensitivity level of PTZ step buttons by selecting a value from 1 to 10.



If you press and hold the buttons, the PTZ camera will move continuously.

Attention!

Interaction between PTZ cameras and the Client may cause the cameras to jerk in some cases.

Cameras also may jerk when they are connected by the Onvif protocol (see [Notes on configuring video cameras connected via ONVIF](#)).

Virtual joysticks are controlled as follows:

1. Click and hold down the left mouse button in the central (blue) portion of the joystick.
2. Drag the joystick in the necessary direction.

Note

You can also move the joystick by clicking and holding the left mouse button outside of the joystick border.

The turn speed depends on the tilt of the joystick: the greater the tilt, the higher the speed.

Note

If you rotate a camera view / viewing tile 180°, you will have PTZ controls inverted.

8.2.3.4.4 Patrolling

Patrolling is an automatic change in the position of a camera along a route defined in the camera's presets list.

Note

You can use a cycle macro to set up patrolling (PTZ camera tour, see [Switch to a PTZ camera preset](#), [Wait for timeout](#), [Cyclical macros](#)).

Patrolling must be activated in camera settings (see [The PTZ Object](#)). In this case, the operator can stop patrolling by clicking the **Patrolling** button on the PTZ control panel. After the manual PTZ control session is over, patrolling will resume automatically.

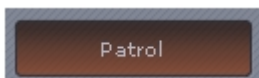

If patrolling is switched off in camera settings, you can switch it on by clicking the **Patrolling** button.

Attention!

Manual control takes priority over automatic control. Any interference in the patrolling process cancels it.

To stop patrolling, click the **Patrol** button again.

Note

Any user (regardless of priority, see [Creating and configuring roles](#)) can stop patrolling

Patrolling will automatically stop when a manual PTZ control session is over, or after you close the PTZ control panel.

Note

Control session automatically stops after a set idle time (see [Configuring PTZ control](#)).

8.2.3.4.5 Controlling Focus, Iris and Optical Zoom

To control focus, iris and optical zoom, use the corresponding sliders.



To control focus, iris, and optical zoom, move the corresponding slider up or down.

If the camera has AF (auto focus), you can see the corresponding  button under the slider.



Some devices allow to control optical zoom with the mouse scroll wheel.

To control optical zoom with the mouse, go to **OnScreen PTZ** mode (see [Controlling a PTZ Video Camera in the OnScreen PTZ Mode](#)), otherwise the zooming will be digital (see [Digitally Zooming Video Images](#)).

8.2.3.4.6 Controlling a PTZ Video Camera in the OnScreen PTZ Mode

The **OnScreen PTZ** mode enables controlling a PTZ video camera by mouse manipulations in the Viewing Tile.

Click  to enable this mode

Note

In **OnScreen PTZ** mode, the Areazoom function is disabled (see [Control using Areazoom](#)).

To change the viewing angle, click on a video image with the left mouse button and move the mouse pointer in the required direction. During this action the software displays a visual element on the image showing the camera lens movement direction and speed.

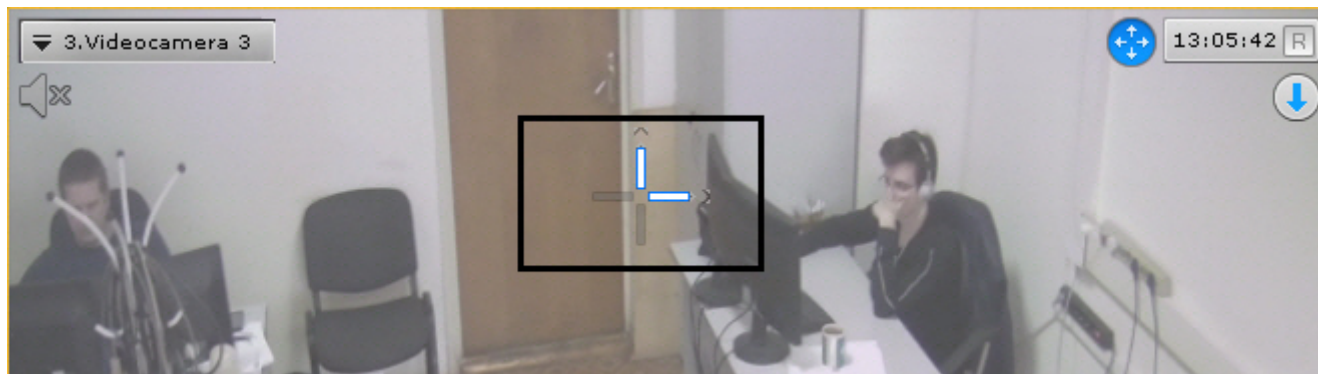

The faster you move the mouse, the faster the camera rotation will be.

Click  again to disable the **OnScreen PTZ** mode.

8.2.3.4.7 Control using Point&Click

To change the focus of the camera lens, left-click anywhere within the video image in the viewing tile.

Attention!

To operate Point&Click, go to **OnScreen PTZ** mode (see [Controlling a PTZ Video Camera in the OnScreen PTZ Mode](#)).

Once you have done that, the focus of the camera lens will automatically change to the selected area. The focus is changed using *Axxon Next* algorithms.

Note

This function is available for only some CCTV cameras.
For more information, contact AxxonSoft.

8.2.3.4.8 Control using Areazoom

You can focus on a particular area in a video frame.

Note

Areazoom function is unavailable if the **OnScreen PTZ** mode is enabled (see [Controlling a PTZ Video Camera in the OnScreen PTZ Mode](#)).

To do so:

1. Click a point to focus on it.



2. Holding down the mouse button, moving outward from the center of the focus area, the user sets the size of the area. Releasing the mouse button finalizes the selection.

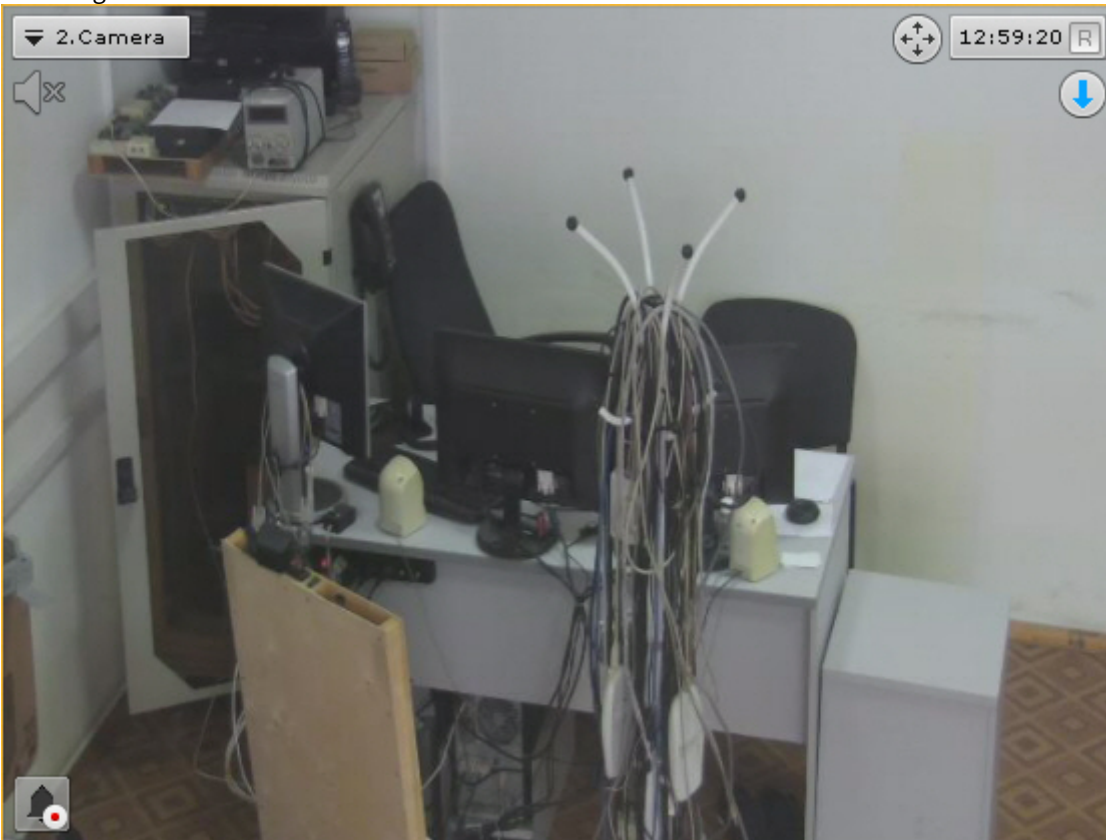

The lens is reoriented and the image is enlarged so that the selected area now fills the entire viewing tile.

Note

This function is available for only some CCTV cameras.
For more information, contact AxxonSoft.

8.2.3.5 Functions for tracking of moving objects

Axxon Next includes several features for tracking moving objects.

With Tag & Track, an object can be tracked by a PTZ camera under the guidance of panoramic cameras.

With Tag & Track Lite, the operator is alerted to the camera in front of which the moving object is most likely to appear next. The camera is predicted based on object trajectory and mapping of cameras to map locations.

8.2.3.5.1 Tag & Track Pro

Tag & Track functionality depends on the PTZ mode that is specified in the settings.

Attention!

To use Tag & Track Pro, make sure your PTZ camera supports Absolute Positioning. The devices that support Tag & Track Pro are listed in the [Drivers Pack documentation](#).

When connecting via the ONVIF protocol, Absolute Positioning support is also required. Contact camera vendor for information on the Absolute Positioning support in the ONVIF protocol.

Attention!

If manual or control priority mode is selected, for Tag & Track Pro you must activate object tracking in the viewing tile of the overview camera (see the [Tracking objects](#) section).

- If automatic mode is selected, the PTZ camera will track all active objects. In this case the PTZ camera switches focus between each object with the specified dwell time.

Note

The PTZ camera is positioned so that the moving object is in the center of the frame.

- In manual mode, the PTZ camera tracks an object only after the object is manually selected in the viewing tile (left-click to track). If you click anywhere in overview camera's FOV that contains no tracks, the PTZ camera cancels object tracking and focuses on the specified point.



- If control priority mode is selected, the PTZ camera automatically tracks an object until another object is manually selected for tracking in the viewing tile. If an object is deselected (by clicking again) or if it leaves the field of view of the PTZ camera, automatic mode is re-activated.

- If the PTZ camera is in manual mode, the user controls it with on screen or with a joystick / CCTV keyboard. If the user does not operate the PTZ camera ([Control panel](#) hidden), then the Automatic mode is used.

Note

Tag & Trac Pro cannot be used with the OnScreen PTZ mode simultaneously (see [Controlling a PTZ Video Camera in the OnScreen PTZ Mode](#)).

8.2.3.5.2 Tag & Track Lite

Attention!

For Tag & Track Lite to work, you must activate object tracking in the viewing tile (see the [Tracking objects](#) section).

Tag & Track Lite works as follows:

1. The operator left-clicks an object to start tracking it (the object is outlined with a white frame).



2. After the selected object leaves the field of view of the camera, the video camera's location on the map and trajectory of the object are used to predict the camera in front of which the object is **likely to appear**.
3. The viewing tile of that camera is activated. If the current layout does not contain that camera, a minimal layout with the camera is shown.

Note.

If the viewing tile for that camera is currently in archive mode, the tile is switched to Live Video mode and made active.

Note.

If video in the viewing tile of the original camera is magnified and the predicted camera is not in the layout, the viewing tile with the camera is made active and the same degree of digital zoom is applied.

Attention!

Tag & Track Lite merely predicts, and therefore cannot guarantee, that the object will appear in front of a given camera.

4. To continue tracking the object, select it again in the camera window.

8.2.3.5.3 Simultaneously using Tag & Track Pro and Tag & Track Lite

In some cases, it may be useful for Tag & Track Pro and Tag & Track Lite features to be active at the same time.

For example:

- In Tag & Trac Pro, manual or control priority mode is selected for the PTZ mode.
- In Tag & Track Lite, an object is selected in the field of view of the camera that is designated as the overview camera for Tag & Track Pro.

In this case, both features are active: the object will be tracked by the PTZ camera and its trajectory will be used to predict the camera in front of which it will appear next.

8.2.3.6 Managing Outputs

To control a output, select **Show output** in the context menu of the viewing title.

Note

You must first activate an object before you can control its output.

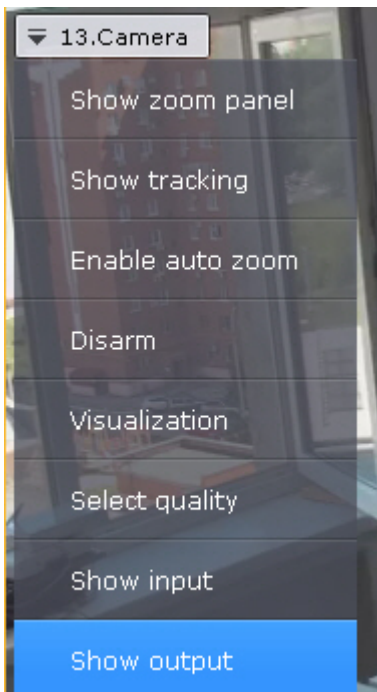

This opens **Output Switch**.

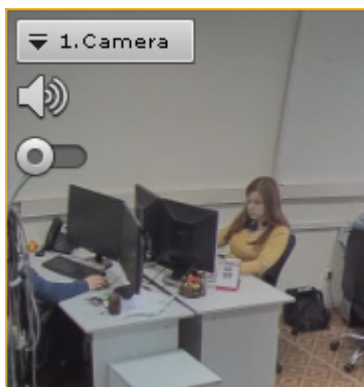



Note

To hide **Output Switch**, select **Hide output** in the context menu of the viewing tile.

You can toggle the output state by clicking the radio button.

Note

If a output is controlled by several operators simultaneously, the output will remain activated as long as at least one operator requires it.

Output Switch	Output status
	Normal
	Activated

8.2.3.7 Displaying the input status

To display the status of a video camera’s input, select **Show input** in the context menu of the viewing tile.

Note

You must first activate an object to display the status of its input.

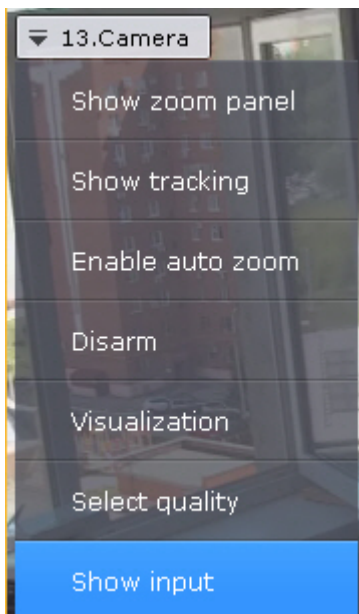



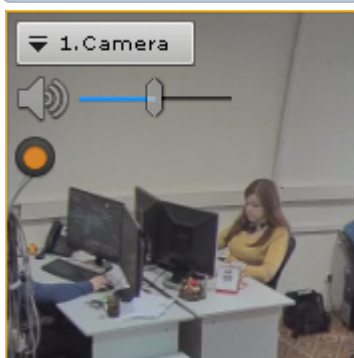

The status of the input will now appear in the viewing tile.

Note
To hide the input status, select **Hide input** in the context menu of the viewing tile.



There are four possible statuses of a input.

Input status	Description
	Video camera is armed, input is in normal status
	Video camera is armed, input is in alarm status
	Video camera is disarmed, input is in normal status
	Video camera is disarmed, input is in alarm status

8.2.3.8 Selecting video stream quality in a viewing tile (GreenStream)

If a video camera supports multistreaming, you can select the quality of the video stream that you want for display in viewing tiles.

Note

If the video camera is not configured for multiple video streams, this action is not available (see [The Video Camera Object](#)).

To select video stream quality:

1. In the context menu of the viewing tile, select **Select quality**.

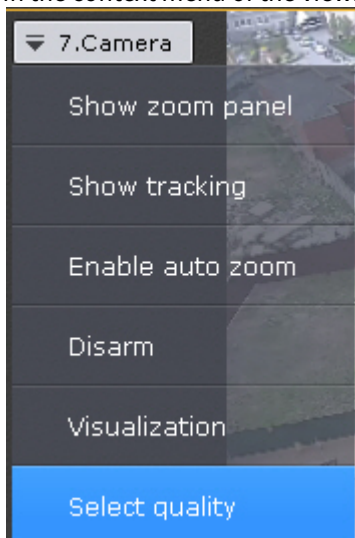

2. Select the quality of video stream that you want for display in the viewing tile.



Item	Description
Auto (GreenStream)	The default setting for video stream is low-quality. Upon selection of a Camera Window, the highest resolution stream is displayed by default. After you switch to another Camera Window, the inactive camera window returns to lower resolution / fps display
High	A high-quality video stream is used for display in the viewing tile (see The Video Camera Object).
Low (default)	A low-quality video stream is used for display in the camera window (see The Video Camera Object).. When you zoom on the camera window, it switches to a high quality video stream (see Scaling the Viewing Tile).
Adaptive	Viewing Tile shows an adaptive video stream (see Configuring an Adaptive Video Stream).

Note

Automatic video stream selection (enabled by the **Auto** option) is unavailable if automatic resolution selection has been set for any stream (see [The Video Camera Object](#)).

3. Click between between the tiles.

Selection of video stream quality in the viewing tile is now complete.

The **HQ** symbol indicates high quality stream viewing.



8.2.3.9 Autozoom

The **Autozoom** function performs automatic control of digital zoom.

If a viewing tile is inactive and autozoom is enabled, the following actions occur:

1. The smallest rectangular area that contains all tracked objects (even if object tracking is disabled) is chosen.
2. Maximum digital zoom is performed for the selected area.

If autozoom is enabled but there are no moving objects in the video frame, the contents of the viewing tile are shown at their original size.

Note

If the Fit screen function is activated for a viewing tile, the default digital zoom level is used.

Autozoom stops when a viewing tile is selected and resumes when the viewing tile is no longer active.

Autozoom can be enabled both for a single camera and for all video cameras in a layout.

To enable autozoom for a specific camera, in the viewing tile context menu, select **Enable autozoom**.

Important

Autozoom is available if:

1. the object tracker is activated for this camera (see [General information on Scene Analytics](#));
2. the Video Motion Detection tool is activated (see [Configuring VMD](#));
3. at least one of the Embedded Analytic tools is activated (see [Embedded Detection Tools](#)).

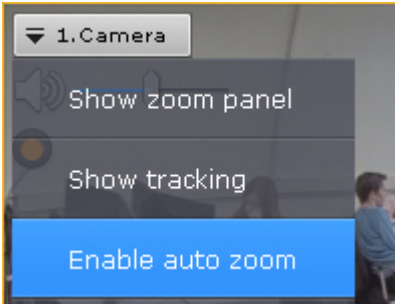
**Note**

Autozoom resizing takes into account objects from all tracking sources that are activated for a particular video camera

To disable autozoom, select the corresponding command in the viewing tile context menu.

To enable autozoom for all cameras in a layout, select **Enable autozoom for all**.

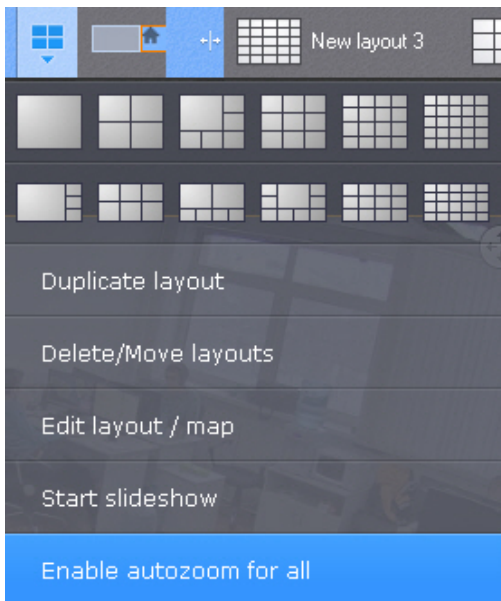

To disable autozoom for all cameras in a layout, select **Disable autozoom for all**.

Note

If autozoom is activated for one or more cameras in a layout, by default the menu displays the **Disable autozoom for all** option.

Note

When you switch to the layout editing mode, the auto zoom is disabled for all cameras.

8.2.3.10 Autoreplace Offline Cameras on Layouts

If the main camera goes offline and a sub camera is defined in the settings (see [The Video Camera Object](#)), they are automatically replaced: the sub camera shows in the tile in place of the main one.

Cameras are swapped across all layouts in the system.

When connection restores, changes are automatically undone.

8.2.3.11 Snapshot

In Live Video mode, you can "freeze" video. To do so, click the time display (scrubber) in a viewing tile.

This will cause the viewing tile to be highlighted with a blue border. A snowflake icon will appear in the time field.



In this case, the camera window will also have buttons to set the moment of time, if you want to go to Archive mode (see [Navigation via the time indicator](#)).

To return to live video, click the display again.

8.2.3.12 Viewing selected camera's detection tool triggering events

You can get quick access to selected camera's detection tool triggering events from any layout. To do it, follow the steps below:

1. Select a camera on the layout.

- 2. Click the **Events** button on the right margin of the screen. An events panel (see [Working with Events Boards](#)) opens containing detection tool triggering events for this camera only.

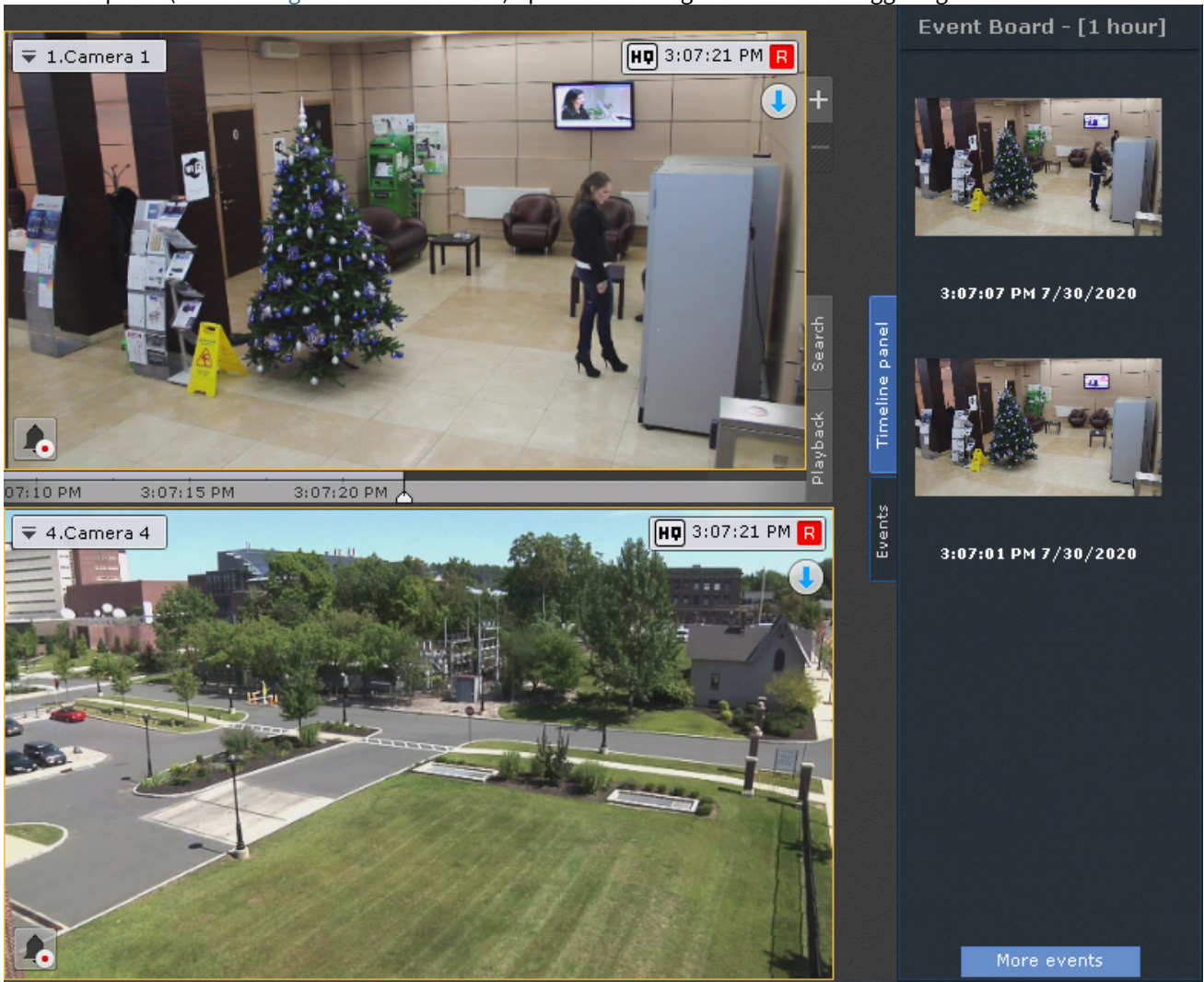

To hide the panel, click again the **Events** button.

8.2.3.13 Switching to other camera via a link in the Camera window

The Camera window may contain links to other cameras (see [Adding links to other cameras to the Camera Window](#)).



When you click a link, the corresponding camera is selected, and the Camera window expands.

If a linked camera is not present on the currently selected layout, a layout containing the required camera is selected. If there are multiple layouts containing the required camera, the layout with the least number of windows is selected.

If a linked camera is not present on any layouts, a temporary layout is selected that will be automatically deleted after you proceed to another layout.

8.2.3.14 Removing a camera from a layout

You can remove a camera from any given layout.

Attention!

These changes are not saved, and the camera will reappear when you call the layout again, or relaunch the Client.

To do it, follow the steps below:

1. Open the Camera Window context menu.

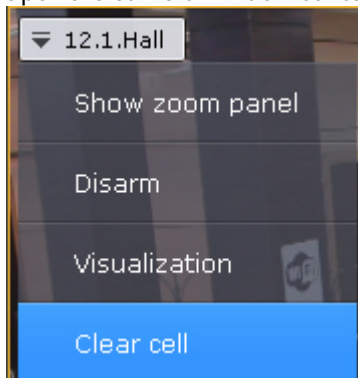

2. Select **Clear Cell**.

The corresponding layout cell becomes empty.

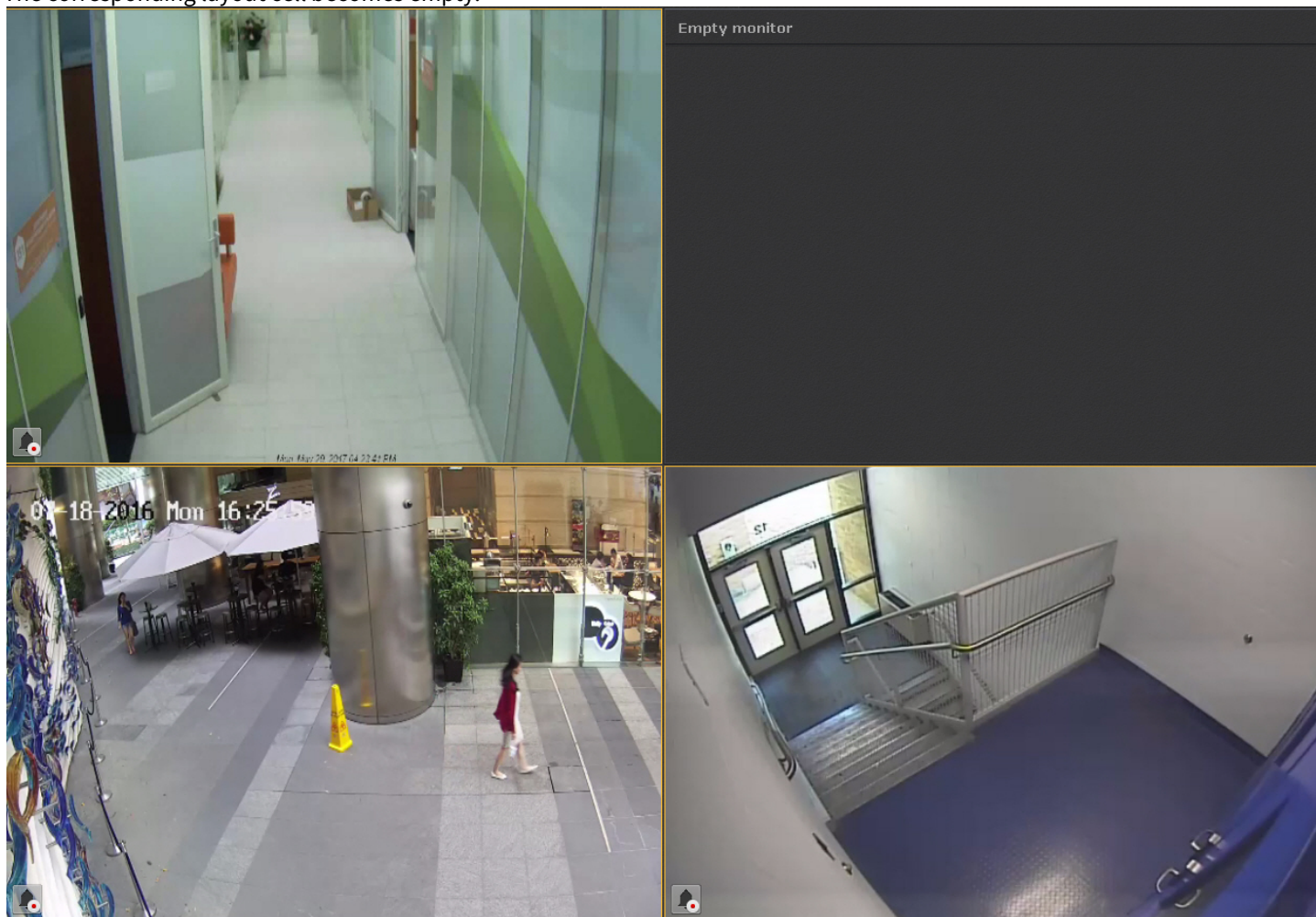

You can further drag and drop a camera from the Objects Panel (see [Objects Panel](#)) or Camera Search Panel (see [Camera Search Panel](#)).

8.2.4 Video surveillance in archive mode

8.2.4.1 Switching to Archive Mode

To switch from a different surveillance mode to the Archive mode, click the **Playback** tab in the lower-right corner of the Camera Window.

Note

If a camera is not linked to a video archive and has no on-board storage, this tab will be not available.



You can also switch from Live Video mode to Archive mode if you select a position on the advanced archive navigation panel (see [Advanced archive navigation panel](#)).

Note

In Live Video mode, if the viewing tile is not active, the tabs for switching to other modes and the advanced archive navigation panel are not displayed. To activate, click the viewing tile

To switch all cameras within a layout to Archive mode, click the **Playback** button on the upper panel.

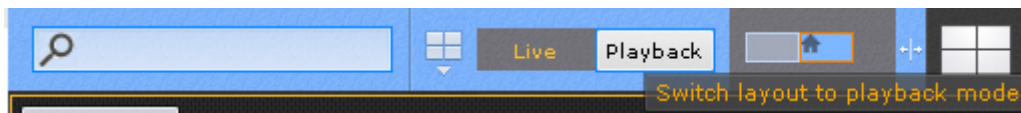

To return to live viewing, click **Live**.

Furthermore, if all cameras within a layout are in Live Video mode, you have to open the Archive navigation panel to switch the cameras to Archive mode (see [Show and Hide the Archive Navigation Panel](#)).

Note

If archive mode is selected as the default video mode for a camera in a layout, when you switch to that layout, the camera is immediately in archive mode (see [Selecting the default video mode for a camera](#)).

On first access to Archive mode, the most recently recorded video will be selected on the timeline (see [The Timeline](#)). On further accesses to a particular camera archive, the timeline indicator will show the position of the most recent video in the Archive.

Attention!

If you prefer to open the most recently recorded video when accessing the Archive (Video Footage), create a `ResetArchivePosition` parameter in the following registry key on the Client:
`HKEY_LOCAL_MACHINE\SOFTWARE\AxxonSoft.`

Click  to create a temporary layout for Archive (video footage) viewing.

The temporary layout is not preserved after you switch to any other layout.

8.2.4.2 Video Surveillance Functions Available in Archive Mode

In archive mode the following video surveillance functions are accessible:

1. Autozoom.

Note

Refer to section [Real-time video surveillance](#) for a description of switching to the results of a saved search query and the **Autozoom** function.

2. Selecting an archive for viewing of recordings.
3. Synchronized playback of archives.
4. Compressed playback of archives.
5. Viewing recorded video with operator comments.
6. Viewing external archives.
7. Navigating through the archive.
8. Displaying why situation analysis detection units have been triggered.
9. Viewing the results of a saved search query.
10. Manual archive replication.
11. [Tag & Track Lite](#).
12. [Functions Available in All Video Surveillance Modes](#).

8.2.4.3 Selecting an Archive

You can select video footage to view only if the camera is recording to several archives.

If you do not select an archive, the default archive is played back (see [Binding a camera to an archive](#)).

To select another archive for playback:

1. Click the archive name or the  button on the advanced archive navigation panel.

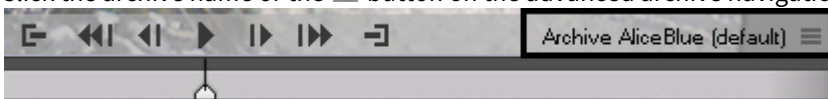

2. Select the required archive from the list.

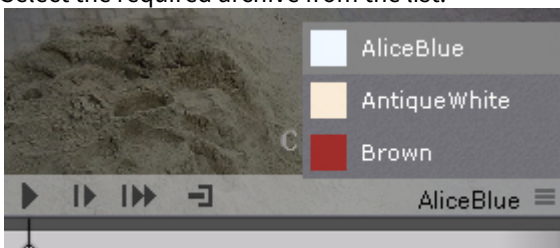

Note

You can select all available Mirror Archives (if any, see [Configuring data replication](#)) and on-board storage (if enabled, see [The Embedded Storage object](#))

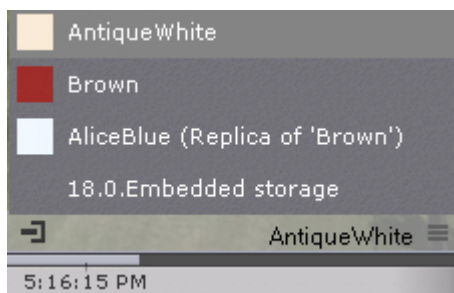

You can now view video footage from the selected archive in the viewing tile.

Attention!

The next time you enter the Archive mode, the selected (not default!) archive will be displayed.

Note

If there is no recording in the selected archive, a message to that effect will appear in the viewing tile.

8.2.4.4 Viewing a combined Archive

In some cases, you might need to record videos from a single camera into multiple Archives.

For example, videos triggered by Detection Tool #1 go into into Archive #1, and videos triggered by Detection Tool #2 are recorded into Archive #2.

For more user convenience, *AxxonNext* offers an option to visually combine records from different Archives.

To view a combined Archive, you need:

1. Go to the Archive selection menu (see [Selecting an Archive](#)).
2. Check boxes for the Archives to be combined.

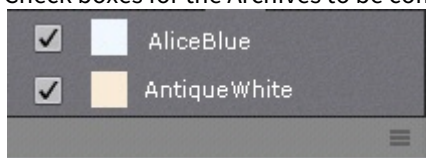

Records from all checked Archives will appear on the timeline. You can apply any system function to a combined Archive.

Note

Clicking on a particular Archive brings you to viewing videos from this Archive only.

Note

If you select multiple archives for a particular camera, and then switch all the layout to Archive mode, all cameras will be set to multi-archive display.

When combining multiple streams from the same camera into one Archive, the highest quality stream is prioritized.

For example, if

- a lower quality video stream is permanently recorded into Archive #1,
- and a high quality video stream is recorded into Archive #2 by VMD,

then the combined Archive will consist of high quality motion-triggered records and low quality "other" videos.

8.2.4.5 Synchronized playback of archives

Synchronized playback of archives lets you play back archives from several different video cameras simultaneously.

To enable synchronized playback, switch a few video cameras into archive mode. The timeline will then display time axes for the corresponding archives.

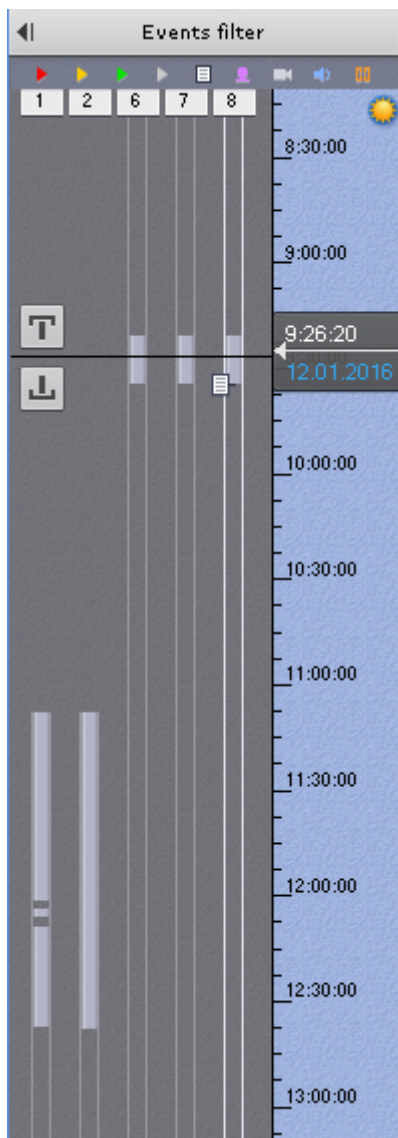

Synchronized archive playback is controlled through the playback panel in the same way as playback for a single archive.

8.2.4.6 Compressed playback of archives (TimeCompressor)

During compressed playback (TimeCompressor), the viewing tile simultaneously displays tracked objects from different moments in time within the selected portion of the archive. This lets you quickly look through the archive to find important events and investigate them in more detail.

For condensed playback of archived video from a camera, the following conditions must be true:

1. Camera is bound to an archive (see [Binding a camera to an archive](#)).
2. The camera must have at least one active source of metadata (Object Tracker, Video Motion Detection, Embedded Analytics).

Attention!

For the Object Tracker, you have to select the video stream currently selected for Video Footage recording (see [Setting General Parameters](#)).

8.2.4.6.1 Switching to TimeCompressor mode

To use TimeCompressor, complete the following steps:

1. You can set the time span for viewing video in TimeCompressor on the timeline in one of the following ways:
 - a. Set the pointer to the start position. In that case you view the whole archive to the end of it (see the section titled [Navigating Using the Timeline](#)).
 - b. Select the time span with the right-click.

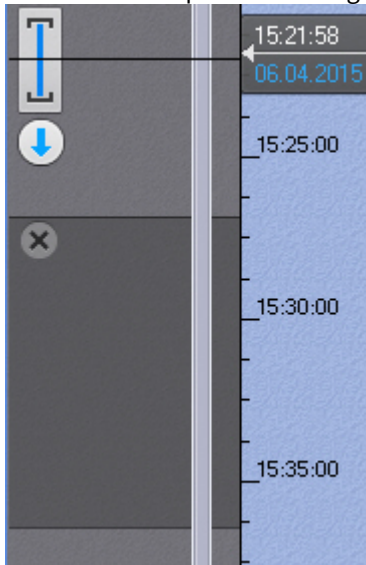
**Note**

The TimeCompressor mode allows you to view the results of a specific archive search (see [Viewing Search Results In TimeCompressor](#)).

2. Click the  button on the Advanced Archive Navigation Panel

The archive will now start playing in compressed mode.

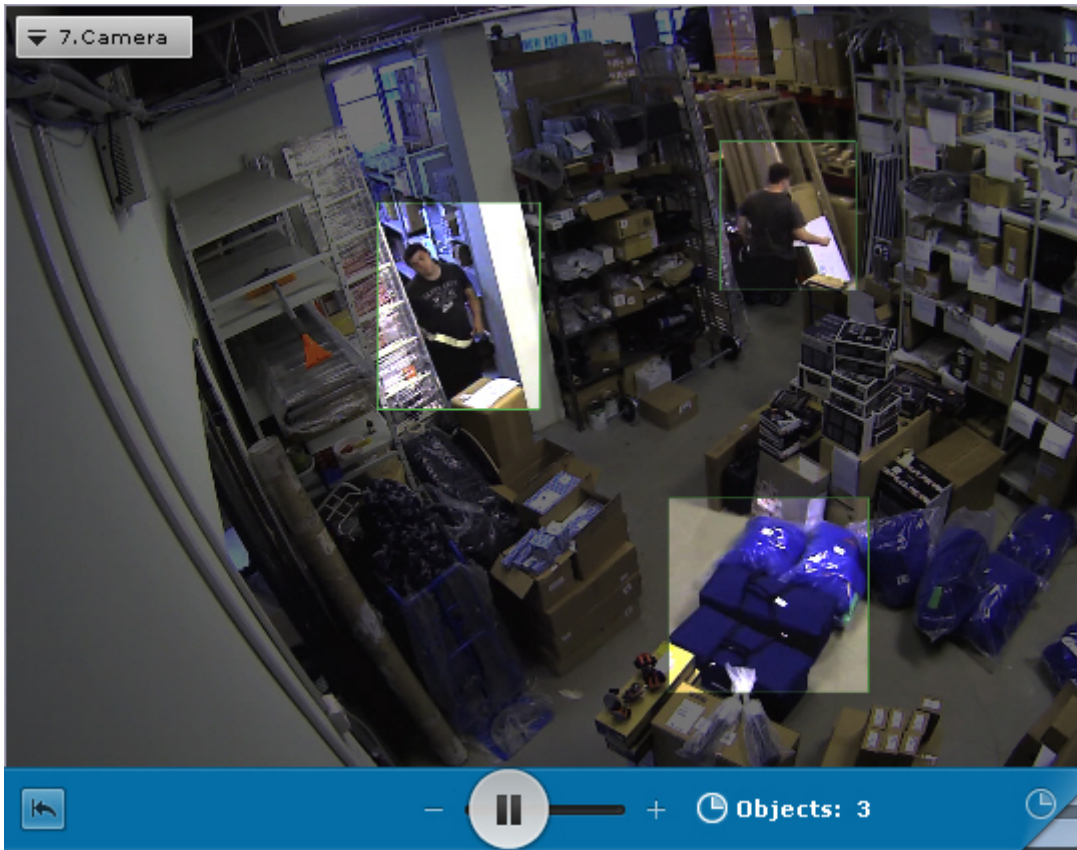
**Note**

Only one video camera can run TimeCompressor at one time. If synchronized playback is started and a video camera is switched to TimeCompressor mode, playback of all other video cameras will be automatically paused.

Note

To switch back to the standard archive browsing mode, click the displayed area of the Advanced Archive Navigation

Panel .

8.2.4.6.2 Playback control

Playback control in TimeCompressor mode is managed using the advanced navigation panel and the playback panel.

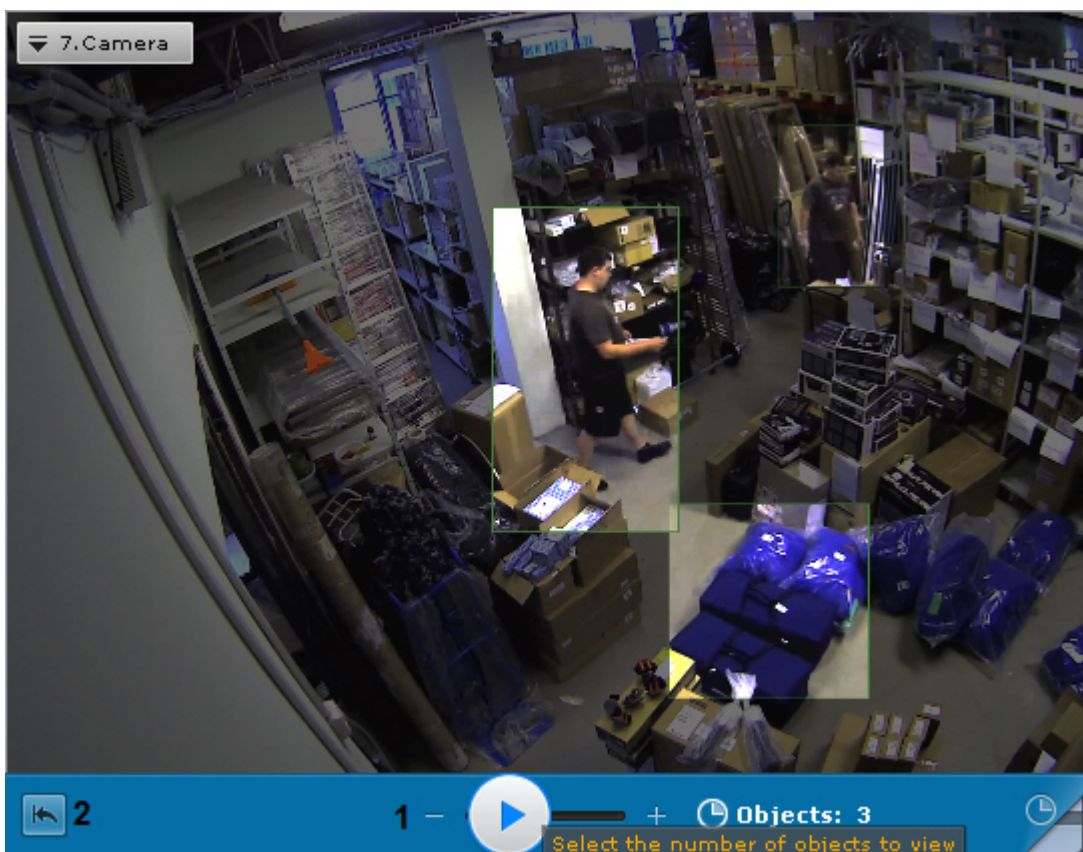

To set the desired number of tracked objects to be simultaneously displayed, set the slider in the appropriate position (**1**). The extreme left position of the slider corresponds to two objects, the extreme right - sixteen.

**Note**

Once you have configured this setting, playback begins at the beginning of the selected interval.

Note

However, according to the logic of the algorithm, the number of displayed objects may be greater.

To stop or start playback, use the  and  buttons on the playback panel or the identical buttons on the advanced navigation panel.

To start archive playback in TimeCompressor mode starting at the beginning of the selected interval, click the  button (2).

8.2.4.6.3 Switching back to the original recording of an object

To leave TimeCompressor mode to go back to the original recording of an object, left-click the object.

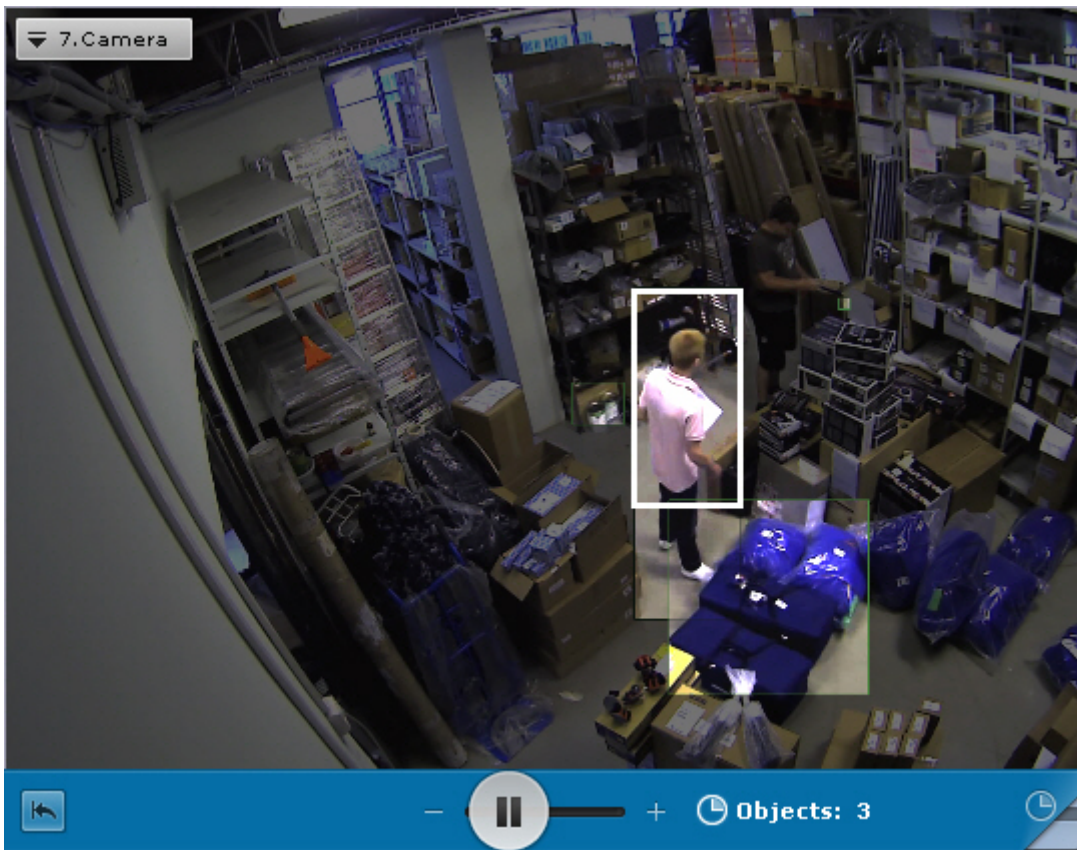

The system will now automatically switch back to the original recording of the object in standard archive playback mode. Playback of the recording will be paused, and the beginning of the recording will correspond to the moment at which the object was selected.

The period during which the objects remains in the camera's field of view is displayed in the viewing tile.

Note

Once you have switched back to the original recording of the object, you can return to TimeCompressor mode to the place where the switch was made. To do this, click the  tab. In this case, playback in TimeCompressor mode will be paused.

8.2.4.7 Viewing recorded video with operator comments

Operator comments are displayed when recorded video is played back in a viewing tile.

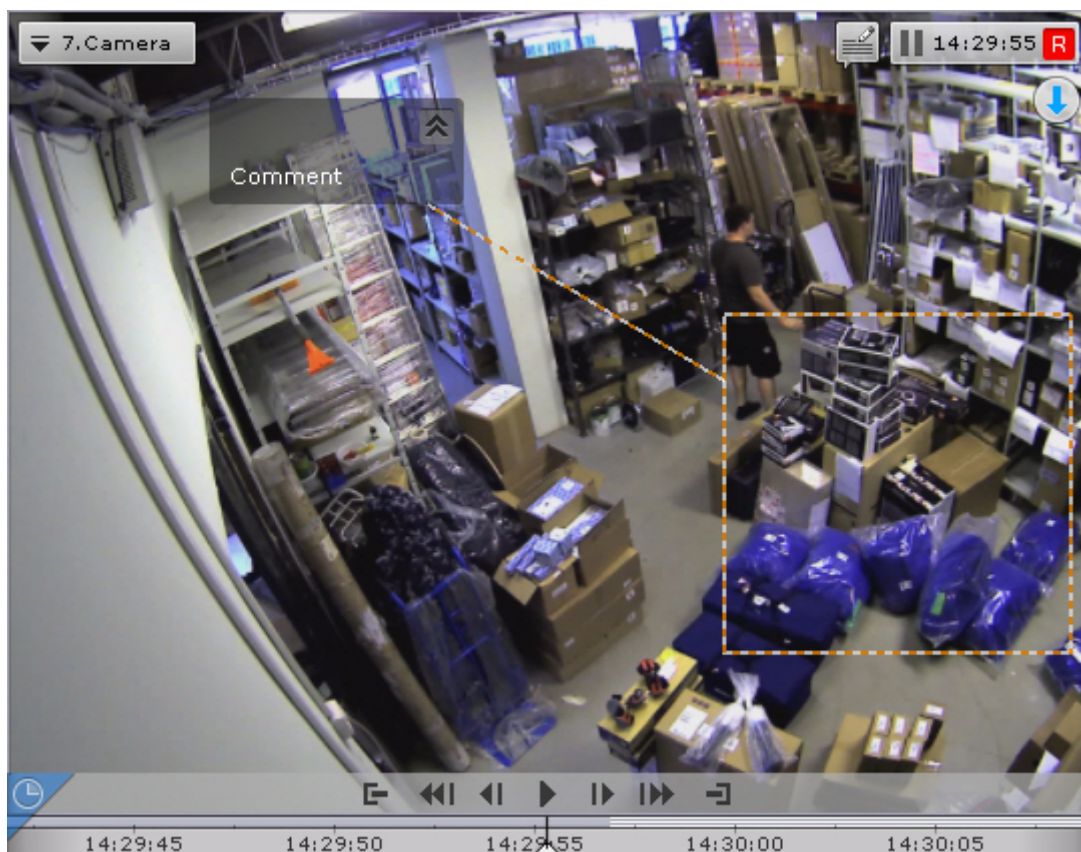

Comment text begins display five seconds before the frame for which the comment was added (before the first frame, if the comment was set for an interval), with gradual outlining of the area (or point) that was specified when adding the comment. When the commented frame is shown or during the commented interval, the area (or point) is also highlighted,

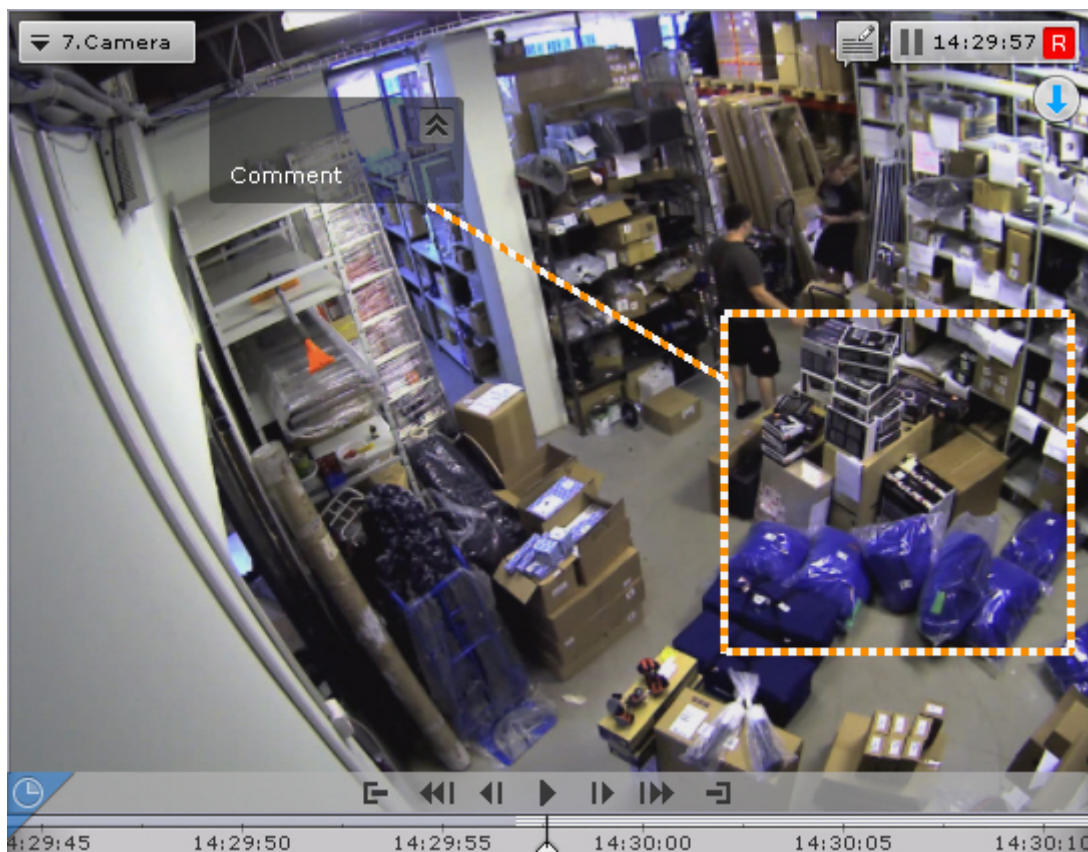

Five seconds after the commented frame (after the end of the interval, if the comment was for an interval), the comment is hidden.

To minimize comments and the displayed area, if any was specified, click the  button.



To return to the full comment, click the  button.

8.2.4.8 Viewing External Archives

External Archive is time-referenced video footage (see [Importing video to Axxon Next](#)).





If you go to Archive mode, the timeline shows available video recordings. If there is no time overlapping for video recordings, the space between them is blank.

If video recordings overlap, they are displayed as one track that spans from the beginning of the first video clip to the end of the second.

If you want to watch this track, both video clips are played sequentially and in full.

8.2.4.9 Delete a part of an archive

You can delete an arbitrary part of an archive. To do this:

1. Set the time interval for the footage to be deleted from the archive:
 - a. on the main timeline, set the indicator to the beginning of the interval, click the  button, then set the indicator to the end of the interval and click  again; as an alternative, you can right-drag the mouse over the required interval. To delete the interval, click ;
 - b. on the additional navigation panel, you can set the time interval the same way using the   buttons. You cannot set the interval with the mouse on the additional panel.

2. Click  in the Camera window.

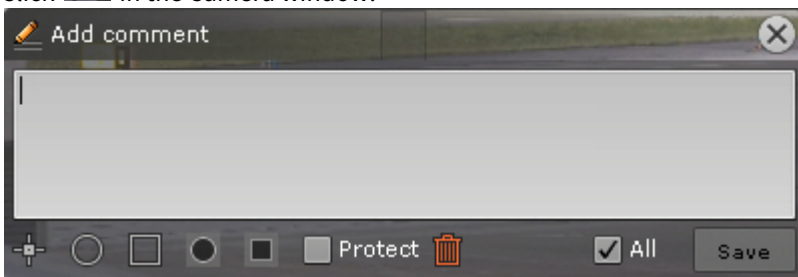

3. To delete footage within the specified time interval for all cameras within the archive, check the **All** box .

4. Click .

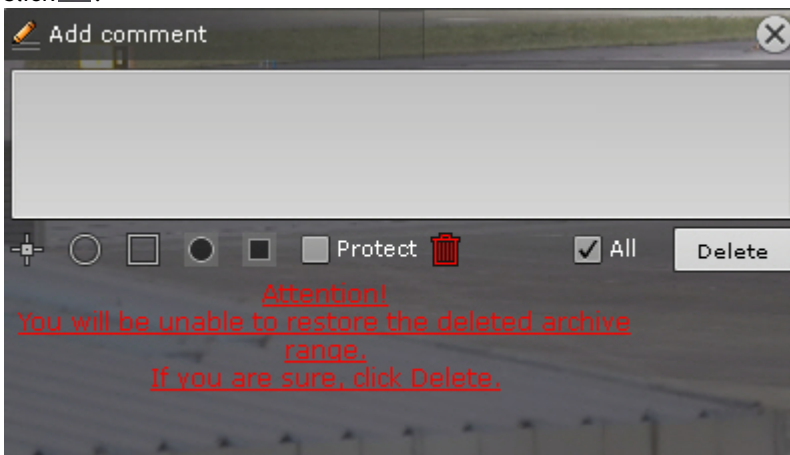

5. Click the **Delete** button to confirm the deletion.

Attention!

You cannot recover deleted footage.

Attention!

If several archives were selected for viewing (see [Viewing a combined Archive](#)), the footage will be deleted from all of them.

After the deletion is complete, the remaining footage may contain some artifacts near the cut points.

8.2.4.10 Navigating in the Archive

You can navigate in the archive using the following interface elements:

1. Timeline
2. Advanced navigation panel
3. Events list
4. Playback panel
5. Time indicator

You can also navigate through the archive by easily flipping through recordings.

8.2.4.10.1 Navigating Using the Timeline

Note

Use of the timeline is described in detail in the section [The Timeline](#).

You can select recordings in the archive for playback in a viewing tile by using the timeline, in one of two ways:

1. Left-click the indicator (1) and drag it to the corresponding position on the timeline. Alternatively, you can left-click the left portion of the timeline.

Note

The position on the timeline is a graphical representation of a specific moment in time.

The frame corresponding to the selected position (moment in time) will then be displayed in the viewing tile (2).

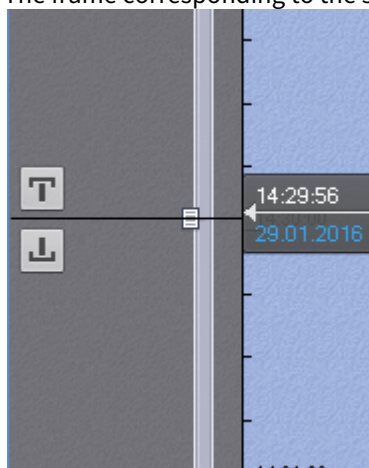

Attention!

If the system clock is shifted back one hour (for example, in winter saving), the videos from the lost hour will disappear from the timeline but remain accessible.

For example, at 3 PM the clock is shifted back one hour. If you place the timeline marker anywhere after 02:00:00, videos shot after the shift will be played back.

If you set the marker to 01:59:59 or earlier, videos shot from 01:59:59 to 02:59:59 (time stamped before the shift) will be played back.

2. Click the indicator. The calendar opens. Select the date to which you want to jump in the archive and specify the time in HH:MM:SS format, by using the arrows or keyboard number keys.

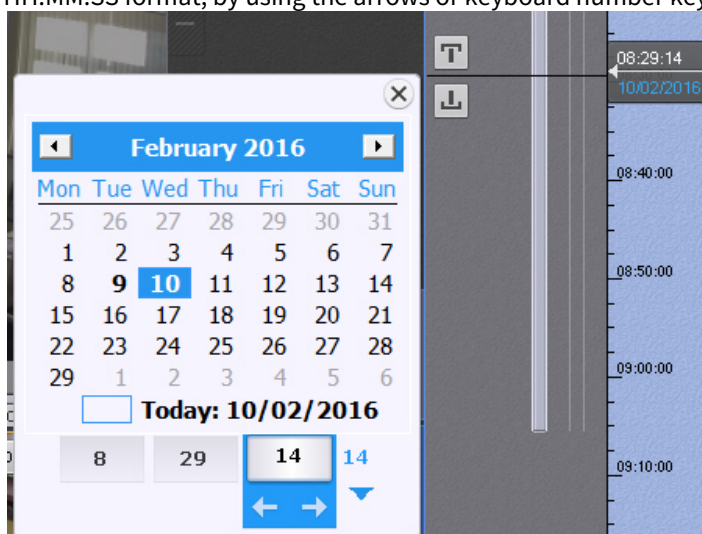

Note

The Tab key can be used to navigate across various elements of the Calendar.

You are then taken to the specified point in the archive.

If one video camera is in archive mode and you move the indicator to a point for which there is no video, the indicator will automatically go to the video for the closest point in time. If two or more video cameras are in archive mode, you will not be taken to the video for the closest point in time; the message **No archive** will be shown on screen.

To play back the selected recording, use the playback panel (see the section titled [Navigating Using the Playback Panel](#)).

8.2.4.10.2 Navigation using the advanced panel

You can use the advanced navigation panel to select recordings in the archive for playback in the viewing tile. To do this, complete one of the following two actions:

1. Left-click the timeline (1) and hold down the button while dragging the scale to the desired position.
2. Left-click the desired moment in time on the timeline.
3. Left-click and hold the desired moment in time on the timeline.

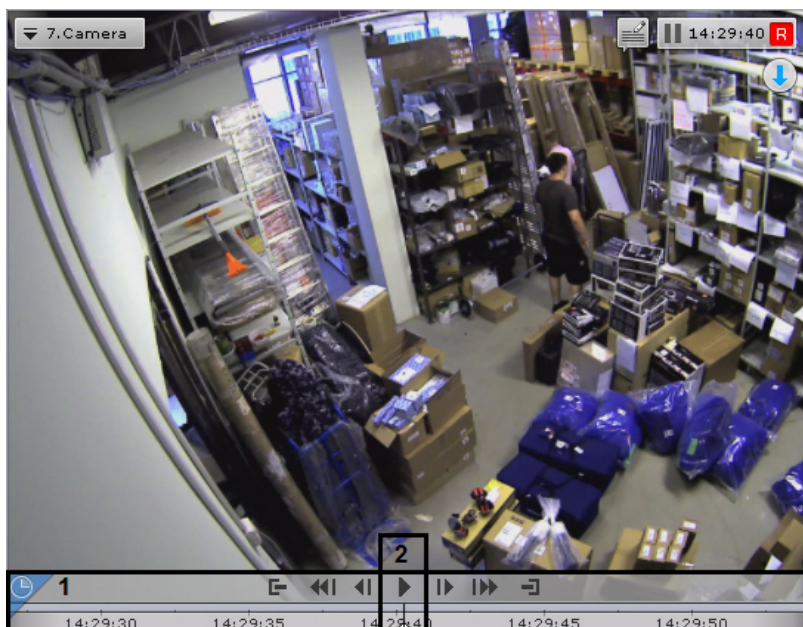



When you left-click and hold left the mouse button and the timeline is moved, you can view the corresponding recording in fast forward. The further left you click, the faster is the playback speed.

Note









The current moment in time is determined by the cursor located in the center of the timeline (2). The position of the cursor relative to the timeline never changes.

Once the selected moment is reached, playback stops. The speed of playback depends on the speed of the timeline’s movement.



To start archive playback click  in the middle of the timeline. To pause playback, click the  button or left-click the timeline.

To control playback, use the playback panel (see the section titled [Navigating Using the Playback Panel](#)) or the advanced navigation panel.

Playback		Pause	
Item	Description	Item	Description
	Decreases playback speed by one level		Go to the preceding frame
	Increases playback speed by one level		Go to the next frame
	Go to the previous recording		Go to the previous recording
	Go to the next recording		Go to the next recording

Attention!

Click and hold the  button to jump to the end of the archive.

8.2.4.10.3 Navigating Using the Events list

The Events List and the timeline are dynamically linked: when you select an event in the list, the timeline indicator automatically jumps to the selected position.

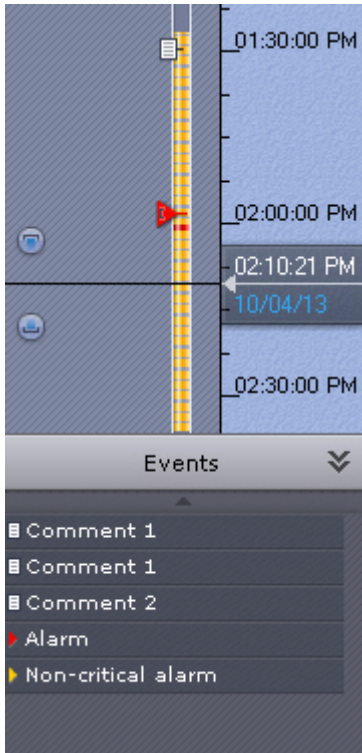

For details, see the section titled [Events List](#).

8.2.4.10.4 Navigating Using the Playback Panel

To navigate in the archive using the playback panel, you must first select a recording for playback.

Once a recording is selected, the following operations are accessible:

1. Play recording: 
2. Pause/Stop playback: 
3. Go to the preceding frame 
4. Go to the next frame 
5. Go to the previous recording 
6. Go to the next recording 

You can fast-forward / fast-rewind and change playback direction (forward / back).

Fast-rewind playback.

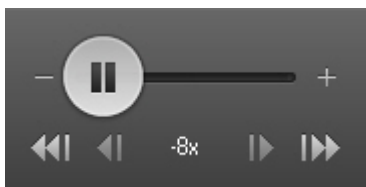

Slow playback.

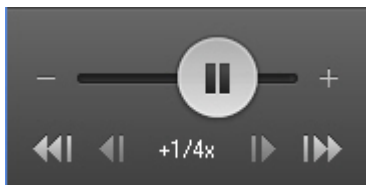

For reverse playback of a recording, move the slider to the left of the position corresponding to zero playback speed (the center of the slider); for forward playback, move it to the right. The current playback speed is displayed under the slider. During forward playback of a recording, a + sign appears before the speed; during reverse playback, a - sign appears. The value **0X** corresponds to zero speed, i.e., no playback; the value **1X** corresponds to the frame rate of recording.

To speed up playback by one step, click +. To slow down by one step, click -. To temporarily change the playback speed, move the slider in the desired direction.

To slow playback N-fold, do as follows:

1. Accelerate playback N-fold:
2. Click the value of the current playback speed below the slider.

This slows the playback N-fold. To return to the fast playback, click the current speed again.

Note

Forward playback speed can be increased up to 32x, reverse playback speed — up to 8x.

8.2.4.10.5 Navigation via the time indicator

The time indicator in a viewing tile can be used to set the time of the current day on the timeline to which you want to navigate in the archive.

To do so, left-click the indicator and specify the time in HH:MM:SS format, by using the arrows or keyboard number keys.

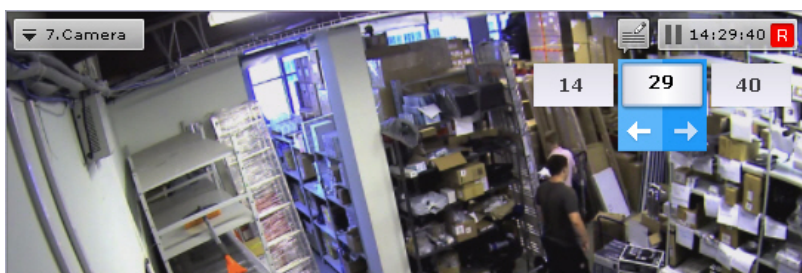

You are then taken to the specified point in the archive.

If one video camera is in archive mode and you try to navigate to a point for which there is no video, you will be automatically taken to the video for the closest point in time. If two or more video cameras are in archive mode, you will not be taken to the video for the closest point in time; the message **No archive** will be shown on screen.

8.2.4.10.6 Keyboard navigation

You can use keyboard shortcuts to navigate through an archive and control video playback.

Key or key combination	Resultant action during pause	Resultant action during play
------------------------	-------------------------------	------------------------------

Spacebar	Begins playback	Pauses playback
Ctrl+Spacebar	Uses the current position to set the export interval	Uses the current position to set the export interval
Up-Arrow	Increases playback speed by one level	Increases playback speed by one level
Down-Arrow	Decreases playback speed by one level	Decreases playback speed by one level
Left-Arrow	Moves back to the preceding key frame	-
Right-Arrow	Moves forward to the next key frame	-
Page up	Switches to the preceding recording	Switches to the preceding recording
Page down	Switches to the next recording	Switches to the next recording

8.2.4.11 Displaying the causes of triggered situation analysis detection units

When positioning the archive in the range [-1 sec.; +1 sec.] from when the situation analysis detection unit was triggered, the objects that triggered the detection unit will be marked on the video frame.



8.2.4.12 Viewing the results of a saved search query

If the system has saved Forensic Search queries for a video camera, tabs for these queries are displayed in the lower-right corner of the corresponding viewing tile.

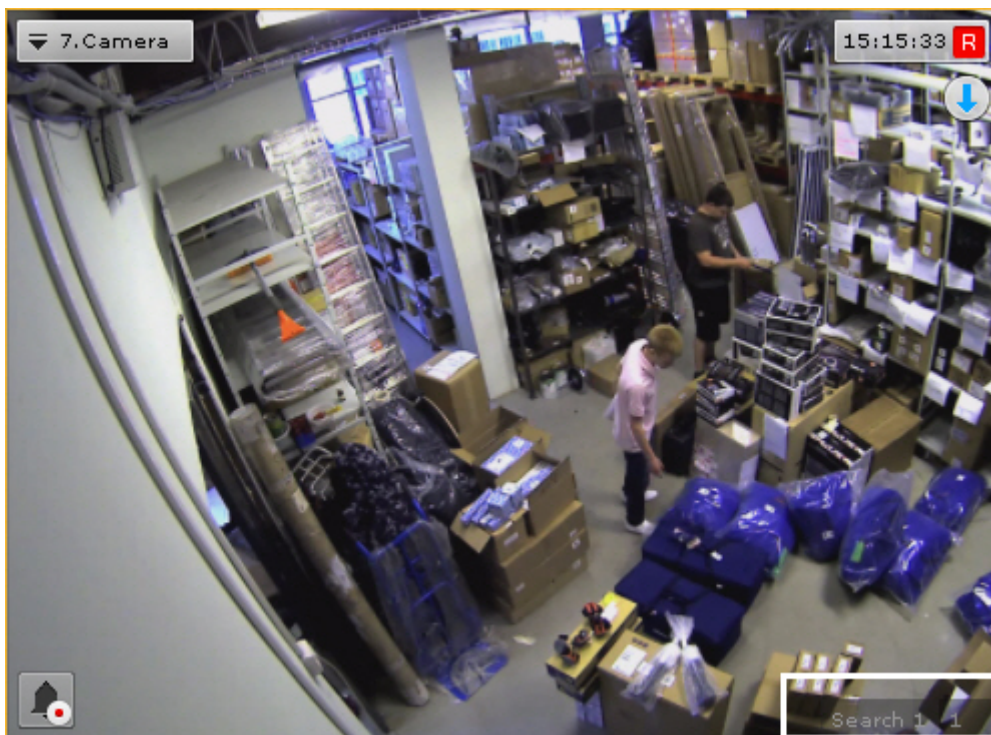

If not all tabs fit in the viewing tile, a full list of saved Forensic Search queries is available by clicking the << button.

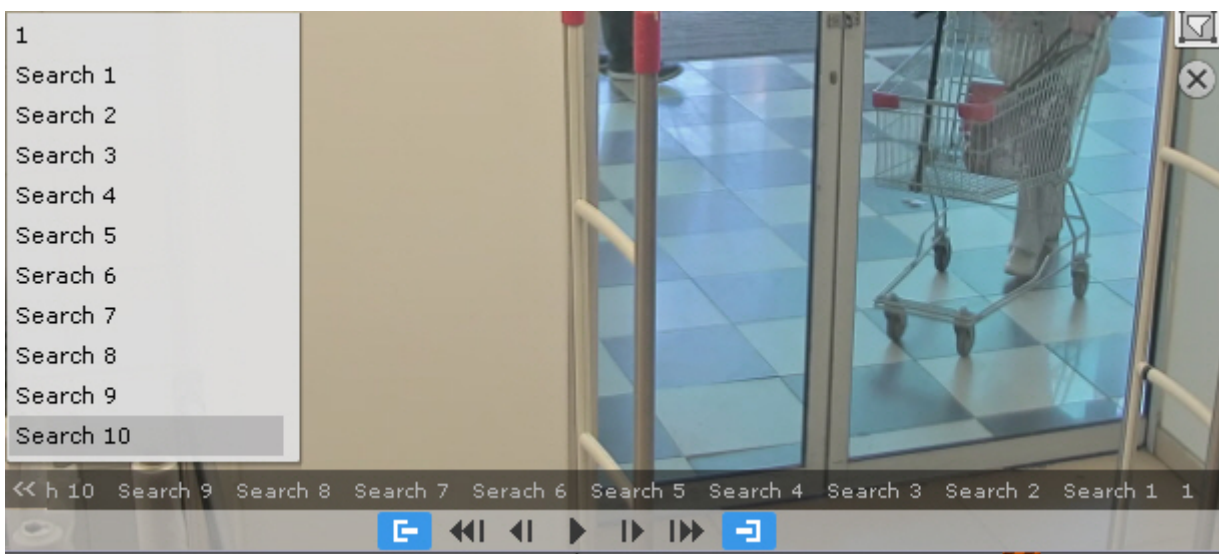

Clicking a tab switches to Archive mode, displaying the results of the relevant search on the timeline (the process is similar to viewing search results in Archive Analysis mode).

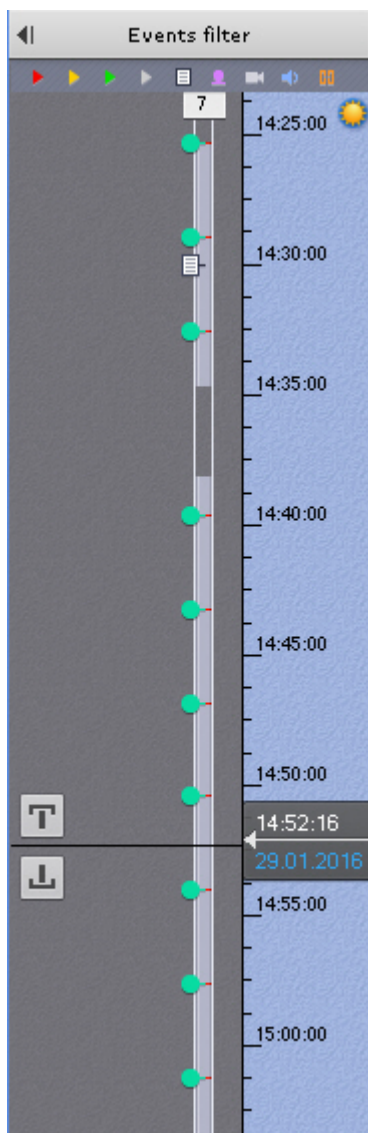

The standard Archive mode controls are used for navigating between search results (see [Navigating in the Archive](#)).

Note

To search in standard archive mode without displaying search results, click the corresponding tab in the viewing tile.

The parameters for the search are displayed when switching from search results to Archive Analysis mode.

8.2.4.13 Manual Archive Replication

You can protect selected video recordings from being overwritten. To do this:

1. Create a new archive (see [Creating Archive](#)) and configure on-demand replication for it (see [Configuring data replication](#)).
2. Switch to Archive Mode (see [Switching to Archive Mode](#)).

- Set the time interval on the timeline (see [Standard video export](#)). Recordings from this range will be copied to the new file.

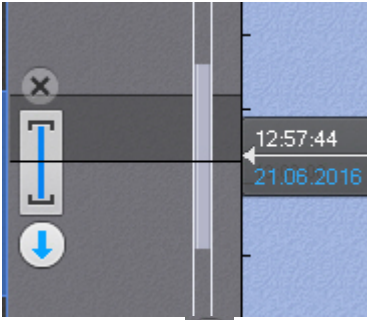

- Click the button .
- In the **Export folder** (1), select the archive where selected recordings will be copied.

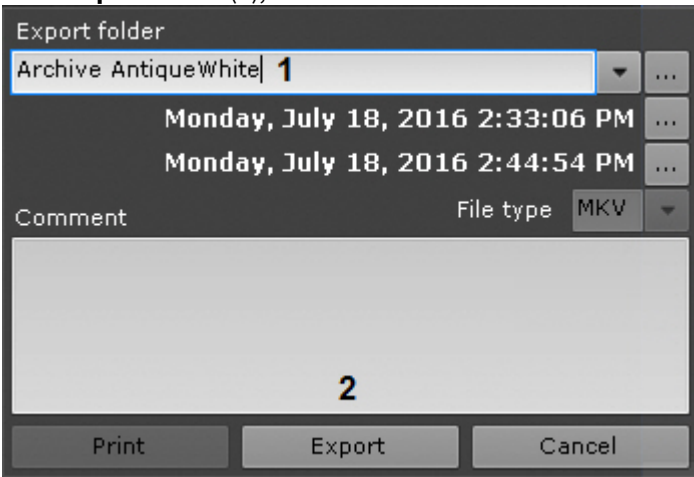

Attention!

You can replicate recorded video only to the "right" end (later point in time) of the archive. It is not possible to overwrite existing data in the archive.

If the selected replication range starts and ends earlier than the starting time of the mirror archive (e.g. you want to copy a hour of video footage from 9 a.m. to 10 a.m., but the mirror archive starts at 11.a.m.), replication will not be possible (the **Export** button is not available).

- Click the **Export** button (2).

Selected recordings have now been copied to the specified file.

8.2.4.14 Tag & Track Lite in Archive mode

[Configuring Tag & Track Lite](#)
[Tag & Track Lite](#)

Attention!

For Tag & Track Lite to work, you must activate object tracking in the viewing tile (see the [Tracking objects](#) section).

Tag & Track Lite in the archive mode works as follows:

1. Left click an object's track to select the object of interest.

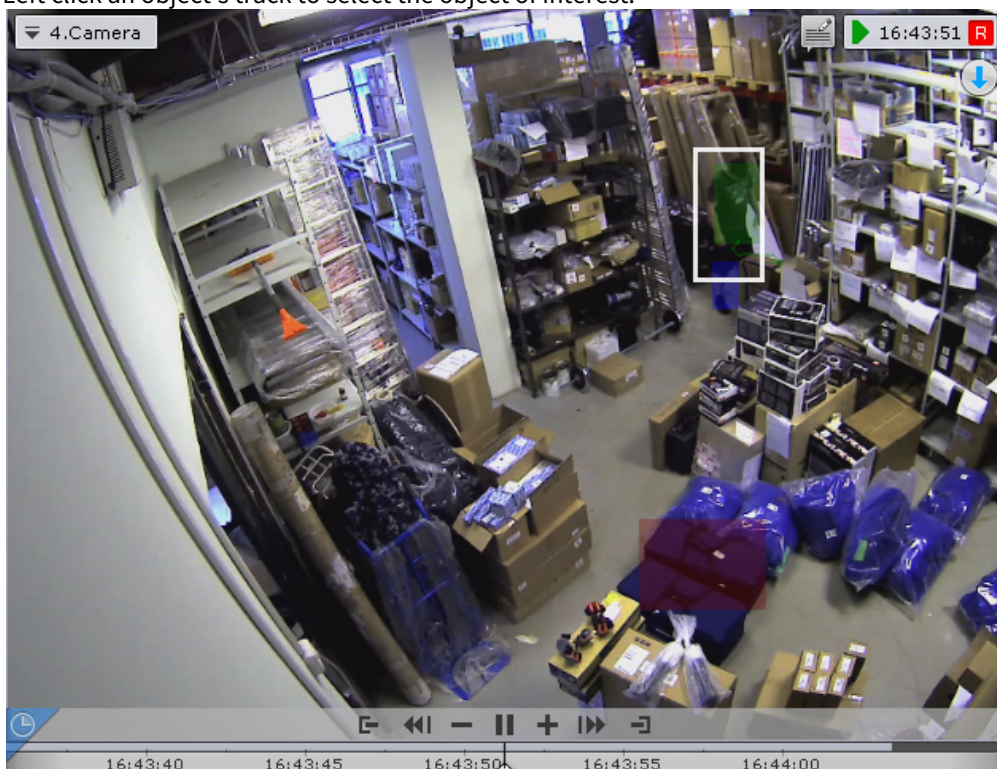

2. The most probable camera where the object **may have been** captured next is suggested.
3. After selecting an object, you are switched to the suggested camera. Camera footage will be played back automatically from the moment when the target object was supposed to appear in the FoV.

Attention!

Tag & Track Lite merely predicts, and therefore cannot guarantee, that the object will appear in front of a given camera.

8.2.5 Video surveillance in Alarm Management mode

8.2.5.1 Video surveillance functions available in Alarm Management mode

The following video surveillance functions are available in Alarm Management mode:

1. Forwarding and reversing playback of an alarm at various speeds.
2. Evaluating alarms (assigning a status).
3. [Functions Available in All Video Surveillance Modes.](#)

8.2.5.2 Switch to Alarm Management mode

When an alarm is initiated, the system switches to alarm mode automatically at the moment the event is accepted for processing. Operator can escape the Alarm management mode. To return a viewing tile from a different surveillance mode to

Alarm Management mode, in the lower-left corner of the tile, click the  button.



The viewing tile will then appear in **Alarm Management** mode.

If there are multiple alarms for a camera, Alarm Management mode will open to the most recent alarm.

8.2.5.3 Initiating an Alarm

A system alarm can be initiated in one of two ways:

1. Manually (by an operator)
2. Automatically (when a detection tool is triggered)

Note

You can initiate an alarm only if the specific video camera is linked to the archive.

8.2.5.3.1 Manual Initiation

To initiate an alarm manually, you must perform the following steps:

1. In the lower-left corner of the viewing tile, click the  button.



2. The operation will trigger an alarm that appears on Alarms Panel (see [Alarms Panel](#)). To classify an alarm, click the  button again.

Note

When in Alarm Management mode, the user that initiated the alarm will be indicated at the bottom of the viewing tile.

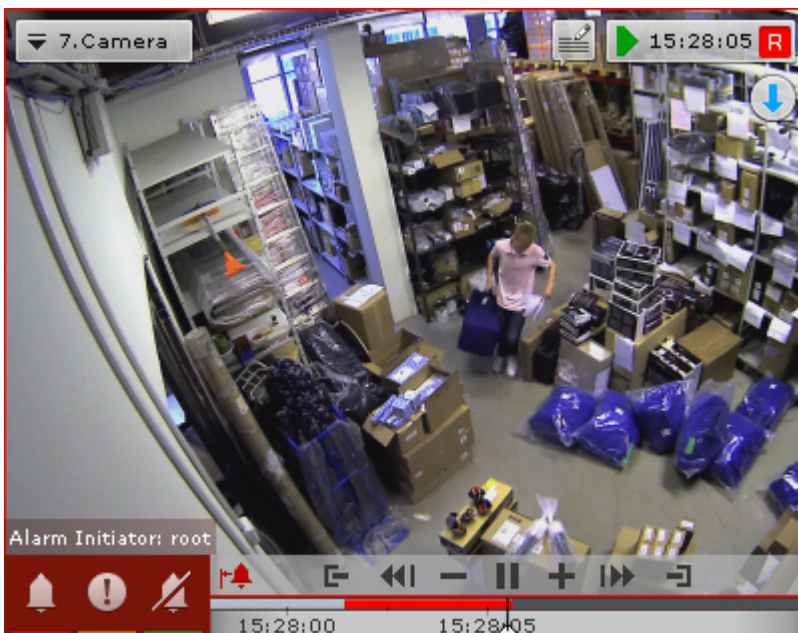

Manual initiation of an alarm is now complete.

8.2.5.3.2 Automatic Initiation

Automatic rules or macros can be configured to initiate an alarm (see the section titled [Trigger an alarm](#)).

If an alarm is initiated automatically, the **Alarms Panel** tab is color-coded .

To evaluate the situation, click the Alarms Panel tab, select the event and classify it in Alarms Management (see the section titled [Selecting Events for Alarm Management](#)).

8.2.5.4 Working with Alarms Panel

8.2.5.4.1 Viewing Alarms in Event Preview

Each alert / alarm event is displayed on Alarms Panel as follows: Each Event Preview tile shows a thumbnail with the first frame of video footage for the relevant event; the playback button; time stamp of the event and camera ID.



When you hover over the Event Preview tile, all information about the alarm pops up.

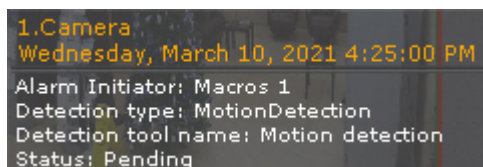

If you click the  button, the event footage / alarm recording will then be played back in Event Preview in a repeating cycle.

To stop playback, click the  button.

On the Alarms Panel, click on the alarm event video window to play back the event video in the camera window.

If the  button is activated on the Alarms Panel, the alarm video will appear in a temporary layout containing just the current camera.

If the button is inactive, the video playback will start in the regular layout.

8.2.5.4.2 Outlining Objects that Triggered Detection

In the Event Preview tile, you can outline objects that triggered detection / an alarm. To do so, click the  button.

The object is outlined only if the alarm was initiated by detection tools.

To undo object outlining, click the  button again.

8.2.5.4.3 Selecting Events for Alarm Management

When you click the Event Preview tile, a layout opens that has the relevant camera's view. The layout is selected automatically with the following algorithm:

1. The system searches for layouts that contain the alarmed camera. The user must have permissions to view it.
2. The system chooses the layout with the minimum number of cells to display the selected video camera.

3. If the required layout does not yet exist, the system creates a new layout with a single video camera.
4. The system switches to the selected layout.
5. The video camera becomes active in the selected layout. The viewing tile is expanded by one level. It switches to the Alarm Management mode. (if you have selected an active alarm) or to the Archive mode. (if you have selected a processed / classified alarm or missed / unclassified).

8.2.5.5 Working with the Alarm Management window

8.2.5.5.1 Alarm Handling Tile Interface Elements

The alarm handling tile is a viewing tile which, besides the standard interface elements (context menu, time indicator, etc.), also contains elements for alarm playback and evaluation:

1. Playback panel
2. Timeline
3. A button for quick positioning of the timeline indicator in the position corresponding to the beginning of the alarm.

8.2.5.5.2 Alarm Playback

As soon as an alarm is accepted for evaluation, the alarm recording is played back automatically one time, at 1X speed. Playback is launched either from the moment of the beginning of the alarm, or from the moment corresponding to the position of the alarm flag (only when the alarm is initiated automatically; see the section [Trigger an alarm](#)).

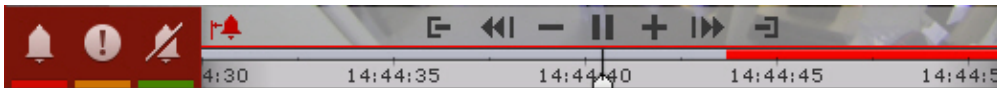

If the alarm was initiated automatically, the visual element set for the detection tool which initiated the alarm will be displayed in the viewing tile: or a detection area or virtual tripwire, which triggers the detection tool when it is crossed. The object which caused the trigger will be outlined with a red frame.

Display of an Area visual element:

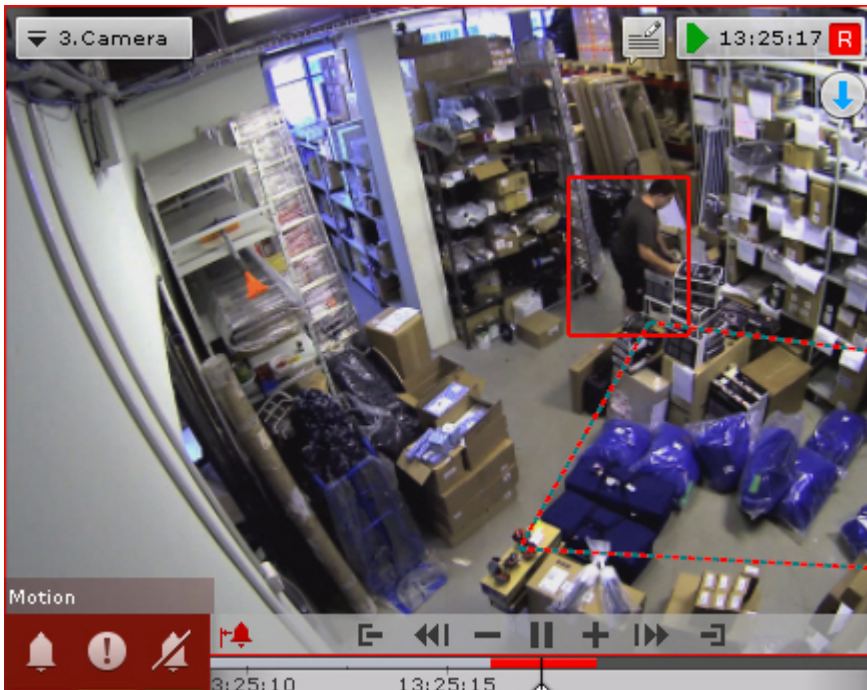

Display of a Line visual element:

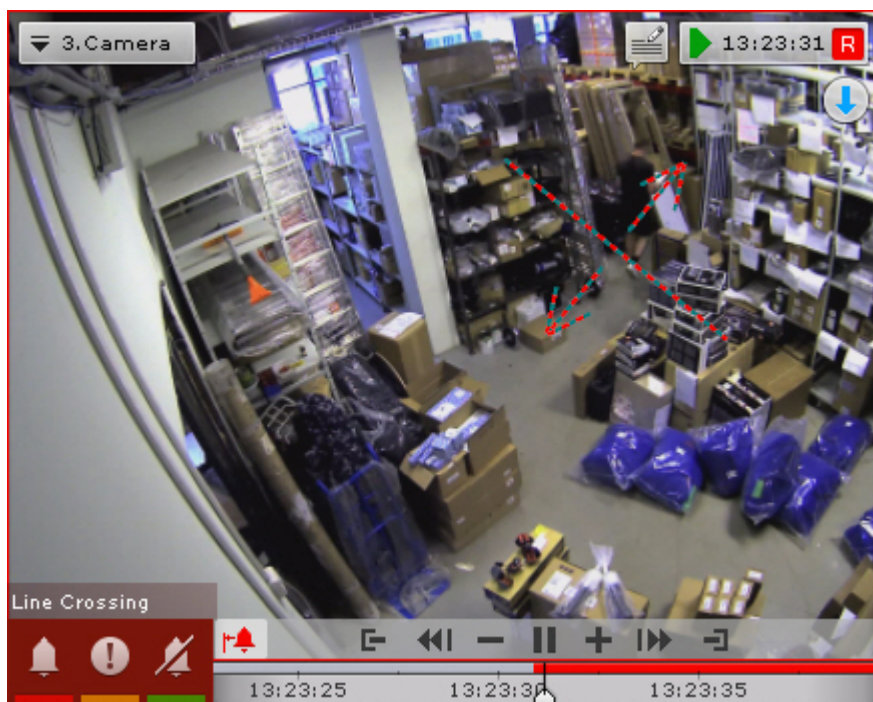

The name of the detection unit that initiated the alarm is displayed in the lower portion of the viewing tile.

To navigate the fragment of an alarm event, use the Advanced Archive Navigation Panel (see [Navigation using the advanced panel](#)) or the Playback Panel (see [Navigating Using the Playback Panel](#)).

To switch to a required fragment of an alarm event in order to play it again, hold the timeline pointer with the left mouse button and drag it to the required position.

To go to the beginning of the alarm event, click .

8.2.5.5.3 Processing an Alarm

To process an alarm, use the group of colored buttons in the lower left-hand corner of the Alarm Management tile. After processing of the alarm, the viewing tile on the given client automatically switches to Live Video mode. The alarm is no longer in the **Alarms** tab.

Attention!

In the case of multi-user event processing, only the first operator to switch to alarm mode may process the alarm (if he or she has the appropriate permissions). For the rest of the operators, the Alarm Management buttons are not displayed.



Button	Executed function
	Confirmed alarm
	Suspicious alarm
	False alarm

8.2.5.6 Limitations when working with alarm events in case of multi-user processing

In the case of multi-user processing, only one operator may accept an alarm for processing. Other operators may switch to alarm mode with limited functions for the purpose of playing back the alarm. This can be done in one of two ways:

1. Click the  button (see the section [Video surveillance in Alarm Management mode](#)).

- Switch to the **Alarms** tab and select the alarm from the alarms list.

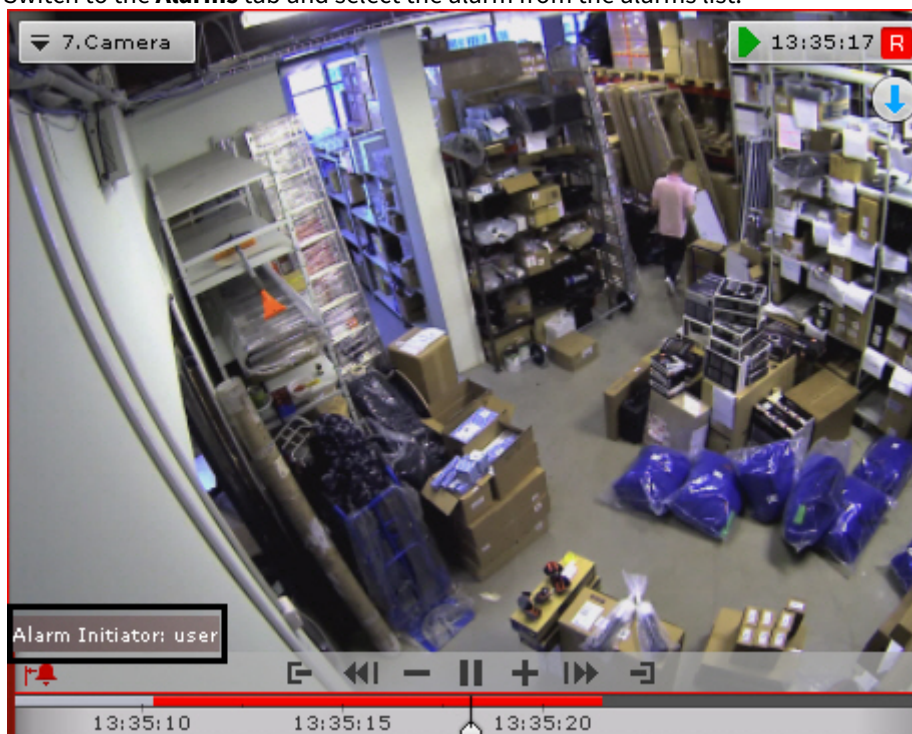

In Alarm Management mode with limited functions, the Alarm Management buttons are not displayed. Instead, the name of the operator who is currently processing the alarm is displayed. The other functions of the alarm handling tile remain unchanged.

After processing of the alarm on another client, on the given client the status assigned to the alarm is displayed in place of the name of the operator.

If a user has accepted an alarm for processing and leaves Alarm Management mode (going to Live Video mode, Archive or Archive Search mode, the viewing tile for another camera, etc.), after an amount of time equal to the operator's idle time after leaving, other users will also have the opportunity to accept the alarm for processing.

If more than one alarm appears for one camera, any operator may access all alarms not yet accepted for processing.

8.2.6 Video surveillance in Archive Search mode

8.2.6.1 Switching to Archive Search mode

To switch the Camera Window from a different surveillance mode to the Archive Search mode, click the **Search** tab in the lower-right corner.

Note

If the video camera is not linked to a video archive, this tab will be unavailable.

Note

In Live Video mode, if the viewing tile is not active, the tabs for switching to other modes are not displayed. To display the tabs, click the viewing tile by using either button of the mouse.



The archive analysis interface will then appear.

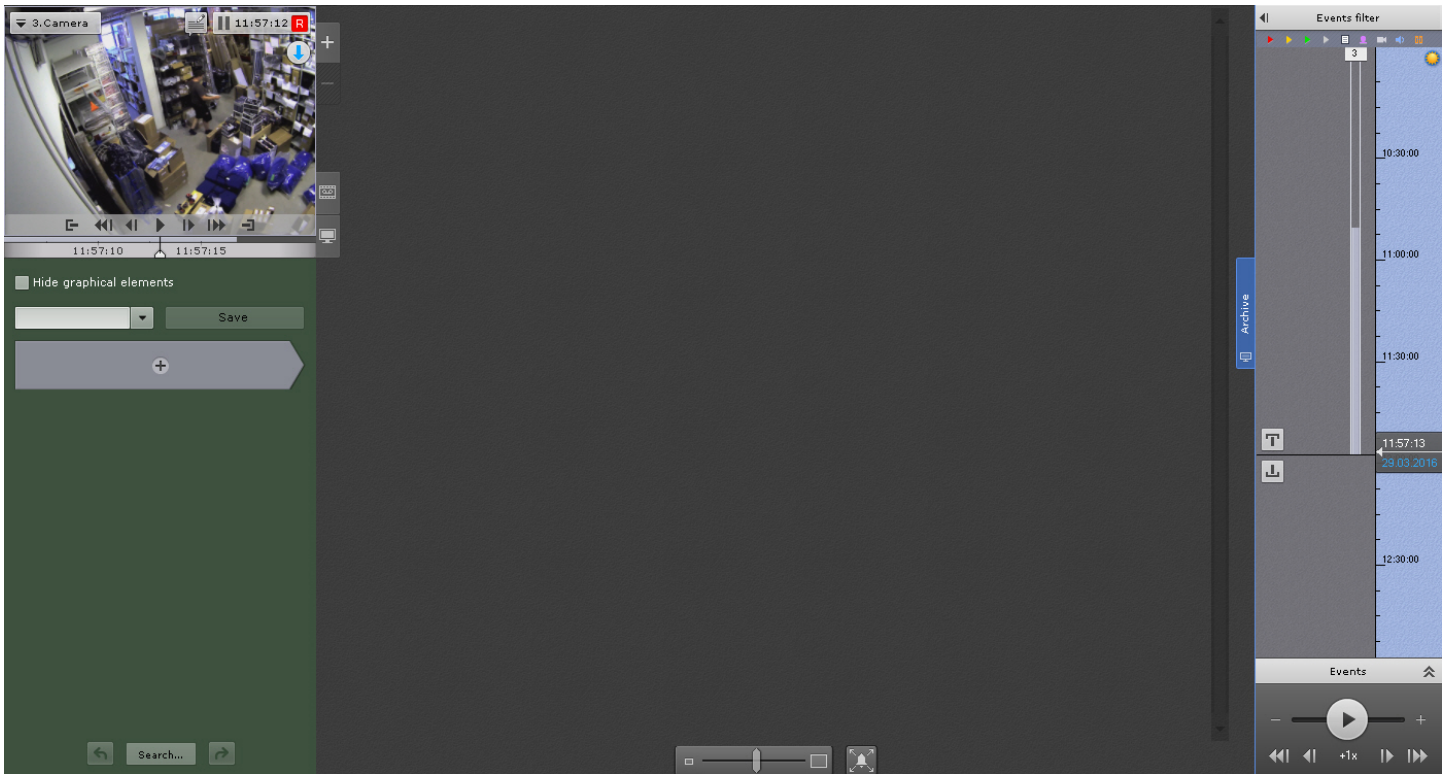

8.2.6.2 Archive Search mode interface

The visual layout of Archive Search mode is divided into the following 4 components:

1. Viewing tile (1, see [Viewing Tile](#))

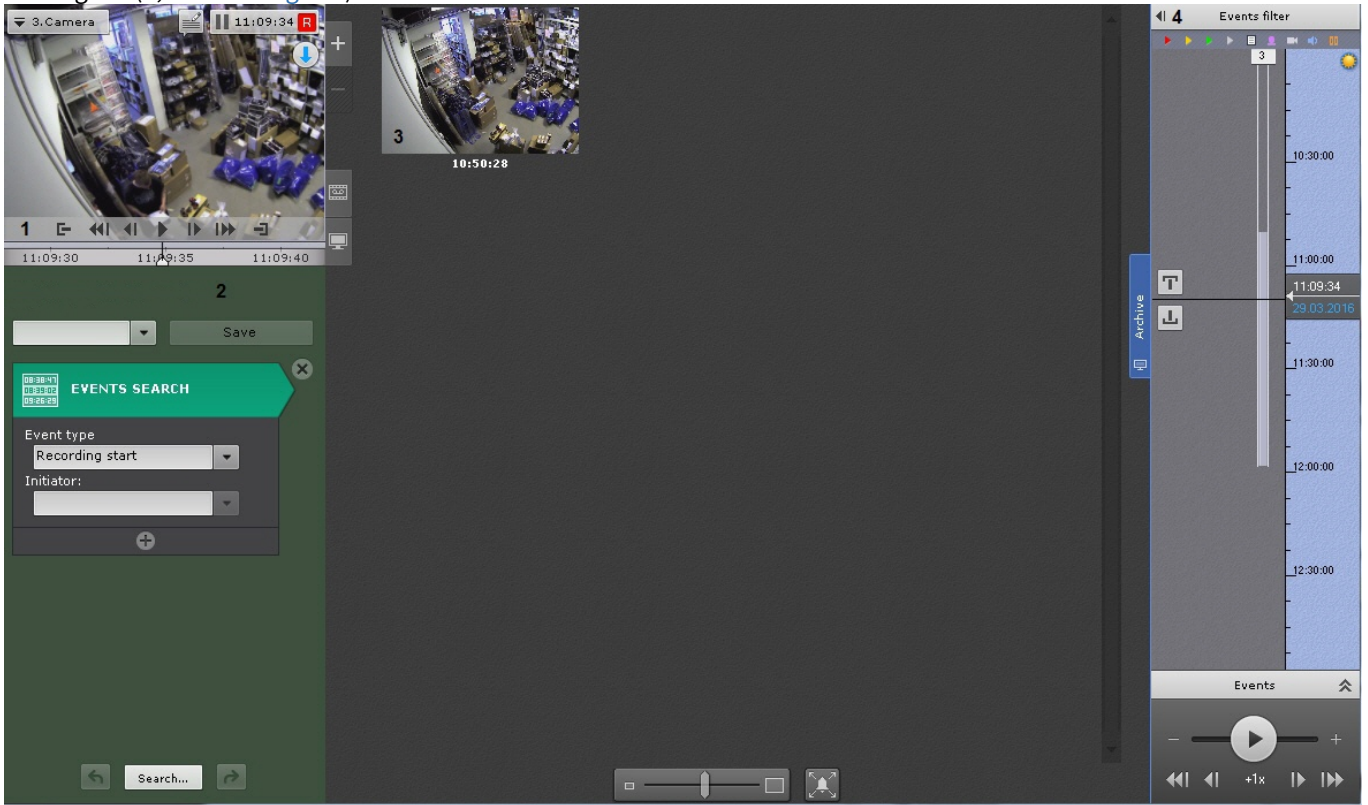

2. Search control panel (2, see [Search in an archive of a single video camera](#))

3. Search results panel (3, see [Viewing search results](#))

4. archive navigation panel (4, see [The Archive Navigation Panel](#))

You can hide search parameters for a portrait-oriented camera. To do so, click the  button.



To unhide, press the  button.

8.2.6.3 Video surveillance functions available in Archive Search mode

In Archive Search mode, the following video surveillance functions are available:

1. Selecting an archive for video recording analysis.
2. Autozoom.
3. Navigating through the archive.
4. Display of the causes of triggered situation analysis detection units.
5. Viewing recorded video with operator comments.

6. Events search.
7. Forensic search.
8. Time search.
9. Searching comments.
10. Switching between search results.
11. Playing back fragments retrieved by searches of specific moments in time.
12. Zooming in on objects that trigger detection tools.
13. [Functions Available in All Video Surveillance Modes.](#)

Note

The functions for navigating through an archive, displaying the causes of situation analysis detection unit triggering, and **Archive Selection** were inherited from archive mode; their descriptions are [Video surveillance in archive mode](#). The Autozoom function is described in the [Real-time video surveillance](#) section.

8.2.6.4 Search in an archive of a single video camera

8.2.6.4.1 Selecting the search type

To start a search, click  and choose the search type.

Events Search	
Line crossing	Metadata search
Motion in area	Metadata search
Loitering	Metadata search
Multiple objects	Metadata search
Move from area to area	Metadata search
Thumbnail Search	
Comments Search	
Search by titles	
Search by LPs	
Face Search	

Note

The current *Axxon Next* suite release supports only search of a single type at one time.

Note

In the on-board storage of the camera, you can only find video episodes with thumbnail search (TimeSlice).



8.2.6.4.2 Setting a search interval

Setting a search interval follows the same procedure for all types of archive search.

By default, the search spans across video footage / archive tracks currently displayed on the timeline (see [Navigating Using the Timeline](#)).

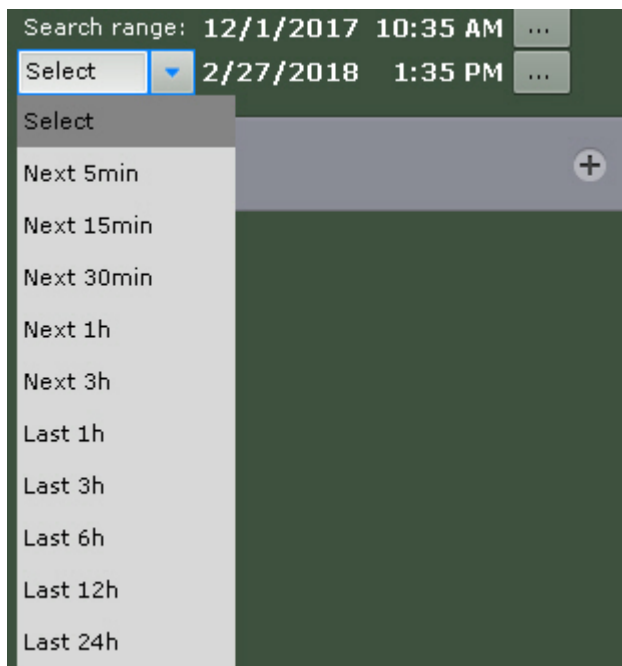
To alter the search interval, select the desired value from the **Search Range** dropdown list.



Search Range	Description
Whole Archive	Searches are performed across the entire Archive.
Timeline	Searches span across Archive tracks currently displayed on the timeline.
Range	Searches are performed within the interval currently selected on the timeline. You can set an interval using  and  buttons.
Last 1h/3h/6h/12h/24h	The searches will be performed within the last hour (or 3, 6, 12, 24 hours) of recorded footage.
Next 5min /15min /30min /1h /3h	The searches will be performed within the following interval: [specified start of the interval; specified start of the interval + 5min / 15min / 30min / 1h / 3h]. To set the beginning time of the interval, click  .

8.2.6.4.3 Events search

This type of search lets you select events in the archive based on the type of event.

To do this, complete the following steps:

1. Choose the type of events to search for moments (1).

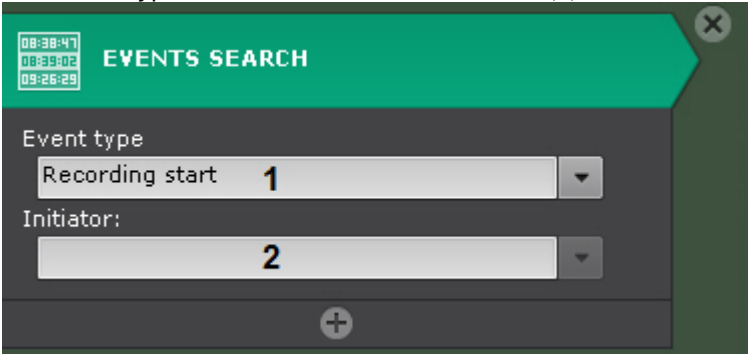

Event	Description
All alarms	The search finds moments in the archive containing all types of alarms
Non-critical alarm	The search finds moments in the archive containing non-critical alarms
Critical alarm	The search finds moments in the archive containing critical alarms
Unclassified alarm	The search finds moments in the archive containing unclassified alarms
False alarm	The search finds moments in the archive containing false alarms
Triggering	The search finds moments when detection units were triggered
Recording start	The search finds the beginning and end of recordings from the specified video camera regardless of the initiator

2. Select an event initiator from a list with the same name (2).

Note

An event initiator could be an operator, a video camera input, or any detection unit that is activated in the system. The search results will show the moments in time containing the events that were triggered by the initiator.

3. If necessary, click **+** and add more similar search conditions.
4. Set the search interval (see [Setting a search interval](#)).
5. Click the **Search** button.

Note

Once launched, the search can be stopped at any time. To do this, click the **Stop** button which appears instead of the **Search** button.

This starts a search in the archive based on the defined criteria. Search results are available on the search results panel.

Note

To zoom objects that caused an alarm or triggered a detection unit, select the **Expand alarm object** check box in the lower portion of the search results panel.

8.2.6.4.4 Time search for video fragments (TimeSlice)

The search of fragments by time is meant for quick search of moment of interest by dividing a selected time period into equally sized fragments.

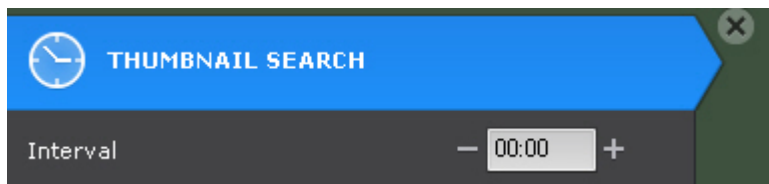

Search by time is performed using the following algorithm:

1. **Setting a search interval.**
2. In the **Interval** field, specify the duration of the video episodes in the MM:SS format:
 - a. If you do not specify the duration (00:00), Time Slice (Thumbnail Search) splits video footage from the selected time interval into 12 equal episodes.
 - b. If you set the duration other than 0, Time Slice splits the selected time interval into video clips of the specified duration. The number of slices depends on the specified parameters.

Note

It's recommended to set the interval value to no less than 10 seconds.

3. Start the first search iteration (click the **Search** button).

Note

Once launched, the search can be stopped at any time. To do this, click the **Stop** button which appears instead of the **Search** button.

The search results panel displays frames that match moments in time that are equally spaced from each other; the search control panel shows the number of fragments found.



4. If the specific moment is not found, then start the second search iteration: double-clicking on the found moment triggers the search in the time interval from this moment to the next one.
5. Keep searching until the specific moment is found.

Note

Information on playback of video fragments is provided in the section titled [Playback of video fragments](#)

8.2.6.4.5 Searching comments

Comments search allows filtering for comments that contain certain text.

To search comments:

1. Set the search interval (see [Setting a search interval](#)).
2. Enter the text that you want to find in comments.

Attention
Search is performed for the entire string of entered text, not for separate words.

Note
If no text is specified, all comments for the selected interval are found.

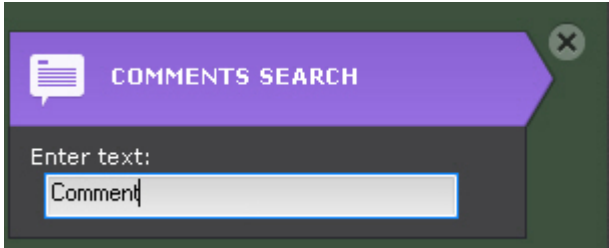

3. Click the **Search** button.

Note
Once launched, the search can be stopped at any time. To do this, click the **Stop** button which appears instead of the **Search** button.

This starts a search for video fragments based on the defined criteria. The search results pane displays frames for which there are comments containing the search text. The relevant comment is displayed under each frame.

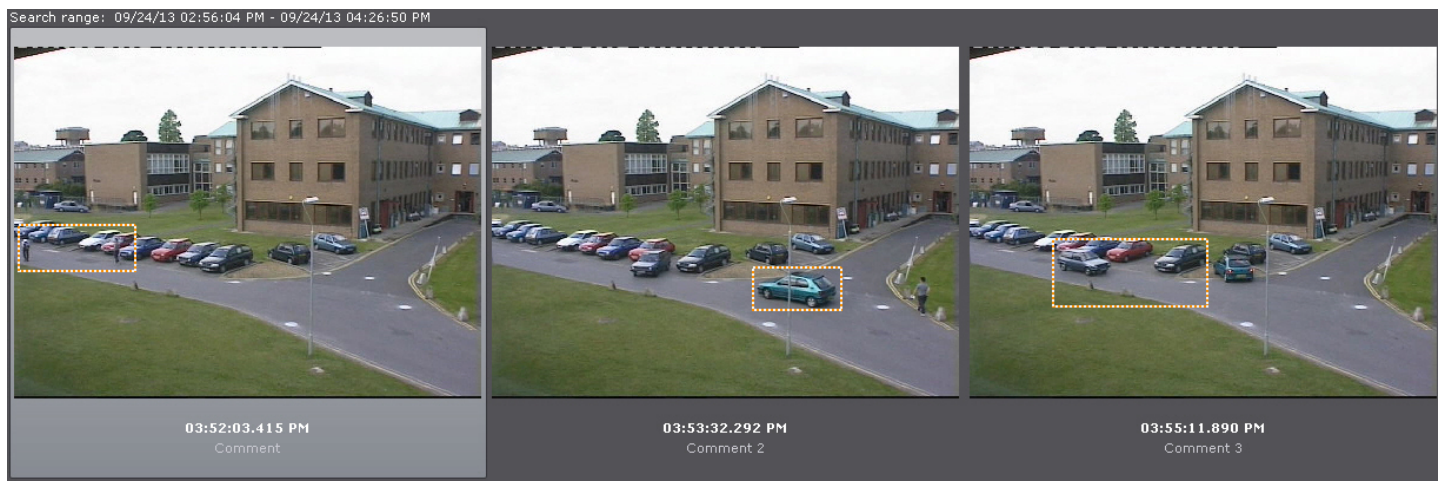

Note
If the comment was left for an interval, the first frame of the interval is displayed.

8.2.6.4.6 Forensic Search for Fragments (MomentQuest)

Forensic Search lets you search for moments in the archive using the following criteria:

1. Motion in Area.
2. Loitering of an object in a specific area.
3. Simultaneous presence of a large number of objects in a specific area.
4. Crossing of a virtual line by an object's trajectory.
5. Motion from one area to another.

8.2.6.4.6.1 Motion in Area

To perform forensic search for motion in area:

1. In the Viewing Tile, define the area to be analyzed during search in accordance with the selected condition. The nodes of an area are connected by a two-colored dotted line. By default, an area is defined by 4 nodes with the coordinates (30%, 30%), (70%, 30%), (70%, 70%) and (30%, 70%) as percentages of the width and height of the frame, respectively.

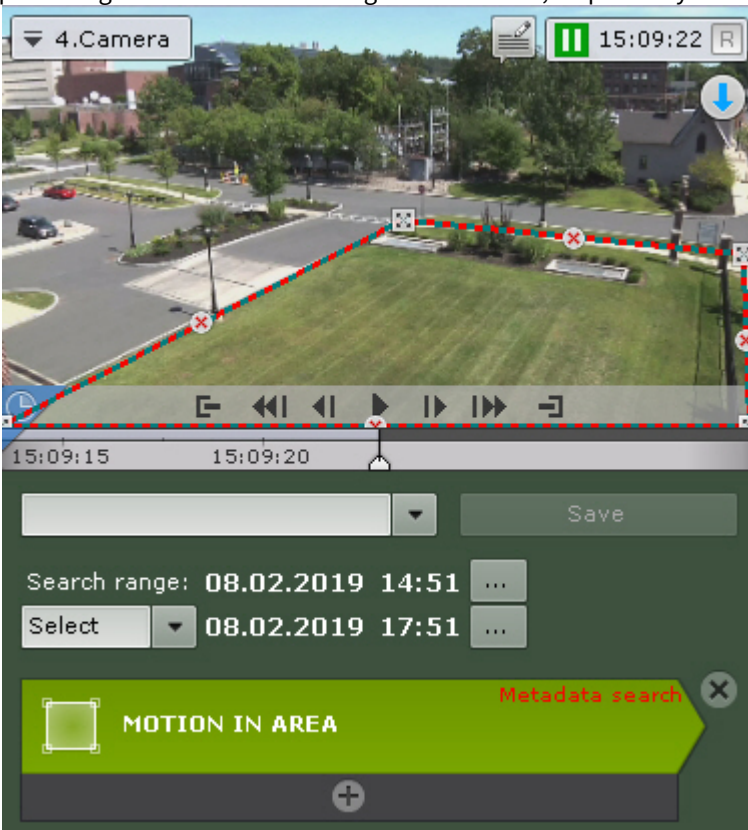

To edit an area, use the following actions.

Action	Result
Right-click on a line	Creates a new area node
Right-click on a created node	Deletes the area node
Position the cursor on a node and hold down the left mouse button while you move the mouse	Moves the area node

2. Select the metadata source if there are several for this video camera. This parameter will not be displayed if there is only one source.
3. Specify any number of additional parameters by clicking , if necessary (see [Configure the search parameters](#)).
4. Set the search interval (see [Setting a search interval](#)).
5. Click the **Search** button.

Note

Once launched, the search can be stopped at any time. To do this, click the **Stop** button which appears instead of the **Search** button.

The found moments will be displayed in the search results panel.

8.2.6.4.6.2 Loitering of an object in a specific area

To search for moments of an object loitering in an area:

1. In the Viewing Tile, define the area to be analyzed during search in accordance with the selected condition (see [Motion in Area](#)).
2. Select the metadata source if there are several for this video camera (1). This parameter will not be displayed if there is only one source.

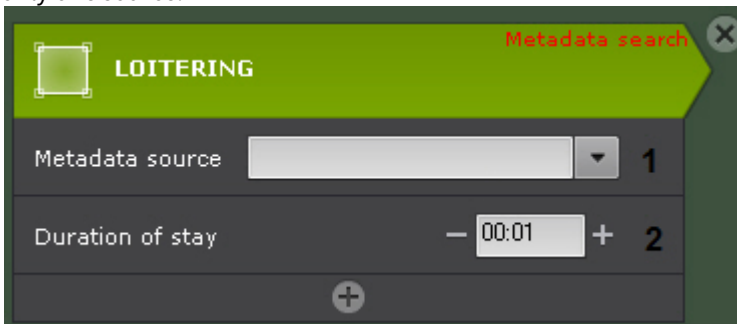

3. Set the minimum duration of stay in the area (2, in seconds and minutes). Search results contain recorded video in which the object is present in the area for longer than the indicated time.
4. Specify any number of additional parameters by clicking **+**, if necessary (see [Configure the search parameters](#)).
5. Set the search interval (see [Setting a search interval](#)).
6. Click the **Search** button.

Note

Once launched, the search can be stopped at any time. To do this, click the **Stop** button which appears instead of the **Search** button.

The found moments will be displayed in the search results panel.

8.2.6.4.6.3 Simultaneous presence of a large number of objects in a specific area

To search for moments when objects gather in an area:

1. In the Viewing Tile, define the area to be analyzed during search in accordance with the selected condition (see [Motion in Area](#)).
2. Select the metadata source if there are several for this video camera (1). This parameter will not be displayed if there is only one source.



- Specify the number of objects allowed in the area (2). Search results contain recorded video in which the number of objects in the area exceeds the specified number.
- Specify any number of additional parameters by clicking , if necessary (see [Configure the search parameters](#)).
- Set the search interval (see [Setting a search interval](#)).
- Click the **Search** button.

Note

Once launched, the search can be stopped at any time. To do this, click the **Stop** button which appears instead of the **Search** button.

The found moments will be displayed in the search results panel.

8.2.6.4.6.4 Motion from one area to another

To search for moments when the object moves from one area to another:

- Set two areas in the Viewing Tile: the area the object moves from and the one it moves to.
The nodes of each area are connected by a two-colored dotted line. The direction of motion between the areas is indicated by a dotted arrow.
By default, each area is defined by 4 nodes. The nodes of the first area have the coordinates (20%, 40%), (40%, 40%), (40%, 60%), (20%, 60%), and those of the second have the coordinates (60%, 40%), (80%, 40%), (80%, 60%), (60%, 60%) as percentages of the width and height of the frame, respectively.

Note

You can collapse the graphical elements if they block the visual elements and prevent editing them. To hide them, select the **Hide graphical elements** check box.

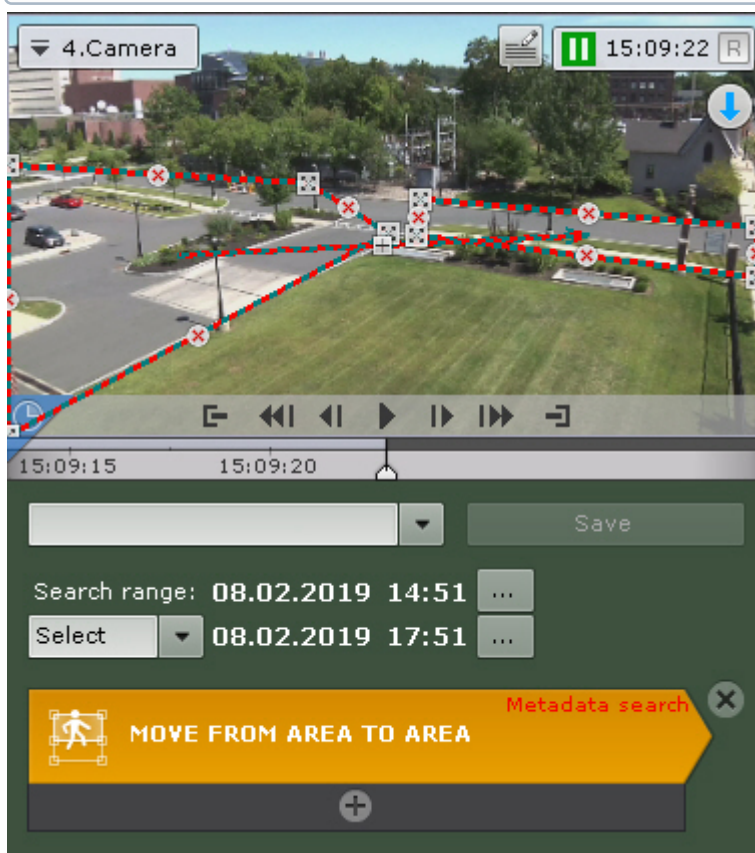

Area editing operations are described in the [Motion in Area](#) section.

To change the direction of motion between the areas, click the  button on the direction arrow.

2. Select the metadata source if there are several for this video camera. This parameter will not be displayed if there is only one source.
3. Specify any number of additional parameters by clicking , if necessary (see [Configure the search parameters](#)).
4. Set the search interval (see [Setting a search interval](#)).
5. Click the **Search** button.

Note

Once launched, the search can be stopped at any time. To do this, click the **Stop** button which appears instead of the **Search** button.

The found moments will be displayed in the search results panel.

8.2.6.4.6.5 Crossing of a virtual line by an object's trajectory

To search for moments when the object crosses a virtual line:

1. Set the virtual line to be crossed in the Viewing Tile.
The end points of the line are connected by a two-colored dotted line. The direction of the object's motion across the line is indicated by dotted arrows.
By default, the end points of the line have the coordinates (50%, 30%) and (50%, 70%) as percentages of the width and height of the frame, respectively.

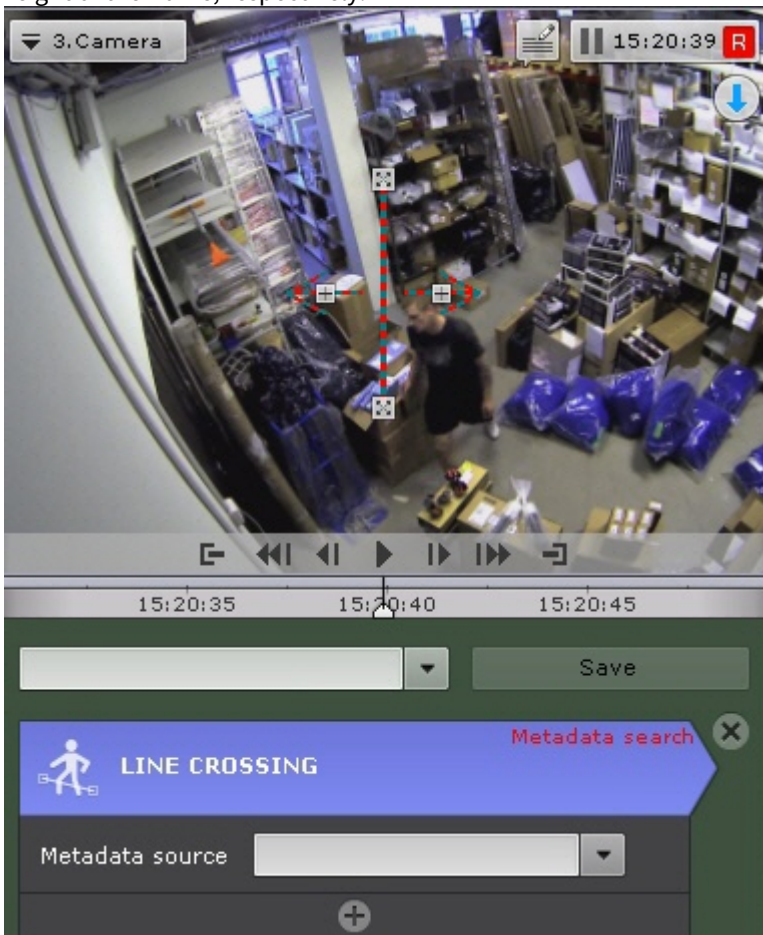

To move the end point of a line, position the cursor on the end point and hold down the left mouse button as you move the mouse.

By default, both directions of motion across the virtual line are taken into account when searching the archive. If you do not need to search in a specific direction, click the  button corresponding to that direction.

Attention!

At least one direction must be selected for the search.

Note

A disregarded direction of object motion is indicated by a dimmed arrow.

2. Select the metadata source if there are several for this video camera. This parameter will not be displayed if there is only one source.
3. Specify any number of additional parameters by clicking , if necessary (see [Configure the search parameters](#)).
4. Set the search interval (see [Setting a search interval](#)).
5. Click the **Search** button.

Note

Once launched, the search can be stopped at any time. To do this, click the **Stop** button which appears instead of the **Search** button.

8.2.6.4.6.6 Configure the search parameters

It is not required to specify parameters, but for more precise results, it is possible to set one or more parameters for each criterion:

The search criteria	Possible parameters
Motion in Area	Direction of movement Maximum and minimum object size Maximum and minimum object speed Object color Object type Entry/exit from area
Loitering in area	Maximum and minimum object size Object color Object type
Many objects in area	Maximum and minimum object size Object color Object type
Object trajectory crossing a virtual line Motion from area to area	Maximum and minimum object size Maximum and minimum object speed Object color Object type

Configuring minimum and maximum object size

The procedures for setting the minimum and maximum size of a moving object are identical.

The minimum (or maximum) size of a moving object can be set using any of the following methods:

Note

The first method lets you roughly configure the size, and the second method allows you to set the size precisely.

1. Position the cursor on a visual element node and hold down the left mouse button while moving the mouse (**1**).

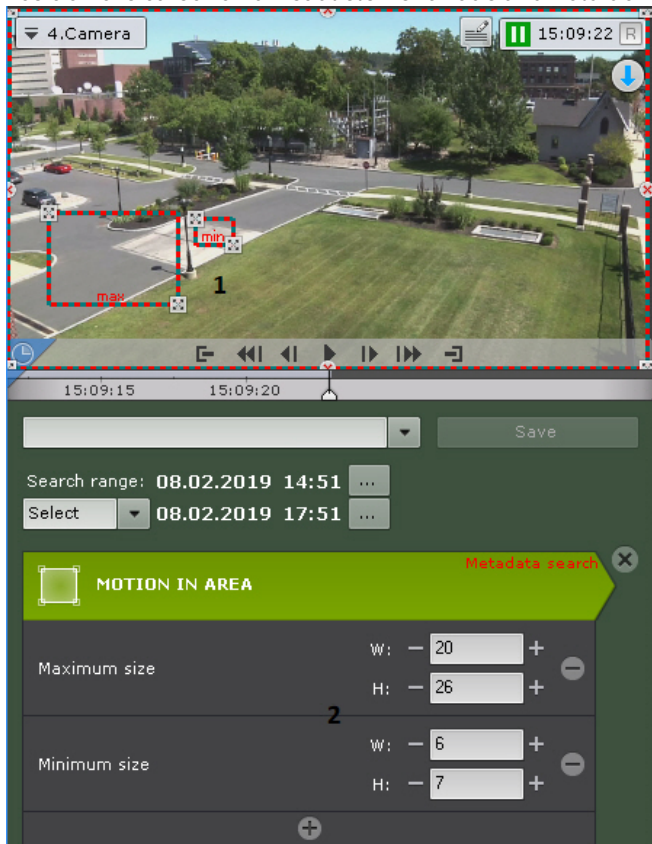

2. Set the width and height of an object of the minimum (maximum) size using the arrows in the upper and lower margins, respectively. The dimensions of a visual element in the viewing tile can be changed in a similar manner (**2**).

The minimum (maximum) size of an object is now set.

Configuring minimum and maximum object speed

In the *Axxon Next* VMS, the speed is a relative value computed from parameters of different units. The computing algorithm includes both frame width and height. For more accurate search, we recommend you to perform several search iterations while setting speed values empirically.

The procedures for setting the minimum and maximum speed of a moving object are identical.

The minimum (or maximum) speed of a moving object can be set using any of the following methods:

1. Position the cursor on an end point of the arrow and hold down either mouse button while you move the mouse. The length of the arrow will correspond to the minimum (maximum) displacement of the object per second (1).

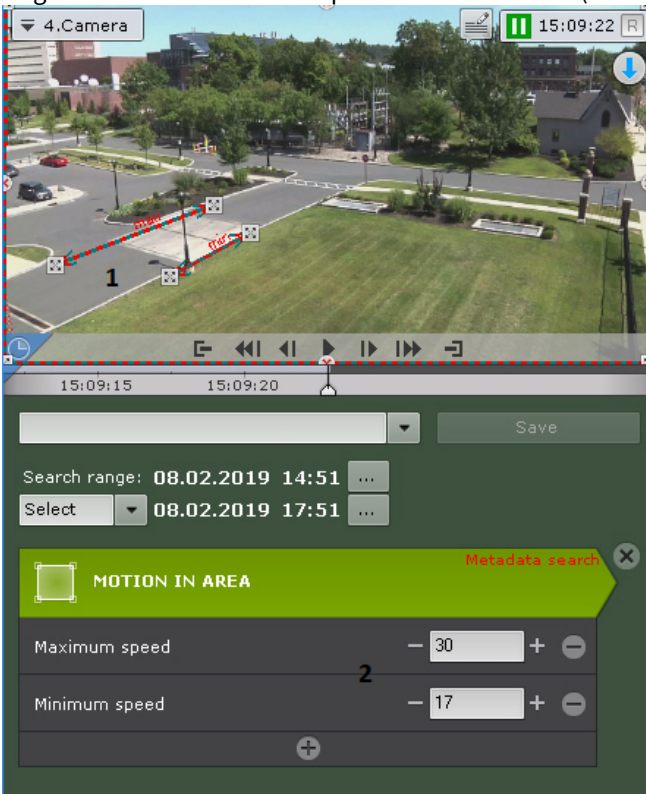

2. Use the arrows to set the minimum (maximum) speed of the object as percentages of the frame per second (2).

The minimum (maximum) speed of a moving object is now set.

The following objects will be included in the search results:

- If you set only the maximum speed - the objects that move slower, than the maximum speed.
- If only the minimum speed is specified - the objects that move faster than the minimum speed.
- If both the maximum and the minimum speed are specified - the objects whose speed does not exceed the maximum, but is more than the minimum speed.

Configuring object color

The color range is selected using drag and drop on the color palette (click and hold either mouse button, move the mouse, then release the button).

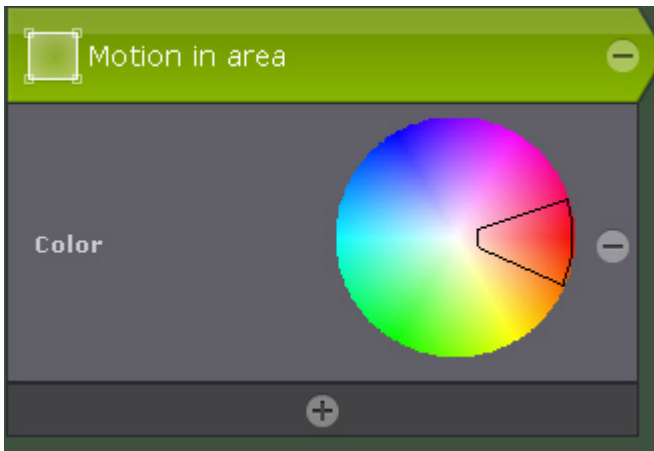

Any click on the palette is interpreted as the beginning of a new range; the previous range will disappear.

Attention!

The Axxon Next's inner logic treats all objects as monochrome. The object color is averaged within the object's contour. All objects of specified colors will appear in search results.

Configuring direction of object movement

By default, when searching the archive, the system searches for motion in all directions. It is possible to prevent searching for motion in one or several specific directions.

Click with either mouse button to designate a direction in which you do not want to perform movement search (privacy mask). The sector corresponding to the direction is then colored gray. If necessary, repeat this action for other directions. To reactivate searches for a masked (gray) direction, click it again with either mouse button.



The required directions of an object's movement are now set.

Configuring object entry/exit from area

"Entry" occurs when an object enters the field of view and crosses its boundaries; "exit" occurs when an object disappears from the field of view and crosses its boundaries.

To find moments when an object enters an area, select **Enter**, or for moments when an object exits an area, select **Exit**.

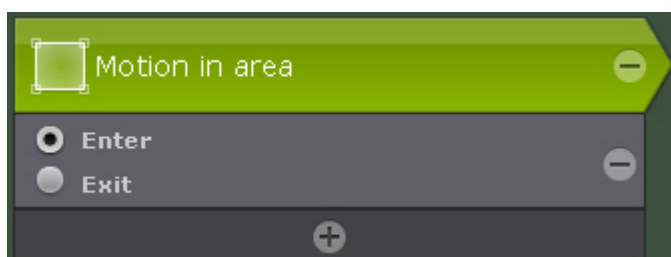
**Choosing the object type**

You can search for moving objects of one or several types: a person, a group of people, a vehicle, or an item left behind. To do this, check the corresponding boxes.

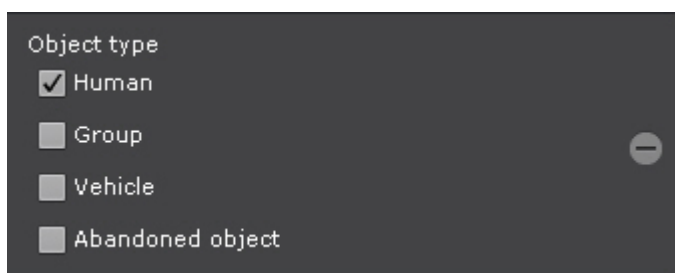

Note

The object type is determined by analyzing its appearance. An item that does not move for some time is considered to be abandoned, e.g. a parked car.

Attention!

You cannot search by object type in VMD-generated metadata (see [Setting up VMD-based Scene Analytics](#)).

8.2.6.4.7 Titles search

You can search for keywords in the titles DB.

To search the titles DB, do as follows:

1. Set a time interval for your search (see [Setting a search interval](#)).
2. Enter the text that you want to find in the titles. You can search the whole word or part of it.

Attention!

Search is performed for the entire string of entered text, not for separate words.

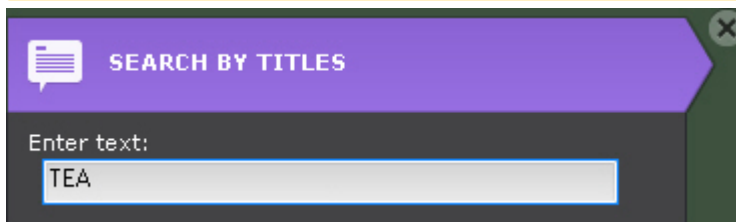

3. Click the **Search** button.

Note

Once launched, the search can be stopped at any time. To do this, click the **Stop** button which appears instead of the **Search** button.

This starts a search for video fragments based on the defined criteria. The search results pane displays frames for which there are titles containing the keywords.

Attention!

When you search for events, the event time corresponds to the start time of the receipt, rather than the time of occurrence of the search text.

8.2.6.4.8 LPR search

With LPR search you can find video footage for the recognized number plates.

To search recorded video for LPR results:

1. Set a time interval for your search (see [Setting a search interval](#)).
2. Enter the number plate. Fuzzy search supported if you enter the number with the ? mask for any one character, and the * mask for any number of characters) For example, a search query ?20* will show all vehicles with license plate containing 2

and 0 in the second and third position respectively. The total number of characters in number plates will be variable.

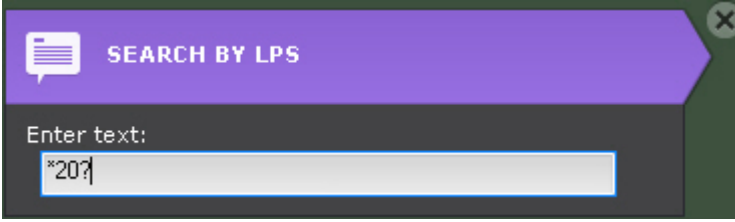

3. Click the **Search** button.

Note

Once launched, the search can be stopped at any time. To do this, click the **Stop** button which appears instead of the **Search** button.

This starts a search for video fragments based on the defined criteria. The search results pane displays frames for which there are number plates containing the search text.

A recognized number plate will be highlighted by a red frame in the Viewing Tile.



8.2.6.4.9 Face search

Face search allows to find faces similar to a given photo in an archive.

If you perform facial search via the camera window, face track and dimensions are always highlighted.



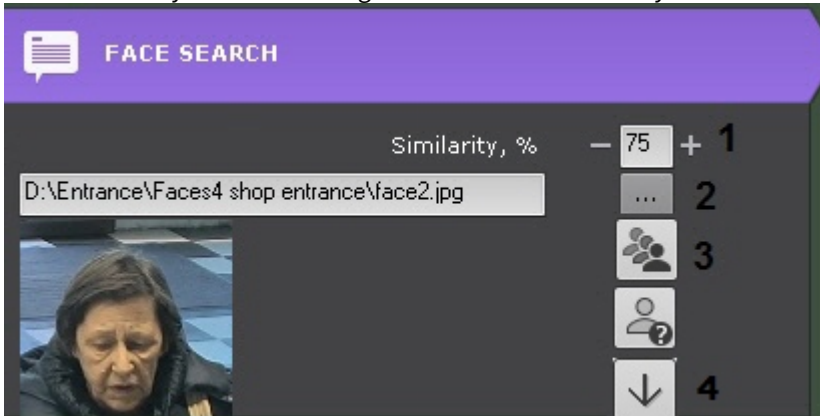

To perform face search:

1. Set the search interval (see [Setting a search interval](#)).
2. Set the minimum similarity level (in %) between the face in the photo and faces from the archive (1). The search results will contain only the video footage with faces with similarity levels above the set value.



3. Select a photo with the face to be searched for in the archive (2). Supported formats: **png, jpg, jpeg, jpe**. Clicking on a face will select this face as a search parameter. If you do not select a photo, then all faces recognized during the specified time will be displayed.

4. Select, how to sort search results:  - by the face match;  - by time (3).
5. Click the **Search** button.

Note

Once launched, the search can be stopped at any time. To do this, click the **Stop** button which appears instead of the **Search** button.

This starts a search in the archive based on the defined criteria.

The video frames with faces satisfying search conditions will be displayed in the search results panel. A recognized face will be highlighted with a red frame, and the face similarity level(in %) will be shown below.

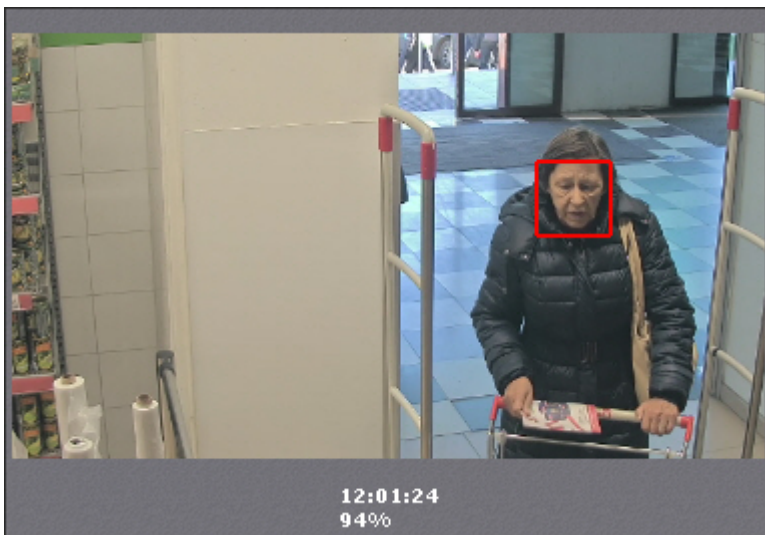

To instantly export a facial image from the scene, do the following:

1. Click a face track within the camera window.

2. Click the button  (4).

The facial image will be saved to a pre-specified folder (see [Configuring export options](#)).

8.2.6.4.9.1 Tell "friend" from "foe" by a picture

To determine the "friend"- "foe" status, do as follows:

1. Select a photo (1).

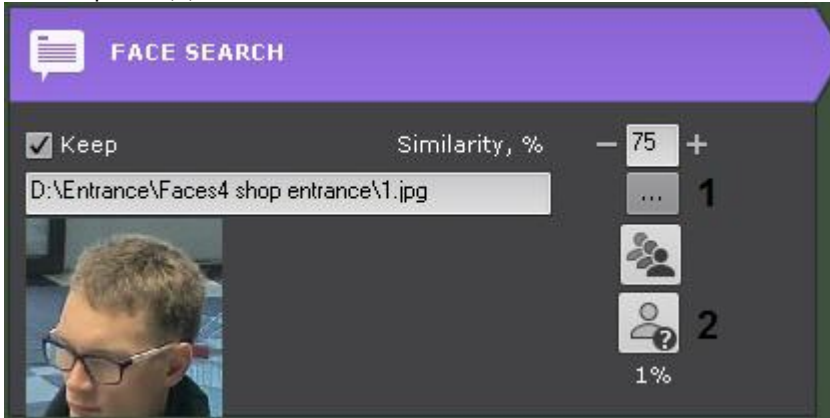

2. Click the  button.

The Search bar (2) will display the probability that the person is a "stranger".

The algorithm is as follows:

1. The person is compared to all the recognized persons in the last 30 days.
2. The number of days (N) in which the person was captured by camera and recognized is calculated.
3. The probability is calculated according to the formula $(1-N/30) * 100$.

8.2.6.4.10 Saving search queries

Saving a search query allows you to:

- quickly retrieve its results;
- apply search criteria to other cameras.

To save a search query, specify a name (1) and click the **Save** button (2). After this, the tab for the search query becomes available in the lower-right corner of the viewing tile in Archive mode (see [Viewing the results of a saved search query](#)).

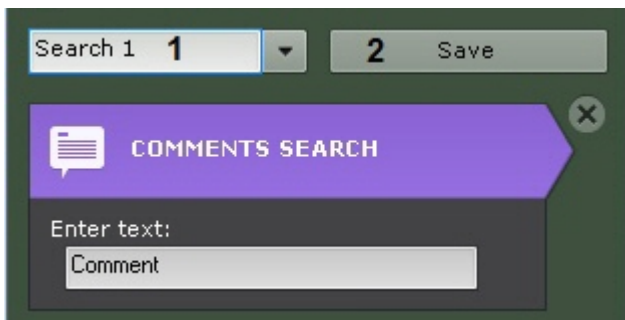

Attention!

The search range can not be saved.

To apply the saved search criteria to another camera's archive, switch the camera to Archive Search mode and select the required search query.

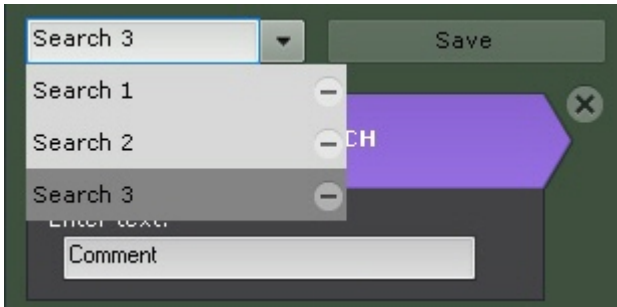

To edit a search query, view the list and select the relevant query.

Changes are not saved until the **Save** button is clicked. If the query name is changed, the query is saved under the new name and the old, unchanged query remains available.



To delete a search query, click the  button.

8.2.6.4.11 Switching between search results

If a search was run more than once and the user did not exit Archive Search mode during that time, it is possible to switch between search results.

Note

The number of stored results is limited only by the amount of RAM in the server.

Click  on the search control panel to switch to the previous search result, and click  to switch to the next result. Each time you switch between results, the search results panel displays the moments corresponding to the previous/next result.

8.2.6.4.12 Working with search results

8.2.6.4.12.1 Viewing search results

The Search Control Panel shows how many episodes are found when the search is complete.



The search results panel displays the precise moments in an archive that correspond to the defined search criteria. The precise time of each moment is displayed underneath (1).

Note

An alarm object is outlined in red.

Note

To copy the time and the start date of the video fragment to the Clipboard, right-click on them.



A scroll bar is located on the right side of the search results panel (2). Beneath is a time scale adjuster (3).

If you choose a spot on the the timeline, the search results are automatically sorted. The closest episode will be highlighted in search results.

You can filter the search results and keep only the important episodes. To do this:

1. Double-click the episode, that you want to keep. Its thumbnail is tagged with a star .

Note

To remove the tag, click the star again .

2. Tag all the episodes you want to keep.

3. Click **Clear** to delete untagged episodes from the search results.



8.2.6.4.12.2 Viewing Search Results In TimeCompressor

When you search recorded video for motion events by metadata (LPR search, Face search, Forensic Search for Fragments (MomentQuest)), you can view results in the TimeCompressor mode.

To do this, click the  button on the timeline in the camera window.

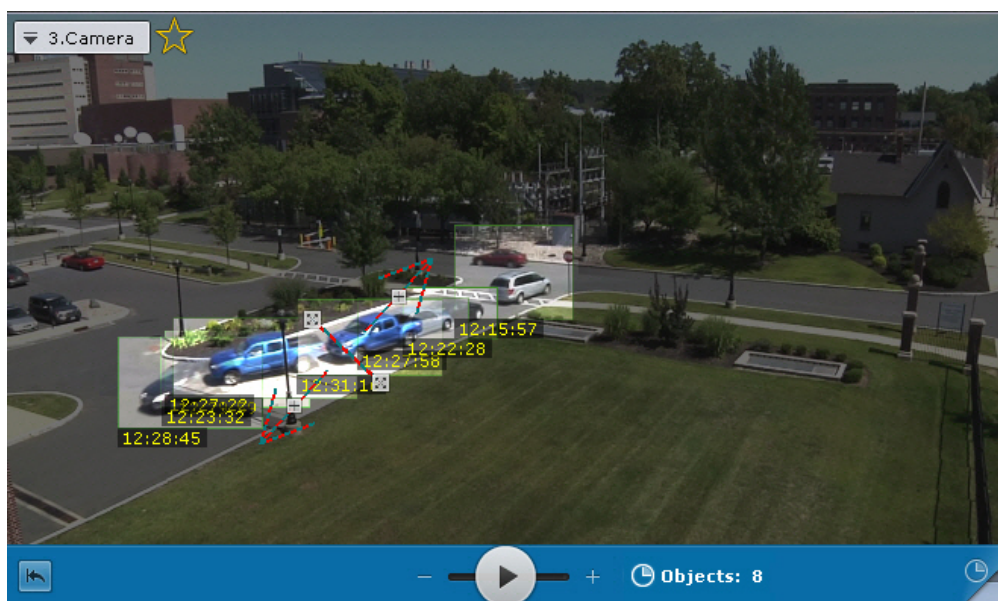

8.2.6.4.12.3 Playback of video fragments

To view the video fragment corresponding to a found moment in the archive, complete the following steps:

1. Left-click the found moment on the search results panel.

2. Using the playback panel (1), start playback of the fragment in the viewing tile (2).

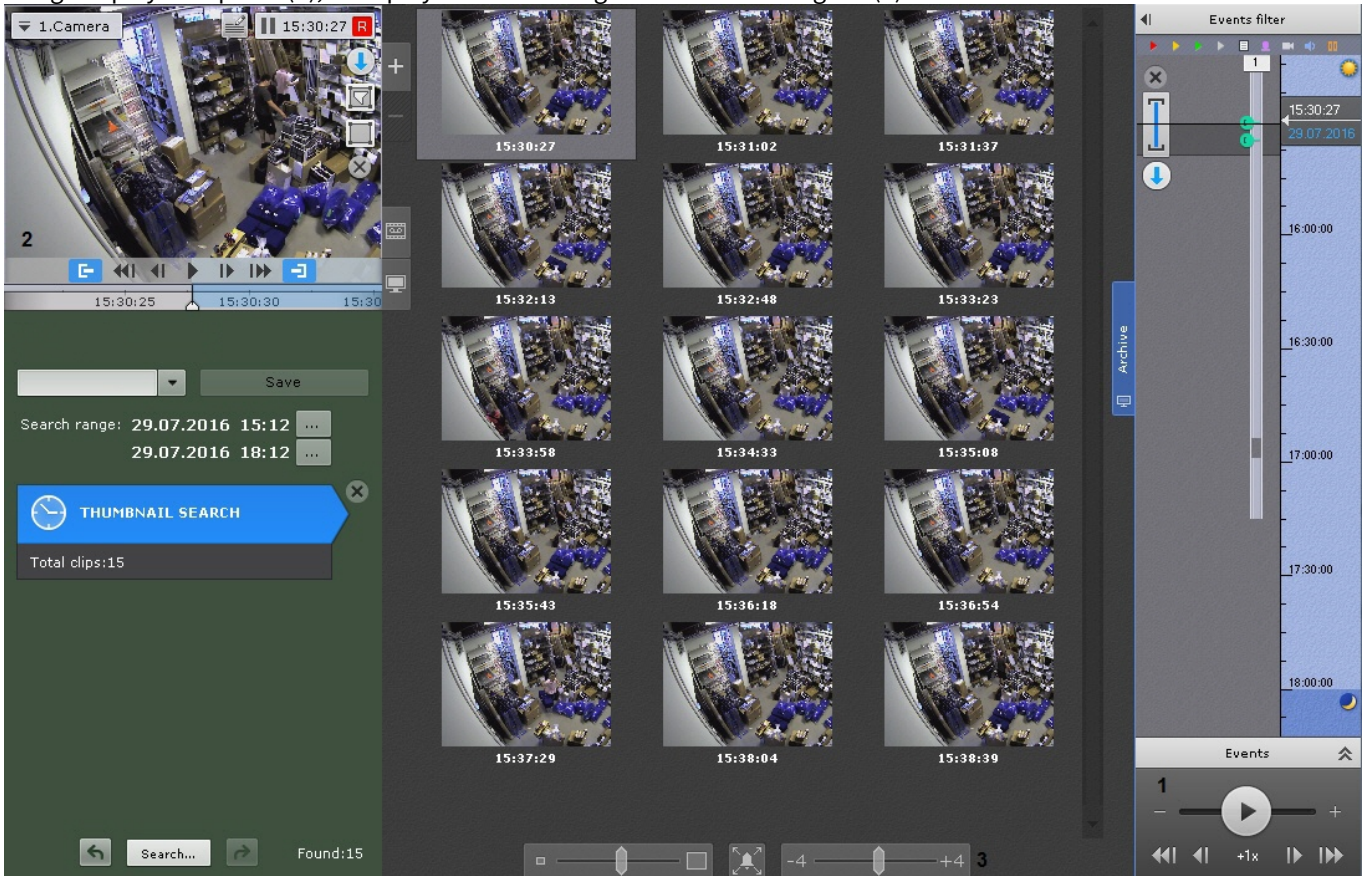

By default, the playback starts with the time specified under the thumbnail. You can use the control (3) to change the start time. If the control is in the leftmost position, playback starts 4 seconds earlier than the start time. If the control is in the far right position, playback starts 4 seconds later.

Note

If object tracking is activated in the viewing tile, then the properties of tracked objects (width and height as a percentage of the width or height of the frame) are displayed when viewing video fragments found through forensic search.

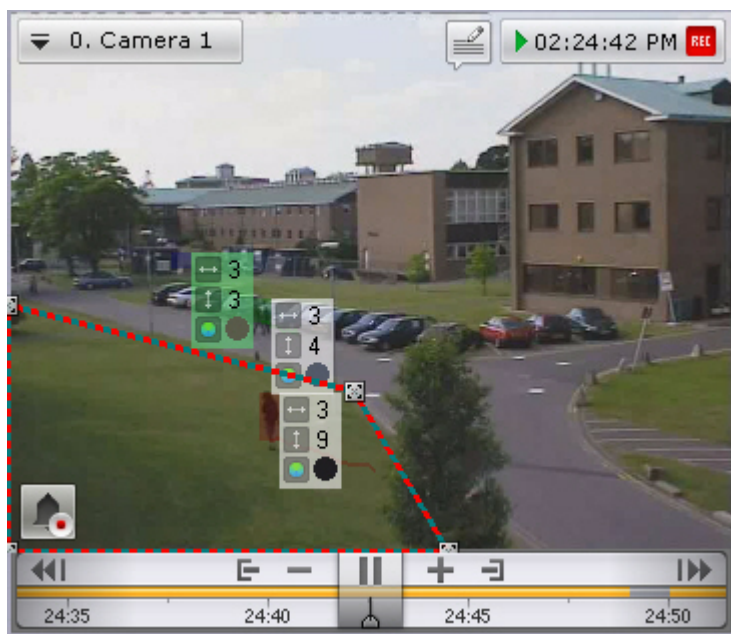

Note

To switch between video fragments, use the corresponding buttons on the playback panel or on the advanced navigation panel (see the sections titled [Navigation using the advanced panel](#) and [Navigating Using the Playback Panel](#)).

Extreme zooming a camera window makes the Search Conditions and Archive Navigation panels become hidden (see [Scaling the Viewing Tile](#)).

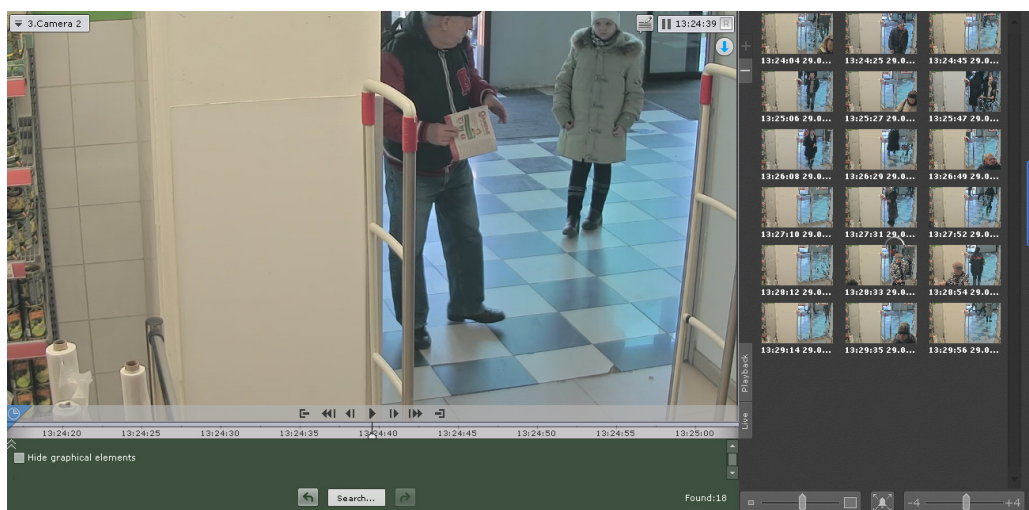

8.2.6.4.12.4 Enlargement of found moments

When you find moments in archive video, you can enlarge the following:

- Object that triggered the detection tool (during event search).
- Track (during forensic search).
- Commented area of the frame (during comment search).

To do so, above the search results, click the  button.

**Attention!**

Enlargement occurs only in the following cases:

1. If the height and width of the visual item specified in the forensic search settings is less than 1/3 of the frame dimensions.
2. If the tracking object occupies less than 1/3 of the frame (for detection tool search)
3. If the object marked by the comment occupies less than 1/3 of the frame (for comments search)

In all other cases, the found moments are displayed in their entirety.

To close zoom, click the  button again.

8.2.6.4.12.5 Exporting the video fragments and repeated search

To export the video fragment corresponding to a found moment in the archive:

1. Double-click the found moment on the search results panel. The interval for export will be set apart from this moment until the next found moment.

Important

Double-clicking the found moment will also cause a repeated search within the selected time interval for export.

2. Export the video (see [Exporting Video Recordings](#)).

8.2.6.5 Simultaneous search in an archive of several video cameras

Attention!

The number of video cameras for search is not limited.

To search multiple cameras' Video Footage, do the following:

1. Choose your desired search type and criteria (see [Search in an archive of a single video camera](#)).

- In the Camera Search Panel, check the cameras where Video Footage search has to be performed (see [Camera Search Panel](#)).

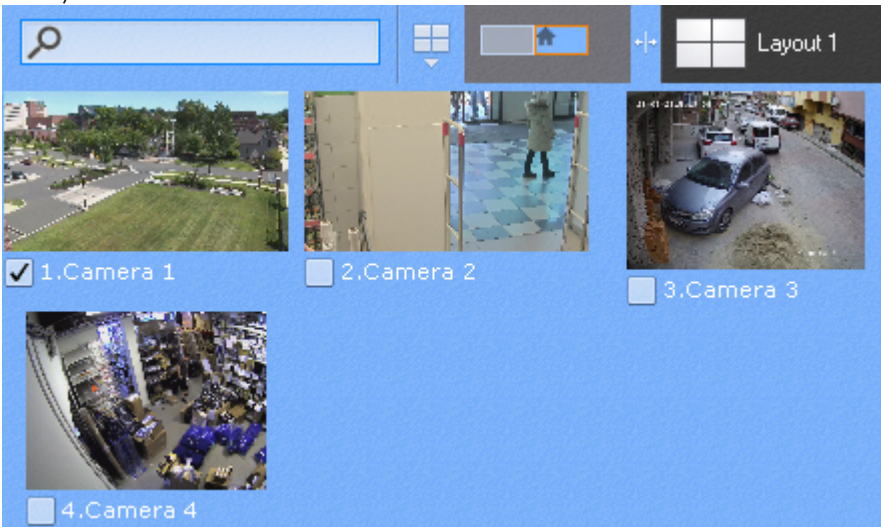

To check all cameras within an Axxon domain, check the domain's box in the Objects Panel (see [Objects Panel](#)).

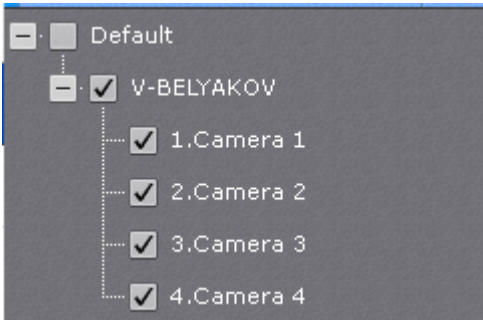

- Click the **Search** button.

8.2.7 Working with fisheye cameras

8.2.7.1 Viewing modes for video from fisheye cameras

Axxon Next allows viewing the video stream and video archive from fisheye cameras, dewarping the video image into one of the following formats:

- 360° panorama.
- Regional view.
- 180° panorama (for video camera with an Immersion lens).

8.2.7.1.1 Selecting viewing mode for videos from a fisheye camera

By default, fisheye camera video viewing mode setting is taken from device settings (see [Configuring fisheye cameras](#)), or from layout settings (see [Selecting default functions for viewing tiles](#)).

To change the viewing mode, do the following:

- Open the camera's context menu.

2. Select **Change panomorph view type to PTZ** or **Change panomorph view type to Perimeter**.

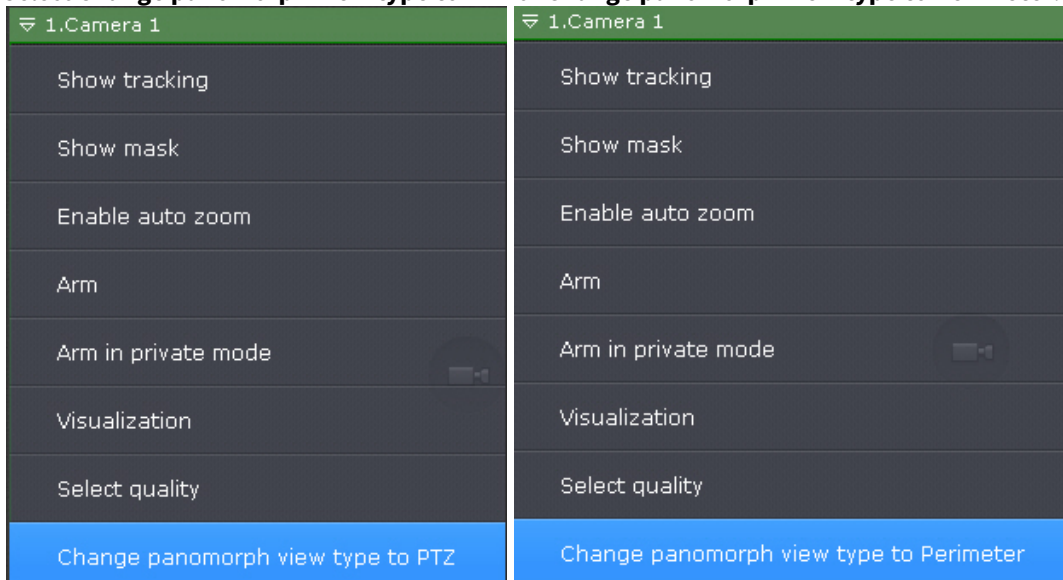

Note

This setting is not preserved if you switch to another layout.

8.2.7.1.2 360 degree Panorama and Regional view (virtual PTZ)

By default, video from fisheye cameras is displayed in viewing tiles as a 360° panorama.

Note

This display format is only available in Live Video and Archive Video modes



When digital zoom is applied to video (see [Digitally Zooming Video Images](#)) by one notch or more, regional viewing begins.

The following actions are available when viewing video in this format:

1. Point & Click functionality (see [Control using Point&Click](#)).
2. Change the angle of view of the fisheye camera, by left-clicking in the viewing tile.



In both viewing modes, all standard video surveillance functions are available for the fisheye camera.

When using a dual lens fisheye camera, the default viewing mode is set to two 180° views.



When you zoom in one of the images, both views will be merged into a single panoramic view.



8.2.7.1.3 180 degree Panorama

This viewing mode is available for:

- cameras with Immervision lenses;
- dual lens fisheye cameras.

Note

If the video camera is wall-mounted, the angle of view cannot be configured (see [Configuring fisheye cameras](#)).

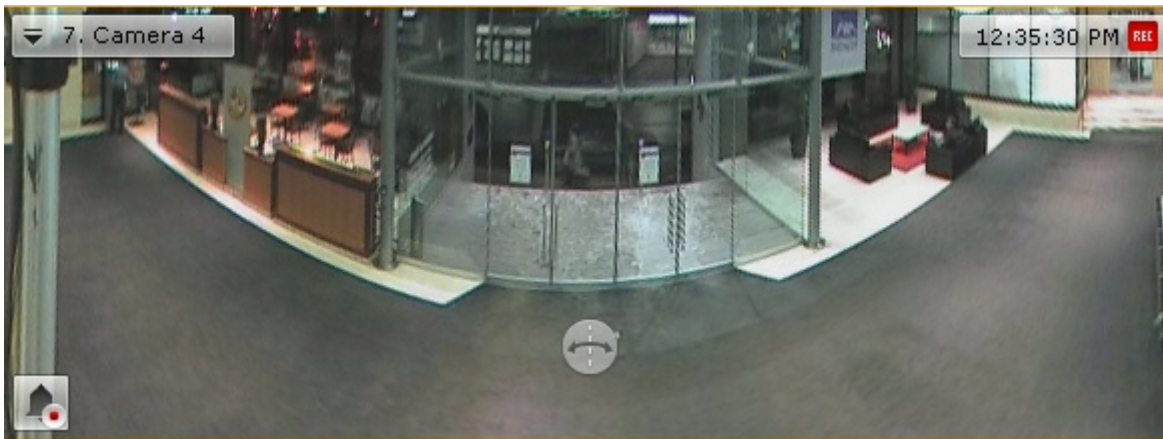

To set the viewing angle, click and hold the  button while moving the cursor to the left or right.

Point&Click (see [Control using Point&Click](#)) and all standard video viewing functions are available when viewing video in this format.

8.2.7.2 Fisheye cameras on an interactive map

8.2.7.2.1 Viewing video and controlling a fisheye camera from the map

If a fisheye camera is ceiling-mounted (this position is selected in the video camera settings, see [Configuring fisheye cameras](#)) and a 360° field of view is specified for it on the map, the video from the camera is displayed on the map in real time.

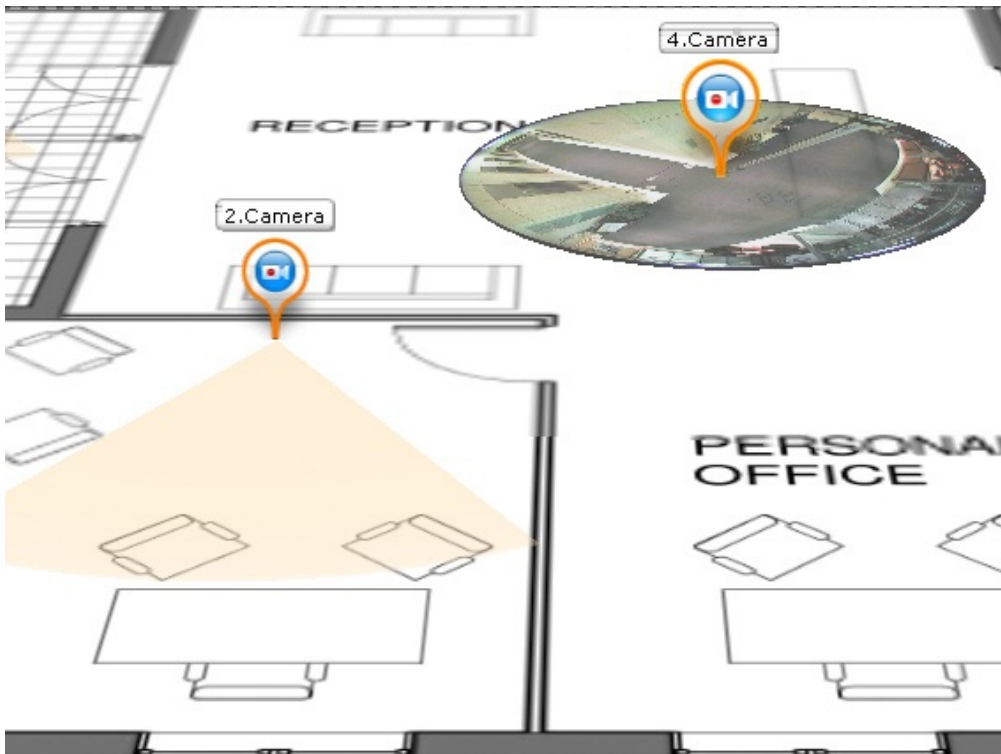

To refocus the angle of view of a fisheye camera so that a chosen point in the viewing tile becomes the center of the frame, left-click that point (this is the Point & Click function, see [Changing the camera lens focus \(Point&Click\)](#)).

Note

If the viewing tile for the fisheye camera is inactive when it is clicked, the first click on the video on the map activates the viewing tile. The second click activates the Point & Click function

8.2.7.2.2 Fisheye cameras in immersive mode

In immersive mode (see [Immersive mode](#)), the video from a fisheye camera is displayed on the entirety of the video surveillance screen, above the map display, as virtual PTZ (see [Viewing modes for video from fisheye cameras](#)).



In immersive mode, only the following video surveillance functions are available for fisheye cameras.

1. Digital zoom via mouse scrolling (see [Enlarging a video image using the mouse scroll wheel](#)).
2. Point & Click functionality (see [Changing the camera lens focus \(Point&Click\)](#)).
3. To change the angle of view of a fisheye camera, move the mouse around the video image while holding down the left mouse button.

To exit immersive mode, click the  button.

8.2.8 Facial recognition and search

Face recognition events are registered in the System Log (see [The System Log](#)).

These events can as well be displayed on the Events Board (see [Working with Events Boards](#)) or Dialog Board (see [Working with Dialog Board](#)).

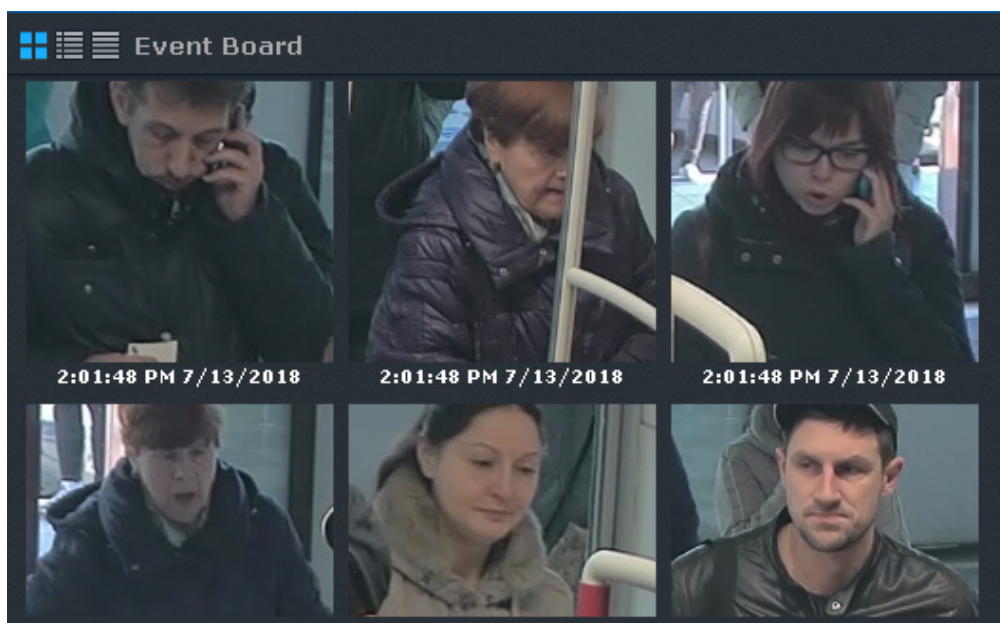

If you activate the age and gender information collection, its results will be displayed on the panel and saved into the System Log (see [Configure Facial Recognition](#)).

Event Board		
11:14:09	15.10.2018	Camera "4.7.2 Camera", Detection "Face recognition" triggered. Age - 17, Gender - Female.
11:14:08	15.10.2018	Camera "4.7.2 Camera", Detection "Face recognition" triggered. Age - 20, Gender - Male.
11:14:08	15.10.2018	Camera "4.7.2 Camera", Detection "Face recognition" triggered. Age - 32, Gender - Female.
11:14:07	15.10.2018	Camera "4.7.2 Camera", Detection "Face recognition" triggered. Age - 24, Gender - Female.
11:14:07	15.10.2018	Camera "4.7.2 Camera", Detection "Face recognition" triggered. Age - 28, Gender - Male.
11:14:06	15.10.2018	Camera "4.7.2 Camera", Detection "Face recognition" triggered. Age - 48, Gender - Male.
11:14:01	15.10.2018	Camera "4.7.2 Camera", Detection "Face recognition" triggered. Age - 44, Gender - Female.
11:13:35	15.10.2018	Camera "4.7.2 Camera", Detection "Face recognition" triggered. Age - 67, Gender - Male.
11:13:26	15.10.2018	Camera "4.7.2 Camera", Detection "Face recognition" triggered. Age - 45, Gender - Male.
11:13:23	15.10.2018	Camera "4.7.2 Camera", Detection "Face recognition" triggered. Age - 45, Gender - Female.
11:13:23	15.10.2018	Camera "4.7.2 Camera", Detection "Face recognition" triggered. Age - 65, Gender - Male.
11:13:21	15.10.2018	Camera "4.7.2 Camera", Detection "Face recognition" triggered. Age - 41, Gender - Male.

If the Camera window is linked to the Event Board (see [Linking cells](#)), you can double click on an event to start the Video Footage search for sequences containing the recognized face.

If you have created any lists of faces, configured an alarm on facial recognition, and linked the Camera window to the dialog board, you will have the following information on screen upon recognition a person that belongs to the list:

1. Reference photo from the List of Faces.
2. Close up shots of faces captured in the scene.
3. Additional information about the person, and similarity percentage between the recognized and reference photos.

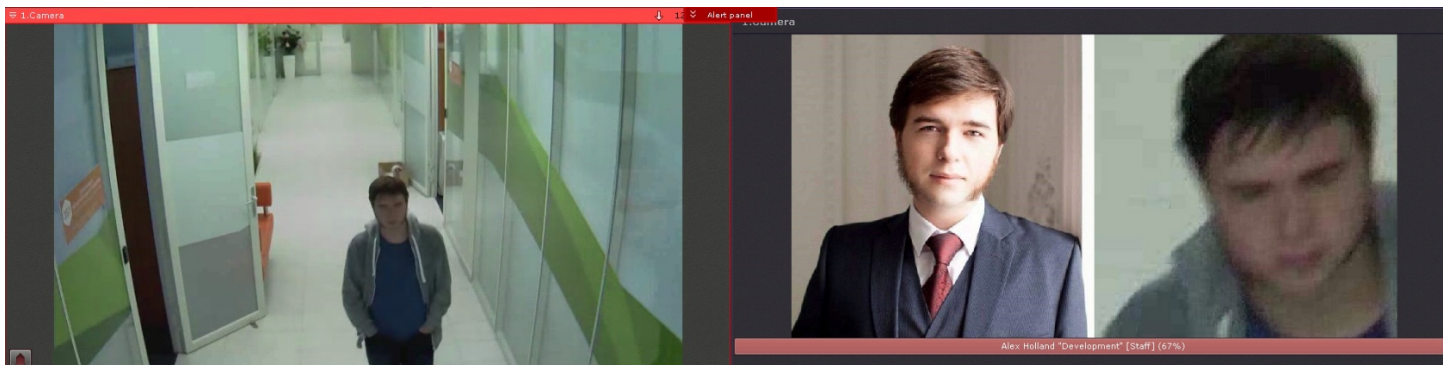

If the Dialog Board has a portrait orientation, its lower part will display the alarm video.

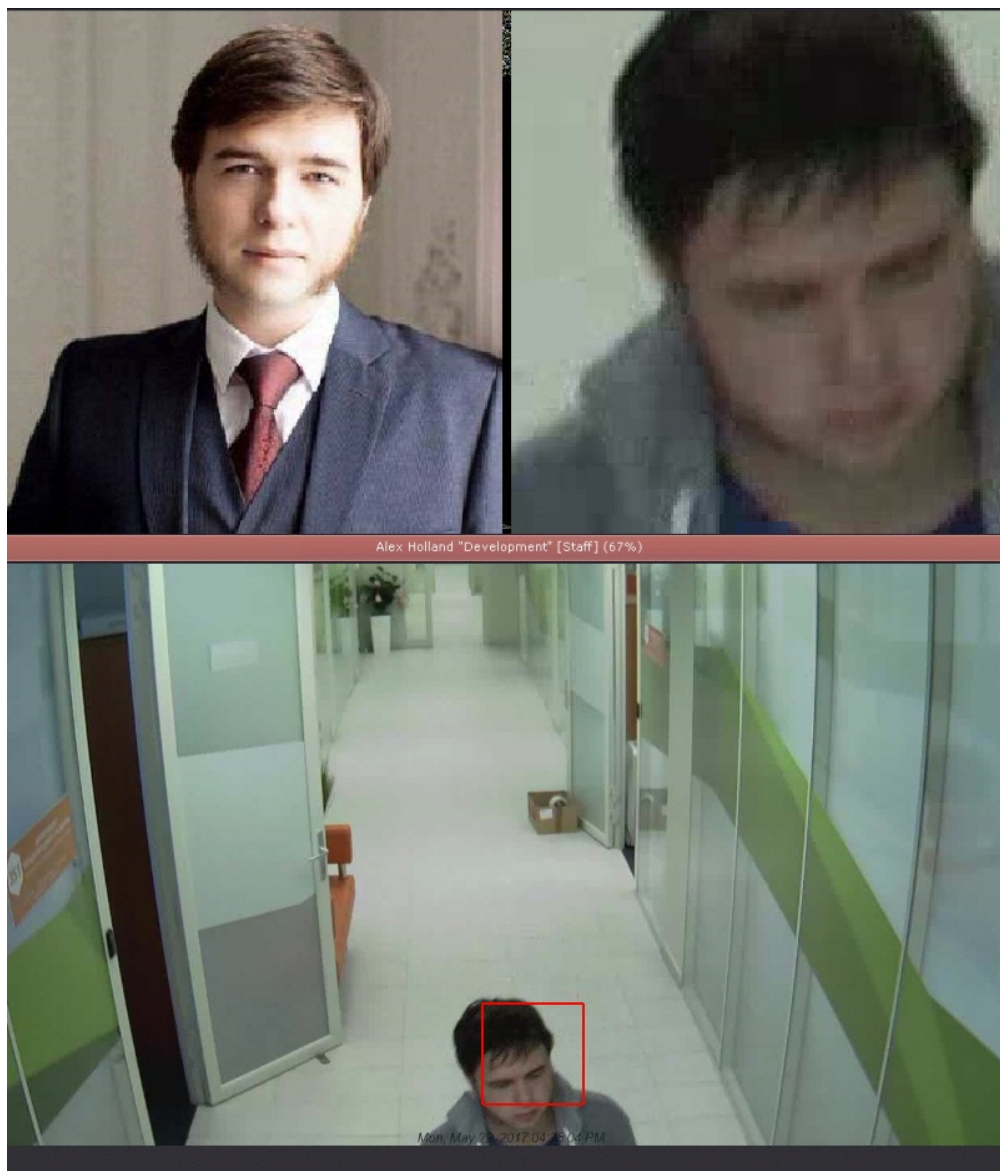

The Alarm notification panel will also include:

1. reference photo,
2. thumbnail preview of the source recognition video,
3. name of the list of faces,
4. similarity percentage.

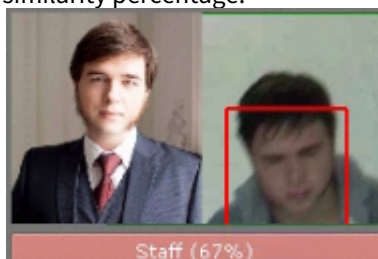

You can search FR events in recorded video from one (see [Face search](#)) or multiple cameras (see [Simultaneous search in an archive of several video cameras](#)).

You can set the system to mask recognized faces from viewing (see [Masking faces](#)).



8.2.9 Vehicle number plate recognition and search

VMS logs every ANPR number (see [The System Log](#)).

Attention!

Depending on detection tool settings, a delay may occur between the number recognition and the registration of the corresponding event (see [Configuring License plate recognition \(VT\)](#), [Configuring License plate recognition \(IV\)](#)).

The event is time-stamped with the time of recognition, not registration.

For example, if a car passes the camera at 12:05:00, and the detection tool is set to a 10 sec timeout, the event will be registered at 12:05:10 and the event data will include 12:05:00 as the time of recognition.

Attention!

The standard license provides a more than 30-sec delay between the number recognition and the corresponding event (see [Configuring License plate recognition \(VT\)](#)).

All relevant events can be displayed on the Events Board (see [Working with Events Boards](#)) or Dialog Board (see [Working with Dialog Board](#)).

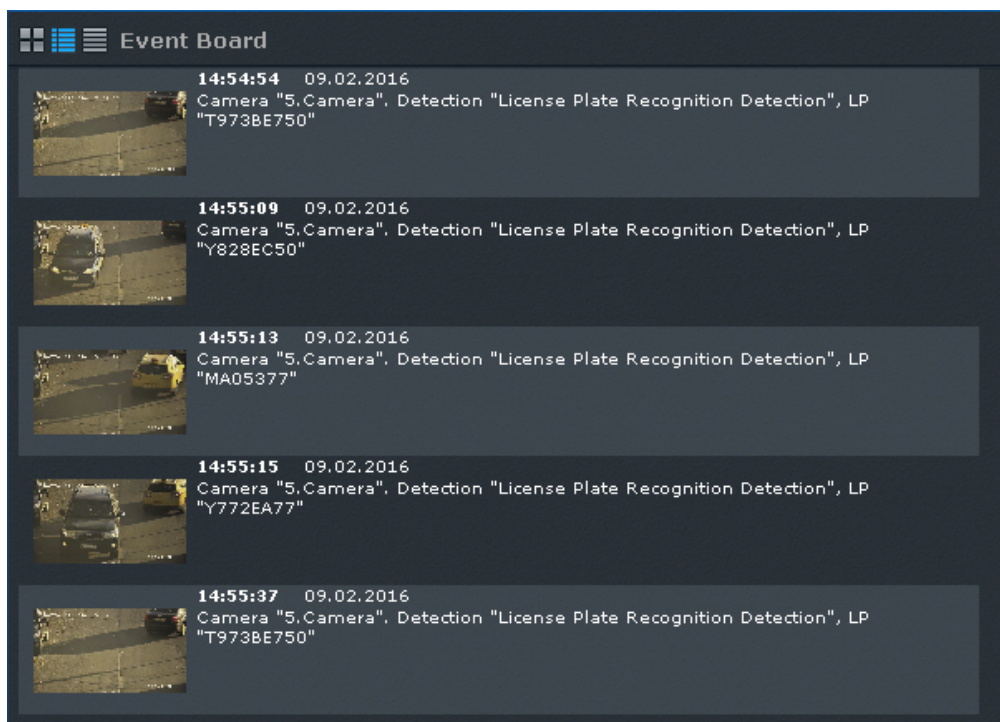

If you have created any LP Lists in your system, you can program automatic responses (e.g. alarm triggering) to LP recognition events related to list's entries (see [Configuring real-time vehicle license plate recognition](#)).

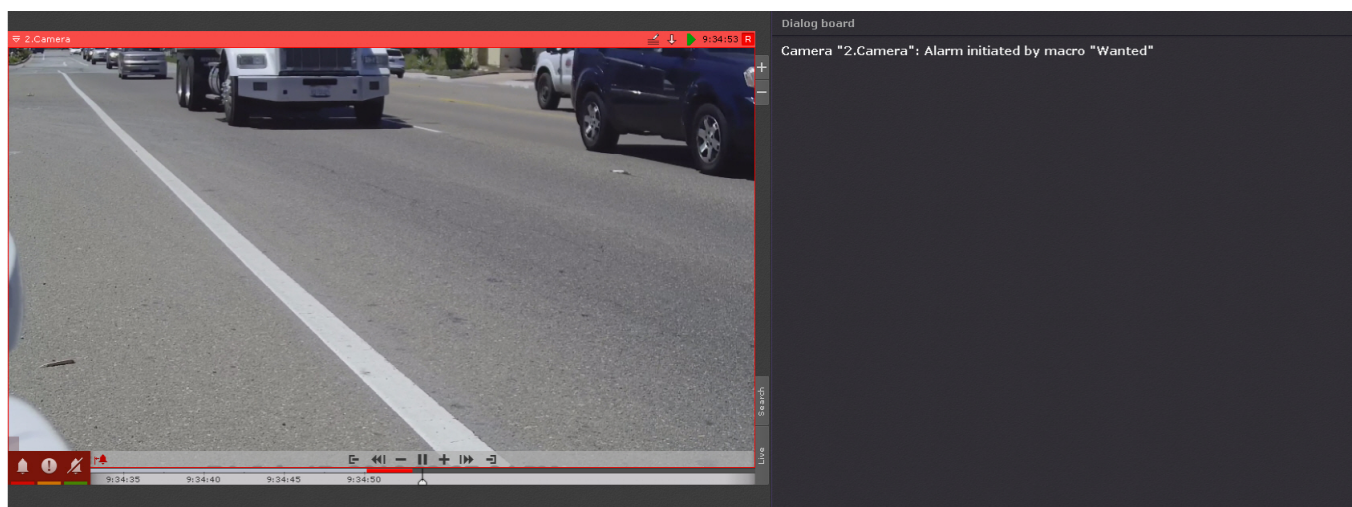

8.2.10 Temperature screening

In Axxon Next, only two methods of temperature screening are available:

1. With the use of Mobotix M16 TR cameras. In this case, temperature values are displayed next to each recognized face's bounding box (see [Face Detection and Temperature Control with Mobotix M16 TR cameras](#)).

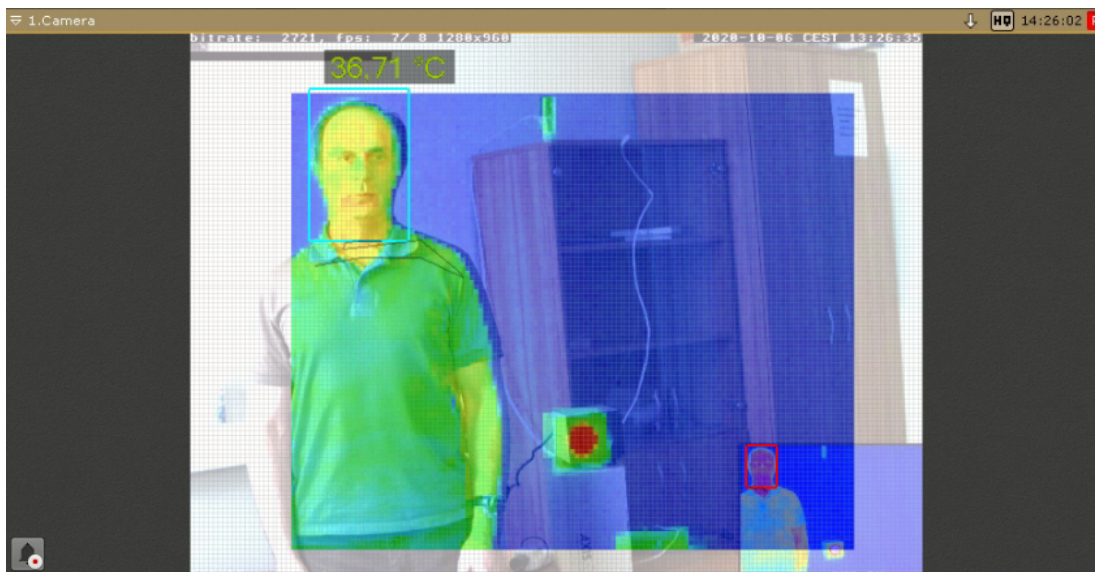

Each face recognition event contains thermal measurement data which can be displayed on the Events Board (see [Working with Events Boards](#)).

2. With the use of built-in detection tools of selected camera models (see [Embedded Detection Tools](#)). Some cameras are capable to display a bounding box over the facial image along with corresponding temperature readings. If this option is available, it can be activated via the web interface of a particular camera.

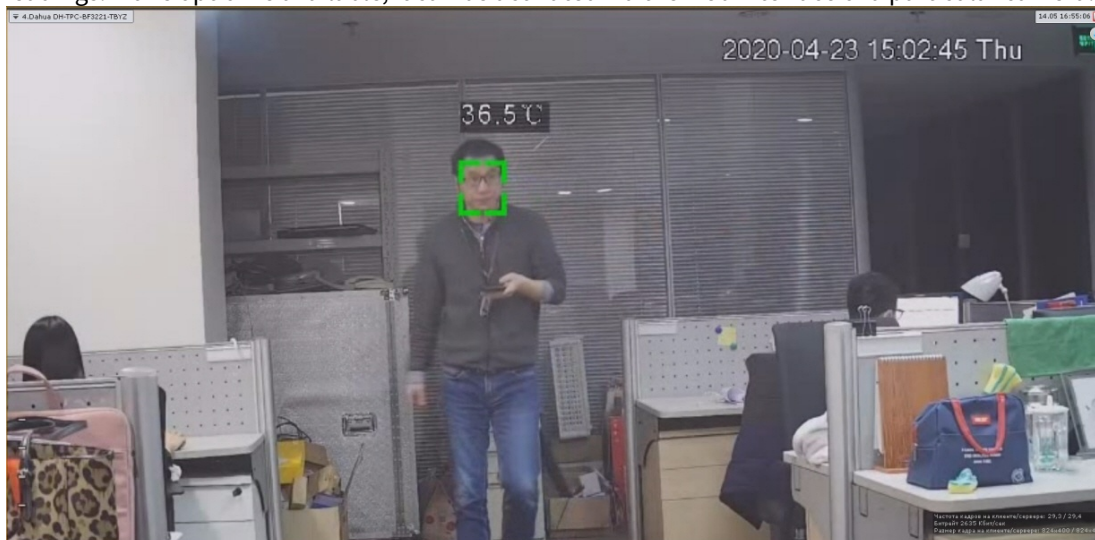

8.3 Working with information boards

8.3.1 Resizing information boards

You can resize information boards in the same way as viewing tiles (see [Scaling the Viewing Tile](#)).

Note

When the Counter Board is enlarged, the graph is enlarged as well, displaying data for a broader range of time. When the size of the Counter Board is reduced, the opposite occurs.

In both cases, the right-hand border of the graph is constant.

If an information board tile is linked to a viewing tile, at the first enlargement step (to 50%), the viewing tile and information board tile are displayed together and occupy all of the screen on one side.

Note

In this case, the first step takes into account the total size of the related cells: the related cells must be less than 50% of both sides of the layout

8.3.2 Hiding information boards

Operators can hide information boards in a layout, if this is allowed in the settings.

To hide an information board, in its upper-right corner, click the  button.

Note

If configured, Dialog Board hides after you click a **Response Button** (see [Configure the Dialog Board](#)).

If all cells in the layout have the same size, the space freed up after hiding an information board is allocated to the neighboring cells. Horizontal neighbors have priority over vertical ones.

If free space cannot be distributed horizontally, it is distributed between the vertical neighbors.

In more complicated cases (when cell sizes are different), an attempt is made to distribute the free space between horizontal neighboring cells. If this is not possible, free space is distributed between vertical neighboring cells. If even this second attempt is unsuccessful due to the layout configuration, the space remains empty.

Hidden information boards are displayed in two cases:

1. After switching to another layout and back to the original one
2. When an event occurs that requires the operator's attention A description of such events for each type of information board is given in the following table.

Types of information boards	Events that trigger board display
Dialog and Events	An event matching the board filtering settings occurs
Health	Server condition worsens
Counter	New events occur

8.3.3 Automatically switching to layouts with information boards

Automatic switching to a layout with an information board is possible for Events Board, Health Board and Dialog Board (if it is set up to Automated Responses to Events). This option is available when configuring boards of these types.

Automatic switching to a layout with Events Board or Dialog Board occurs when all of the following conditions are met:

1. The current layout does not contain Event/ Dialog Board.
2. An event matching the board filtering settings has occurred in the system.

Automatic switching to a layout with a Health Board occurs when the following conditions are met:

1. The current layout does not contain a Health Board.
2. The status of a monitored server or camera worsens.

The layout with the smallest number of cells is chosen for display. If there are multiple layouts with identical numbers of cells, the layout that comes first in the alphabet is chosen.

8.3.4 Working with Events Boards

8.3.4.1 Options for displaying information on Events Boards

Events Boards display information about selected system events. Configuration of the events to display is performed in the corresponding [section](#).

Events on the board can be displayed in three ways, chosen via the buttons in the upper-left corner of the board:

1. First frame of events and their time

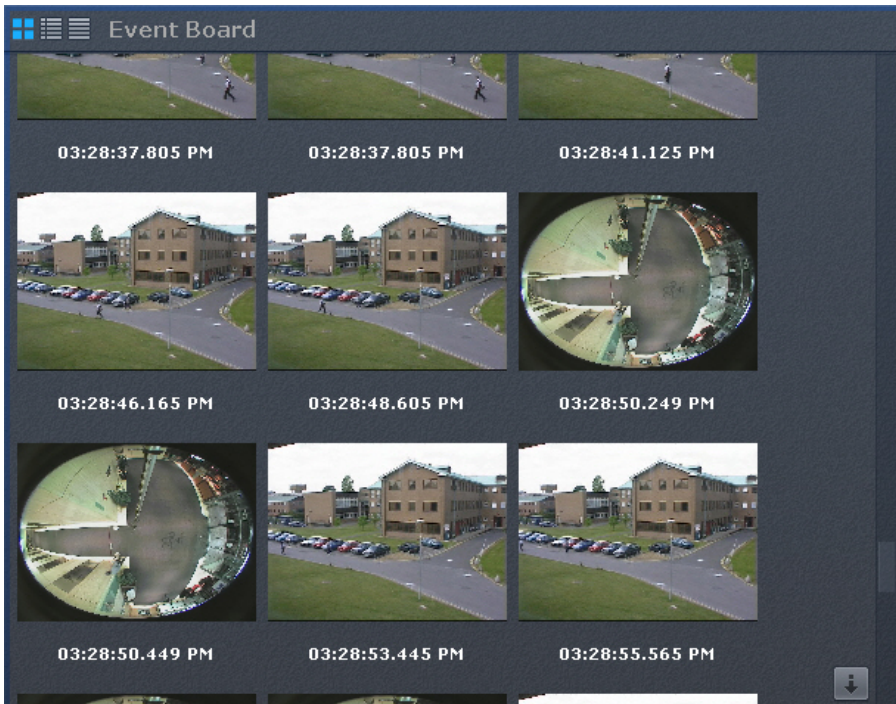

Note

The frame is not displayed when there is no recording in the archive.

2. First frame of events and text



3. Text only



When a layout is switched to, by default the Events Board is displayed as configured in the settings.

At the top of the list are the most recent events. If you are at the end of the list, you can use the  button in the panel's top-right corner to go to the most recent events. New events are highlighted for 4 seconds. The panel may include up to 100 events. If the number of events exceeds the maximum permitted value, the newer events will be displayed in place of older ones.

You can also access the events panel on the right side of the screen (see [Viewing selected camera's detection tool triggering events](#)). In this case, it includes only detection events for a selected camera.

8.3.4.2 Switching a camera linked to an Events Board to the archives

If an Events Board is linked with a camera, clicking an event will switch the camera to Archive mode at the point in time corresponding to the event.

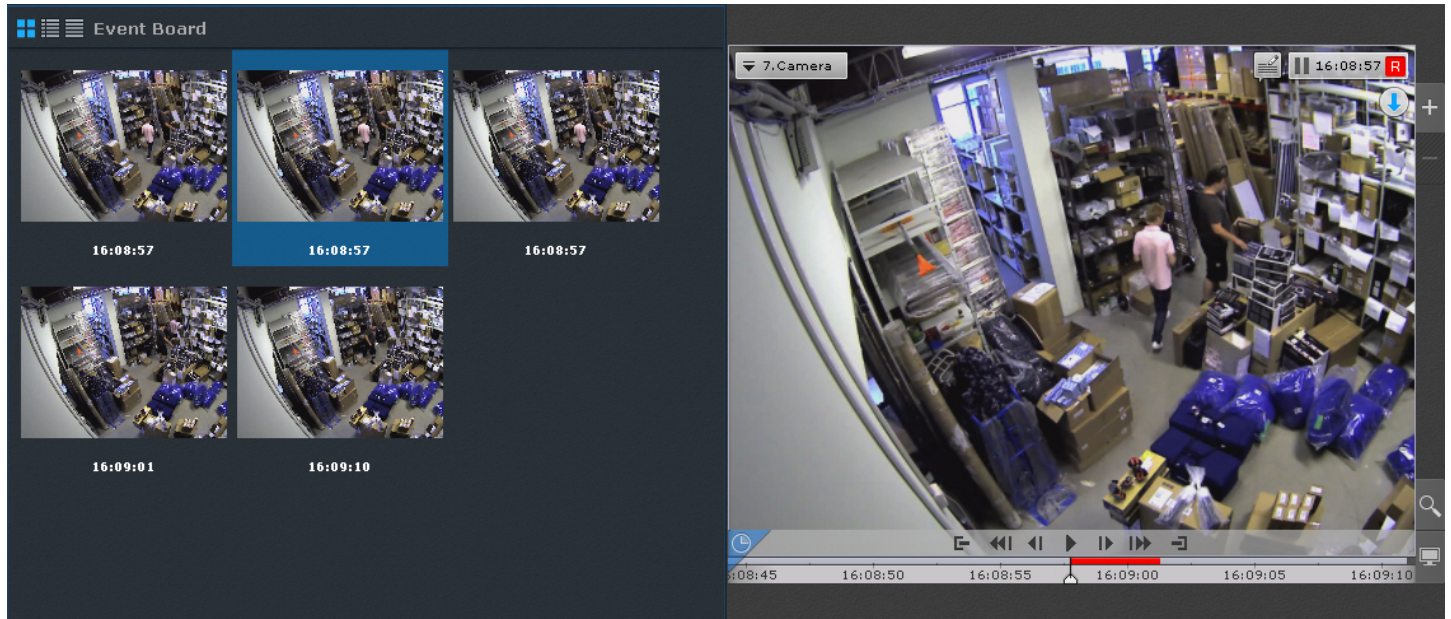

Note

If there is no archive for a camera when an alarm occurs, the archive is positioned at the closest recorded archive entry.

Note

If an Events Board is linked to several cameras, all cameras transition to Archive mode.

8.3.5 Working with Health Boards

Health Boards display the status of selected system servers and connected cameras.

By default, the panel displays the status of Servers.

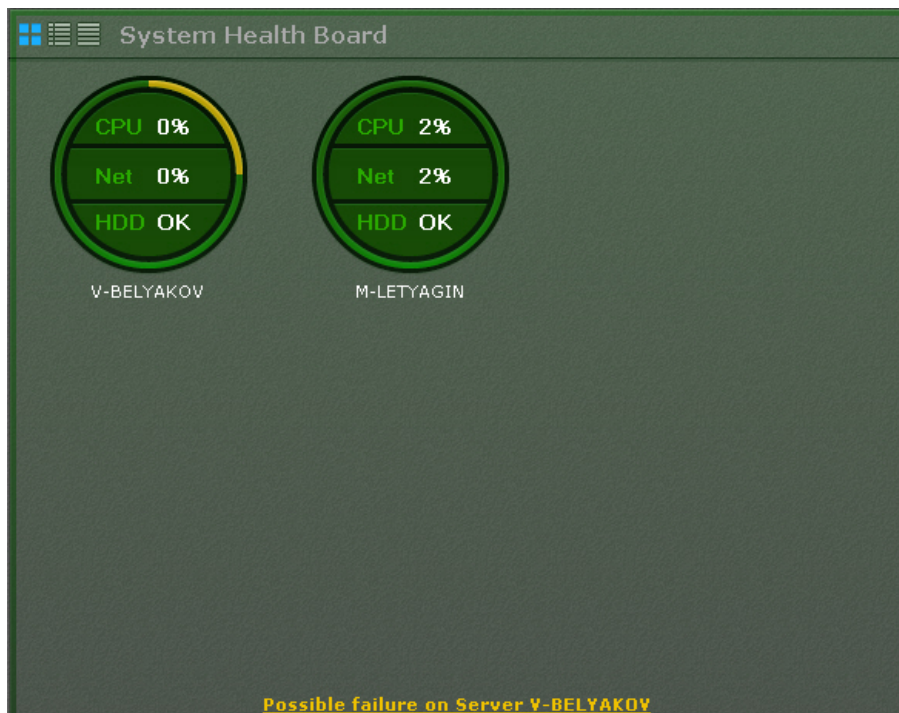

To switch to viewing the status of cameras, click the diagram for the relevant server.

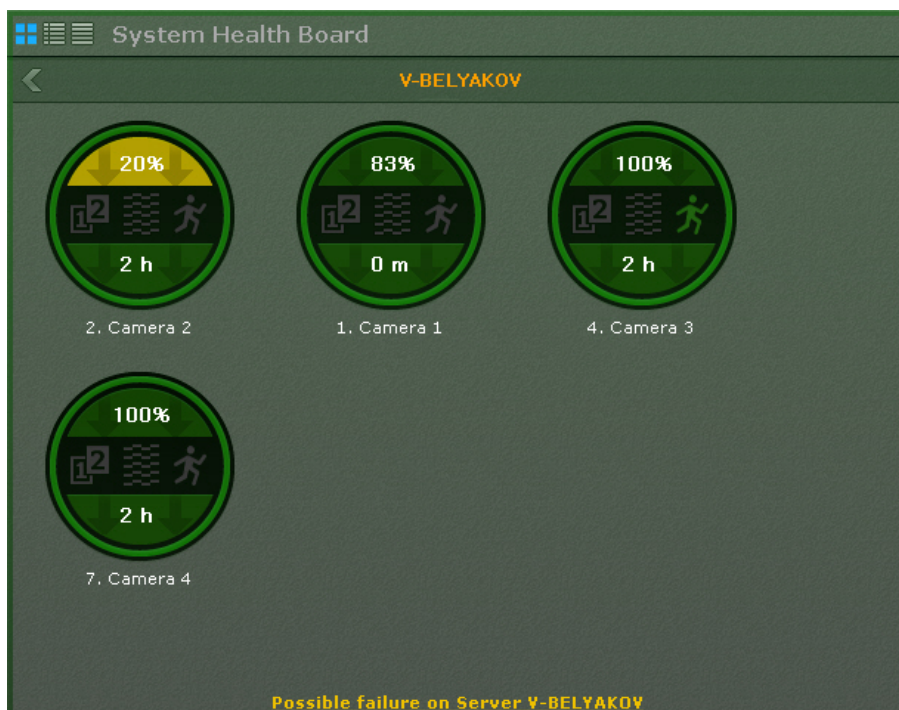

Note

In table mode, you can view server status by clicking the relevant line in the table.

To switch to a view of server status, click the  button.

8.3.5.1 Viewing server status

Information about the status of servers can be displayed in three ways, chosen via the buttons in the upper-left corner of the board:

1. as diagrams

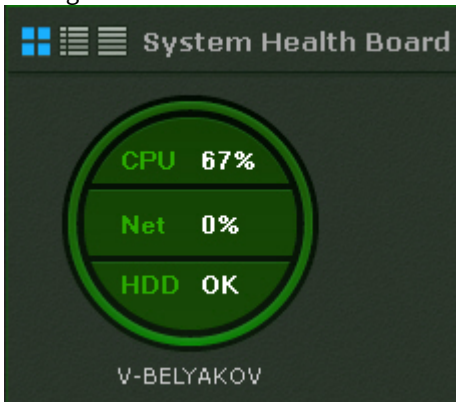

2. as diagrams with text

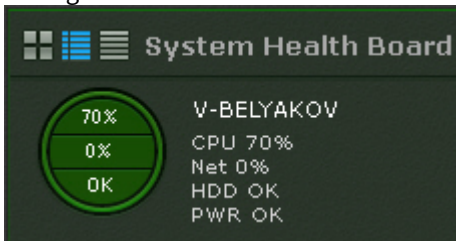

3. as a table

	CPU	Net	HDD	PWR	Replication time left	Server
↓	81%	0%	✓	✓		V-BELYAKOV

Note

Disconnected Servers are displayed at the end of the list with dimmed brightness.

Tables can be sorted by any column in any direction.

On each server the following metrics are monitored: CPU, Network usage, Disk subsystem status, Power status.

Note

The remaining time of the archive replication is also displayed in the table.

Areas of the diagram change color based on the respective status.

	CPU	Network	HDD
Red	Load >95%	Connection failure	Critical load on the disk subsystem, data loss when recording to archive over 10%
Yellow	Load from 85% to 94%	At 70% to 100% of capacity	Elevated load on the disk subsystem, data loss when recording to archive under 10%
Green	Load <85%	At less than 70% of capacity	Normal functioning of the disk subsystem (proper operation)

When you switch the server to reserve power, an  icon is added to the chart. The icon disappears when you restore the main power.

The edge of the diagram changes color based on the status of the connected cameras (see [Viewing camera status](#)).

If the entire edge is green, all cameras are in normal condition. If part of the edge is yellow or red, some cameras have borderline or critical status.

Overall server status is determined from the above parameters as follows:

1. Normal – all components and cameras are normal.
2. Borderline – possible problems with the status of at least one component or camera.
3. Critical – at least one component or camera is in critical condition.

Server information is updated every ten seconds.

If the connection to a server is lost, a corresponding icon is used to depict it.

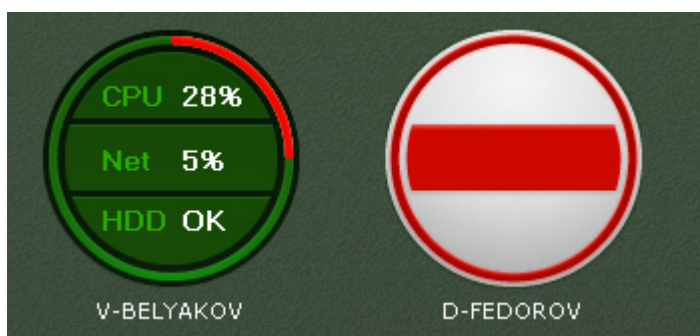

If all servers are in normal condition, the bottom of the board displays a status bar with information about the number of monitored and distressed servers.

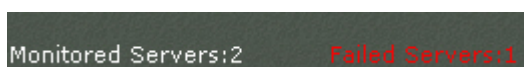

If the status of any server worsens, the status bar is replaced by a message. When the message is clicked, the server status is displayed (if the board is currently displaying camera status).

Critical state of Server V-BELIAKOV

The message then closes and the status bar again appears.

Note

If the status of several servers worsens, a message is shown for the last one.

8.3.5.2 Viewing camera status

Information about the status of cameras can be displayed in three ways, chosen via the buttons in the upper-left corner of the board:

1. as diagrams

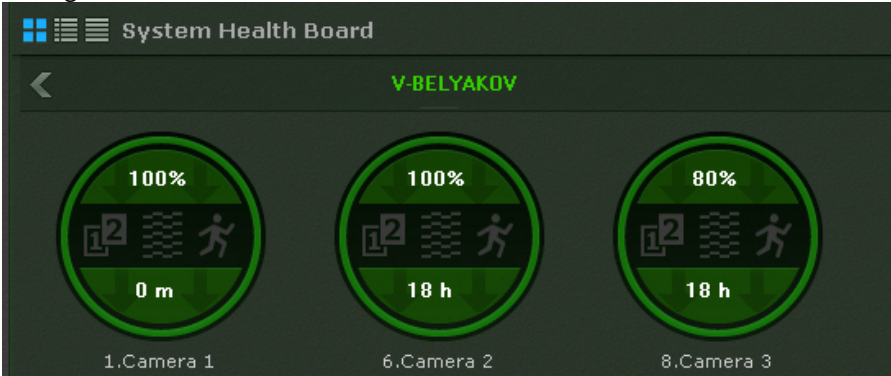

2. as diagrams with text

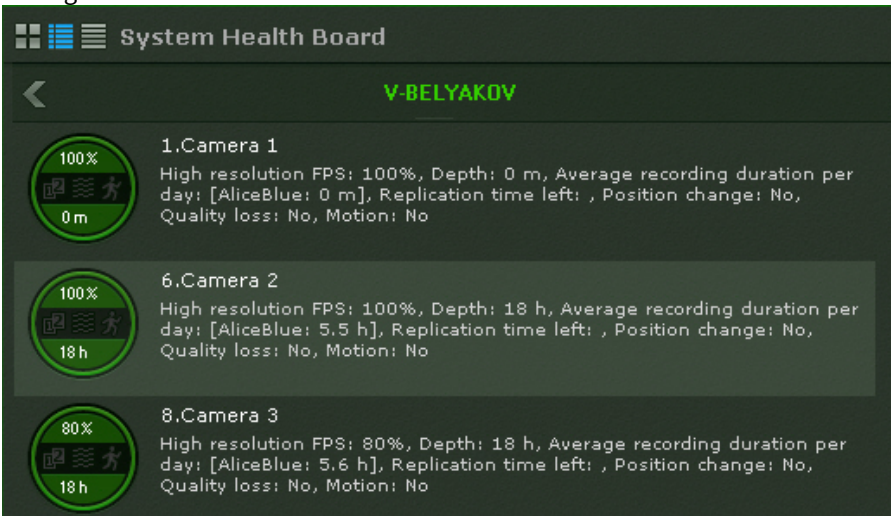

3. as a table

↓	Ca...	High...	Depth	Aver...	Repl...	Qual...	Motion	Posit...
✓	1.Cam...	100%	0 m	0 m		No	No	No
✓	6.Cam...	100%	18 h	5.5 h		No	No	No
✓	8.Cam...	80%	18 h	5.6 h		No	No	No

Note

Disconnected cameras are displayed at the end of the list with dimmed brightness.

Tables can be sorted by any column in any direction.

The following information is displayed for each camera:

1. The percentage rate of actual video fps to the camera's high definition stream fps setting (see [The Video Camera Object](#)).
2. Status of detection tools (loss of quality, position change, motion)
3. **Depth** refers to the number of hours or days from the start of the earliest video stored in any archive to the end of the most recent video (if archive recording is not configured for the camera, this section is colored gray on the diagram).
4. Average recording time, in hours per day, is the ratio of the total recording time to the age of the archive / retention time (time from the earliest stored video to now).

Note

For constant recording, this parameter value is equal to 24 hours. If the recording takes 50 percent of total time, the value is 12 hours.

5. Remaining time for replication of the archive.

The camera status is measured based on the signal from the camera and stream rate:

1. Normal – camera signal present, frame rate & to max from 70% to 100% The camera is colored green on the diagram and in the table.
2. Borderline – camera signal present, frame rate & to max from 20% to 70% The camera is colored yellow on the diagram and in the table.
3. Critical – no camera signal or frame rate & to max is less than 20% The camera is colored red on the diagram and in the table.

Information is updated every ten seconds.

If there is no signal from a camera, the appearance of the diagram changes accordingly.

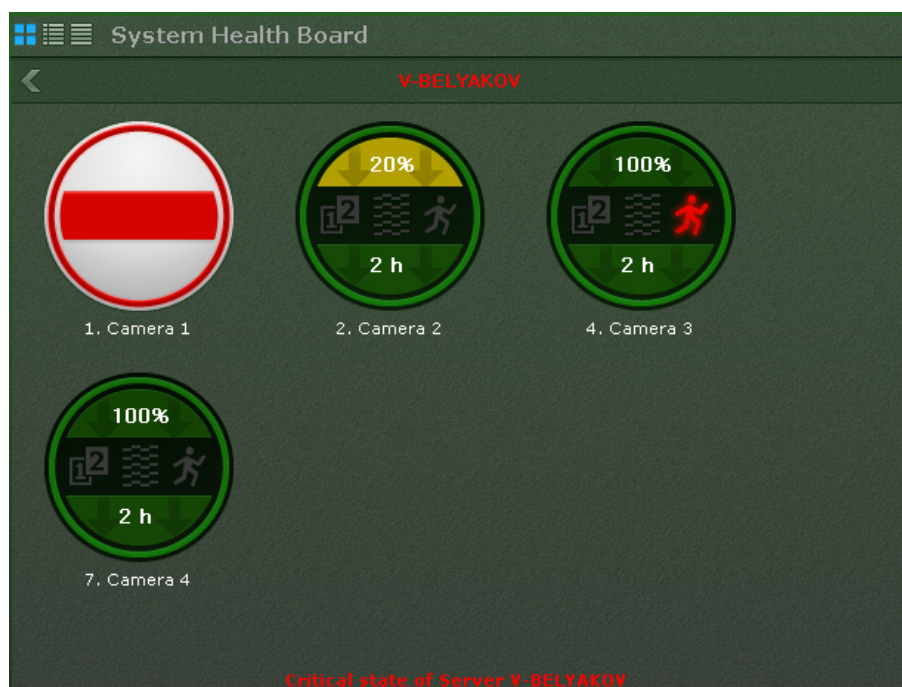

Information about detection tools is received in real time. Depending on the status of detection tools, the corresponding icons change color:

- Green – detection tool status is normal
- Red – detection tool activated
- Gray – detection tool disabled

8.3.6 Working with Statistics Boards

The Statistics Board is a graph of the number of events of a certain type for a specified timeframe. The type of events and amount of time between the points of the graph are configured in the board settings (see [Configuring a Statistics Board](#)).

The points of the graph change over time and depend on the current time and interval specified in the settings.

The points are calculated every minute/hour/day/etc. based on the selected unit of measurement (if the interval is specified in minutes, then every minute; if specified in hours, then every hour, and so forth) and is performed as follows:

1. The current time (last point on the graph) is rounded to the nearest whole unit of time (if the interval in the settings is specified in minutes, then the nearest whole minute; if specified in hours, then the nearest whole hour, and so forth).

2. This rounded time is used as the next-to-last point.
3. The formula for the other points is as follows: the adjacent point to the right, minus the interval of time specified in the settings.

For example, the interval is set to **10 minutes** on this sample graph here. The current time (**1:07:33 p.m.**) is the last point on the graph, so after rounding this to the next whole minute we get the value for the next-to-last point: **1:07:00 p.m.** Correspondingly, the points before it are **12:57:00 p.m., 12:47:00 p.m.**, etc.

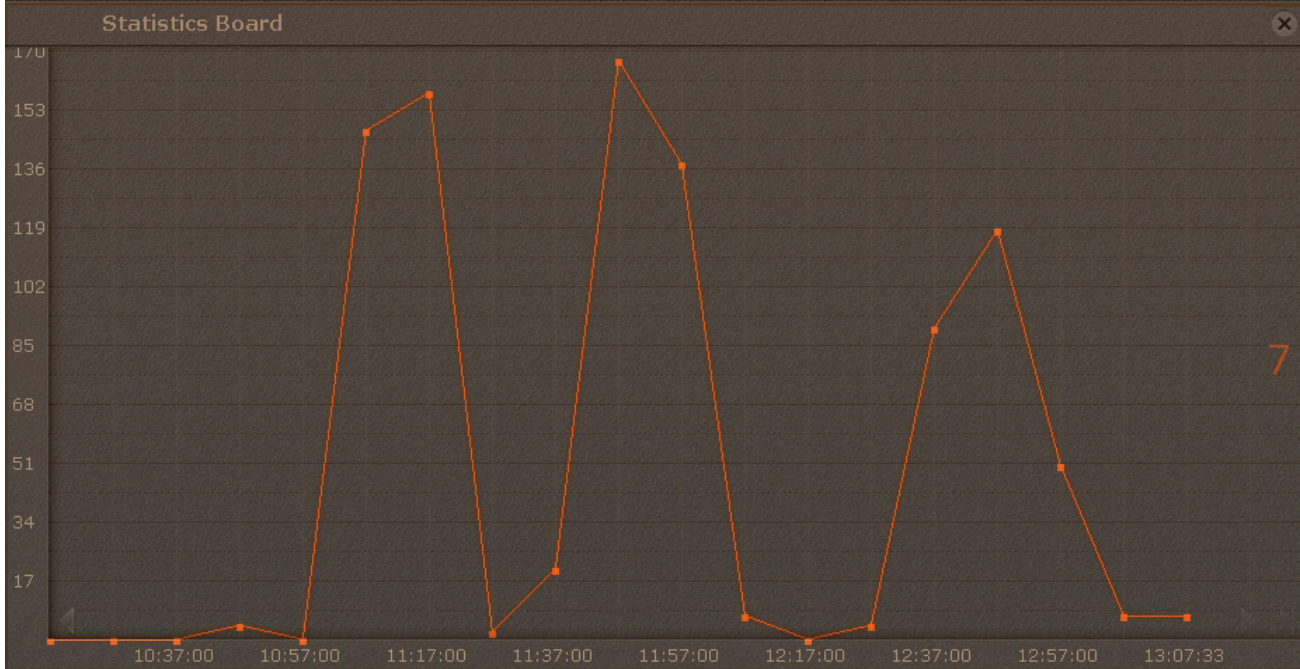



When the current time becomes **1:08:00 p.m.**, the points will be updated to **12:58:00 p.m., 12:48:00 p.m.**, etc.

The graph displays the current number of events. The number of events is recalculated every minute and does not depend on the interval chosen.

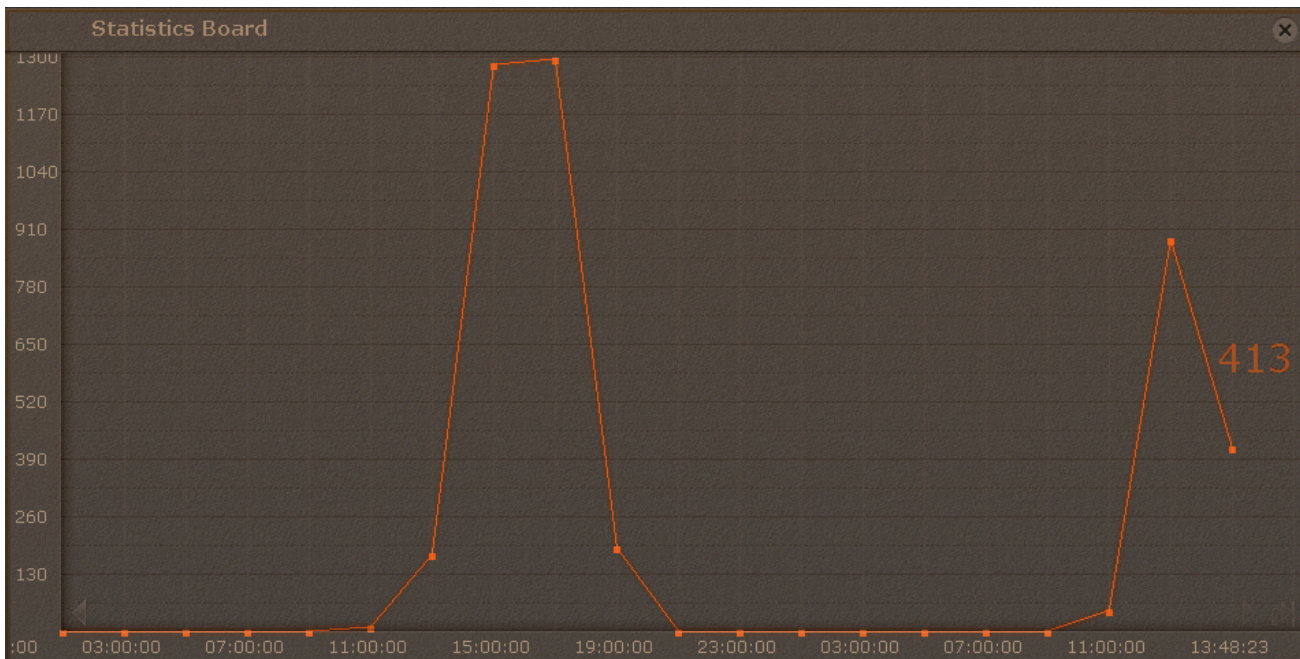
For example, for this graph with a time interval of **2 hours** and a current time of **1:48:23 p.m.**, the current number of events equals **413**, for the period from **11:48:00 a.m. to 1:48:00 p.m.**



To scroll through the graph, use the arrows  on the graph edges. To jump to the last point on the graph, click the  button.

Clicking anywhere on the graph jumps to the nearest point and the relevant value is indicated.

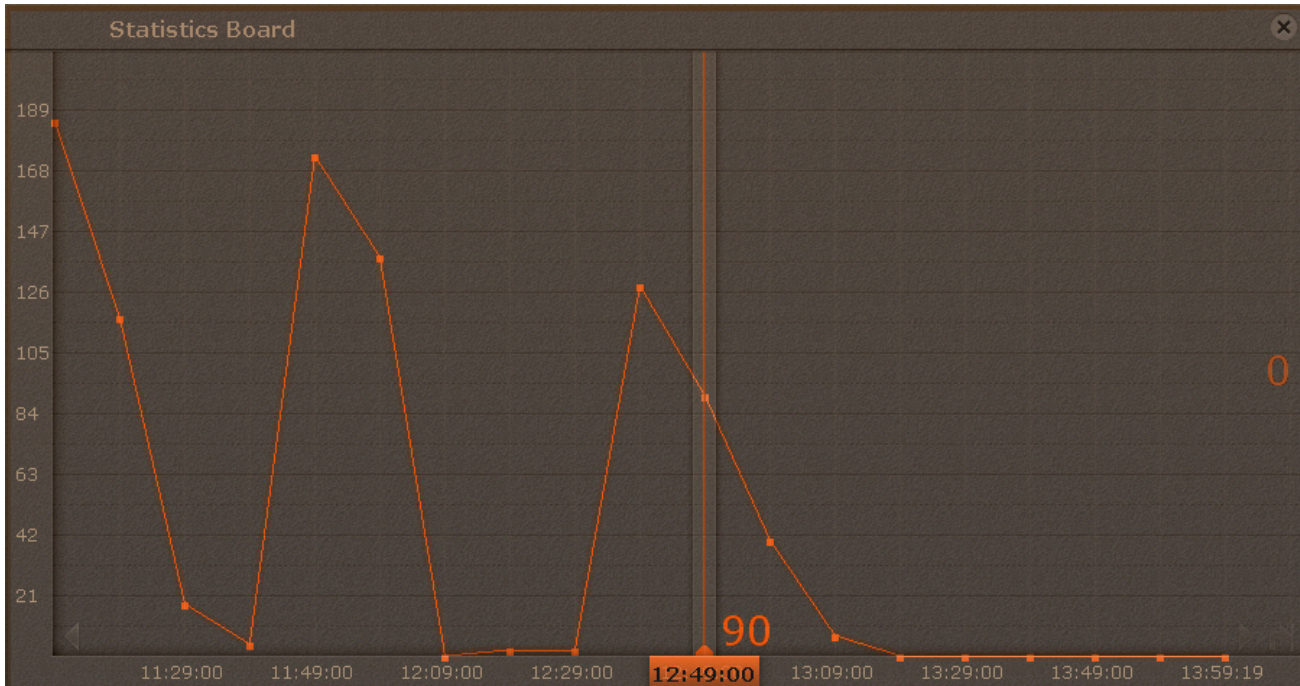

8.3.7 Working with Web Boards

Web Board allows users to view a selected web page in the camera window.

In Web Board, you can view web sites in Internet Explorer.

If the web page does not fit the board, vertical and horizontal scroll bars are displayed. In this case, the upper-left corner of the web page is displayed.



Note

If there is no network connection, no access to the requested page or if there are other problems, Web Board displays standard *Internet Explorer* browser error messages.

8.3.8 Working with Dialog Board

[Configure the Dialog Board](#)

Dialog Board works in three modes:

1. Automated Responses to Events.
2. View and Evaluate Alarm.
3. View Video (Active camera).

In Automated Responses to Events, the board shows:

1. The last-in event matching the board filtering settings (1, see [Configure the Dialog Board](#)).

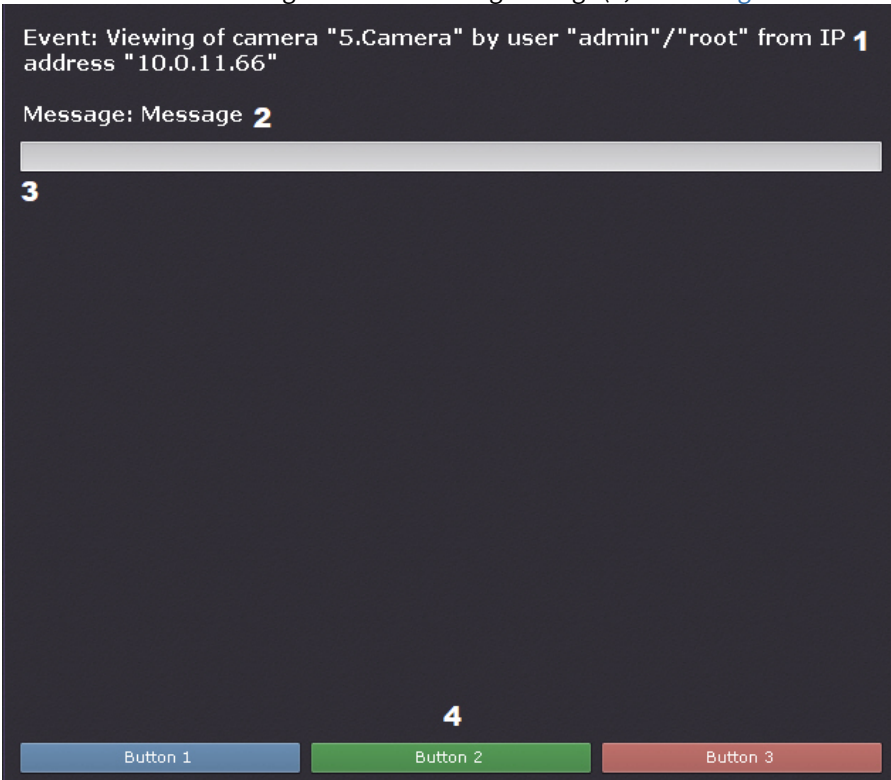

Note

All of the above mentioned elements of the board are optional. You configure the board to show them.

2. Text message as configured (2).
3. Comments filed (3). Comments input can be optional or mandatory (as configured). Comments are logged to [System Log](#), when you click a response button.
4. Response Buttons (4). If you click a response button, the macro starts, and the board auto-hides (if configured, see [Hiding information boards](#)).

If the pane has a history of events (see [Configure the Dialog Board](#)), you can use browse it with arrows in top-right corner. Event history is erased after you switch to another layout.

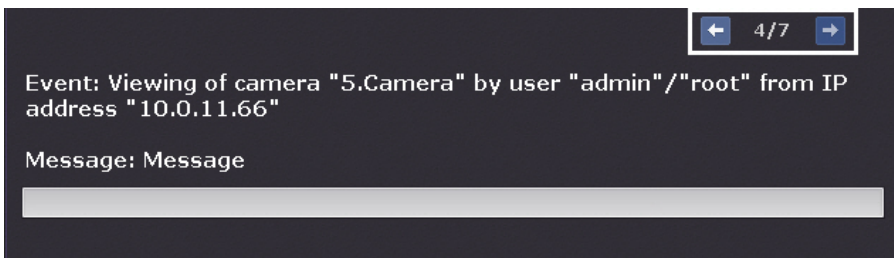

In the second mode, the panel will display an alarm event from the selected or linked camera, depending on the panel setting and the event evaluation buttons.

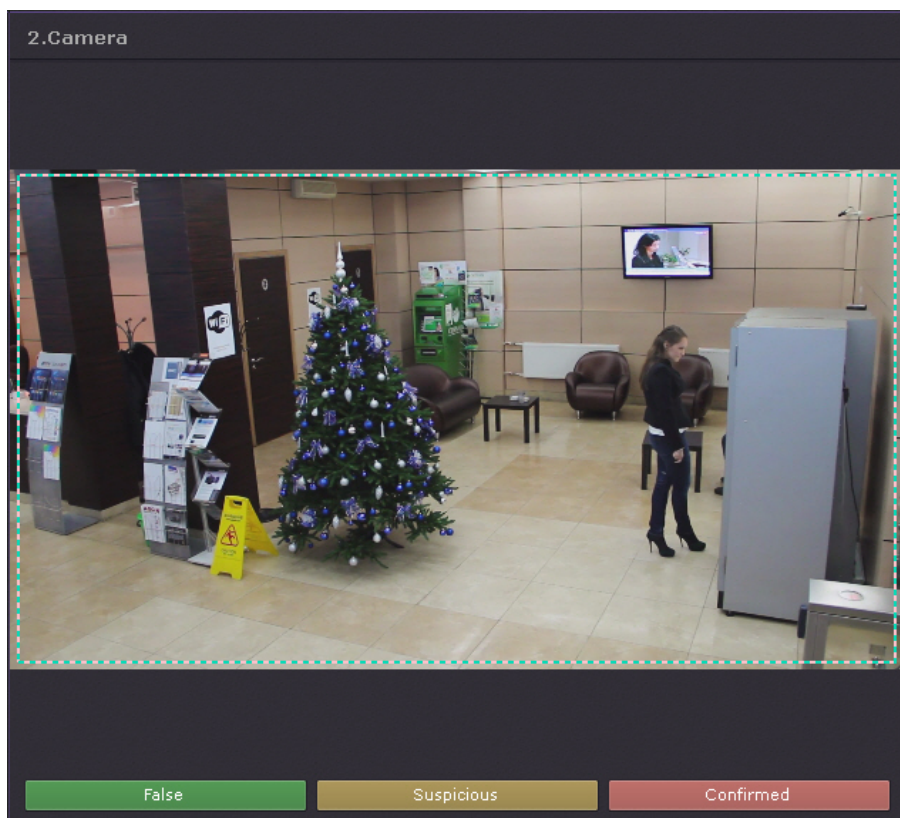

In the third mode, the panel shows video:

1. from the selected camera;
2. from the stand-by camera for the selected camera.
3. from the stand-by camera for the linked camera.

You can select a camera if you click on its tile on a layout, in the Objects panel (see [Objects Panel](#)) or on the map (see [Working with the Interactive Map](#)).

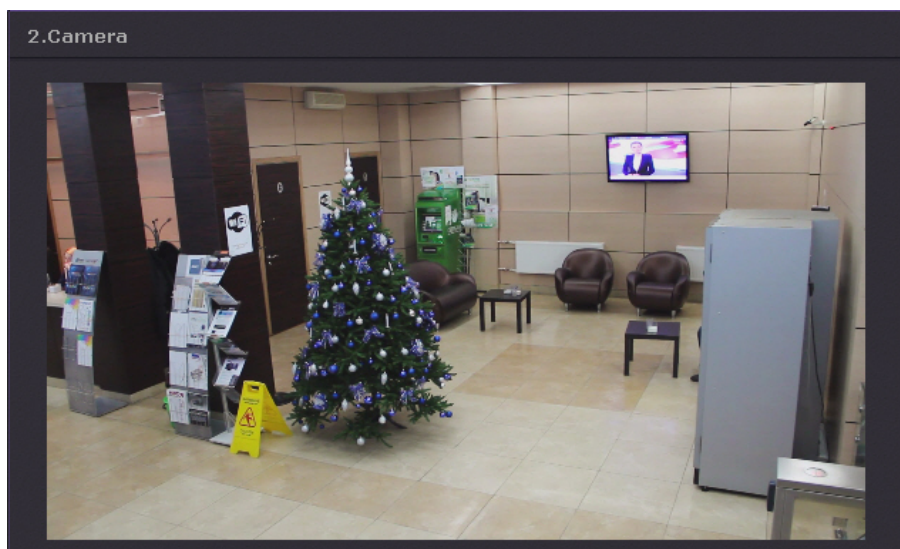

The panel can also display a selected still image.

8.4 Layouts Management

The *Axon Next* user can run the following commands here:

1. Select a layout for display on screen.
2. Start and stop slideshows of layouts. Slideshow is rotation through all available layouts according to an assigned frequency (dwell-time).
3. Create temporary layouts.

You can work with layouts done on the Layouts ribbon (see [The Layouts panel](#)).

8.4.1 Changing cameras within a layout

You can change cameras within your current layout. These changes are non-permanent and will persist until you switch to another layout.

You can change:

- any single camera;
- all cameras within the layout.

To change a single camera, drag and drop its icon from the Objects Panel (see [Objects Panel](#)) or Camera Search Panel (see [Camera Search Panel](#)) to the layout cell of your choice.

To change all cameras within the current layout, select the required number of cameras on the object panel, and drag&drop it to the layout.

Note

To select multiple cameras, use Ctrl or Shift key.

After you drag and drop a group of cameras, the layout will include all cameras from this group; when you drag and drop an Axxon domain, all cameras from this domain will be displayed.

Note

Currently disabled cameras will not be included.

8.4.2 Selection and Slideshow of Layouts

To display a layout, click it with the left mouse button.

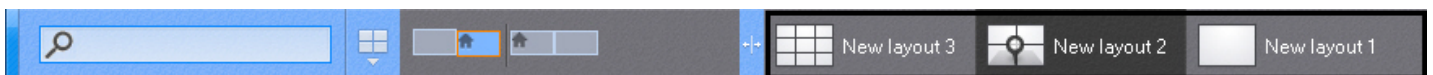

If the client is connected to multiple Axxon domains, layouts for the main Axxon domain are listed by default. To view the layouts of other Axxon domains, select the desired domain on the [camera search panel](#).

If another user has shared the layout, you will see the following icon:

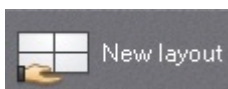

Note

If you hover the mouse cursor over such a layout, you will see the name of the user that has shared it.

To launch a slideshow, click the  button, and select **Start slideshow** in the context menu of the layout panel.

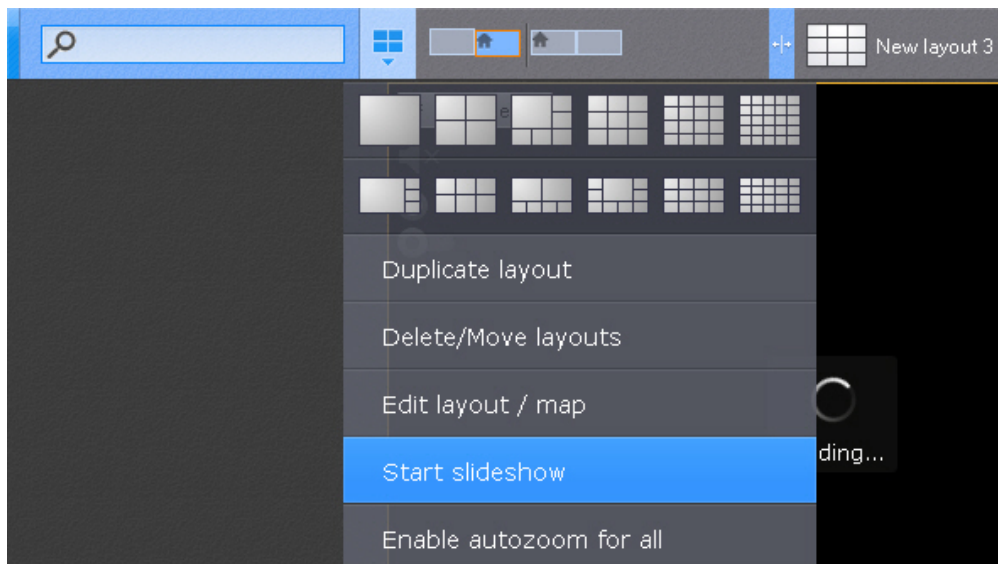

Note

If you have only one layout in VMS, you do not have **StartSlideshow** in the context menu.

This will launch a carousel of all available layouts according to the assigned dwell-time (see [Configuring Slideshow parameters](#)). To launch a user-defined slide show, select the required one from the list.

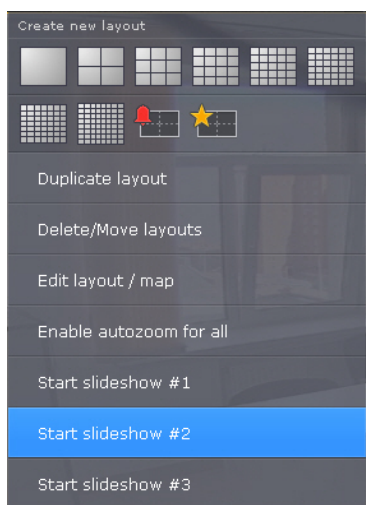

Note

To launch a slide show on a video wall (see [Monitor Management](#)), select the required monitor in the Video Wall Management Panel (see [Monitor Panel](#)).

To turn off slideshow mode, select **Stop slideshow** in the context menu of the layouts panel or left-click any viewing tile.

8.4.3 Working with Special layouts

[Configuring special layouts](#)

Alerted Cameras layout

The first 10 seconds after the alert appears in the special layout, it is highlighted.



Cameras disappear from the Alerted Cameras layout in 2 cases:

1. After the alert is classified and the next camera is on (see [Processing an Alarm](#)).
2. After the timeout expires (see [Configuring Alarm Management Mode](#)).

Note

The alarm sticks to the layout while the Alarm Management window is open and before the timeout expires. If you select a different camera without classifying the alarm, the alarm evaluation timeout resets

New alerted cameras will populate the layout as follows:

1. If there are any free cells on the layouts after you have classified or missed the alert, the first free cell is taken.
2. If there are no free cells on the layout, the new alerted cameras takes the next free cell. If there are no free cells, the alerted camera is added to the waiting list

Selected Cameras layout

All selected cameras are displayed on this layout.

Dynamic Layout

By default, Dynamic Layout is empty. You can add cameras from the object panel (see [Objects Panel](#)) one by one or several at once (a group, all video cameras of the Server or Axxon Domains).

To do this, select the target unit on the object panel and drag&drop it to the layout. The grid of cells will be displayed on the layout while you are moving the unit.

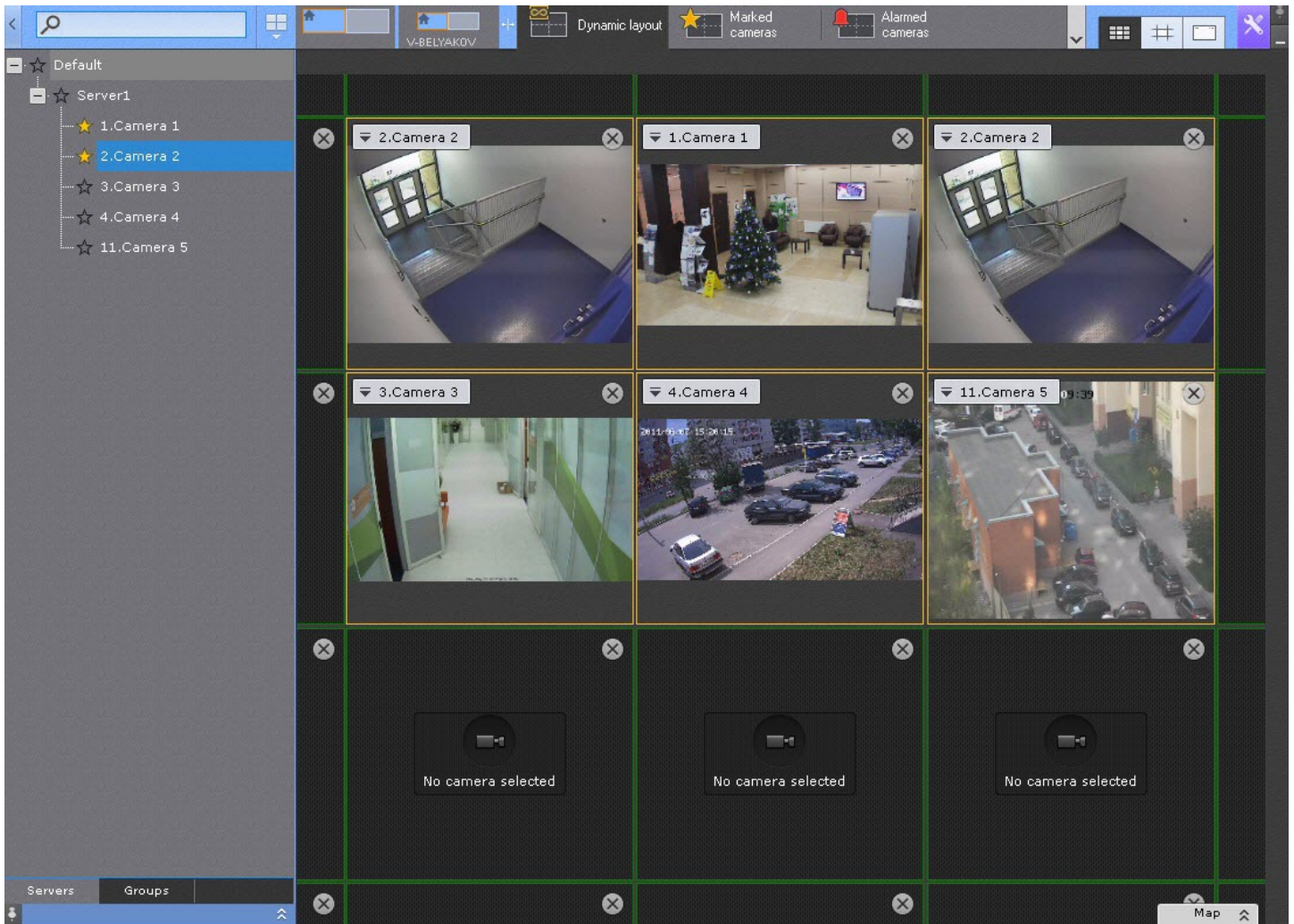

All changes to the Dynamic Layout are preserved until you exit the Client. After you launch the Client, the Dynamic Layout is always empty.

However, you can back up your Dynamic Layout at any given time (see [Layout copying](#)).

8.5 Monitor Management

8.5.1 Managing monitors on a local Client

You can display layout on any hardware monitor of a Client. To do it, follow the steps below:

1. Click anywhere on the local Client's monitor layout diagram (see the [Monitor Panel](#) section).

Note.

Client monitor management falls under user rights (see the [Creating and configuring roles](#) section).

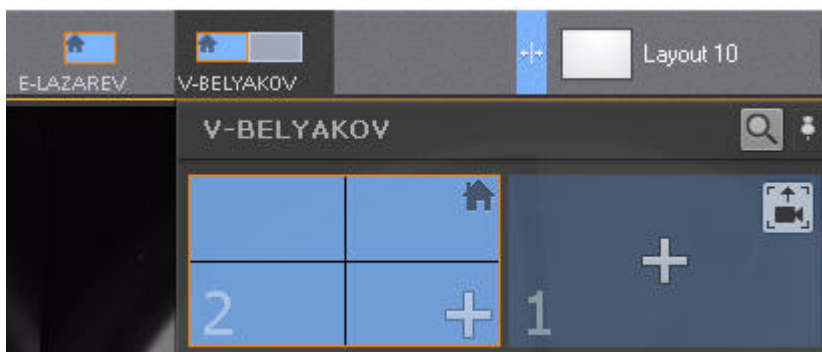

Monitors' expanded views open.



Note

Each monitor has its unique ID number. To display the ID number of a monitor, click .

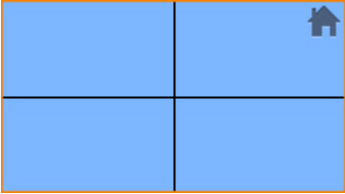
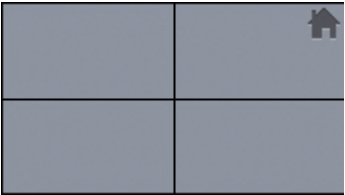
The thumbnails may appear differently, depending on the status of the monitors in Axxon Next.

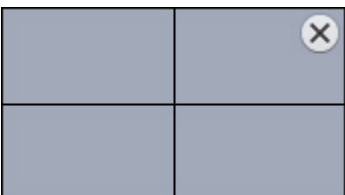
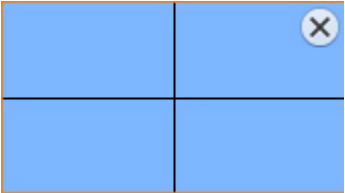
Thumbnail	Monitor status
	Active main monitor
	Inactive main monitor
	Unassigned additional monitor
	Inactive additional monitor (video wall)
	Active additional monitor (video wall)

Note.

The image of the monitors shows the currently open layout.

2. To display the layout on the monitor, you have to:
 - a. Click the **+** button on the non-distributed additional video monitor's thumbnail. The additional monitor becomes active, and the layout of the main monitor is duplicated to it.
 - b. Set up a layout on an additional monitor (see the [Configuring layouts](#) section). You can configure the layout of the additional monitor through the main monitor (the additional monitor must be active). Changes affect only the additional monitor; the layout of the main monitor is not changed.
 - c. Click the main monitor's thumbnail. The additional monitor becomes inactive, and the original layout is displayed on the main monitor. If the additional monitor becomes inactive, editing of the layout does not affect it.
3. To display a currently selected camera on the main monitor, do the following:
 - a. Click the  button on the non-distributed additional video monitor.
 - b. Selecting a camera on the primary monitor makes its video feed visible on the additional monitor.

The additional monitors are now configured.

To edit a layout on an additional monitor, do the following:

1. Activate the additional monitor (by clicking its thumbnail).
2. Edit the layout.
3. Make the additional monitor inactive.

You can change the set of cameras to be displayed on the main or additional monitor using the Objects Panel; these changes are not saved, and the initial layout is restored after rebooting the Client. To do it, follow the steps below:

1. Open and lock the Monitor panel (see [Monitor Panel](#)).
2. Open the Objects Panel (see [Objects Panel](#)).
3. Using the Ctrl or Shift keys, select one or several cameras on the panel.
4. Left-click on any selected camera.
5. Drag the camera icon onto a desired cell on the main or additional monitor's layout diagram.
6. Release the mouse button

Another way to put a camera into a desired cell on the main or secondary monitor layout diagram is to capture the camera's icon on the interactive Map (see [Working with the Interactive Map](#)).

You can close main and additional monitor views separately. To close an additional monitor in *Axxon Next*, click the  button on its thumbnail.

8.5.2 Managing monitors on remote Clients within the Axxon domain

Having appropriate user rights, you can remotely manage monitors on remote Clients connected to a Server within the Axxon domain (see the [Creating and configuring roles](#) section).

The following actions are possible:

1. Add a layout to an additional monitor of a remote Client.
2. Select another layout or a camera on the additional monitor.
3. Edit a layout on the main or additional monitor.
4. Shut down the additional monitor.

To display a layout on the additional monitor of a remote Client, click anywhere on the required Client's monitor layout diagram, and select a non-distributed video monitor (see [Monitor Panel](#)).

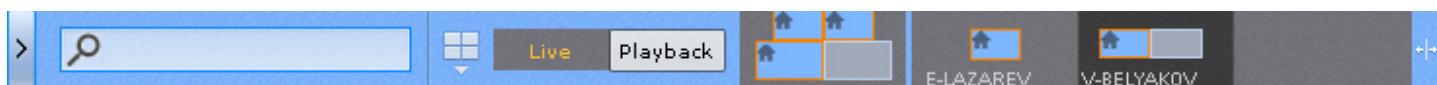

Note

You can add a layout to the additional monitor of a remote Client the same way as you do it for a local Client (see [Managing monitors on a local Client](#)).

To select another layout on a remote Client's monitor, do the following:

1. Select the desired layout on the local Client (see [Selection and Slideshow of Layouts](#)).
2. Click anywhere on the remote Client's monitor layout diagram, and then on the required monitor's view.

The selected layout will be displayed on a selected monitor of the remote Client.

If a single camera is displayed on the remote Client's additional monitor, you can switch to another camera by selecting it through the local Client.

To edit the remote Client's main or additional monitor layout, do the following:

1. Select (see [The Layouts panel](#)) or configure (see [Creating and deleting layouts](#)) the desired layout on the local Client.
2. Click anywhere on the remote Client's monitor layout diagram.

3. Click the  on the main or secondary monitor layout diagram.

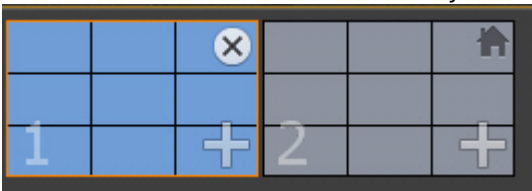

The remote Client's layout is saved, and will be available after rebooting the Client.

You can change the set of cameras to be displayed on the main or additional monitor using the Objects Panel; these changes are not saved, and the initial layout is restored after rebooting the Client. To do it, follow the steps below:

1. Open and lock the Monitor panel (see [Monitor Panel](#)).
2. Open the Objects Panel (see [Objects Panel](#)).
3. Using the Ctrl or Shift keys, select one or several cameras on the panel.
4. Left-click on any selected camera.
5. Drag the camera icon onto a desired cell on the main or additional monitor's layout diagram.
6. Release the mouse button.

Another way to put a camera into a desired cell on the main or secondary monitor layout diagram is to capture the camera's icon on the interactive Map (see [Working with the Interactive Map](#)).

To close an additional monitor on a remote Client, click the  button on the monitor's thumbnail.

8.6 Audio Monitoring

8.6.1 General Information

Audio monitoring of a situation is carried out using the microphones that correspond to a video camera surveying the situation.

In different viewing tile modes, different audio monitoring functions are accessible:

1. Live playback mode – listening to sound from a microphone in real time; playing back sound from Client microphone on camera speakers.
2. Archive mode, Alarm Management mode, Archive Search mode– playback of sound recorded from a microphone.

Note

In Archive mode and Archive Search mode, an audio recording can be played back only from the microphone corresponding to the currently selected video camera, and only in forward playback mode at a speed of 1x.

8.6.2 Listening on the Client to sound from a camera microphone

Attention!

The **Microphone** object must be enabled (see the section titled [The Microphone Object](#)).

To listen on the Client to sound from the microphone of a camera, left-click to activate the speaker icon in the viewing tile.

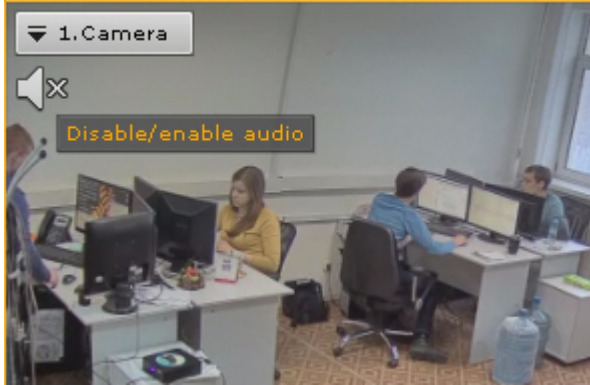

Note

Audio from only one camera can be played back at a time

The speaker icon now becomes active and a volume slider appears.

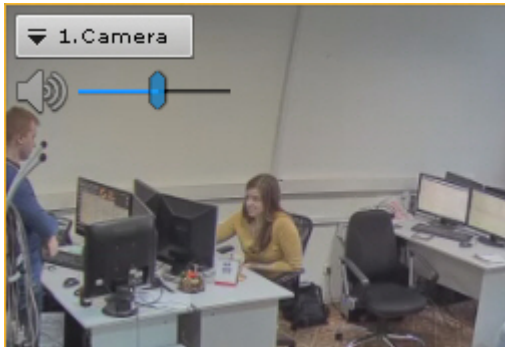

Volume is controlled using the volume adjuster.

The far left position of the adjuster represents the minimum volume, and the far right position represents the maximum volume.

Note

The *Axxon Next VMS* has an embedded sound booster.

To turn off audio playback, click the speaker icon again.

If a camera has several microphones connected, use the following procedure to select the audio source:

1. Open the camera's context menu.

2. Select **Sound**.

3. Select the microphone you need.

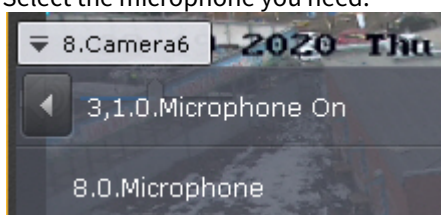
**Note**

The currently selected microphone is marked as **On**. If you select a **8.0** microphone, the **3,1.0** microphone is set to off, and **8.0** microphone to on.

Note

If a currently specified loudspeaker goes offline, the system automatically switches to another available one.

After the first loudspeaker goes back online, no automatic switching will occur.

To automatically activate the first loudspeaker in such a case, you have to create a `NGP_PORTSOUND_HOSTAPI` system variable and set it to DS (see [Appendix 10. Creating system variable](#)).

8.6.3 Playing back sound from Client microphone on camera speakers

Audio transmission from the Client's microphone behind NAT to the Server's or camera's loudspeaker

Sound from the Client microphone can be broadcast both on a single camera and on all cameras in a layout.

Attention!

To use this option:

1. Configuration of audio on the Client is now completed (see [Configuring audio on the Client](#)).
2. **Speaker** objects are activated for the corresponding cameras (see [The Speaker Object](#)).

To broadcast sound on the speaker of a single camera, left-click the microphone icon in the viewing tile.

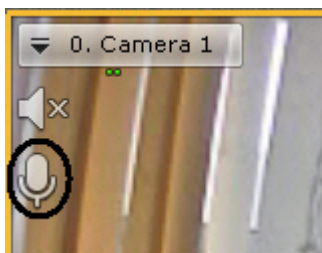

The microphone icon now becomes active.

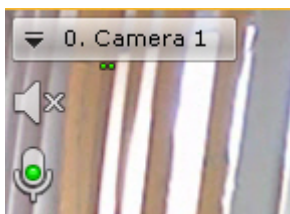

To turn off broadcasting of sound on a camera speaker, click the microphone icon again.

To broadcast sound on speakers on all cameras in a layout, in the context menu of the layouts ribbon, select **Enable audio for all**.

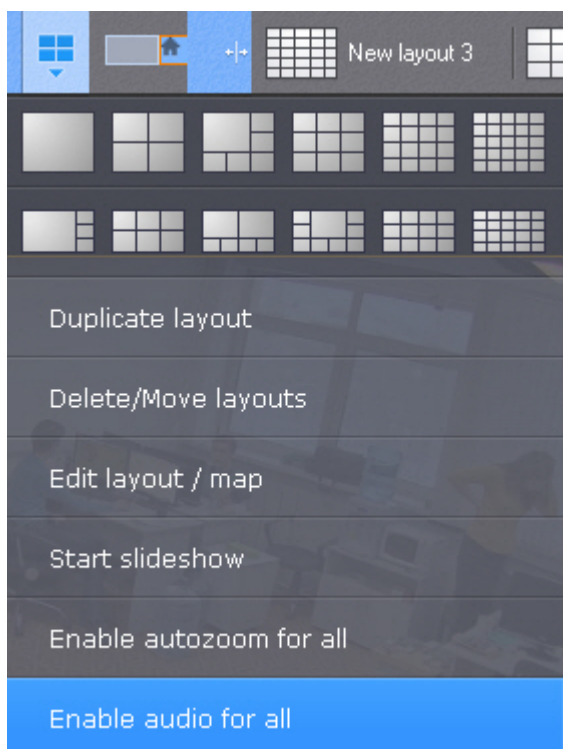

The microphone icon is then activated for all cameras that have an activated **Speaker** object.

To turn off sound broadcasting on all cameras, select **Disable audio for all**.

8.7 Working with the Interactive Map

You can use the interactive map in three modes;

1. 3D mode, in which both the map and layout are available
2. 2D mode, in which only the map is available
3. immersion mode, in which video is overlaid on the map

The map can contain icons for cameras, inputs, and outputs. The area in which live video is displayed and field of view are indicated for each camera.

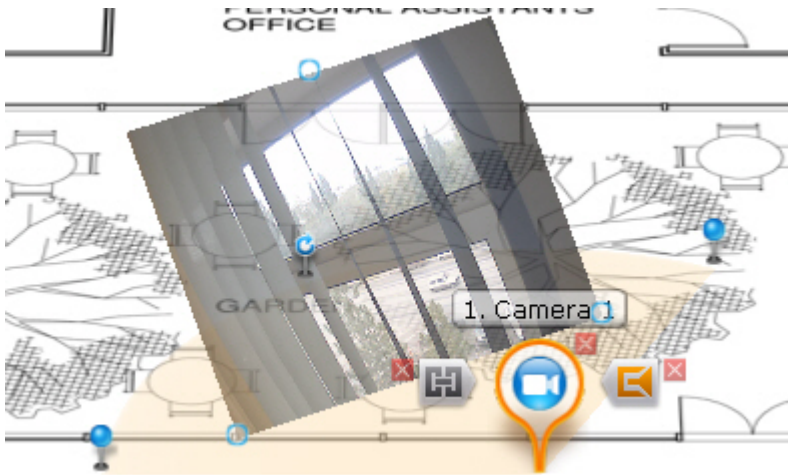

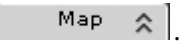

8.7.1 Opening and closing the map

You can switch to Map View from all modes of operation except for Archive Search.

To go Map View, click the **Map** button in the bottom right corner .

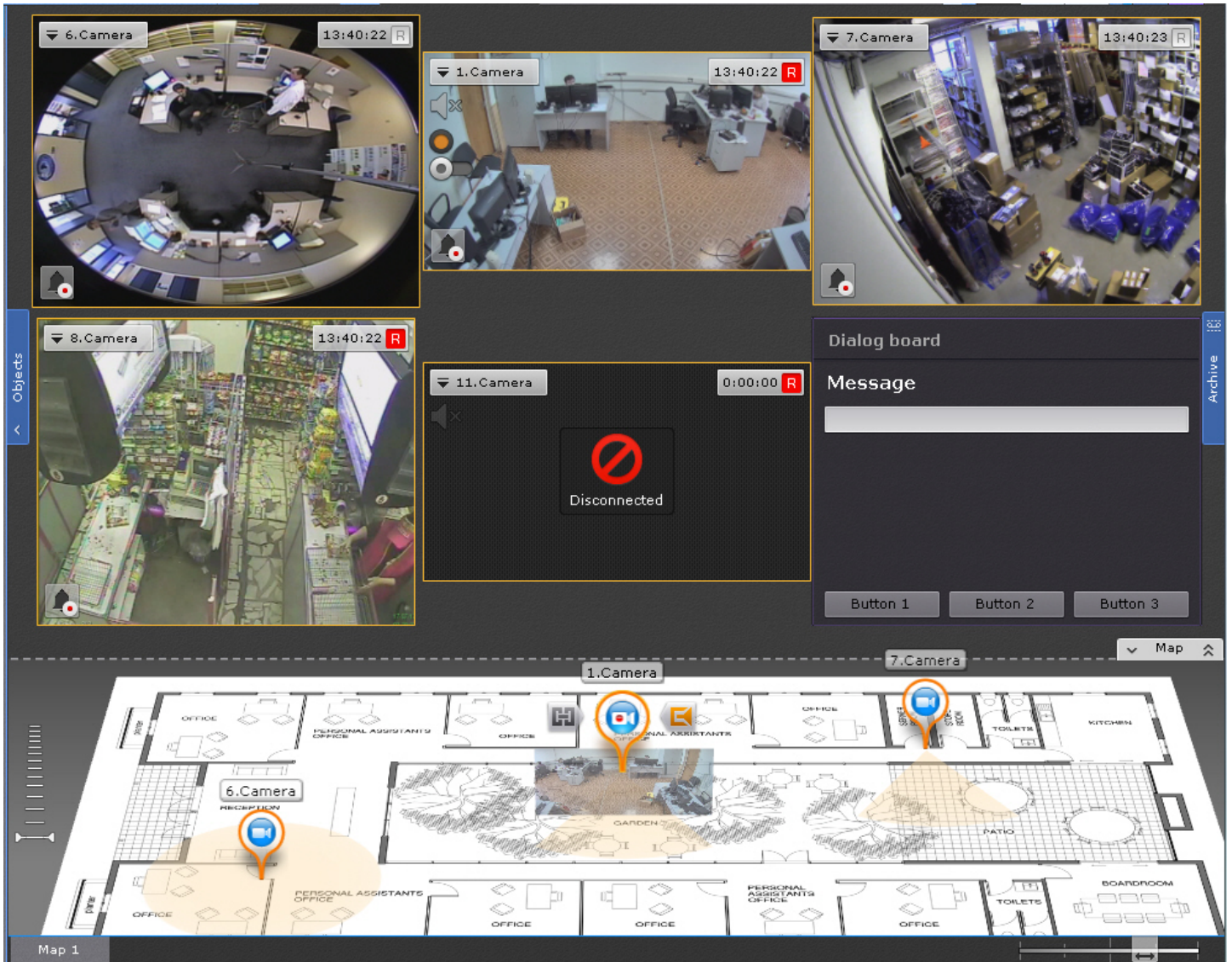
The Map will open in a 3 D view while the current layout contracts to fit the screen area over the map.



To switch to 2D map view and close the layout, click the  button to the left of the **Map** button.

If you expand a tile to full screen, the map auto-hides (see [Scaling the Viewing Tile](#)).

Note

When you minimize the tile, the map appears again.

8.7.2 Geo map search

Using the OpenStreetMap web service, you can search for sites or streets within a pre-defined city/town (see [Setting keywords for geo map search](#), refer to [the provider's website](#) for details).

To do so, enter the street name in the corresponding field, and press **Enter**.

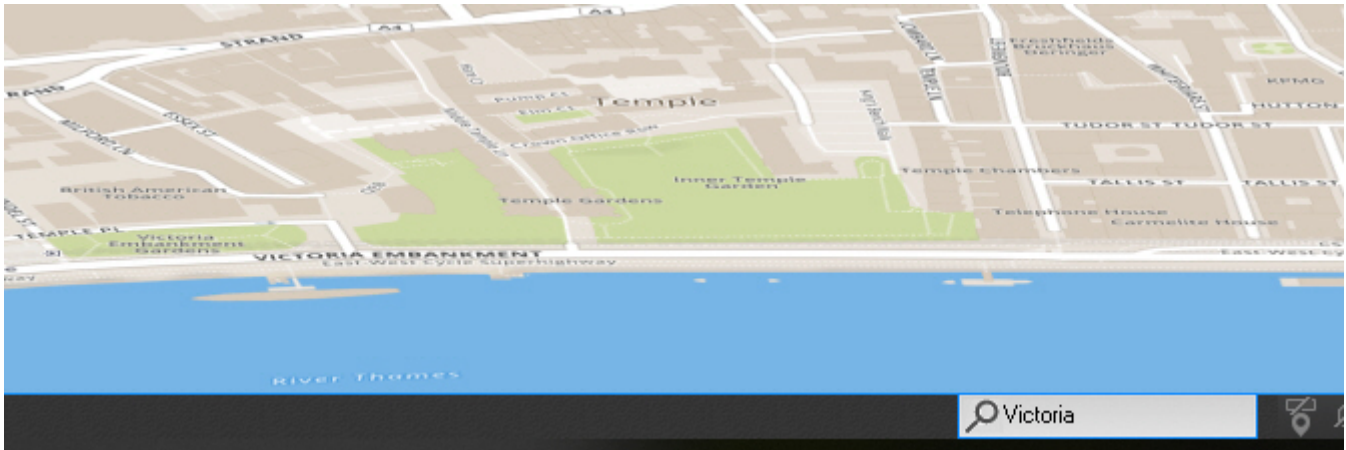

8.7.3 Changing the map tilt

You can change the tilt of the map by adjusting the border between the map and the layout areas.

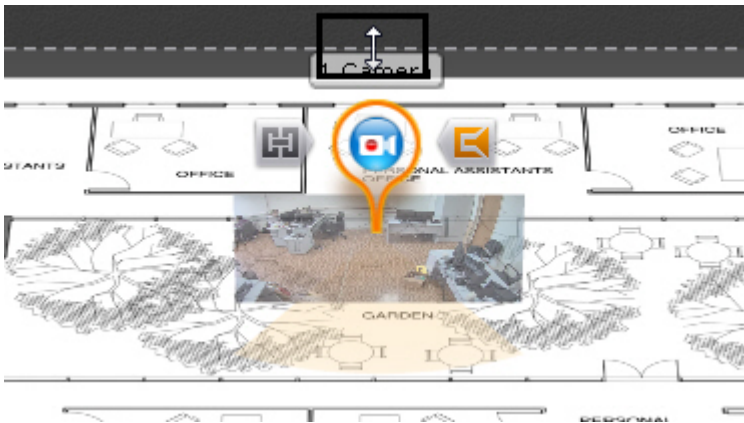

To switch to 2D map view and close the layout, click the  button to the left of the **Map** button.

Note

You can also switch to 2D when the map is hidden.

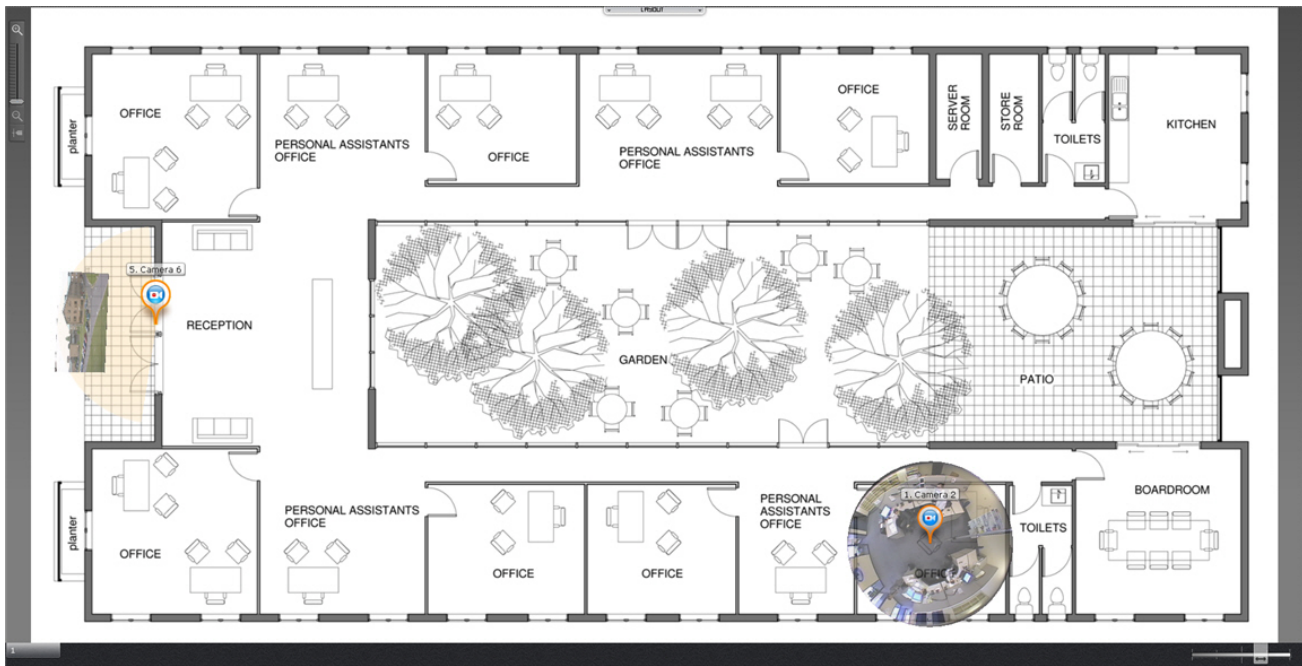

To return to 3D, click the **Map** button. To close the map, click the  button.

8.7.4 Scaling and focusing of map

Map scale and focus can be changed both manually and automatically.

Note

The map is automatically resized and refocused if this function is activated in the settings (see [Configuring map autozoom](#)).

Automatic adjustment of map scale and focus occurs when a video camera alarm occurs, if no video camera icon is selected on the map.

In this case, the map is scaled and refocused to center the icon for the alarm camera on the map.

If alarms occur for several video cameras simultaneously, the map scale and position are adjusted to show all icons for the relevant video cameras.

After a video camera alarm ends and there are no alarms for other video cameras, the map scale and position return to their initial status.

Automatic scaling and focusing of the map stops during the following actions:

When the user clicks to select the icon of a video camera on the map or viewing tile

To manually adjust the map scale, use the mouse scroll wheel (the cursor must be above the map) or use the map scale slider.

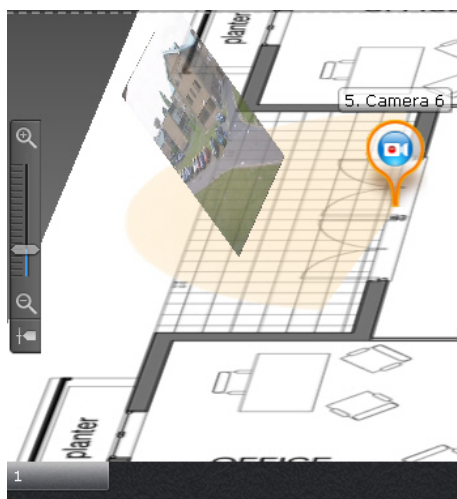

After increasing the scale, you can refocus the map with the mouse (by clicking and holding the left mouse button) in the direction of your choice.

8.7.5 Customizing an Interactive Map

You can change some of the map settings in Live Video. Use the controls in the bottom right corner of the screen.

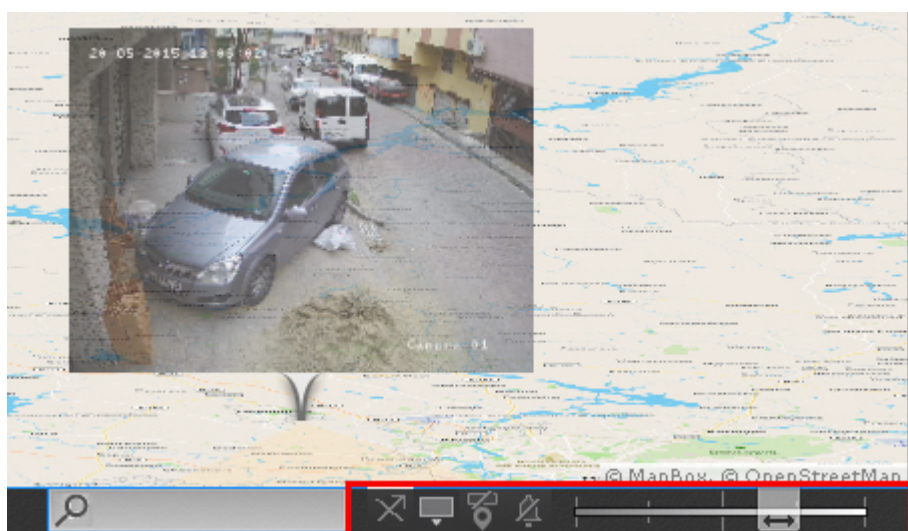

You can adjust transparency of video display in the Map View using a dedicated slider in the bottom right corner.



The leftmost position corresponds to no video, the rightmost makes the video opaque.

Use the







button to toggle the display of devices' names and their IDs.

To enable/disable camera icon fluttering on alarm, use the



button.

To change the action when you click on the video camera icon on the map, use  (takes you to the layout with the camera) /  (switches to immersion mode (see [Immersive mode](#))).

To change map view, use the button  (3D view) /  (flat view).

Video in 3D view:

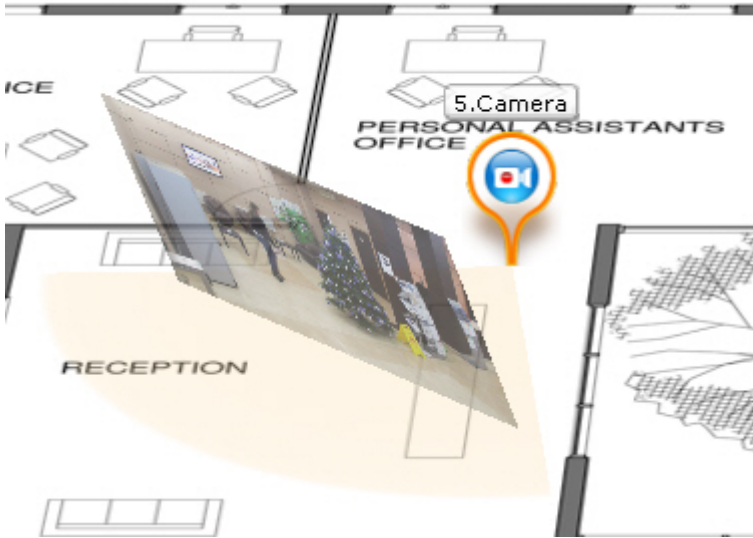

Video in flat view:



8.7.6 Immersive mode

In immersion mode, video from a selected camera is overlaid on the map display.

If links have been created between video and the map (see [Configuring cameras in immersion mode](#)), an angle will be chosen so that objects in the video match the objects as depicted on the map.

If links have not been created, the map is shown so that the video is located in the field of view specified for the camera on the map. The field of view is oriented upwards.

To switch to immersion mode, click the  button on the left border of the viewing tile or, on the map, left-click a video icon, field of view, or video display area.

Note

The second method is possible if the button is not pressed  (see [Customizing an Interactive Map](#)).

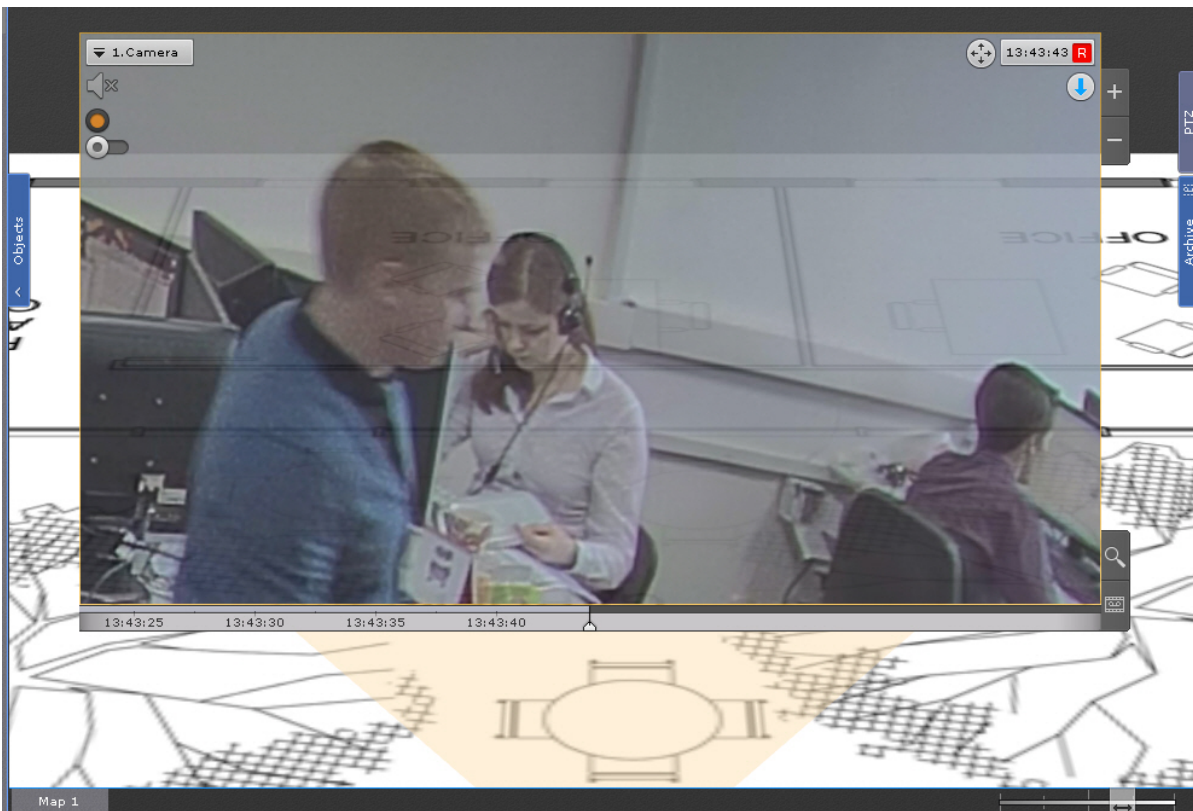



In immersive mode you can view video from only one video camera at a time.

To select another video camera, do one of the following:

1. Click the video camera icon or its field of view on the map, if possible.
2. Exit immersive mode and select the necessary video camera on the map.

To exit immersive mode, do one of the following:

1. Click the  button.
2. Minimize the viewing tile by clicking the  button.
3. Click a part of the map that does not contain the camera field of view.

Note

Actions 2 and 3 do not apply if a fisheye camera is in immersive mode (see [Fisheye cameras in immersive mode](#))

8.7.7 Switching between maps

In any mode, you can switch between the maps that have been created in the system.

You can switch between maps in two ways:

1. In the lower-left corner of the screen, select the corresponding tab

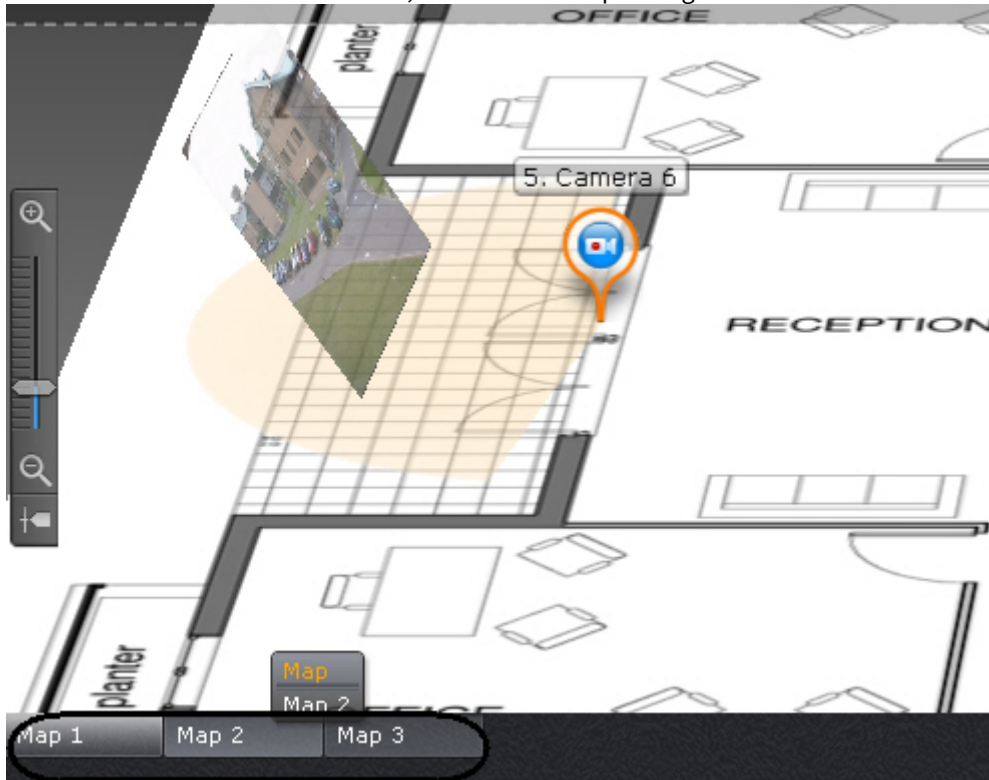
**Note**

If many maps have been created, some tabs may not fit on the screen. If this happens, click the  button. In the drop-down menu that opens, select a map.

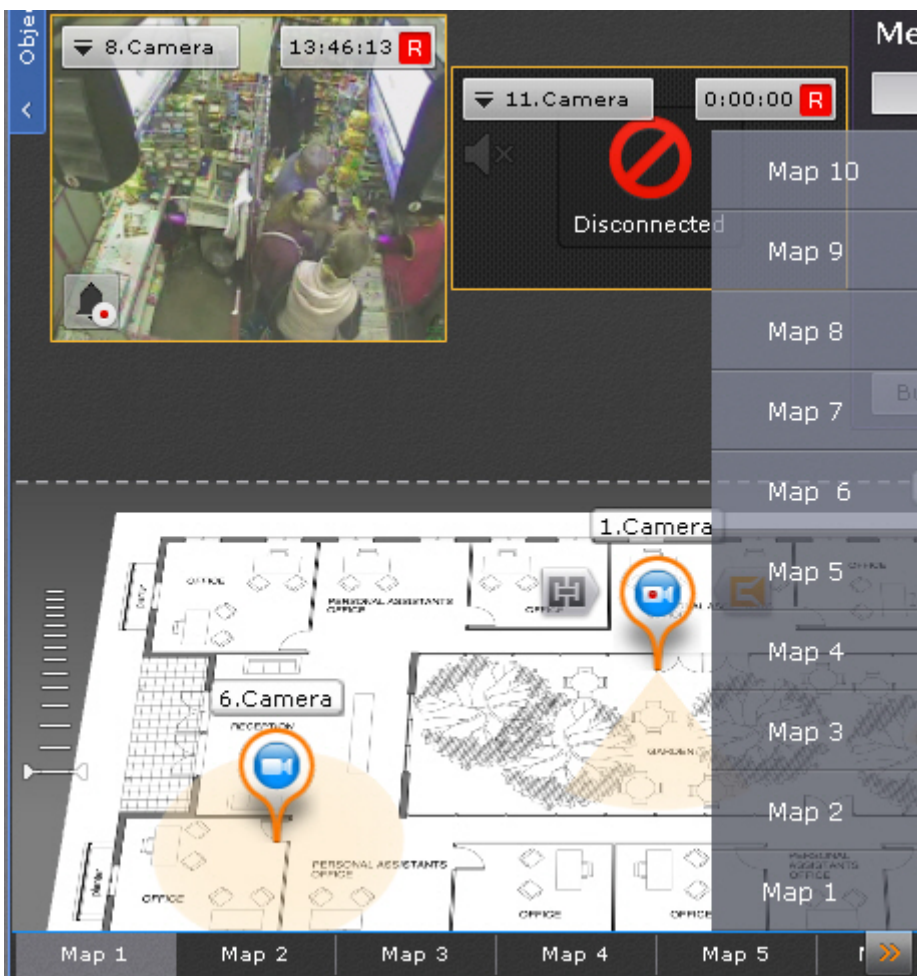

- By left-clicking a map icon for switching, if it has been created (see [Adding switches to another map](#)). The icon header shows the name of the destination map.



8.7.8 Controlling devices from the map



You can manage devices on the map (video cameras, Outputs) by using the context menus of the corresponding icons. You can control devices in all modes.

Commands for controlling video cameras are given in the table below.

Command (context menu item)	Condition	Icon status after the command is performed
Arm	The camera is disarmed	
Private Arm Arming and Disarming a Video Camera	The camera is disarmed	

Disarm	Camera armed	
--------	--------------	---

Commands for controlling outputs are given in the table below.

Command (context menu item)	Condition	Icon status after the command is performed
Turns the output on	Output in normal status	
Disable output	Output is activated	







Note

From within the map, you cannot switch the status of the Output if there are macros with the corresponding action running in the system



8.7.9 Displaying device status

The icons on the map indicate the current status of the corresponding devices.

The table below possible status states of the video camera icon are described in the following list.





Map icon	Camera status
	Camera disarmed, no archive recording
	Camera disarmed, archive recording active
	Camera armed, no archive recording
	Camera armed, archive recording active
	Camera alarm, archive recording active
	Camera connection lost

The table below possible status states of the Output icon are described in the following list.

Map icon	Output status
	Output is activated
	Output in normal status

Note
 When a macro changes the Output status, the Output icon on the map does not change.

The table below possible status states of the Input icon are described in the following list.

Map icon	Input status
	Video camera is armed, Input is in normal status
	Video camera is armed, Input is in alarm status
	Video camera is disarmed, Input is in normal status
	Video camera is disarmed, Input is in alarm status

Inputs (sensors) connected to Tibbo boards also show temperature/humidity values on the map.

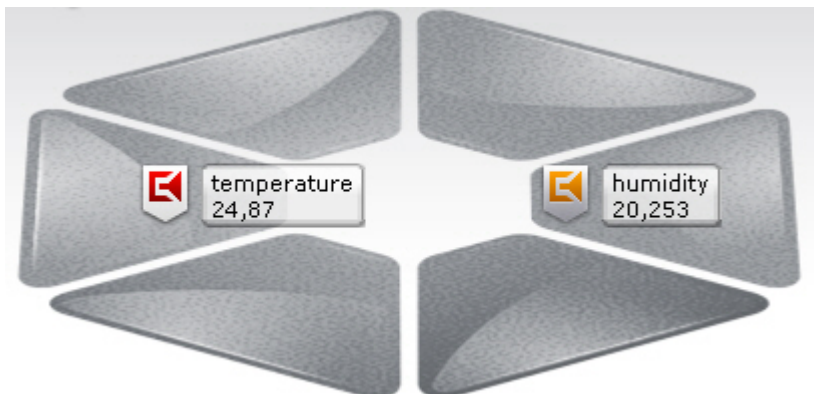

8.7.10 Selecting Cameras for a Temporary Layout

You can use the Map to select cameras for viewing their video feeds on a temporary layout.

Do the following:

1. Press and hold Ctrl, and left-click camera icons.

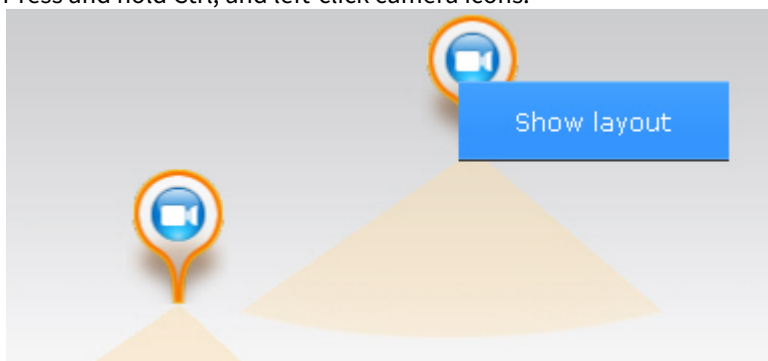

2. Click the **Show Layout** button.

The selected cameras' views appear on the temporary layout which is not preserved after you switch to any other layout.

8.8 Exporting Frames and Video Recordings

Users with the corresponding rights can export snapshots and video. If a Client is connected to multiple Axxon-domains, export of snapshots and video is available only for cameras on the Axxon-domains on which the user has the corresponding rights.

Still frames can be exported to JPG and PDF, videos can be exported to AVI, MP4, MKV and EXE formats.

Exported videos will contain synchro audio.

The name of the exported file contains the following information: name of camera, export date, and export duration.

Note.

The date and time of the event in the file name are given based on the Windows locale settings.

Note.

The file name can be up to 70 characters long.

When exporting a snapshot to PDF, you can also print the document immediately.

A digital watermark is added to exported snapshots and video. Watermark authentication is available in the corresponding bundled utility (see the [Digital Signature Verification Utility](#) section).

Note

Exported videos and snapshots are digitally signed with the SHA-256 algorithm.

Titles containing a date and time stamp will be superimposed on exported video.

Note.

Captions are stored in a separate video track and, if necessary, are disabled in the player through software.

8.8.1 Frame export

You can export snapshots at any time when working with a camera in Axxon Next.

To export a snapshot:

1. If exporting from archive mode or archive analysis mode, specify an export area and mask if necessary (see the [Configuring export area and masks](#) section).

- In the viewing tile, in the upper-right corner, click the  button.

Attention!

To instantly export a frame with standard settings, right-click the  button.

- Specify the folder to which you want to export the snapshot (1).

Note.

By default, snapshots are exported to the folder specified in the export settings (see the [Configuring export](#) section).

If you change this folder, the new path to exported files will be kept in memory until the Client restarts.

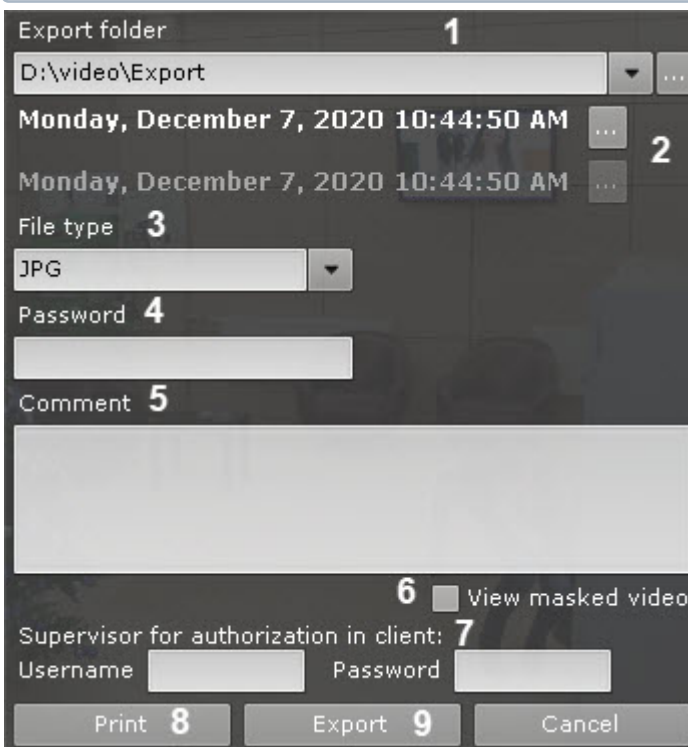

- Select the date and time for a snapshot (2). The default setting is the frame currently displayed in the viewing tile. If you are watching recorded video, then the snapshot with the frame displayed at the time when you hit the button

Note.

If you are watching live video, then the snapshot with the frame displayed at the time when you hit the button. Date and time fields are not displayed.

- Select the snapshot format: PDF or JPG (3).
- If you want to export a snapshot to an encrypted zip archive, set a password (4).

Attention!

This setting may be overridden by the user role settings (see [Creating and configuring roles](#)).

- If exporting a snapshot to PDF format, you can add comments (5).

8. To export unmasked frames from the Video Footage, the user must have appropriate access rights. To perform such an export, check the **View Masked Video** box (6).
9. Enter the credentials of the supervisor who confirms the launch of export (7).

Note

The supervisor enters their password only if it is required by user rights settings. If no export confirmation is required, these fields will not be displayed.

10. If exporting to PDF, you can immediately send the file to print (8). In this case, the snapshot is not saved to disk.
11. To export the snapshot, click the corresponding button (9).

Export begins. Progress is shown in the export panel (see the [Viewing export progress](#) section).



Export of the frame is now complete. The frame exported to JPG will also be placed on the Clipboard.

8.8.2 Exporting Video Recordings



8.8.2.1 Standard video export

Standard export of video takes place as follows:

1. An export range (timeframe) is set.
Set the export interval on the primary or secondary timeline. You can do it later by entering the date and time (see item 3c below):

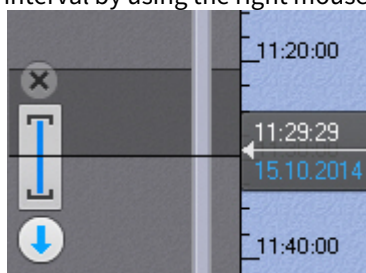
- a. on the main timeline, move the bar to the beginning of the range that you want to export. Click the  button.
Move the bar to the end of the range that you want to export. Click the  button. You can also select the export interval by using the right mouse button. To clear the interval, click the  button;



- b. you can specify the range on the additional navigation panel in the same way, by clicking the   buttons. You cannot use the mouse to set the export range on the additional navigation panel.
2. Setting export area and masks (see the [Configuring export area and masks](#)).
3. Setting an export format, specifying where to save exported files, and adding comments.
 - a. On the timeline or in a viewing tile, click the  button.
The export window opens.

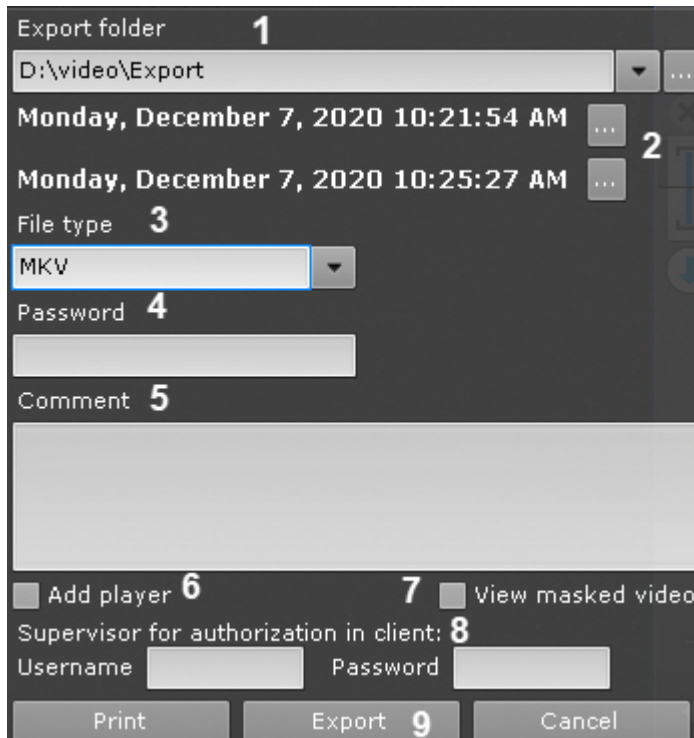

- b. If necessary, change the export path (1). By default, the file is exported to the folder specified in the settings (see the [Configuring export](#) section). If you change this folder, the new path to exported files will be kept in memory until the Client restarts.
- c. You can set the start and end time of the exported episode in the calendar (2).

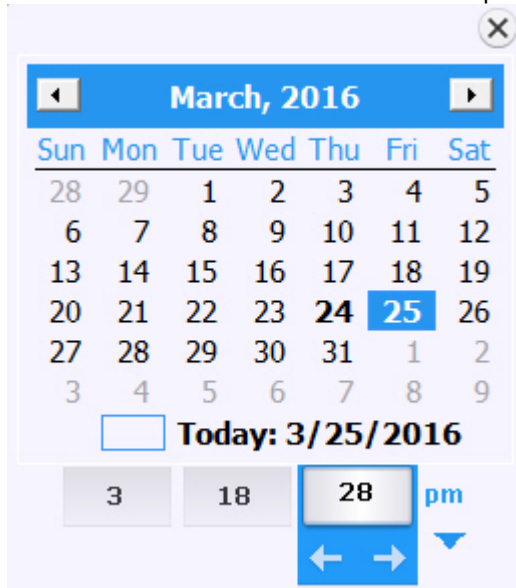

- d. If necessary, specify a different file format for exporting the video (3). Videos can be exported into the following 4 formats: MP4, MKV, EXE and AVI.

Note.

Video is exported in MKV format without recompression.

Video is exported in AVI format with recompression in the selected codec (see point 4). Export to AVI files may take longer time because of recompression.

In addition, AVI export increases CPU load, especially when you export several files at once (see [Simultaneous export of video from multiple cameras](#), [Exporting all event videos](#)).

When video is exported in EXE format, a self-contained executable file is generated, containing video, playback tools, and necessary codecs.

When exporting to EXE format, please note that Windows does not allow launching executable files of more than 4 Gb.

- e. If you want to export to an encrypted zip archive, set a password (4). If you are exporting an .exe file, you will need to enter a password when you open the file.

Attention!

This setting may be overridden by the user role settings (see [Creating and configuring roles](#)).

- f. If necessary, add comments for the export. The comments will be shown as captions when the exported video is played (5).
- g. If you export a video to MKW or AVI format, and you need to copy the Axxon Player utility (see [The Axxon Player User Guide](#)) to the same folder, check the corresponding box (6).
- h. To export unmasked videos from the Video Footage, the user must have appropriate access rights. To perform such an export, check the **View Masked Video** box (7).
- i. Enter the credentials of the supervisor who confirms the launch of export (8).

Note

The supervisor enters their password only if it is required by user rights settings. If no export confirmation is required, these fields will not be displayed.

- j. Click the **Export** button (9).

The export process begins. Progress is shown on the export panel (see the [Viewing export progress](#) section).

Note.

You can stop export at any time by clicking the **Stop** button.

Note.

The duration of the exported file can be longer than the specified one, because the keyframe is not always at the beginning of the export interval.

8.8.2.2 Instant video export

You can instantly export video without needing to specify an export range. To do so, click the  button in a viewing tile at any time.

Note.

Then specify export settings, as described in the [Standard video export](#) section.

If export is performed from Live Video mode, the first frame of the exported video will be the moment when the  button was clicked. Export will continue for 10 minutes or until the **Stop** button on the export panel is clicked (see the [Viewing export progress](#) section).

If export is performed from archive mode or archive analysis mode, the first frame of the exported video will be the position of the bar on the timeline when the  button was clicked. Export will continue for 10 minutes or until the **Stop** button on the export panel is clicked (see the [Viewing export progress](#) section).

The length of the exported video clip will depend on the time of export and resources of the Server.

Note.

If export is performed from archive mode or archive analysis mode, you can pre-configure an export area and masks (see the [Configuring export area and masks](#) section).

8.8.2.3 Simultaneous export of video from multiple cameras

If multiple cameras in a layout have been switched to archive mode, you can simultaneously export video from all of them.

To do this, select the export interval on the primary timeline or in the calendar and start exporting (see the [Standard video export](#) section).

By default, the video is exported to a single file. To export video from different video cameras to separate files, deselect the **Export as single file** check box in the export window.

Note.

When you export to one file, the streams are written in parallel. To view exported video, use a player that allows playing multiple instances and different streams in each (for example, VLC).

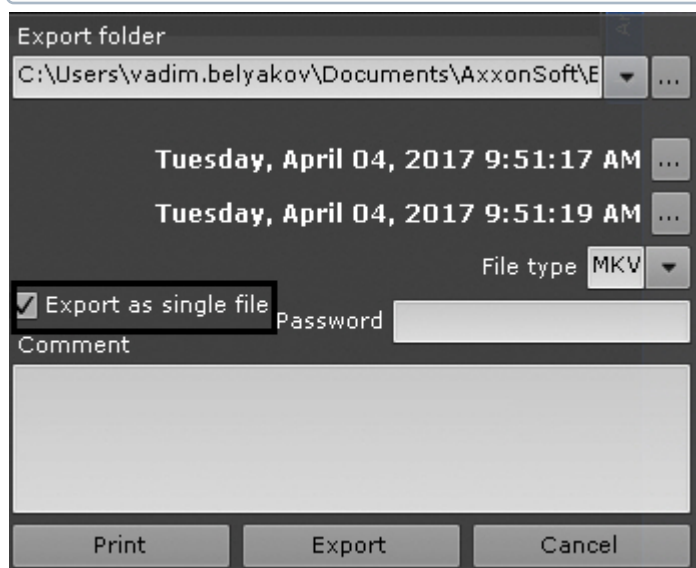

Video from each camera is exported to a separate file. Comments made during export are added to each exported video.

Note.

For each video you can pre-set an export area and masks (see the [Configuring export area and masks](#) section).

8.8.2.4 Exporting all event videos

You can use the Story board (see [Story board](#)) for one-click export of an event video from multiple cameras' Video Footage.

To do so, follow the steps below:

1. Click on the thumbnail of interest.
2. Set a time interval on the timeline for export.
This will add the thumbnail of the selected video clip to the Story board.



3. Click the + button in the middle of the thumbnail. The video clip will be added to the export batch.

Note

To remove it from the batch, click the button.

4. Repeat these steps for all videos of interest.
5. Click the button to export all selected clips.

By default, the video is exported to a single file. To export video from different video cameras to separate files, deselect the **Export as single file** check box in the export window.

Note.

When you export to one file, the streams are written in parallel. To view exported video, use a player that allows playing multiple instances and different streams in each (for example, VLC).

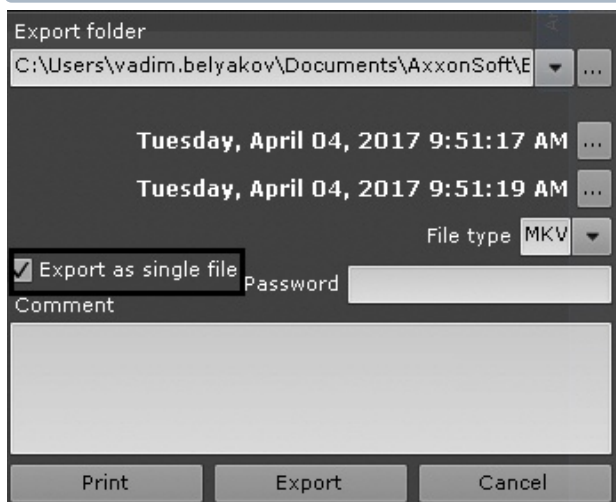

This opens the Export window. Follow the same steps as with the standard export procedure (see [Standard video export](#)).

Note

We recommend you to export to the EXE format.

8.8.3 Configuring export area and masks

If you are exporting a snapshot or video from archive mode or archive analysis mode, you can specify an export area and masks.

You can specify an export area and masks at the same time.

By specifying an export area, you export only the portion of the frame that is of interest, while omitting the remainder.

To specify an export area:

1. In a viewing tile, click the  button.
A rectangular area with four corner points is displayed.

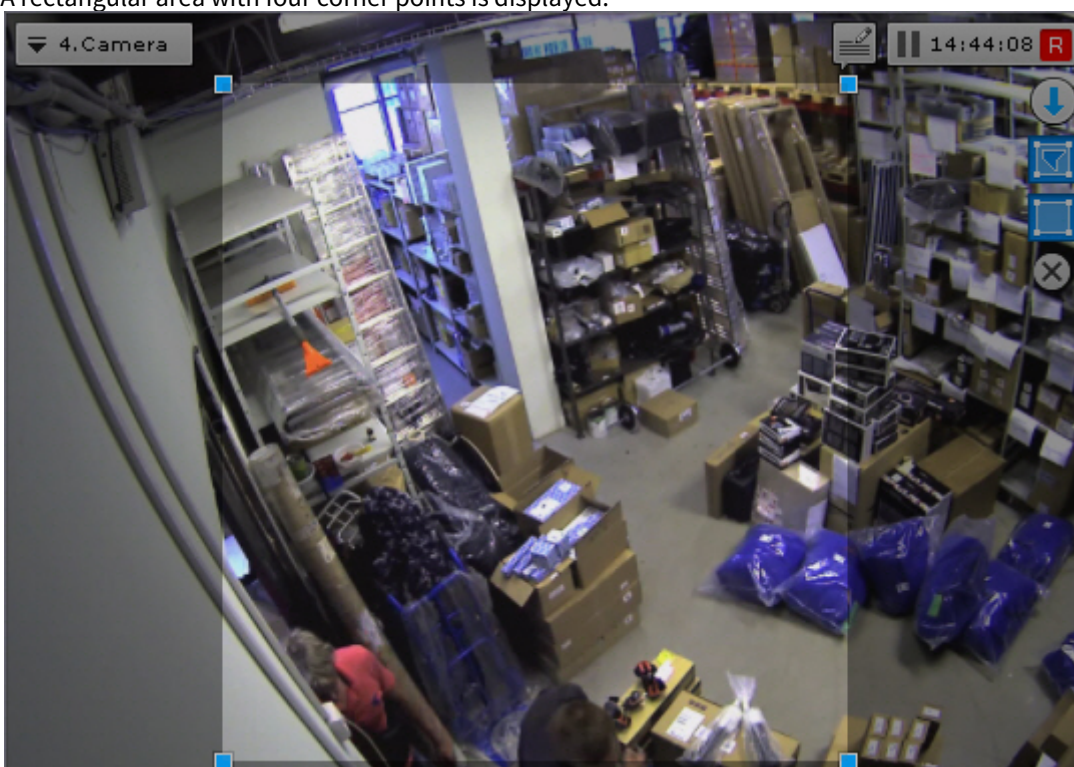

2. Reposition the corner points to specify the area that you want to export. To reposition the corner points, left-click a corner point and drag it.

Configuration of the export area is now complete.

Masking allows you to hide complex or irrelevant areas of the frame so that they do not appear in an exported file. You can set an unlimited number of masks.

To specify a mask:

1. In a viewing tile, click the  button.
2. Use the corner points to enclose the area that you want to mask. To add a corner point, left-click the video. You can add an unlimited number of corner points.

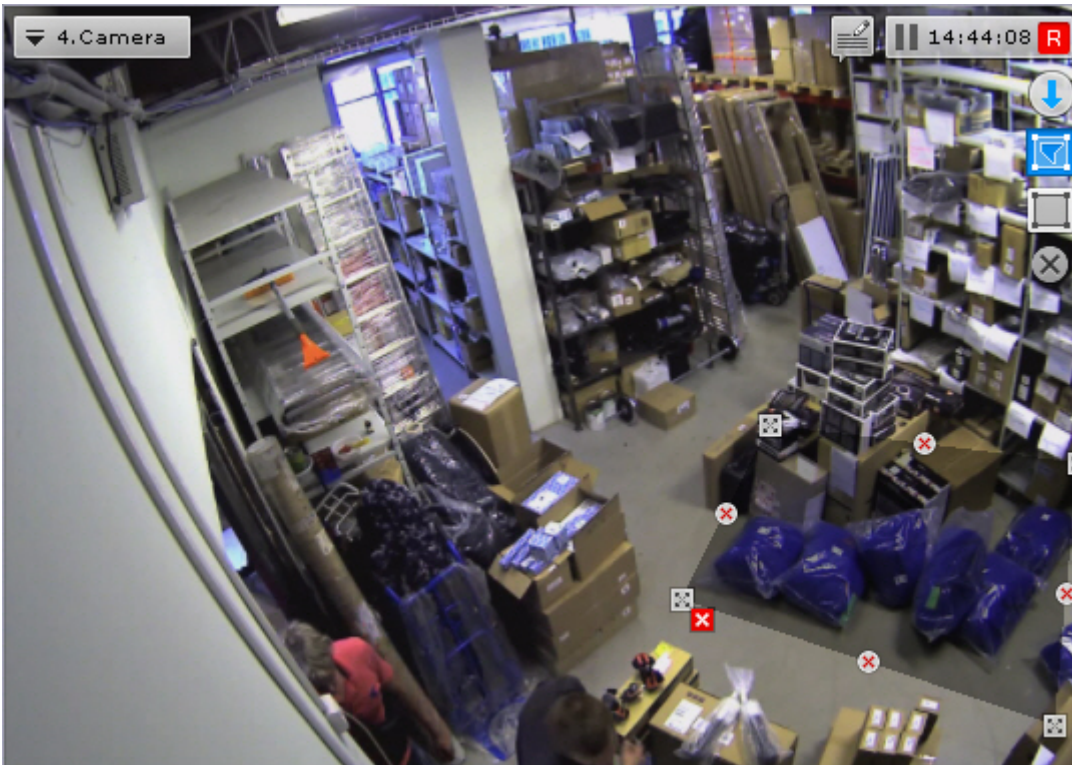

After you add a mask, you can perform the following actions:

- Move corner points (left-click a corner point and drag it).
- Delete corner points (right-click a corner point).
- Delete a mask (click the  button).
- Add a new mask.

Mask creation is now complete.

In the exported snapshot or video, the masked area is filled in with black.





8.8.4 Viewing export progress

After export is started, the export progress is displayed on the export panel. The export panel is displayed near the top of the monitor after the export process is started, and is hidden after all messages are closed.



To stop the export process, click the **Stop** button. In this case the file will be saved. The length of the exported fragment will depend on the export time and resources of the Server.

To cancel export, click the **Cancel** button. In this case, the file is not saved.

If several export processes are active, you can switch between them by clicking the   buttons. The following information is displayed between them: number of the current export operation / total number of export operations (export progress for all operations).

To close the export progress message, click the  button.

Note.

If export is active, you cannot close the message.

If an error occurs during export, it will be indicated on the dynamic error panel (see [Control in Live Video Mode](#)).

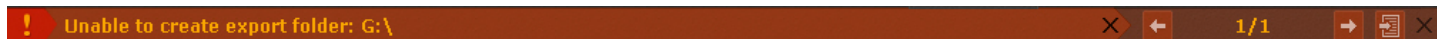

8.9 Macros control

A macro may include settings (see [Create Macros](#)) to display the  control menu in the upper panel.



Those macros that are currently active (enabled as **Always** or within a time schedule, see [Create Macros](#)), are marked as **(On)**.

To enable or disable macros you need to select them in the list. When you disable a macro, the mode is changed to **Never**.

Note

If you disable a macro, which is active within the time schedule, then this mode will be restored after reactivation.

Note

The status of the macro in the menu changes only a few seconds after a command is completed.

Event-driven macros can be triggered by using the corresponding buttons on the Dialog board (see [Working with Dialog Board](#)) or by using hotkeys.

8.10 Event Control

Event control in the Axxon Next software package can be conducted in three ways:

1. In Live Video mode
2. Using the system log
3. By logging events in external logs

Note

Configuration of logging to external files is carried out through the log management utility (see the section [Log Management Utility](#)).

8.10.1 Control in Live Video Mode

Messages about system errors which have occurred are displayed in real time on a dynamic error panel. When there are no unaccepted errors, this panel is not displayed; when there are such errors, it is displayed in Axxon Next's **Layouts** tab.

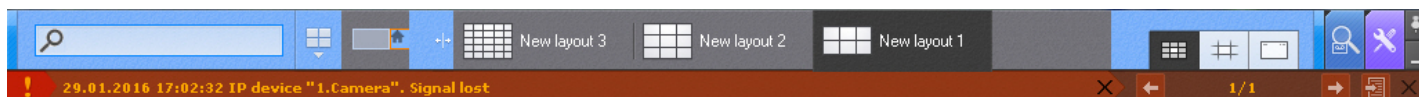



Note

This feature is configured on the **Permissions** tab (see the section [Creating and configuring roles](#)).

To accept an error and delete it from the error panel, click the cross.

To accept all errors and close the error panel, click the cross on the right-hand side of the panel.

To switch between error messages, click the   buttons.

To jump to System Log (see [The System Log](#)), and open error messages, click the  button.

8.10.2 The System Log

Information about events which have occurred in the system is stored in the system log.

To access the system log, select **Settings** -> **System log**.

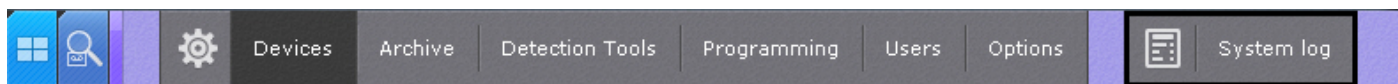

When you do this, a window appears which can be used to search, view, and export system log events.

8.10.2.1 Setting Event Search Filters

To view and/or export system log events, first you need to perform a search for them.

To search for system log events, you need to set one or more filters:

1. Time period during which the events were recorded.
2. Event type:
 - a. Information;
 - b. Alarm;
 - c. Error;
 - d. Debug;
 - e. Audit - user actions log.
3. A key phrase contained in the system event descriptions.

Note

The time period is a mandatory filter, while the event type and key phrase are optional.

Search filters can be set as follows:

1. In the **To** and **From** fields (1) you can enter the date and time of the beginning and end of the period during which the events you are searching for were recorded.

The screenshot shows the 'Filter parameters' dialog in the Axxon Next software. The 'From' field is set to 29.01.2016 0:00:00 and the 'To' field is set to 29.01.2016 23:59:59. The 'Event type' list includes 'Debug info', 'Info', 'Alarm', 'Error', and 'Audit', all of which are checked. The 'Available Axxon-domains' dropdown is set to 'All Axxon-domains'. The 'User' dropdown is empty. The 'Search' text box contains the number '5'. There are 'Back', 'Next', 'Search', 'Export', and 'Clear' buttons.

Note

The date format is DD-MM-YYYY and the time format is HH:MM:SS.XXX.

Note

By default, the event search period is defined as the past 24 hours.

2. Selecting event types for search (2).
3. Select the Axxon domain where you need to search for events (3).
4. If user actions search was selected (the **Audit** type), choose a particular system user (4). If no user is selected, the search function will return actions of all system users.
5. Enter the text that matches the events you want to find in the **Search Text** field (5). To find license plate numbers, enter the full or partial number. Use ? (any one character) and * (any number of any characters). For example, a search query ? 20* shows all vehicles with a license plate containing 2 and 0 in the second and third position respectively. The total number of characters in number plates can be arbitrary.

Attention!

You can use OR and AND logical operators when searching data in the system log.

- to search with the OR logical operator, separate the words with the symbol "|";
- to search with the AND logical operator, use a space.

The event search filters have been set.

Next you must start the event search (see the section titled [Event search procedure](#)).

8.10.2.2 Event search procedure

To start a search for system log events which satisfy the filters which have been set (see the section [Setting Event Search Filters](#)), click the **Search** button (1).

Filter parameters

From: 29.01.2016 0:00:00 To: 29.01.2016 23:59:59

Event type: Debug info, Info, Alarm, Error, Audit

Available Axxon-domains: All Axxon-domains

User: [dropdown]

Buttons: Back, Next, Add new events to results of the search, Search, Export, Clear

Date & time	Event type	Description
29.01.2016 17:01:53	Audit	Export on device "8.Camera" of Server "V-BELYAKOV" from archive "". Full path "C:\Users\vadim.belyakov\..."
29.01.2016 17:01:48	Audit	Export on device "2.Camera" of Server "V-BELYAKOV" from archive "Archive AliceBlue". Full path "C:\Users\v..."
29.01.2016 16:39:05	Audit	Parameter "Enable" of speaker "2.0.Speaker" of device "2.Camera" set to "Yes"
29.01.2016 16:36:21	Audit	Login to Server "V-BELYAKOV", user "root"
29.01.2016 16:34:53	Audit	Logout from Server "V-BELYAKOV", user "root"
29.01.2016 16:34:20	Audit	Parameter "Enable" of microphone "1.0.Microphone" of device "1.Camera" set to "Yes"
29.01.2016 16:18:00	Audit	Device "7.Camera" of Server "V-BELYAKOV": Alarm classified as critical
29.01.2016 16:17:59	Audit	Alarm classified on device "7.Camera" of Server "V-BELYAKOV"

When you do that, a search results table appears (2).

To accept all errors and close the error panel, click the **Clear** button (3).

8.10.2.3 Refreshing Event Search Results

You can automatically refresh the event search results table, i.e., add events to it which happened after the search was started (see the section [Event search procedure](#)). To do this, select the **Add new events to the results of the search** check box.

Filter parameters

From: 29.01.2016 0:00:00 To: 29.01.2016 23:59:59

Search: [input] Search

Buttons: Back, Next, Add new events to results of the search

Note

Select this check box to update events automatically with no need to search again.

8.10.2.4 Viewing Event Search Results

System log event search results are displayed in a table (1).

Note

Events in the table are sorted by the date they were registered, beginning with the most recent one.

Filter parameters

From: 29.01.2016 0:00:00 To: 29.01.2016 23:59:59

Event type: Debug info, Info, Alarm, Error, Audit

Available Axxon-domains: All Axxon-domains

User: []

Search: []

Add new events to results of the search

Date & time	Event type	Description
29.01.2016 14:16:24	Audit	Armed state on device "7.Camera" of Server "V-BELYAKOV"
29.01.2016 12:50:36	Audit	Disarmed state on device "7.Camera" of Server "V-BELYAKOV"
29.01.2016 12:32:26	Audit	Added detection "Situation Analysis" of device "8.Camera" on Server "V-BELYAKOV"
29.01.2016 11:41:36	Audit	Added device "8.Camera" on Server "V-BELYAKOV"
29.01.2016 11:41:31	Audit	Added device "7.Camera" on Server "V-BELYAKOV"
29.01.2016 11:41:26	Audit	Added device "6.Camera" on Server "V-BELYAKOV"
29.01.2016 11:14:07	Audit	Device "1.Camera" of Server "V-BELYAKOV": Alarm classified as critical

Table column	Contents of column
	Switching to archive video of specific events
Date & time	Date and time the event was recorded in the system in the format DD.MM.YYYY HH:MM:SS
Event type	Event type (information, alarm, debug, error)
Description	System description of the event

The search results table may be more than one page. To navigate through a table which is more than one page, use the following buttons (2):

1. **Back** Goes back to the previous page of the table.
2. **Next** Goes to the next page of the table.

Note

Once the *Axxon Next* VMS is installed, the log may show a **Table end violation** error. This is part of the installation routine and not a bug.

Once the *Axxon Next* VMS is installed, the log may show a **Table end violation** error. This is part of the installation routine and not a bug.

8.10.2.5 Exporting Event Search Results

To export the system log event search results, click the **Export** button.

Event type: Debug info, Info, Alarm, Error, Audit

Available Axxon-domains: All Axxon-domains

User: []

When you do this, the standard Windows “Save as” dialog box appears, using which you can save the search results as a file with a .txt (text) extension or .csv (comma-separated).





Date & time	Event type	Description
23/09/2010 16:49:53	Alert	Camera Camera.
Change in the alert status: alert processed by user root with resolution False alert		
23/09/2010 16:35:45	Alert	Camera Camera.
Alert initiated by user root		
23/09/2010 16:35:43	Alert	Camera Camera.
Change in the alert status: alert processed by user root with resolution False alert		
23/09/2010 16:32:50	Alert	Camera Camera.
Alert initiated by user root		
23/09/2010 16:32:49	Alert	Camera Camera.
Change in the alert status: alert processed by user root with resolution False alert		
23/09/2010 16:28:05	Alert	Camera Camera.
Alert initiated by user root		
23/09/2010 16:28:03	Alert	Camera Camera.
Change in the alert status: alert processed by user root with resolution False alert		
23/09/2010 16:26:11	Alert	Camera Camera.
Alert initiated by user root		
23/09/2010 16:23:41	Alert	Camera Camera.
Change in the alert status: alert processed by user root with resolution False alert		
23/09/2010 16:22:33	Alert	Camera Camera.
Alert initiated by user root		

8.10.2.6 Switching to archive video of specific events

To switch to archive video of specific events, click the  icon next to the event or double-click the relevant row.

Note

Archive viewing can be triggered by events coming from cameras, inputs (sensors) and outputs (relays). To make it work, I/O must be linked to a particular camera (see [The Input Object](#), [The Output Object](#)).

	Date & time	Event type	Description
	29.01.2016 16:18:00	Alarm	!!! MUST LOCALIZE: SystemMessage_AlertState3, Aler
	29.01.2016 16:17:55	Alarm	Camera {ObjectFriendlyName}: Alarm pending
	29.01.2016 16:17:55	Alarm	Camera "7.Camera": Alarm initiated by macro
	29.01.2016 16:17:50	Alarm	!!! MUST LOCALIZE: SystemMessage_AlertState3, Aler
	29.01.2016 16:17:47	Alarm	Camera {ObjectFriendlyName}: Alarm pending
	29.01.2016 16:17:47	Alarm	Camera "7.Camera", Alarm is initiated by user "root"
	29.01.2016 16:14:53	Alarm	!!! MUST LOCALIZE: SystemMessage_AlertState3, Aler
	29.01.2016 16:14:51	Alarm	Camera {ObjectFriendlyName}: Alarm pending
	29.01.2016 16:14:51	Alarm	Camera "7.Camera", Alarm is initiated by user "root"

The system will now switch to archive mode and fetch the video of the selected event.

8.11 Working with Axxon Next Through the Web Client

8.11.1 Web client overview

The web client offers the following options:

1. [Viewing live videos.](#)
2. [Controlling PTZ cameras.](#)
3. [Viewing Archive.](#)
4. [Archive search.](#)
5. [Listening to a camera's microphone.](#)
6. [Exporting still frames and videos.](#)

7. [Digital zooming.](#)
8. [Working with bookmarks.](#)
9. [Viewing Camera and Archive Statistics.](#)

8.11.2 Hardware and software requirements for the Web Client operation

The Web Client operates correctly with the latest versions of Google Chrome, Firefox and Microsoft Edge browsers.

Note

Since no 3rd party technologies are used in the Web Client, it may operate with other browsers; in this case, we cannot guarantee its stable operation.

Attention!

No support for Safari and Internet Explorer is provided in the current version.

To monitor 16 FullHD* camera videos on a single browser tab, you need at least an Intel Core i3 CPU and 1Gb of RAM.

* conditions are:

- dual stream cameras,
- each stream's frame rate is 25 FPS,
- the second stream's resolution is 360p,
- if the layout includes more than one camera, the browser shows streams with lower bitrates.

8.11.3 Starting the web client

Use of Axxon Next through a web client takes place remotely, through a web browser and the TCP/IP protocol. Remote video surveillance via a web browser does not require installation of Axxon Next.

Attention!

Opera browser supports Web-client starting from version 15.

In the Windows OS, the Web-client for Safari browser is not supported.

To start the web client:

1. Start a web browser.
2. In the address bar, type the address of the Axxon Next server in the following format: <web server IP address>:<Port>/<Prefix>.

[Connecting the web and mobile Clients to the Server behind NAT](#)

Attention!

The Server URL is case-sensitive. You have to type in the URL using the exact case of characters specified in settings(see [Configuring the web server](#)).

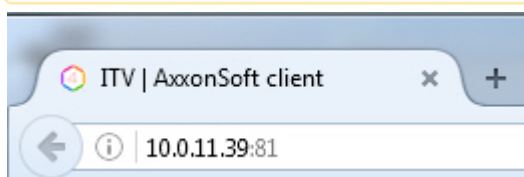

Attention!

If the web server is properly configured (see [Configuring the web server](#)), then a secure HTTPS connection is automatically established.

3. Enter a user name and password for connecting to the Axxon Next web server.

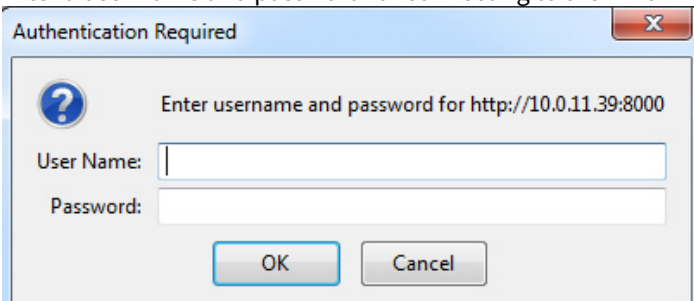
**Attention!**

After 5 successive failed authorization attempts, the user is blocked for 10 minutes.

The web client interface is then displayed.

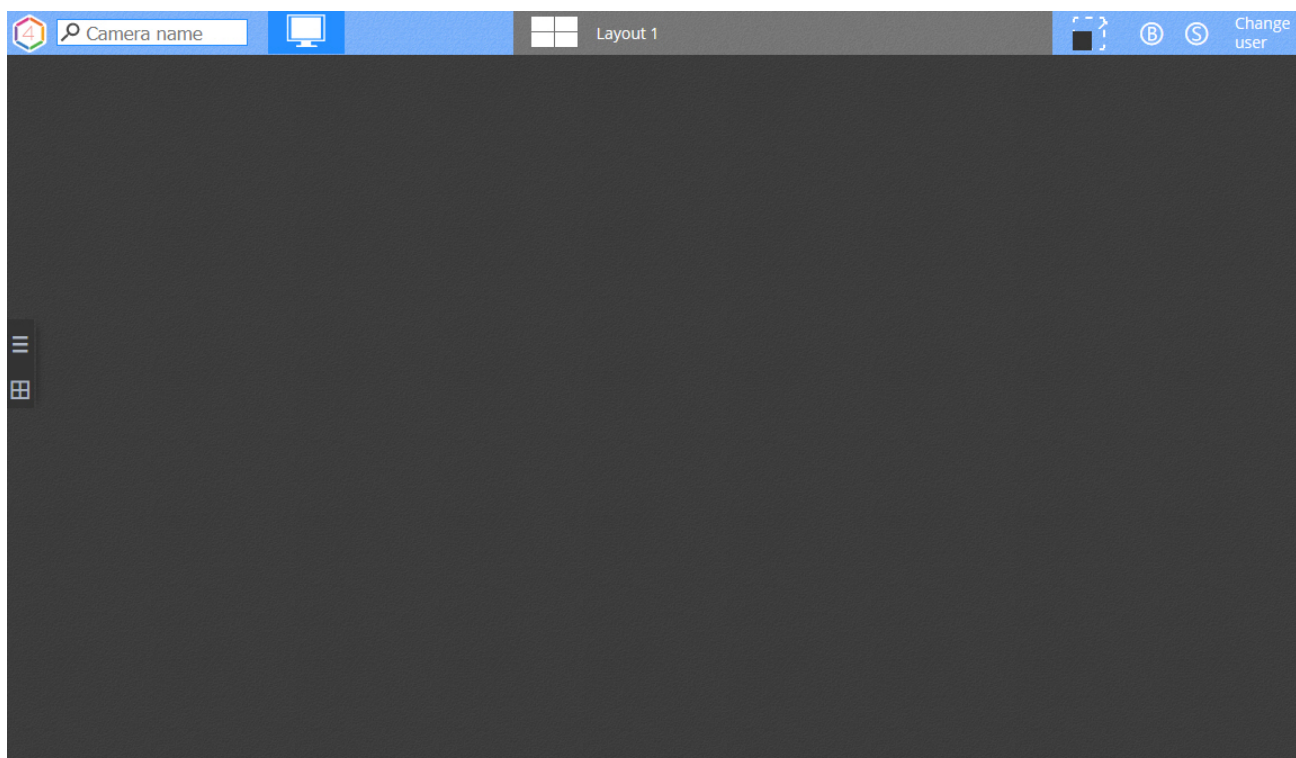

To switch between users, press the **Change User** link in the upper-right corner; another authentication will follow.

Note

The name of the current user is indicated near this point.

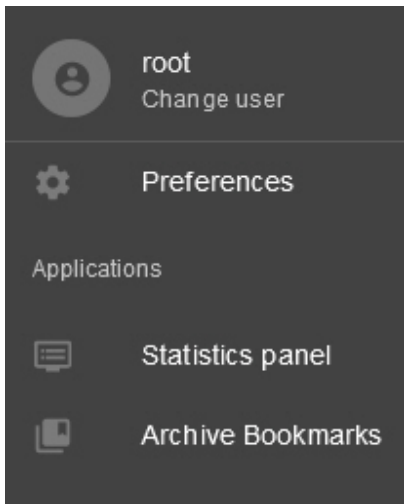

8.11.4 Web client's GUI

The upper panel of a web client contains the following elements:



- camera pane,
- surveillance mode selection buttons,
- available layouts,

Attention!

The web client offers layouts available to each particular user.

You can create and edit layouts using the Axxon Next Client (see [Configuring Layouts](#)).

The number of cameras within a layout is not limited.

- full screen mode button ,
- Additional menu button .

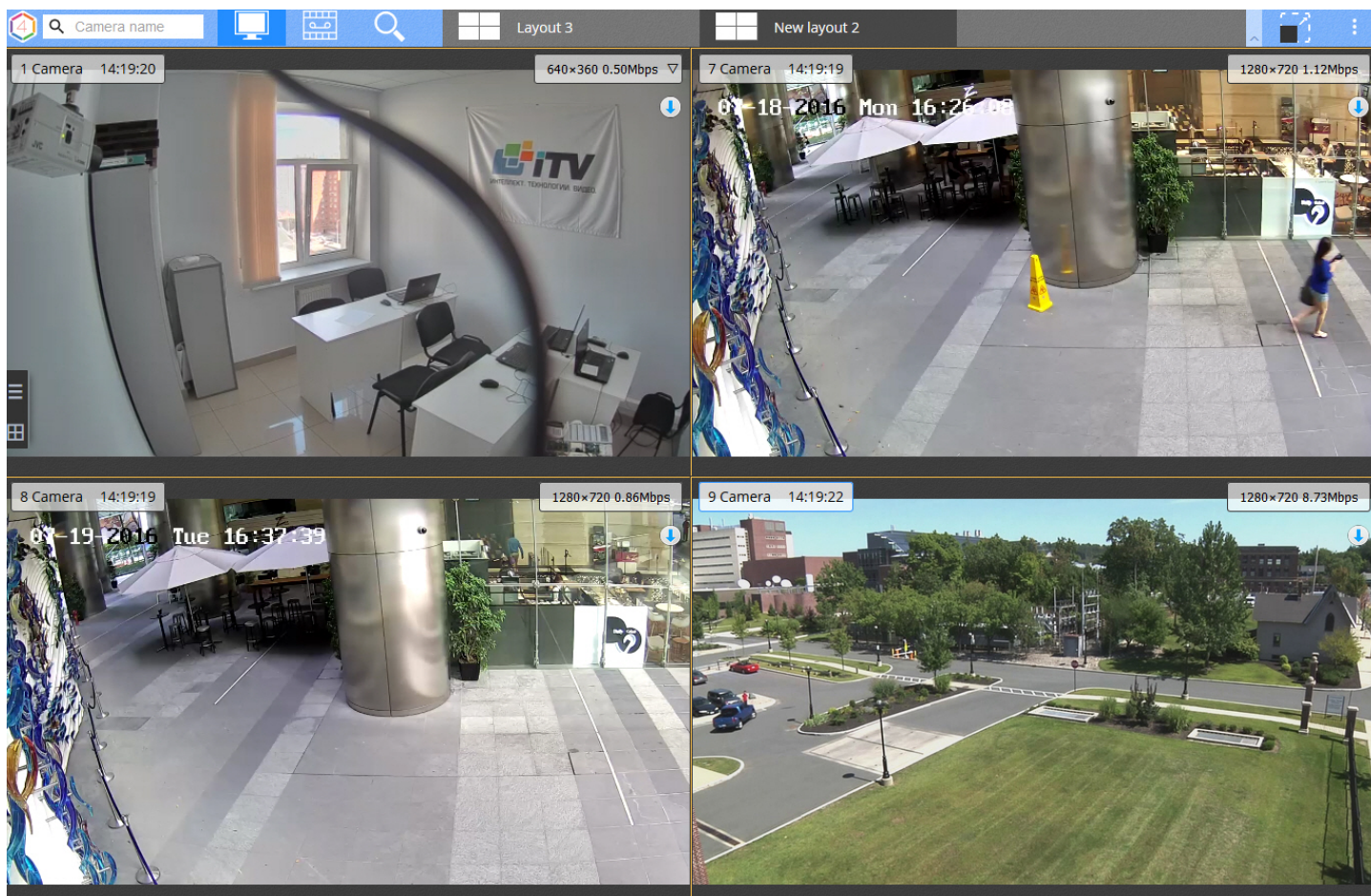

To display the list of available layouts, hover the mouse over the layouts panel.

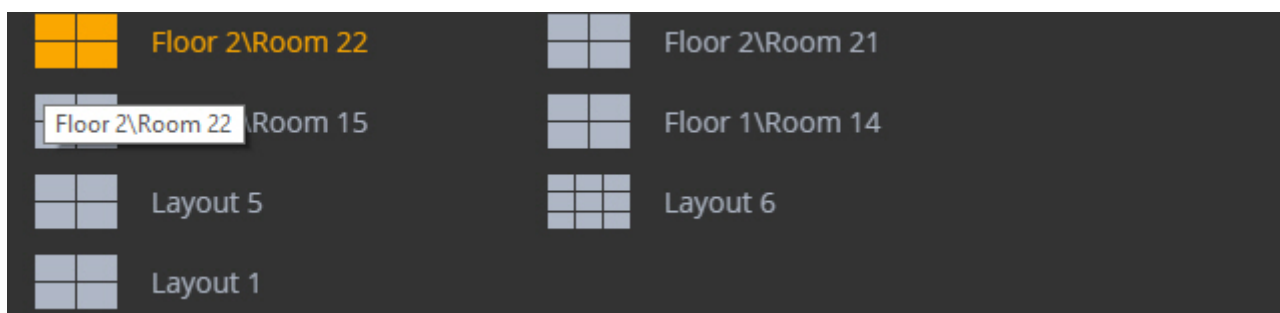

You can also search layouts. To do it, follow the steps below:

1. Hover the mouse cursor over the Layouts panel.
 2. Enter a layout name or its fragment.
- A search bar appears, and the panel displays layouts matching your search criteria.

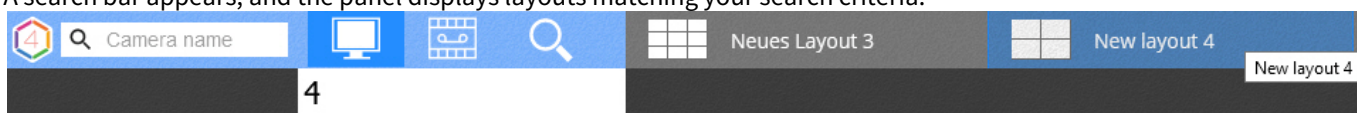

8.11.5 Web Client Configuration

To configure the Web Client, you need to:

1. Click  in the top-right corner and select **Preferences**.

2. By default, switching to another tab or collapsing the browser window stops the transmission of video streams. To preserve the transmission, you can clear the corresponding parameter (1).

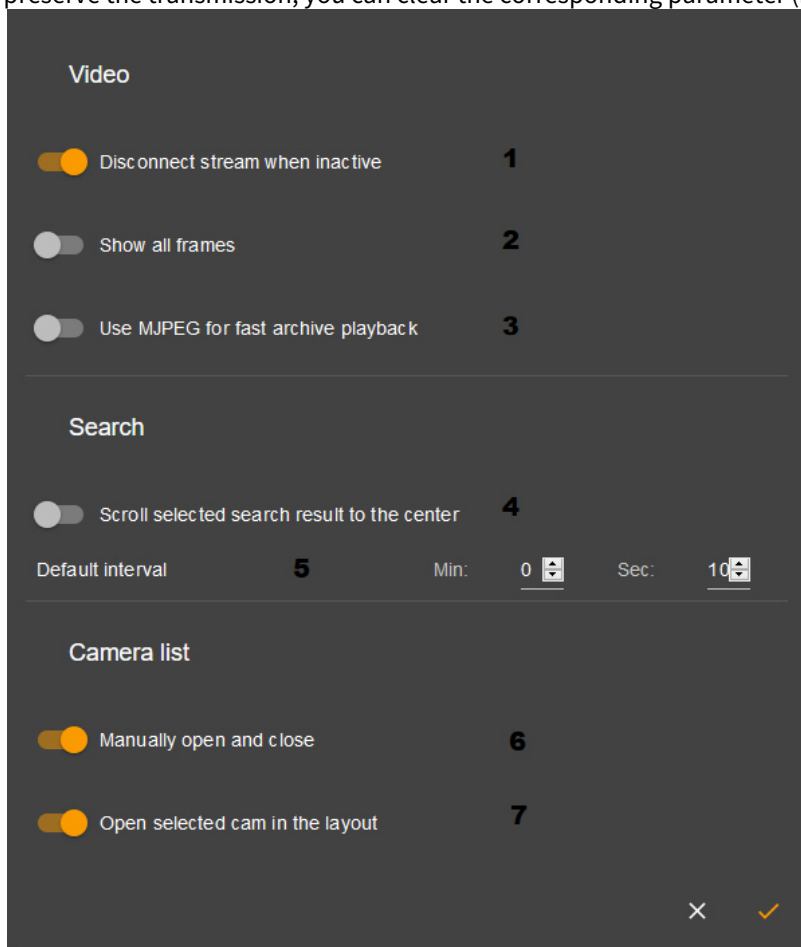

Attention!

This setting is common for all Web Client users in a particular browser.

3. If your layout contains several camera windows, only I-frames (key frames) will be displayed for H.264 cameras by default. Selecting a particular camera sets its window to display all frames. If you need to display all frames in H.264 video regardless of the camera status, activate the **Show all frames** option (2). This setting is common for all Web Client users in a particular browser.
4. By default, fast archive playback uses the H.264 codec. If required, you can use MJPEG codec by setting the **Use MJPEG for fast archive playback** parameter (3). This setting is common for all Web Client users in a particular browser.
5. If you need to position the retrieved video in the center of the screen, activate the **Scroll Selected search result to the center** option (4). This setting is common for all Web Client users in a particular browser.
6. Set the default interval for Time Slice (5, see [Types of Archive search available via the Web Client](#)).
7. By default, the Cameras panel does not hide itself after you select a device. If you need to hide the panel, deselect the **Manually open and close** checkbox (6). This setting is common for all Web Client users in a particular browser.
8. When you select a camera in Cameras Panel, the layout featuring this camera's window opens. If there are several such layouts, then the one with fewer cells is selected. To expand camera view to full screen, disable **Open selected cam in the layout** (7).
9. Click the  button.

8.11.6 Searching for video cameras in the web client

When you start the Web client, the cameras panel opens on the left. It shows a list of all connected devices.

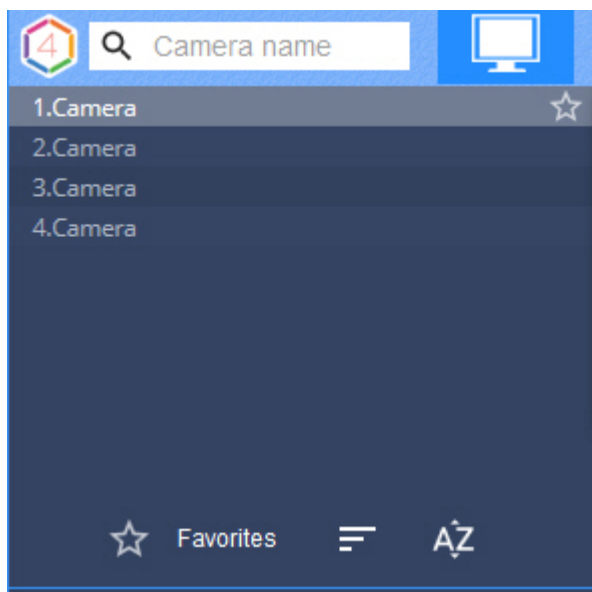

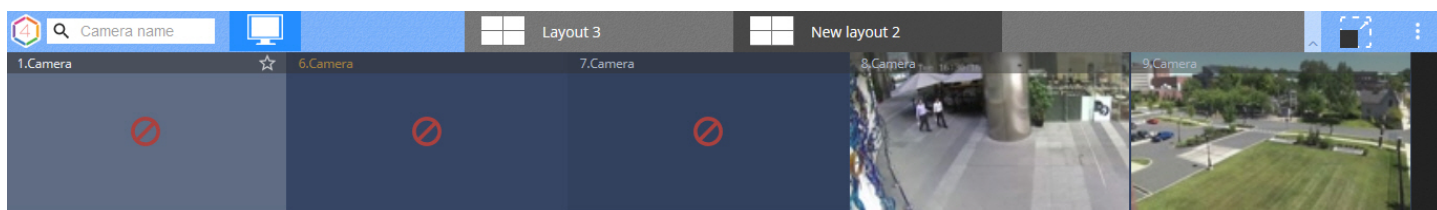

The Cameras panel shows cameras as:

- A list 
- Thumbnails 



By default, the panel includes all available cameras. You can create a list of selected cameras. Do the following:

1. Hover the mouse cursor over the camera icon.
2. Click  to add the camera to the list. The asterisk becomes filled . Another click on the asterisk excludes the camera from the list.

Attention!

The list of selected cameras is common for all web client users in a particular browser.

Click **Favorites** to show selected cameras only. Click the same button once more to show all available cameras.

Additionally, you can bookmark cameras by preparing a list in an Excel file. To do it, follow the steps below:



1. Create an Excel file containing two columns: **id** for camera IDs and **name** for camera names.

	A	B
1	id	name
2	8	Camera1
3	9	Camera2

2. Click  and select the file.

Attention!

After successful loading, only cameras listed in the file will remain bookmarked.

Click  to sort the camera list by ID or  to sort by name.

To search for a camera, enter the full or partial device name in the **Camera name** box.

The Cameras panel will display only the cameras that meet your search criteria. All matching items will be highlighted.

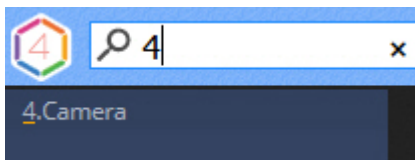

Note

When you add new cameras to your server configuration, they automatically appear in the Web client (no page reloading needed).

To set a group of cameras to be displayed, click the **Default** button and select the required group.

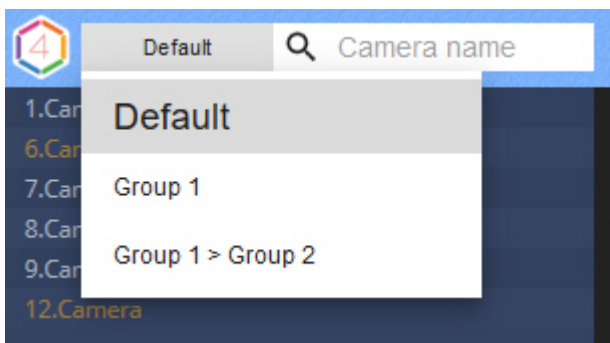

A newly selected camera window displays live video by default.

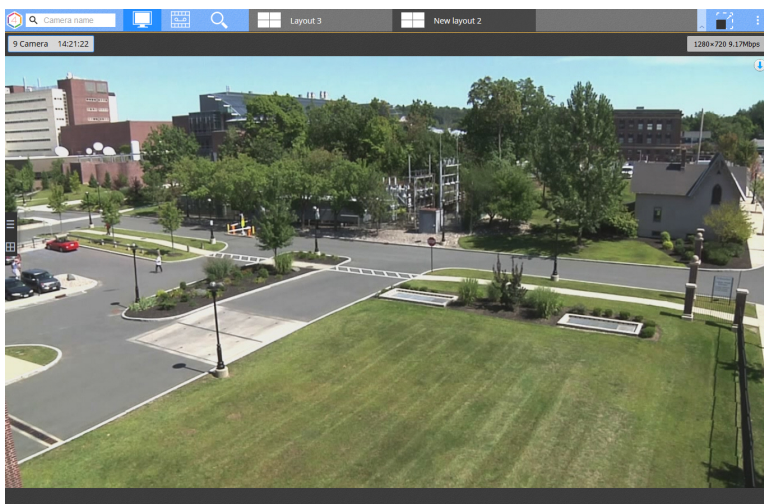

Each camera window upper right corner contains:

- time display (see [Time Display](#) in the main Client);
- video stream parameters;
- footage recording indicator.

8.11.7 Working with layouts in Web Client

8.11.7.1 Summary of how to work with layouts in Web Client

Configuring Layouts

To create and edit layouts in Web Client click  to access the corresponding menu.

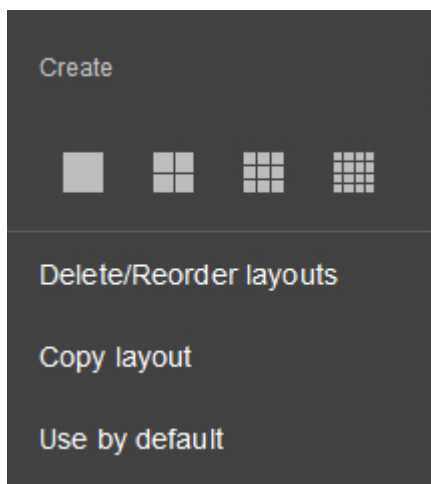

There are a number of things you need to consider when dealing with layouts in Web Client:

1. In Web Client, you cannot edit/share/delete layouts created in the main Client. You can only copy layouts.
2. Layouts created in Web Client will not be available in the main Client.

8.11.7.2 Selecting and searching for a layout

To go to the layout, click it on the panel.

If the panel does not fit all layouts, then to display a list of all available layouts, in the upper right corner click .

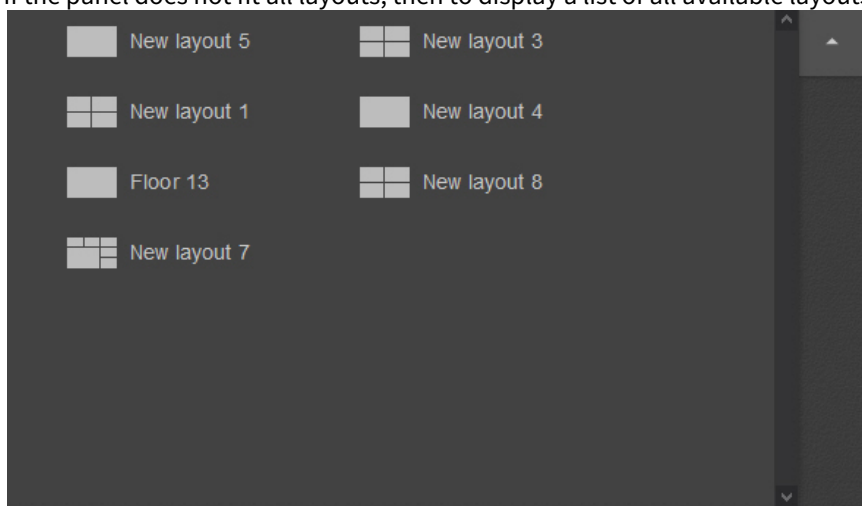

To close the layout list, you need to press a button .

You can also search layouts in the search bar for video cameras. To do this, enter the layout name in part or in full. This will show only those layouts that meet the search conditions.



8.11.7.3 Creating a new layout in Web Client

To create a new layout in Web Client, do as follows:

1. Click  and choose one of the standard layout types.

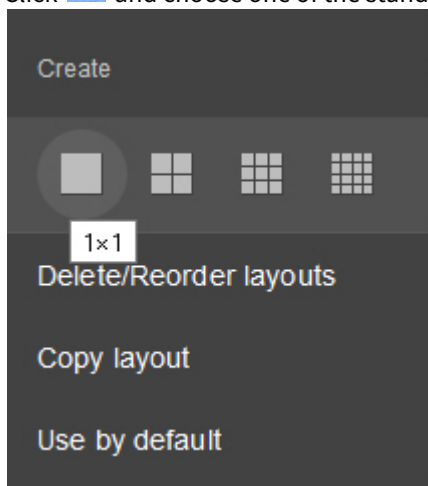

An empty layout will be created.

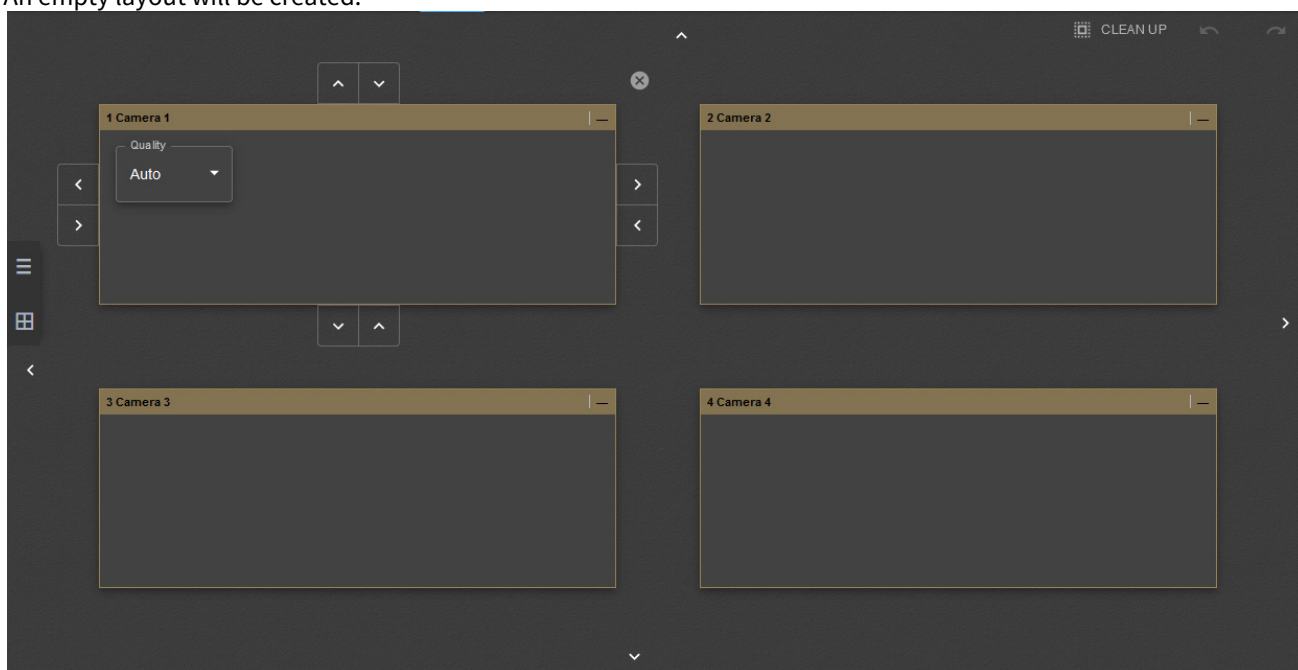

2. You can add new columns or rows of cells using arrows on the layout boundaries (similar to the main Client, see [Adding new cells to a layout](#)).

Note

To delete a column or a row of empty cells, click **Clean Up**.

Note

When editing a layout, the buttons to undo and redo the last action are available .

3. You can resize the cells using arrows on the cell boundaries ((similar to the main Client, see [Resizing cells](#)).
4. Adding video cameras to the cells. To do this, drag & drop a camera from the Cameras panel (see [Searching for video cameras in the web client](#)).
5. Select the default stream for each video camera from the **Quality** list. Use the buttons at the top of the screen to select quality for all camera layouts.

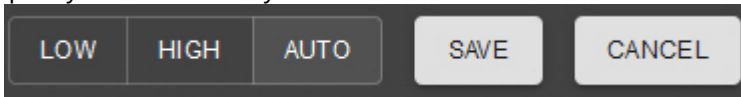

6. Click **Save**.

Note

To undo the layout creation, click **Cancel**.

You have created your layouts.

8.11.7.4 Editing and deleting layouts in Web Client

To edit a layout in Web Client, do as follows:

1. Select the layout.
2. Click  and select **Edit Layout**.
3. Make changes.
4. Click **Save**.



To rename a layout, do as follows:

1. Double left-click and enter a new name.
2. Click **Save**.

To rearrange the layouts, do as follows:

1. Click  and select **Delete/Reorder Layouts**.
2. Drag & drop layouts wherever you want.
3. Click **Save**.

To delete a layout, do as follows:

1. Click  and select **Delete/Reorder Layouts**.
2. Click to the right of the layout .

8.11.7.5 Selecting the default layout in Web Client

You can select the individual default layout for each user to be displayed after they launch Web Client.

If you don't set this layout, they'll see a blank screen.

To set the default layout, do as follows:

1. Go to the desired layout.

- Click  and select **Use by Default**.

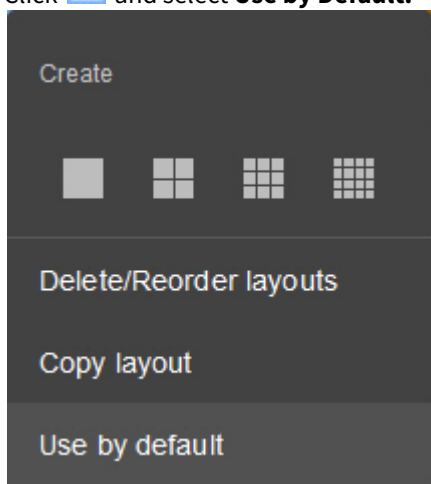

After that, the layout icon will look like this:

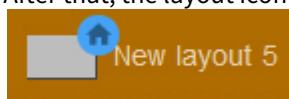

To remove the default layout, click  and select **Do not use by default**.

8.11.7.6 Copying layouts in Web Client

Layout copying

To copy a layout in Web Client, do as follows:

- Select the layout.
- Click  and select **Copy Layout**.

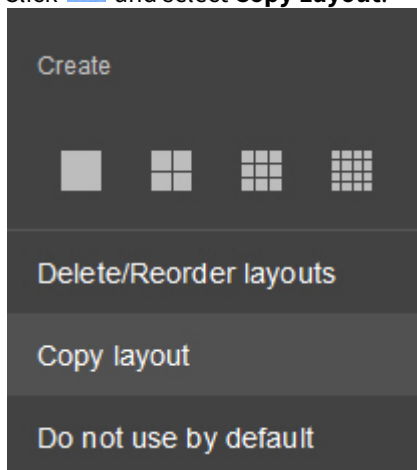



- You can make changes to the layout.
- Click **Save**.

8.11.7.7 Sharing layouts in Web Client

Share Layouts

To share a layout in Web Client, do as follows:

1. Select the layout.
2. Click  and select **Edit Layout**.
3. Click  and in **Share With**, select one or several target roles to share layout with.
4. Click **Save**.

Shared layouts are sealed with the following sign:

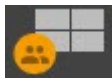

8.11.8 Real-time video surveillance via the web client

To view a video, you have to select either a camera from a panel, or one of available layouts (see [Searching for video cameras in the web client](#)).

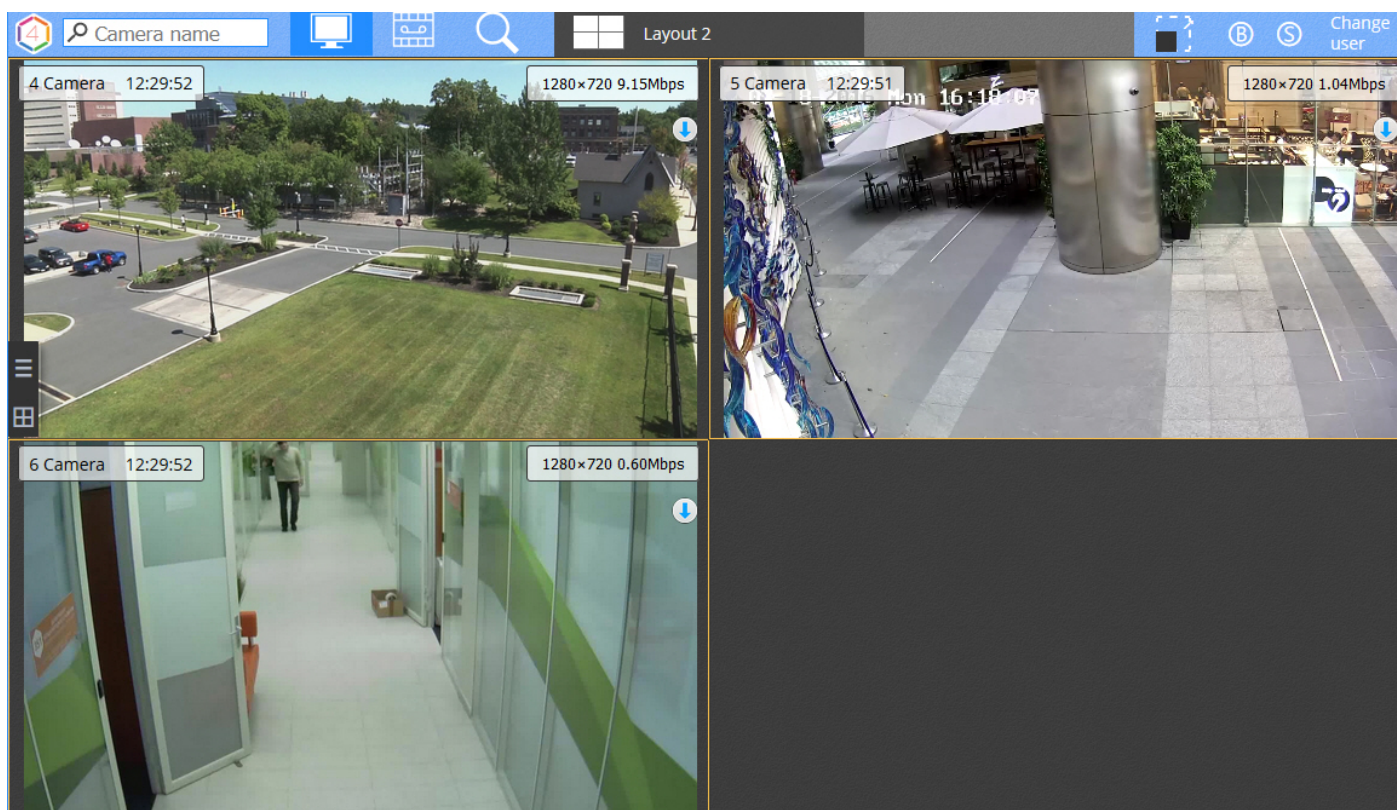

The Web Client supports playback of the following video formats: MJPEG, H.264, H.265. Any other formats are re-coded to MJPEG by the Server.

Attention!

H.265 playback is possible only in the Edge browser with hardware acceleration.

You can play back a video in the web client with any of the 2 players: jpeg and mp4. If your browser supports mp4 format, the mp4 player is used. Otherwise, your videos will be played back via the jpeg player.

Attention!

If your layout contains several camera windows, only I-frames (key frames) may be displayed in H.264 streams, depending on settings (see [Web Client Configuration](#)). For the selected camera, each frame is displayed.

In MPEG videos, each frame is displayed.

Note

When you use Internet Explorer to toggle frames reception mode between 'I-frames only' and 'each frame' in the camera window, short video dropouts may occur. In such a case, other browsers will show the most recent I-frame.



If your camera is capable of multi-streaming, the lowest resolution stream will be displayed by default.

To select a stream in the web client, do as follows:

1. Click the parameters of the current stream.
2. Select a stream to be displayed.

Note

Video stream settings are not memorized while switching between layouts.

Click  or double click the image for full screen view. To exit full screen mode, click again the  button, or press **Esc**.

8.11.9 Controlling PTZ cameras through the web client

A PTZ video camera is controlled through the PTZ device control panel.

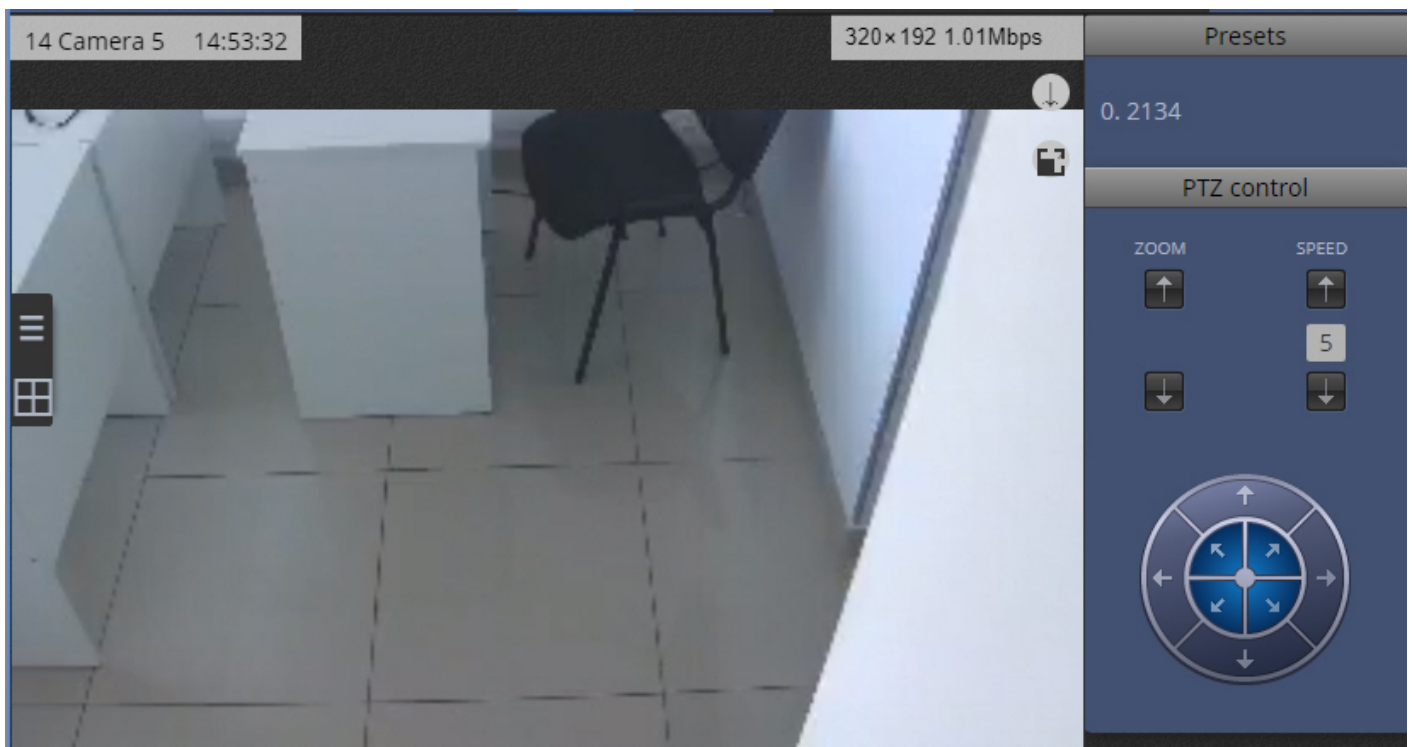

The following actions can be performed using the PTZ device control panel:

1. Use presets.
2. Adjust optical zoom and positioning speed of the video camera.
3. Modify the horizontal and vertical tilt angle of the video camera.

8.11.9.1 Controlling a PTZ camera through the web client by using presets

To go to a preset, select the relevant line in the list of presets.



8.11.9.2 Changing the optical zoom of a PTZ camera in the web client

To change the optical zoom of a PTZ unit, use the buttons in the **zoom** group.



 – increase image

 – reduce image

 – field for displaying speed at which the camera changes the zoom scale

8.11.9.3 Changing the positioning speed of a PTZ camera in the web client

To change the positioning speed of a PTZ camera, use the buttons in the **Speed** group.



 – increase positioning speed

 – reduce positioning speed

 – field displaying the current positioning speed

8.11.9.4 Changing the tilt of a PTZ camera in the web client

To change the tilt of a PTZ camera, use the arrows in the **PTZ Control** group.



The arrow direction indicates the direction in which the camera lens will be moved when the arrow is clicked.

8.11.10 Viewing video archives through the web client

To view a camera's Archive, do as follows:

1. Pick a camera on the camera panel or on the layout.
2. Click the



button.

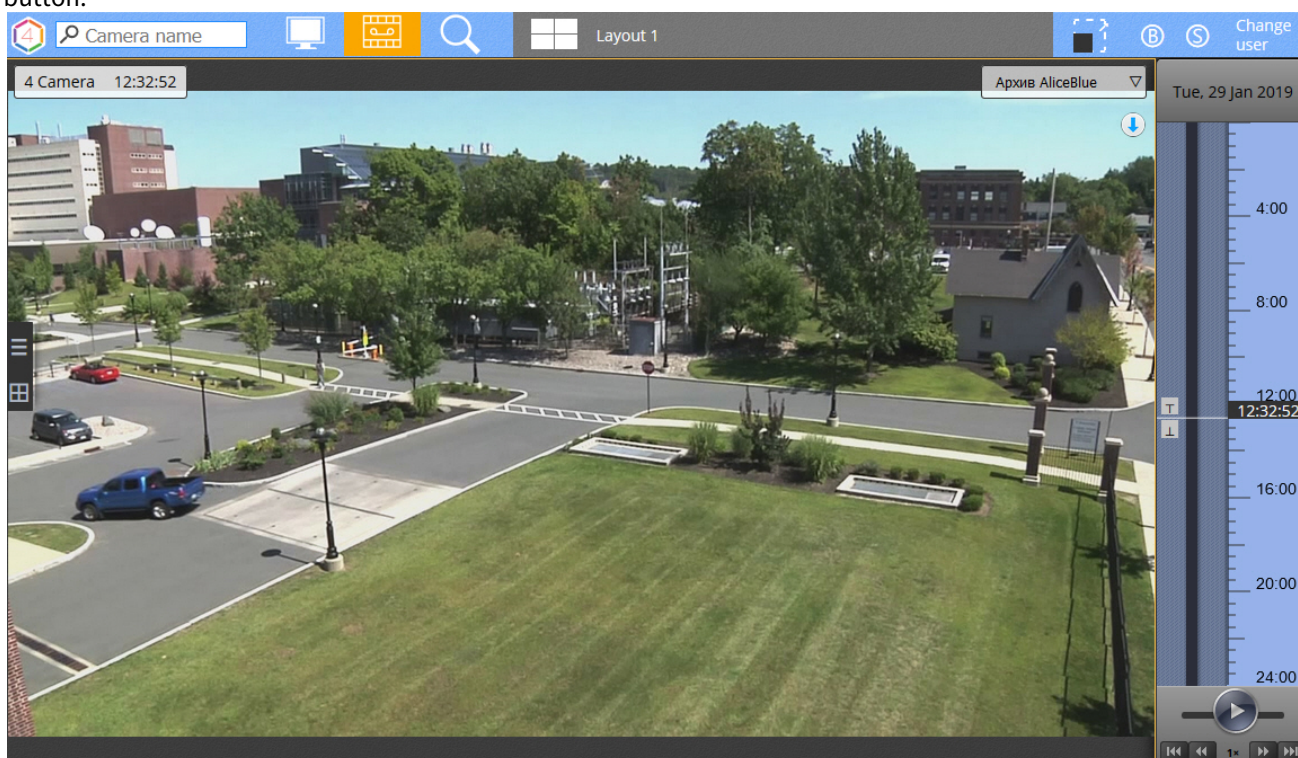

Note

Video Footage opened by default is specified as Default Archive in settings (see [Binding a camera to an archive](#)).

3. The archive navigation panel is then displayed, with the following interface features:
 - a. Timeline. Archive navigation via the timeline in the web client is the same as when working in the Axon Next client (see [Navigating Using the Timeline](#)).

Attention!

You cannot resize the timeline in the web client. By default, the timeline displays the current date's recordings. You can switch to another date using the position selection panel (see 3c).

Note

Similarly to the regular Client (see [The Timeline](#)), alarms are indicated on the timeline as flags, and comments as icons.

- b. Playback control panel. Archive navigation via the playback panel in the web client is the same as when working in the Axxon Next client (see [Navigating Using the Playback Panel](#)).

Attention!

Fast reverse playback in H.264 format will be not smooth because of the use of I-frames.

- c. Archive position selection panel. The archive position selection panel is opened by left-clicking the date above the timeline.
4. To select an Archive, do as follows:
- a. click the name of the current Archive;



- b. pick the Archive of interest.



8.11.11 Archive position selection panel for the web client

To choose a time position in the archive by using the archive position selection panel:

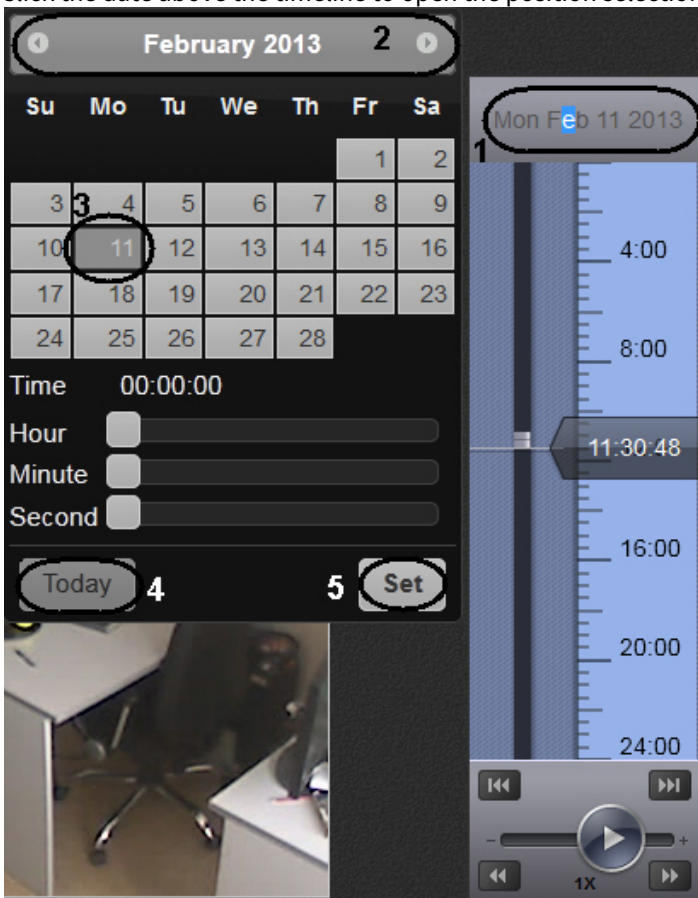
1. Click the date above the timeline to open the position selection panel (1).



2. To set the playback position to the current time and date, click the **Today** button and go to step 6 (4).

- Use the  and  buttons to select a month (2).
- Click the necessary date on the calendar to select a day (3).

Note

The days, for which there is video footage are in light shade.

- Use the **Hours**, **Minutes**, and **Seconds** sliders to set the time.



- To set the playback position, click the **Set** button (5).

The time position in the archive is now chosen.

8.11.12 Archive search through the web client

You can perform searches in Video Footage from the web client. To initiate a search, do the following:

- Pick a camera on the camera panel or layout.

- Click the  button.

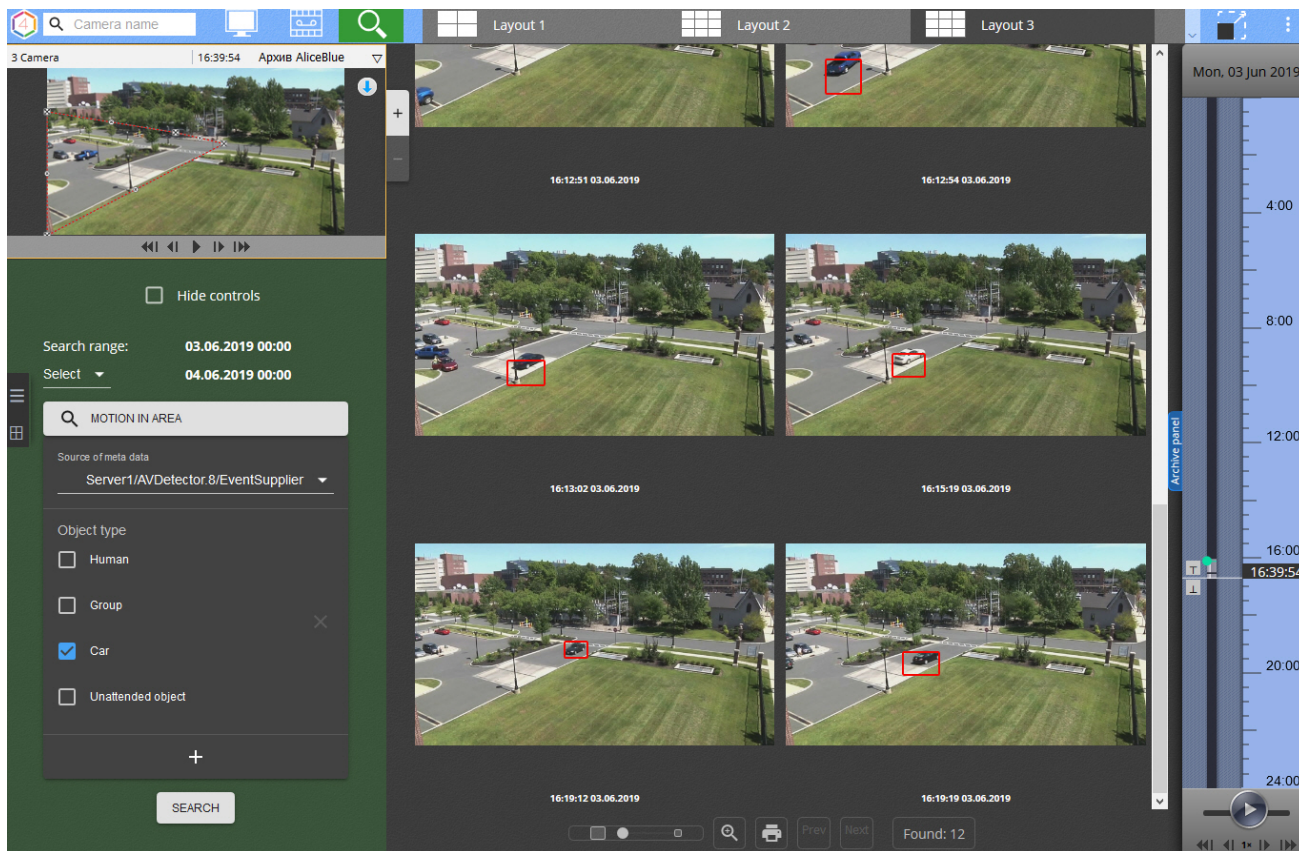

You can resize camera windows with  buttons.

Attention!

If you select an item from Cameras panel, the search conditions will not be reset (see [Searching for video cameras in the web client](#)).

If a search was run more than once, and the user did not exit Archive Search mode during that time, it is possible to switch between search results.



8.11.12.1 Types of Archive search available via the Web Client

The web client interface offers the following types of search:

1. Motion in an area
2. Line crossing.
3. Motion between areas.
4. Large Number of Objects detection tool.
5. Loitering.
6. Face search.

Attention!

You can load only JPEG images.

7. LPN search.
8. TimeSlice.

Note

The default interval is set in the Web client's settings (see [Web Client Configuration](#)).

9. Events search.

Archive search interface and search parameters pane are identical to those in the standalone Client software (see [Video surveillance in Archive Search mode](#)).

You can also build a Heat Map with the Web Client (see [Building a Heat Map](#)).

8.11.12.2 Building a Heat Map

Attention!

To build a Heat Map, you need at least one source of metadata (for example, an Object Tracker).

Heat Maps are useful for evaluation of motion intensity within the scene and determining common trajectories of moving objects.

How to build a Heat Map:

1. Proceed to the Archive search.

2. Specify time period to build the Heat Map for (1).

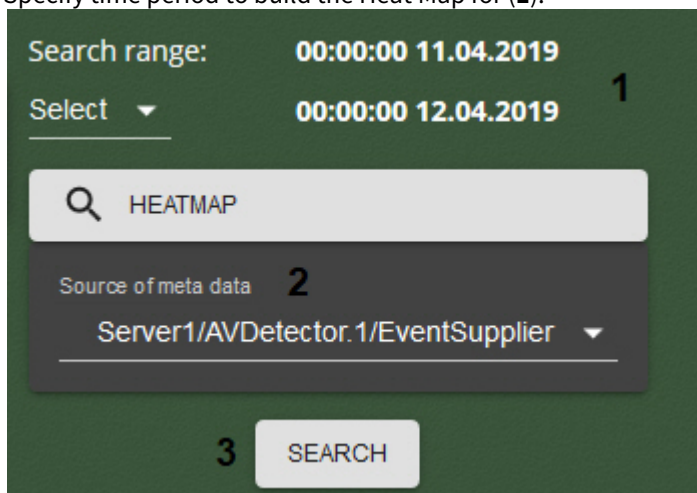

3. Click the + button and select **Heat Map**.

4. Select the source of metadata (2).

5. Click the **Search** button (3).

The Heat Map appears in the search results window.

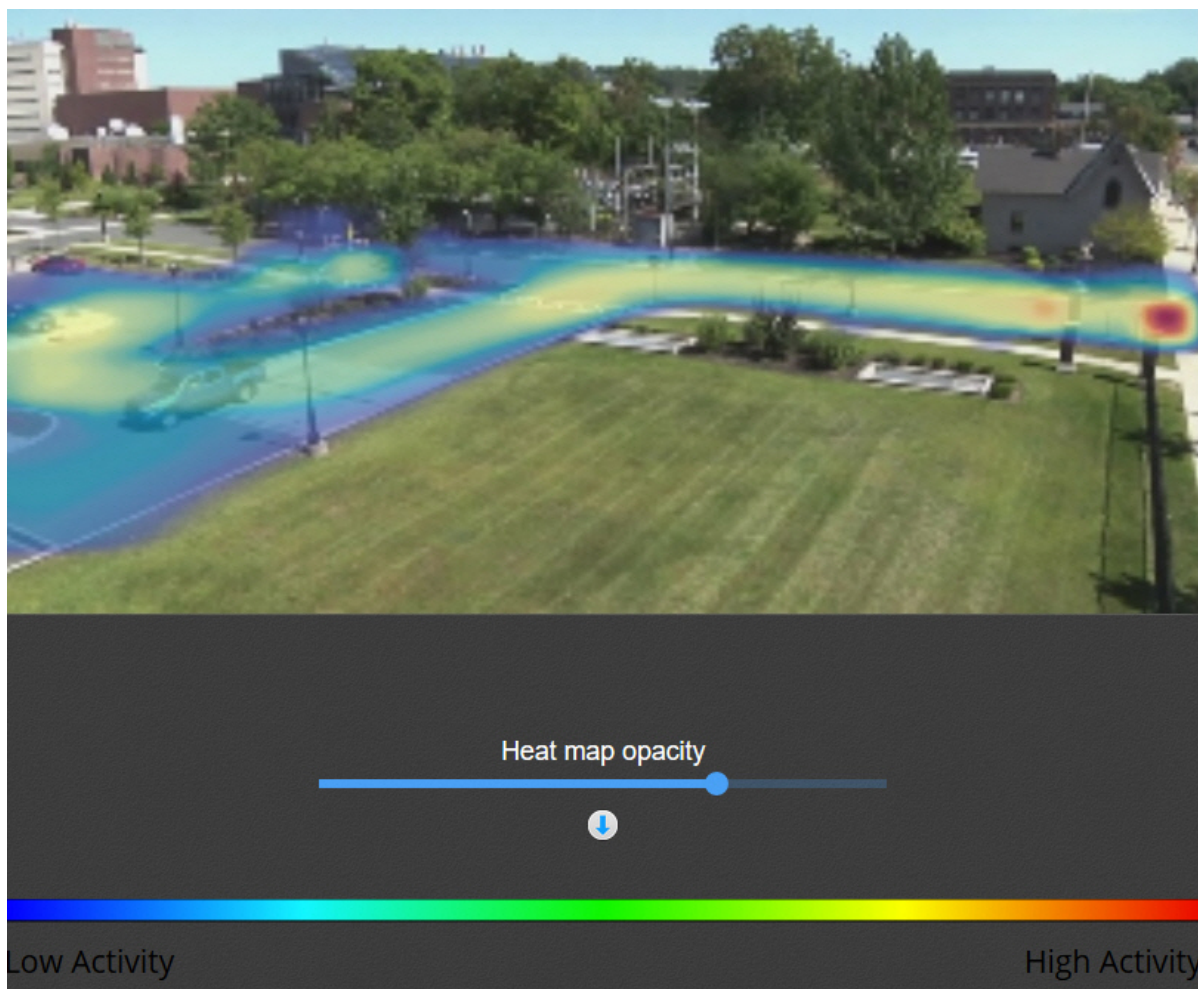

Use the dedicated slider to adjust the transparency of the heat map.

Click  to download the heat map.

You can build a report based on the received data.

8.11.12.3 Simultaneous search in multiple camera Video Footage via the web Client

You can use the Web Client for multiple camera Video Footage searching by:

- facial recognition events;
- ANPR events;
- detection tool triggering events;
- TimeSlice.

To simultaneously search multiple cameras' Video Footage, do the following:

1. Proceed to the Video Footage search (see [Archive search through the web client](#)).
2. Set the search criteria.
3. Open Cameras panel and select the required devices (see [Searching for video cameras in the web client](#)).

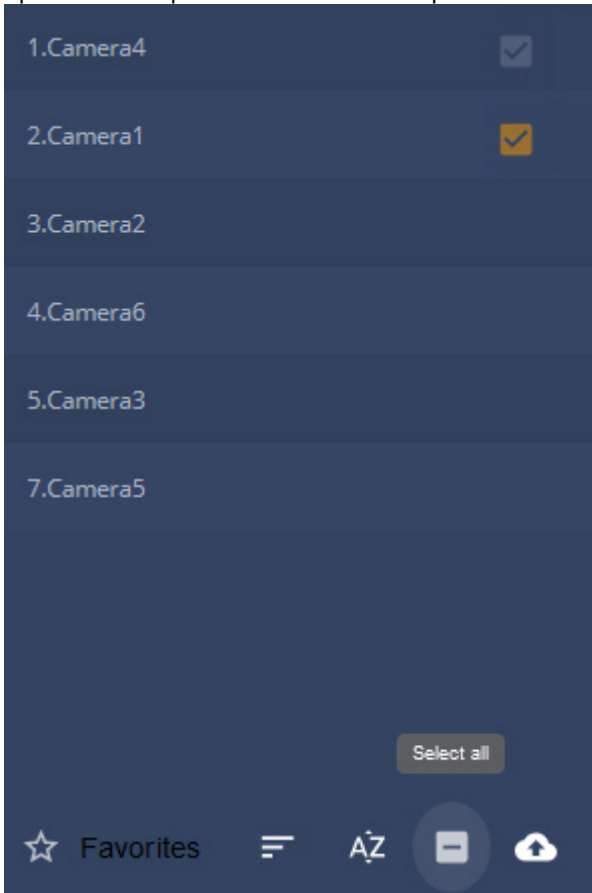

Note

To select all cameras, select the appropriate box on the bottom of the page.

4. Click the **Search** button.

8.11.12.4 Reporting the search results

The Web Client also includes the [Stimulsoft](#) report editor for building reports on retrieved video fragments.

To build a report after you finished searching, click  in the bottom part of the screen.

Attention!

The report is limited to first 60 retrieved videos.

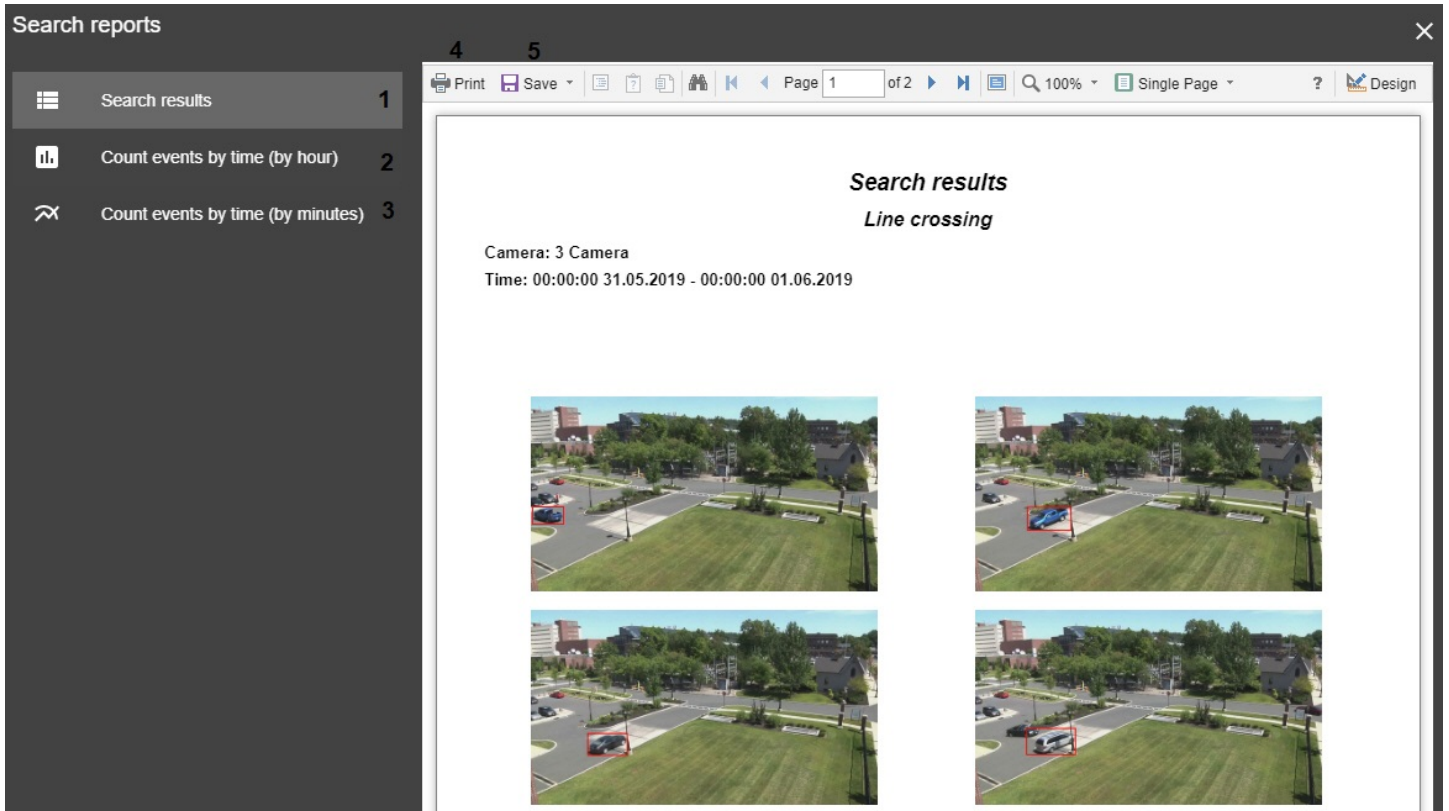

There are 3 types of reports available:

1. Retrieved fragments (1).
2. Retrieved fragments (number / per hour) (2).
3. Retrieved fragments (number / per minute) (3).

Click **Print (4)** to hardcopy a report, or **Save (5)** to export into an appropriate format.

8.11.13 Alarm Monitoring via the Web Client

You can use the Web client to monitor active alarms across the entire Axxon domain.

To make the web client display active alarms, select any camera or layout (see [Searching for video cameras in the web client, Web client's GUI](#)).

Note

You cannot monitor alarms that went off before you selected the camera/layout.

When an alarm goes off, an alarm panel appears (like in the standalone client software, see [Alarms Panel](#)).

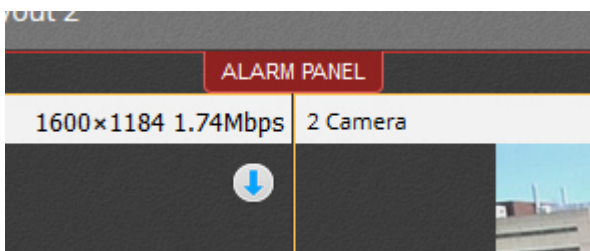

Click **Alarm Panel** to open the panel.

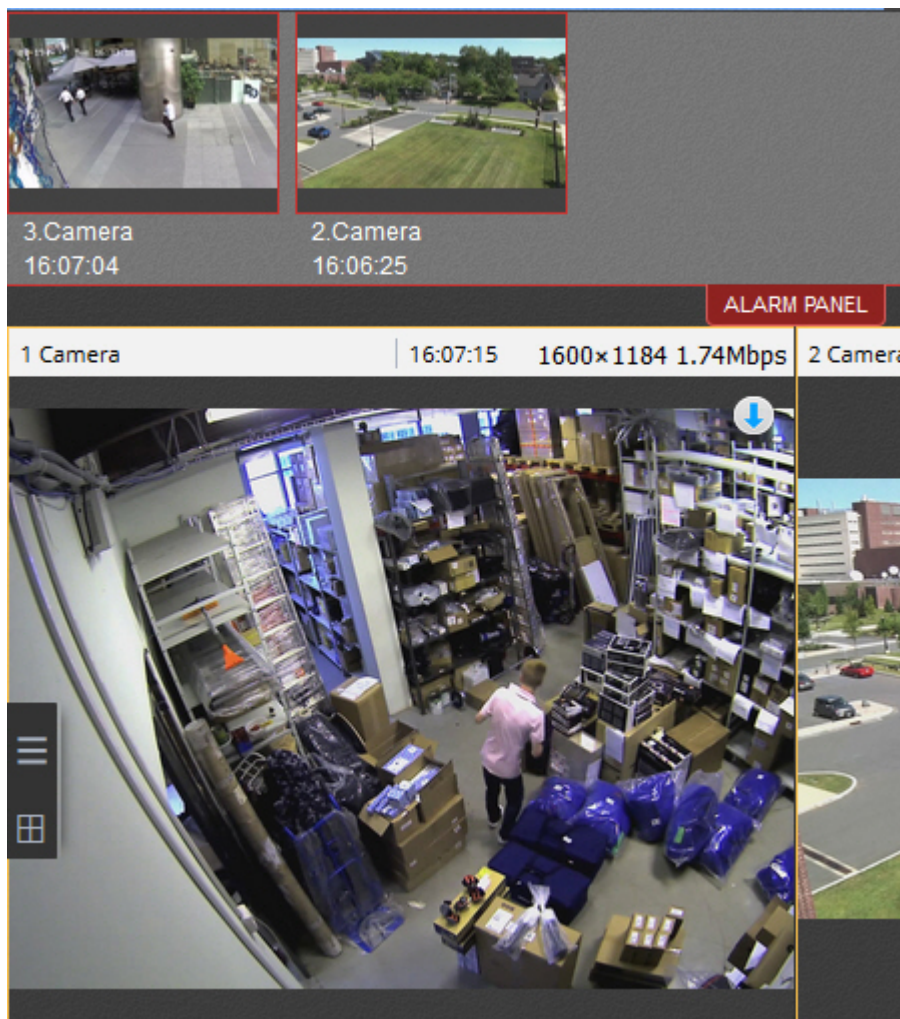

The system will now switch to Archive (video footage) viewing mode and show the video of the selected event.

8.11.14 Listening to a camera's microphone via the web client

Attention!

You can play back audio in mp4 format only.

To listen to a camera's microphone, click the



button in the camera window.

Note

Audio playback in web browsers is supported in Windows 8 and higher OS versions.

After you complete this action, a volume slider appears.

**Note**

You cannot play back audio from multiple cameras simultaneously.

The higher is the slider position, the higher is the volume.

To mute audio, click the



button.

8.11.15 Digital video zoom in the web client

Digital zoom of video occurs in a viewing tile during viewing of live video as well as when viewing archive video. To increase the zoom level, use the mouse scroll wheel.

The image cannot be made smaller than the source size. The maximum video zoom is 16x.

To select the viewed portion of the frame at a changed scale, drag the mouse outside of the video viewing area.



Note

For PTZ units, you can zoom in by using the buttons in the **zoom** group

8.11.16 Export in Web Client

To export a snapshot / frame, click the  button while viewing video. A JPG file will be exported to a folder specified in the Server settings.

To export video, do as follows:

1. Switch to Archive mode (see [Viewing video archives through the web client](#)).
2. On the timeline, set the timeline indicator to the location that matches the beginning of the export interval. Click the  button. Set the indicator to the location that matches the end of the export interval. Click the  button.
3. Click the  button.

Note

To delete the export interval click the  button.

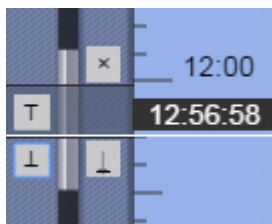

4. Select the video format (1). You can export videos to avi, mkv, mp4 and exe formats.

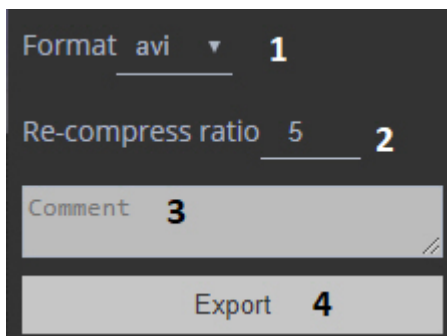

- 5. If you are exporting a video in .avi format, select the compression level (2).
 4 – minimum compression, maximum file size;
 6 – maximum compression, minimum file size.
- 6. If necessary, add comments for the export (3). The comments will be shown as captions when the exported video is played.
- 7. Click the **Export** button (4).

The progress bar is displayed on the drop-down panel as in the Client (see [Viewing export progress](#)).



When the export is complete, the panel color changes to green.



To download an exported file, click its name on the panel.

8.11.17 Viewing Camera and Archive Statistics

To view camera statistics, click  in the top right corner, and select **Statistics Panel**.

Video-streams statistics for all cameras											
CAMERAS						ARCHIVES					
Host	Name	Resolution	FPS	Bitrate(Mbps)	Format	Warn	Resolution	FPS	Bitrate(Mbps)	Format	Warn
Server1				15.40					12.29		
	1 Camera	1600x1184	19.43	1.75	MPG4	✓					
	2 Camera	1280x720	30.04	9.88	MPG4	!	1280x720	30.05	9.88	MPG4	!
	3 Camera	1280x720	25.00	0.94	H264	⚠	1280x720	25.00	0.94	H264	⚠
	4 Camera	1920x1080	24.89	2.83	H264	⚠	1920x1080	25.05	1.47	H264	✓

Note

Loading statistics from large number of cameras may take some time. The loading process is visualized by a progress indicator.

On the **Cameras** tab, the following parameters are displayed for each video stream of each camera:

- resolution;
- frame rate;
- bit rate;
- compression format.

If the bitrate exceeds the expected value, and there is more than 1Mbit per megapixel, the stream is marked with "



".

If the bitrate exceeds the expected value, and there is more than 2Mbit per megapixel, the stream is marked with "



".

On the **Archives** tab, the following information is displayed for each Archive:

Video-streams statistics for all cameras			
CAMERAS		ARCHIVES	
Host	Archive	Number of Cameras	Total Bitrate(Mbps)
Server1	AliceBlue	4	14.40

- name;
- number of linked cameras;
- cumulative bit rate of linked cameras.

Note

The indicator in the upper right corner displays the AxxonNext Web Client and Server version numbers.

To return to the previous page, click **Back** in the left upper corner of the screen.

8.11.18 Working with bookmarks in the Web Client

A bookmark represents either a comment to Video Footage (see [Operator comments](#)), or a protected video (see [Protecting video footage from FIFO overwriting](#)).

To work with bookmarks, click the  button in the top right corner of the Web client window, and select the **Archive Bookmarks** option.

Select	Begins	Ends	Created ↓	Created by	Protected	Name	Comment	Video
<input type="checkbox"/>	21.03.2019 14:43:01	21.03.2019 14:59:19	21.03.2019 16:15:37	root	<input checked="" type="checkbox"/>	Camera	Protected video 1	
<input type="checkbox"/>	21.03.2019 14:01:16	21.03.2019 14:01:16	21.03.2019 16:04:44	root	<input type="checkbox"/>	Camera	Comment 1	
<input type="checkbox"/>	21.03.2019 14:13:55	21.03.2019 14:23:37	21.03.2019 16:04:50	root	<input type="checkbox"/>	Camera	Comment 2	
<input checked="" type="checkbox"/>	21.03.2019 14:01:16	21.03.2019 14:22:04	21.03.2019 15:49:54	root	<input checked="" type="checkbox"/>	Camera	Protected video 2	

Attention!

You can access only the bookmarks on the visible part of the footage archive (see [Configuring access restrictions to older footage](#)).

The system does not display bookmarks related to currently re-recorded part of the archive.

You can:

1. Edit a bookmark.
2. Delete a bookmark.
3. Un-protect a protected video.
4. Delete a protected video.

Use the search bar to locate a necessary bookmark.



To proceed to a particular video, click the button in the **Video** column.

Click **Back** to return to the main page.

8.11.18.1 Editing a bookmark

To edit a bookmark, do as follows:

1. Select the required bookmark from the list.
2. Click the **Edit bookmark button**.

Begins
2019-03-21 14:01:16

Ends
2019-03-21 14:22:04

Comment
Protected video 2

3. If necessary, you can alter the time interval and/or a text comment.
4. Click **Save Bookmark**.

8.11.18.2 Deleting a bookmark

To delete a bookmark, select it from the list and click **Delete Bookmark**.

Hold Ctrl key to select multiple bookmarks.

8.11.18.3 Un-protecting a video

To un-protect a video, clear the **Protected** checkbox beside the bookmark.

8.11.18.4 Deleting a protected video

To delete a protected video, select a protected bookmark and click the **Delete Video** button.

8.12 Working with Axxon Next Through the Mobile Clients

Axxon Next clients are available on the iOS, Android and Windows Mobile operating systems.

For more information on configuring and using the mobile client apps, refer to the [corresponding documentation](#).

9 Description of utilities

9.1 Axxon Next Tray Tool

The *Axxon Next Tray Tool* launches automatically during system startup and displays an icon in the Microsoft Windows taskbar notification area.

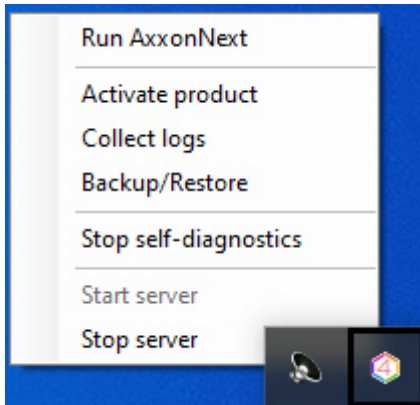

Note.

The executable TrayTool.exe is located at <Axxon Next installation folder>\AxxonNext\bin.

With the *Axxon Next Tray Tool* utility, you can quickly start the following applications from the notification area:

- Client,
- Activation Utility,
- Axxon Support Tool,
- Configuration Backup and Restore utility,
- Self-checking Service,
- Server rebooting.

9.2 Activation Utility

License activation for the Axxon Next software package is carried out through the product activation utility.

The activation utility is accessible at **Start -> All Programs -> Axxon Next -> Utilities -> Program Activation**, or from the tray menu (see the [Axxon Next Tray Tool](#) section).

Note

The product activation utility program file LicenseTool.exe is located in the folder <Directory where Axxon Next is installed>\AxxonSoft\AxxonSmart\bin\

Then you must select the name of one of the Axxon Domain servers to which the license file will be applied (the file is applied to all Axxon Domain servers launched at the moment of activation) and connect to the system, under an administrator's user name and password, to continue the activation process.



Activation utility

User authentication
Choose Server to connect and enter administrator's username and password

Server name or IP address: V-BELYAKOV

Username: root

Password: ****

Next >>

When the utility has loaded, its main will be displayed.

Note

To activate Axxon Next, connect to a Server in the Axxon domain. Otherwise, an error message appears.

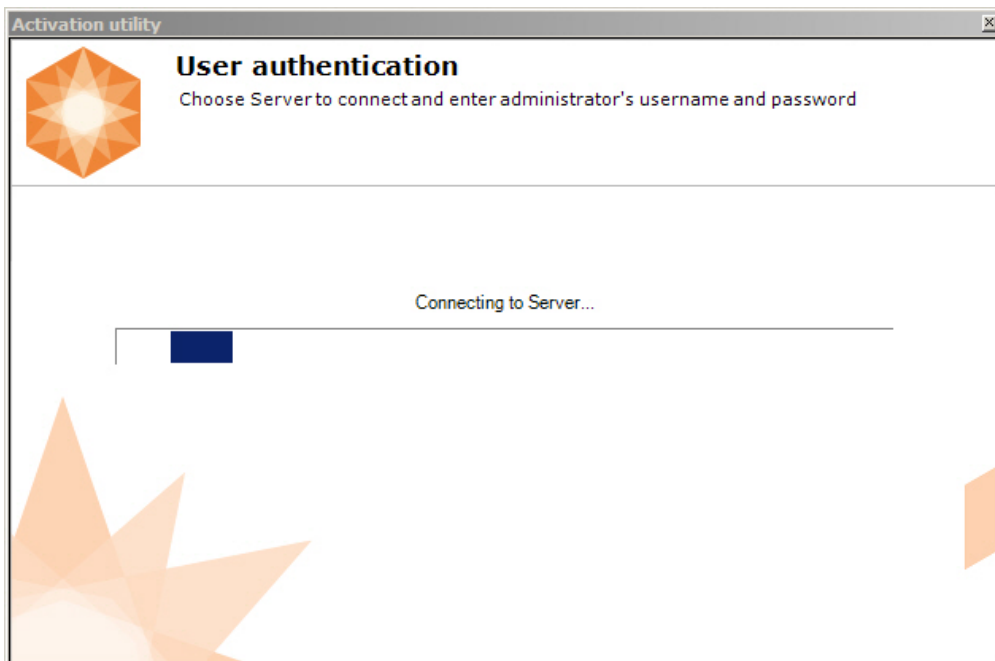

Activation utility

User authentication
Choose Server to connect and enter administrator's username and password

Connecting to Server...

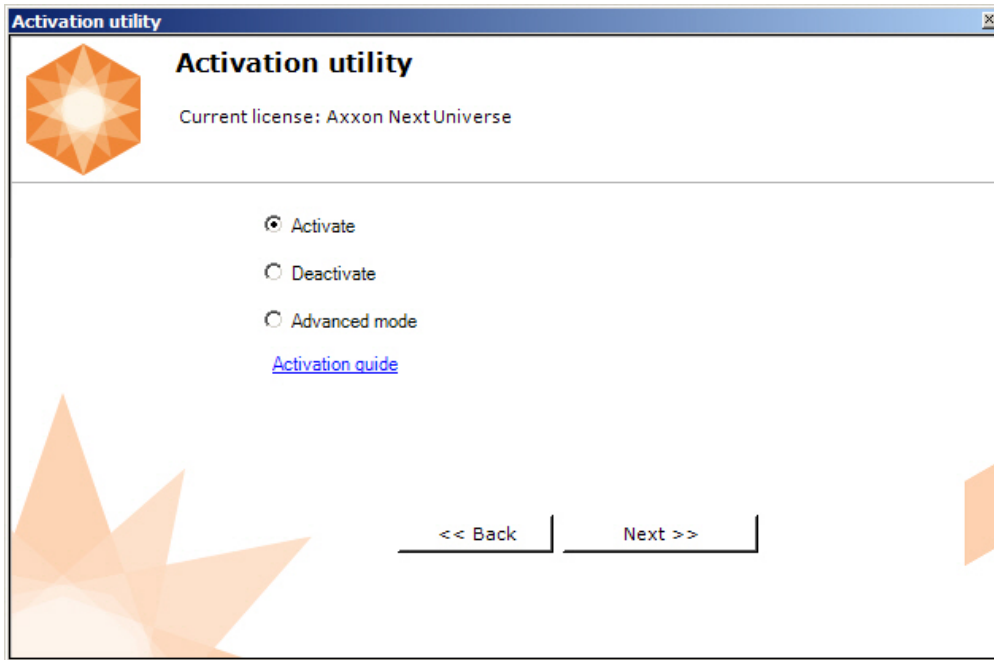

To activate Axxon Next, please refer to the document titled [Activation Guide](#), which presents step-by-step instructions on activating, updating and upgrading Axxon Next .

It is also recommended that you use the prompts displayed in the product activation utility's dialog boxes.

9.3 Axxon Support Tool

9.3.1 Purpose of the Support.exe Utility

The Support.exe utility is designed to collect information about the configuration and operating status of hardware, the Windows operating system, and the Axxon Next software. The utility generates an archive that can be used by the company's technical support department. In case of malfunctions or errors in the Axxon Next software package, please visit our technical support server at <https://support.axxonsoft.com/> and compose a message containing a description of the problem and attach the archive that was generated by the Support.exe utility.

9.3.2 Launching and Closing the Utility

The Support.exe utility is launched using the **Start** menu, which is intended for launching user programs in Windows. Go to **Start** → **All Programs** → **Axxon Next** → **Gathering system information**.

Note

The Support.exe utility is located in the folder <Axxon Next installation directory>\AxxonNext\Support

Note

The Support.exe utility requires administrator rights to run.

The Support.exe utility dialog box will then be displayed.

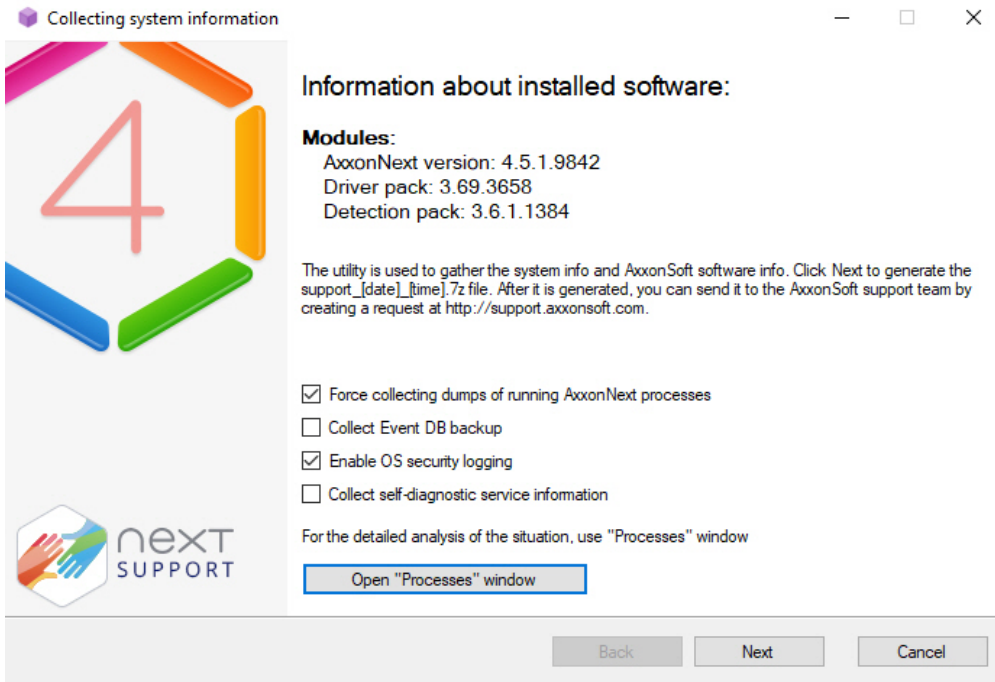

To close the Support.exe utility, click the **Cancel** button or .

9.3.3 Description of the Support.exe utility interface

The Support.exe user interface includes the following elements:

1. Summary of installed software (1).
2. Short instructions on how to use the Support.exe utility (2).
3. Check boxes for configuring data collection (3).
4. A button for launching the **Processes** service, which offers an in-depth situation analysis (4).
5. A button for starting the information gathering process (5).

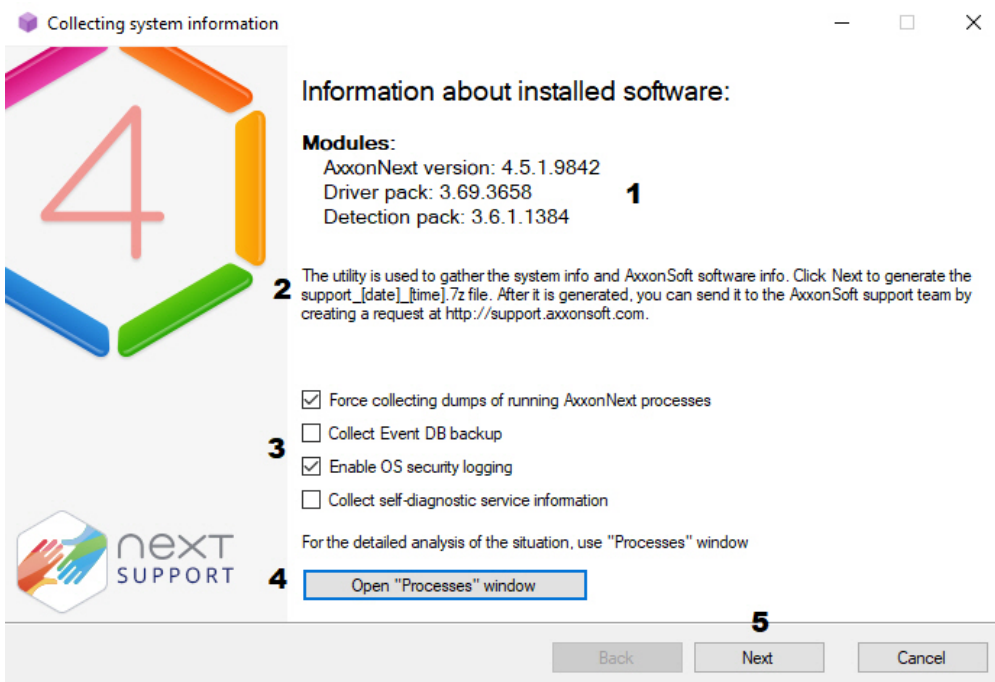

9.3.4 The Processes Service

The **Processes** service is used for detailed analysis of a situation. To launch it, click the **Open Processes window** button; the **Processes** window will then appear, displaying information about processes running on the computer initiated by the Support.exe utility.

PID	Process name	CPU us...	Memory	Workin...	Read	Process...	V.mem.	Written
1248	AXXON.MiscMMSS		18 MB		424 KB	NT AU...	93 MB	0 MB
2232	AXXON.Detector_0	32.8%	146 MB		2854 KB	NT AU...	581 MB	0 MB
2388	AXXON.VMDA		209 MB		183 KB	NT AU...	422 MB	73 MB
2532	AXXON.NVR_PRO...		5 MB		168 KB	NT AU...	90 MB	0 MB
2720	AXXON.NVR_ARC...	0.51%	60 MB	-3072 KB	1066874...	NT AU...	255 MB	183962...
3016	AXXON.Bootstrap		11 MB		96462 KB	NT AU...	89 MB	1996 MB
3256	AXXON.Discovery		53 MB		5484 KB	NT AU...	319 MB	0 MB
3608	AXXON.FileBrowser		5 MB		169 KB	V-BELY...	62 MB	5 MB
3780	AXXON.InfraServer		1 MB		168 KB	NT AU...	58 MB	0 MB
3932	AXXON.Ipint		41 MB		1264635...	NT AU...	193 MB	0 MB
3940	AXXON.MMSS		4 MB		168 KB	NT AU...	86 MB	0 MB
3952	AXXON.NVR	0.51%	65 MB		76265 KB	NT AU...	319 MB	2658 MB
3964	AXXON.Notification	3.07%	77 MB		4054 KB	NT AU...	363 MB	5904 MB
4140	AXXON.Decoder_0	9.35%	110 MB		168 KB	NT AU...	245 MB	0 MB
7176	AXXON.Detector_1		18 MB		170 KB	NT AU...	91 MB	0 MB

A list of all possible Axxon Next processes is given in the table.

Process	Description
AXXON.Discovery	Process that searches for peripheral devices (video cameras, analog video cards, devices connected to a serial port, etc.)
AXXON.VMDA	Process responsible for the metadata database. Writes metadata and searches the archive.
AXXON.MMSS	Web server process
AXXON.Notification	Process for managing events in the system and creating a database of these events
AXXON.AxxonNext	GUI process
AXXON.Bootstrap	Main process responsible for configuration, licensing, storing settings, and starting other processes
AXXON.FileBrowser	Process that provides access to the file system and information about server files
AXXON.NVR	Logic module responsible for alarms and automatic rules
AXXON.InfraServer	Process responsible for interaction between Axxon Next modules

AXXON.Decoder	Process that performs decoding of multimedia streams
AXXON.Detector	Process that performs detection
AXXON.Proxy	Process that performs buffering and grooming of multimedia streams
AXXON.NVR_Archive	Process that writes multimedia data to the archive
AXXON.Ipint	Process that interfaces with the Drivers Pack
AXXON.MiscMMSS	Process that plays back audio on the server audio card

Note

Selecting the **Show info on all system's processes** check box enables viewing of all processes running on the computer.

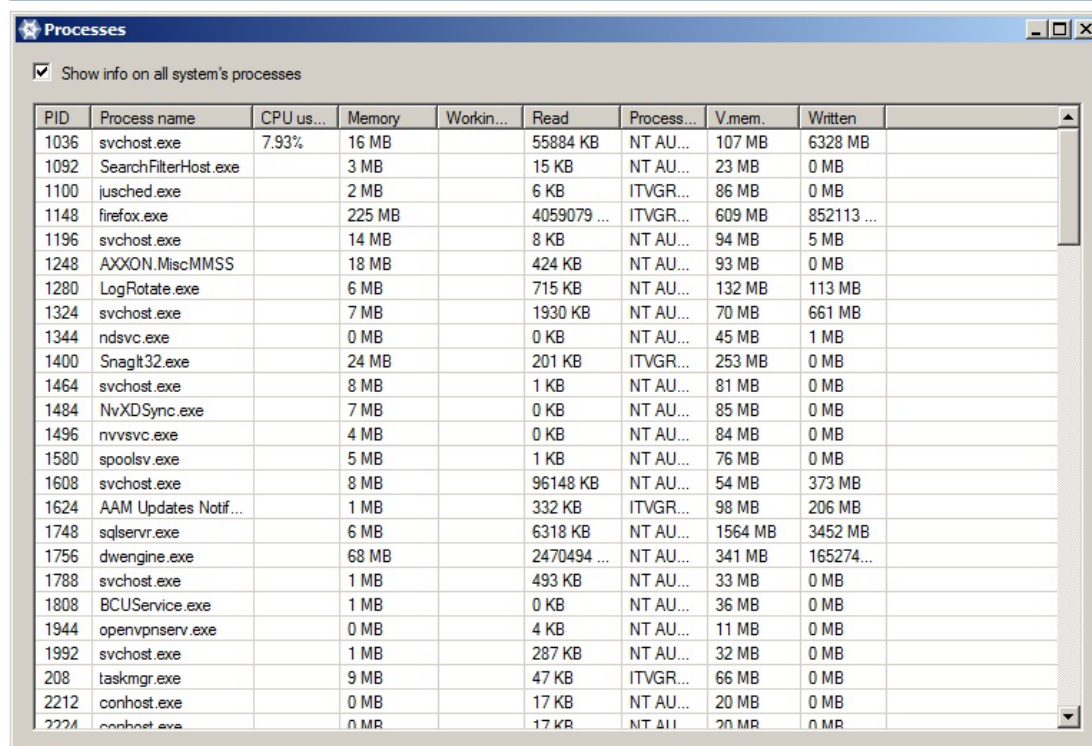

Click the button to close the **Processes** window.

9.3.5 Collecting Data on the Configuration of Servers and Clients Using the Support

To collect data using the Support.exe utility, perform the following:

1. Launch the Support.exe utility (see the section [Launching and Closing the Utility](#)).

7. When information collection is complete, click the **Next** button.

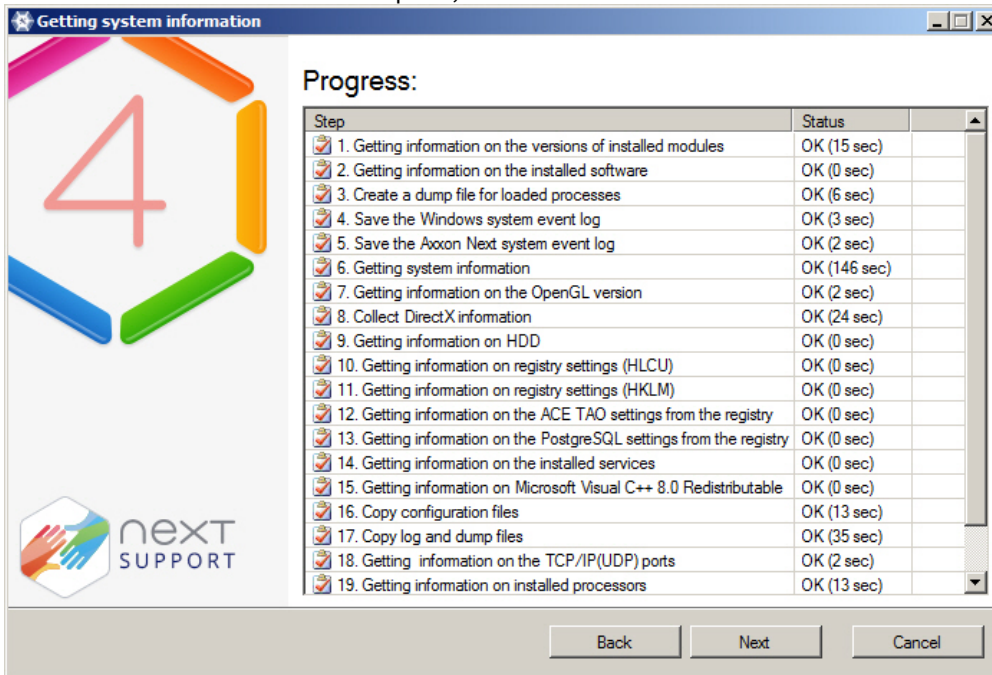

8. A window containing information about the generated archive **support_[date]_[time].7z** will then appear. You can access the folder containing this archive by clicking the **Open directory with file** button.

Note

The archive is located in the folder <System disk>:\Documents and Settings\<Current User>\My Documents if you're using Windows XP, or in the folder <System disk>:\Users\<Current User>\Documents if you're using Windows Vista

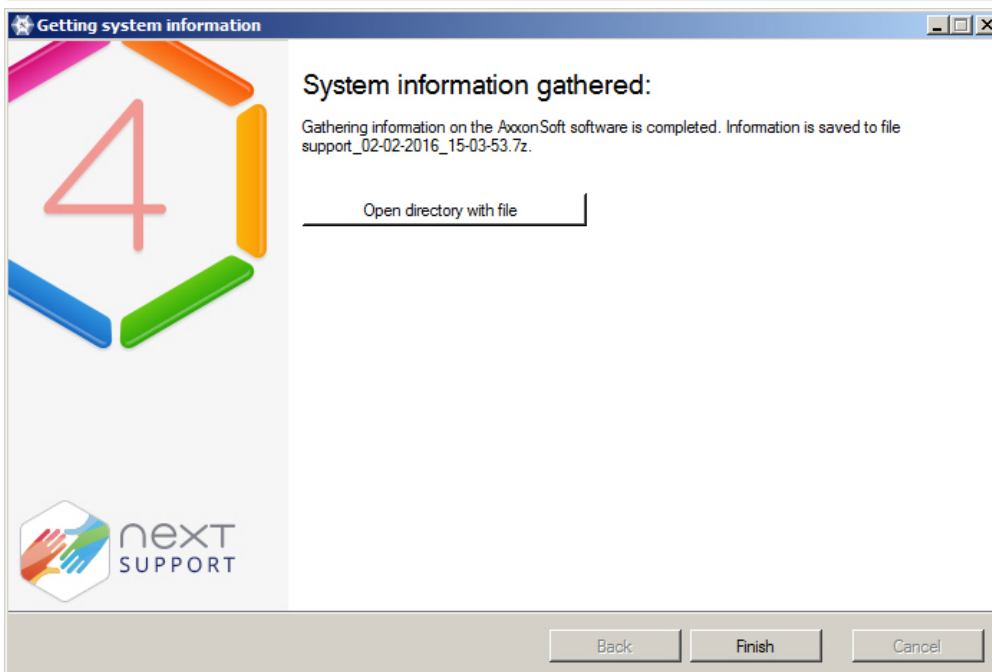

9. Send an email with the attached **support_[date]_[time].7z archive** to the ITV technical support department.

9.4 Log Management Utility

By default, information about all system events is recorded in the Axxon Next system log, which is stored in a local database of the server. It is possible to record information about desired events in external logs, which are log files stored in local directories of a server. Log data is archived at set intervals and moved to the log archive. Configuration of these capabilities is carried out through the log management utility.

Axxon Next component	Log storage directory
Server	<Axxon Next installation folder <i>Axxon Next</i> >\logs
Client	<Letter of system disk>:\Users\<User>\Appdata\Local\AxxonSoft\AxxonNext\logs (for Windows 7 and Windows Vista) <Letter of system disk>\ <Letter of system disk>\Documents and Settings\User\Local Settings\Application Data\AxxonSoft\AxxonNext\Logs (for Windows XP)

The log management utility is used to configure the following parameters:

1. Parameters for the archive of external logs containing information about system events.
2. Logging levels for the Axxon Next client and server.

9.4.1 Starting and closing the utility

The log management utility can be launched using the **Start** menu, which is intended for launching user programs in Windows. **Start** → **All Programs** → **Axxon Next** → **Utilities** → **Logs Archiving**

Note

The log management utility is located in the folder <System disk>:\Program Files\Common Files\AxxonSoft\LogRotate

The log management utility dialog box will then appear.

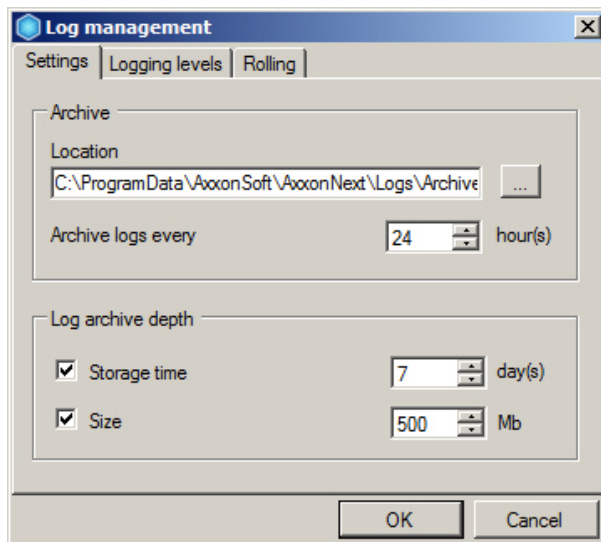

To close the log management utility, click the **Cancel** button or  (accessible in both tabs of the utility).

9.4.2 Configuring a Log Archive

Configuring a log archive is carried out in the Settings tab of the log management utility.

To configure a log archive, you must perform the following steps:

1. In the **Archive location** field (1), enter the complete path to the directory to which the event logs should be moved after archiving.

Note

To set the path using standard Windows methods, click 

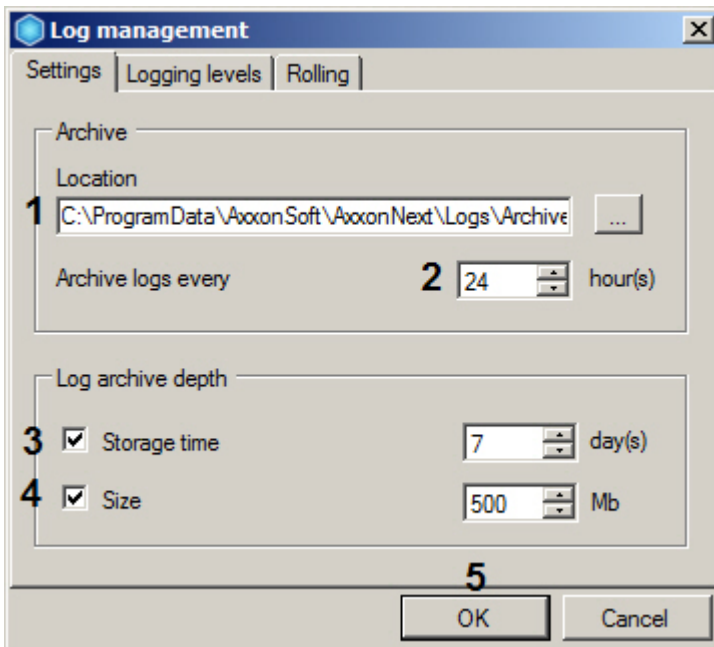

2. In the **Archive logs every...hours** field (2), enter the interval for event log archiving, in hours.
3. In the **Log archive depth** group, set the following parameters:
 - a. In the **Storage time** field (3), indicate the maximum retention time in days of a log in the archive, after which the log is deleted.
 - b. In the **Size** field (4), indicate the maximum size of the archive, above which the oldest logs are deleted from the archive.

Note

Archive disk space restrictions take priority over log retention time restrictions. For example, the oldest logs will be automatically deleted even if their retention time has not expired, if the archive size has exceeded the maximum value

Note

If it is not necessary to impose any limitations on log retention period and/or size, clear the corresponding check boxes in the **Log archive depth (3-4)**

4. Click **OK (5)** to save changes.

Configuration of the log archive is now complete.

9.4.3 Configuring Logging Levels

logging levels differ in the list of events to be recorded in external logs, as well as the level of event specification (low, medium, high). Configuration of levels is carried out in the **logging levels** tab of the log management utility.

To configure the logging level, you must perform the following steps:

1. Select the desired logging level of the client (Axxon Next Client) and the server (Axxon Next Server) **(1)**.

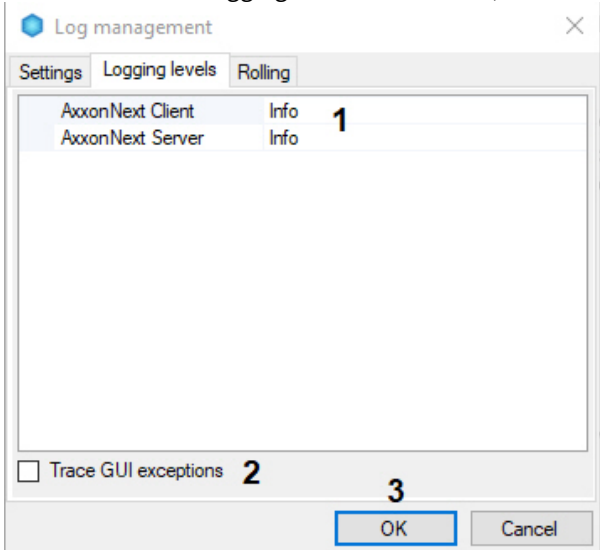

Note

If you change the logging level of a Server, the server will be restarted.

Note

If the Axxon Next VMS is installed in the **Failover Server and Client** configuration, you can log in as either a Client or a Supervisor.

logging level	logging level description
None	Event logging disabled
Error	Low specification level – only system errors are logged
Warning	Low level of detail - only system warnings and system errors are logged
Info	Low level of detail - logs informational messages, system warnings, and system errors
Debug	Medium level of detail - logs debugging events, informational messages, system warnings, and system errors
Trace	High specification level – all system events are logged

2. If you need to include GUI exceptions into the logs, select the corresponding check box **(2)**.
3. Click **OK (3)** to save changes.

Configuration of logging levels is complete.

9.4.4 Set the size and maximum number of logs

To adjust the size and maximum number of logs:

1. Switch to the **Rolling** tab.

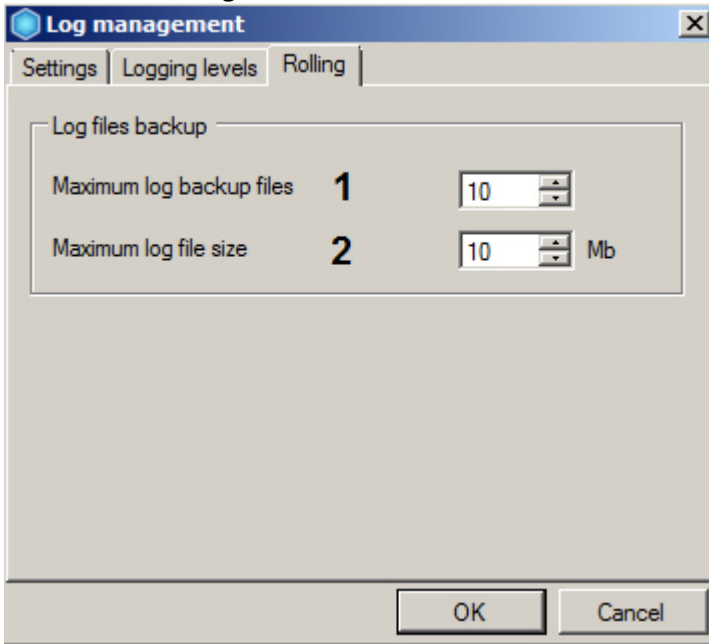

2. Set the maximum number of logs (1).
3. Set the maximum size of the log in megabytes (2). When the specified size is reached, a new log is created.
4. Click **OK** to save changes.

9.4.5 Configuring Client RAM usage logging

You can log Client RAM usage at specified intervals (AxxonNext.exe process). To do this:

1. Quit Client (see [Shutting down an Axxon Next Client](#)).
2. Open the *AxxonNext.exe.config* configuration file, located in the <Installation Directory PC Axxon Next> \ bin., in a text editor.
3. Find the **MemoryUsageDumpIntervalSeconds** option and set a value for it, corresponding to the period of adding the information to the log in seconds.

```

AxxonNext.exe - Notepad
File Edit Format View Help
<add key="MaxAlertPreviewWindowZoom" value="5"/>
<add key="AlertPreviewSize" value="30"/>
<add key="MultiplierAlertPreviewWindowZoom" value="3"/>
<add key="DeltaToDetectAbsenceOfArchiveRecord" value="2000"/>
<add key="MapSlideAnimationTime" value="300"/>
<add key="CameraSelectAnimationTime" value="400"/>
<add key="LinkLineAnimationTime" value="1200"/>
<add key="MapTopViewPortPositionAnimationSpeed" value="40"/>
<add key="MapImageZoomAnimationSpeed" value="200"/>
<add key="MapOnlyViewModeTransformationTime" value="400"/>
<add key="SlideButtonAnimationTime" value="200"/>
<add key="ImmersionModeTransformationTime" value="800"/>
<add key="MapImageMaxSizeInPixels" value="4000000"/>
<add key="AutoResolutionSelectPercentLimit" value="10"/>
<add key="MemoryUsageDumpIntervalSeconds" value="5"/>
<add key="EnableHighProcessPriority" value="true"/>

```

Note

Value **0** - no information is logged.

4. Save the changes to the file.
5. Run client (see [Starting an Axxon Next Client](#)).

Here is an example of the client RAM usage information in the log:

```
*** Memory usage: ***  
Private size 425 MB  
Working set 404 MB
```

Private size - the amount of reserved memory.

Working set - memory footprint.

9.5 Digital Signature Verification Utility

This utility verifies the digital signature that is added during export of video and snapshots from Axxon Next.

To start the utility, open the standard **Start** menu in Windows: **Start > Programs > Axxon Next > Utilities > Watermark checker**.

Note

The utility executable file WatermarkCheck.exe is also located in the folder <Directory where Axxon Next is installed>\Axxon Next\bin\.

To check a digital signature, click the **Open file** button and select the file of the exported snapshot or video.

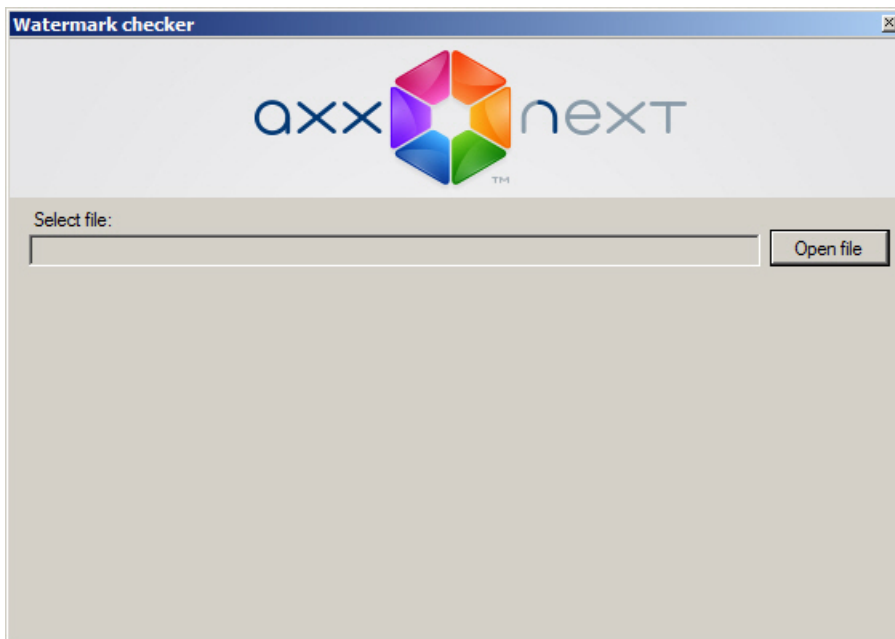

If the digital signature is valid, the utility will show the message: **Signature check: OK!**

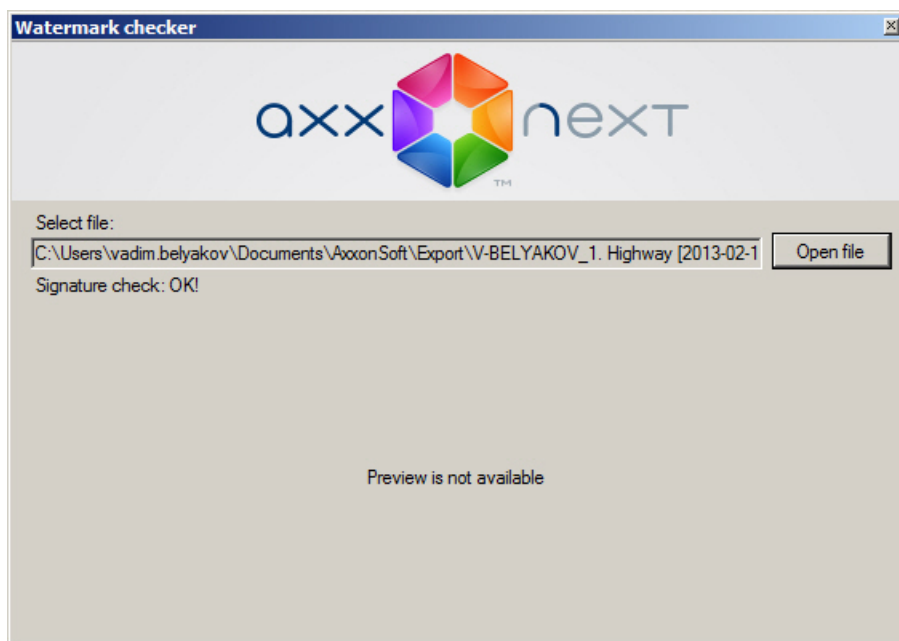

If it is not valid, the utility will show the message: **Signature check: Invalid signature!**



Note

During verification of a digital signature, the thumbnail of a snapshot is shown in the utility window. Videos cannot be previewed during the verification process

Digital signature verification is now complete.

To quit the utility, click the  button.

9.6 Backup and Restore Utility

9.6.1 Purpose of BackupTool.exe

BackupTool.exe allows system users to save a copy of the system configuration, roll back the configuration to a previous version, and restore the system configuration from a previously created copy.

Attention!

The backup and restore utility may be applied to both the local configuration of a selected Server (including video cameras, archives, detection tools, event sources, logging levels) and the global configuration of the Axxon domain (users, maps, layouts, etc.).

This utility can also be used to change the name of the local Server.

9.6.2 Starting and quitting BackupTool.exe

Start BackupTool.exe from **Start -> All Programs -> Axxon Next -> Utilities -> Backup and Restore**, or from the tray menu (see the [Axxon Next Tray Tool](#) section).

Note.

The BackupTool.exe executable is located at <Axxon Next installation folder>\AxxonNext\bin\.

After you perform this action, BackupTool.exe displays a dialog box.

Then select the name of an Axxon-domain Server whose configuration you want to use and log in to it, using the name and password of an Axxon Next administrator.

A progress indicator is displayed.

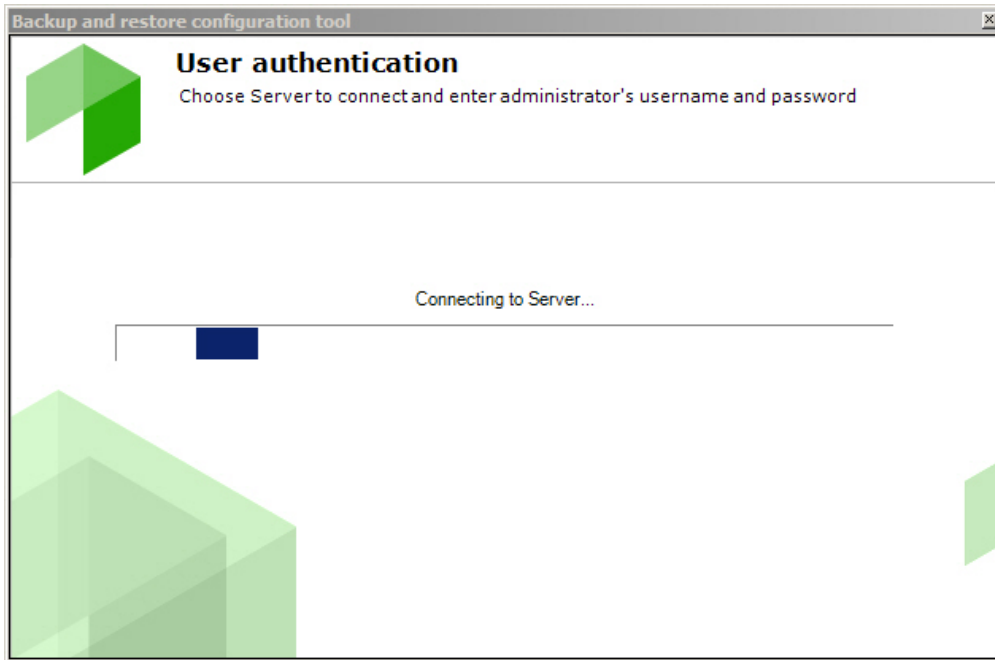

After loading is complete, the main page of the Backup and Restore Utility is shown.

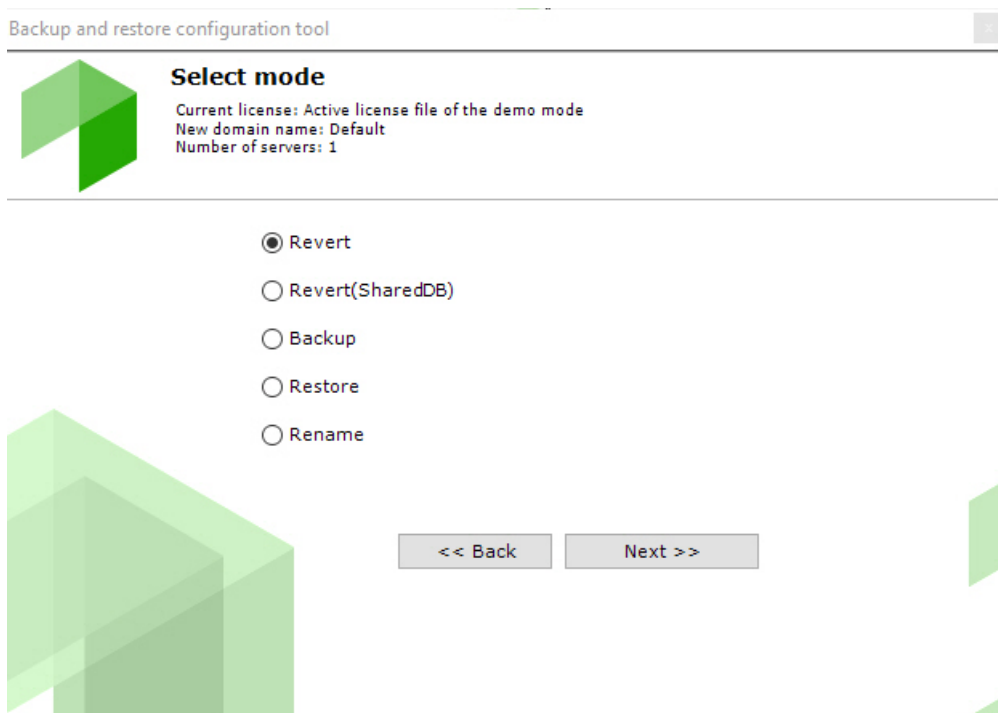

To quit BackupTool.exe, click the  button.

9.6.3 Roll back the local configuration to a selected restore point

The system creates a restore point when the local configuration of the Server is changed (creation / deletion / changing settings of any objects, linking cameras to different archives, etc.). You can roll back your configuration to any available restore point at any time.

To roll back, on the main page of the Backup and Restore Utility, set the switch to the **Revert** position (1). To continue, click the **Next >>** button (2).

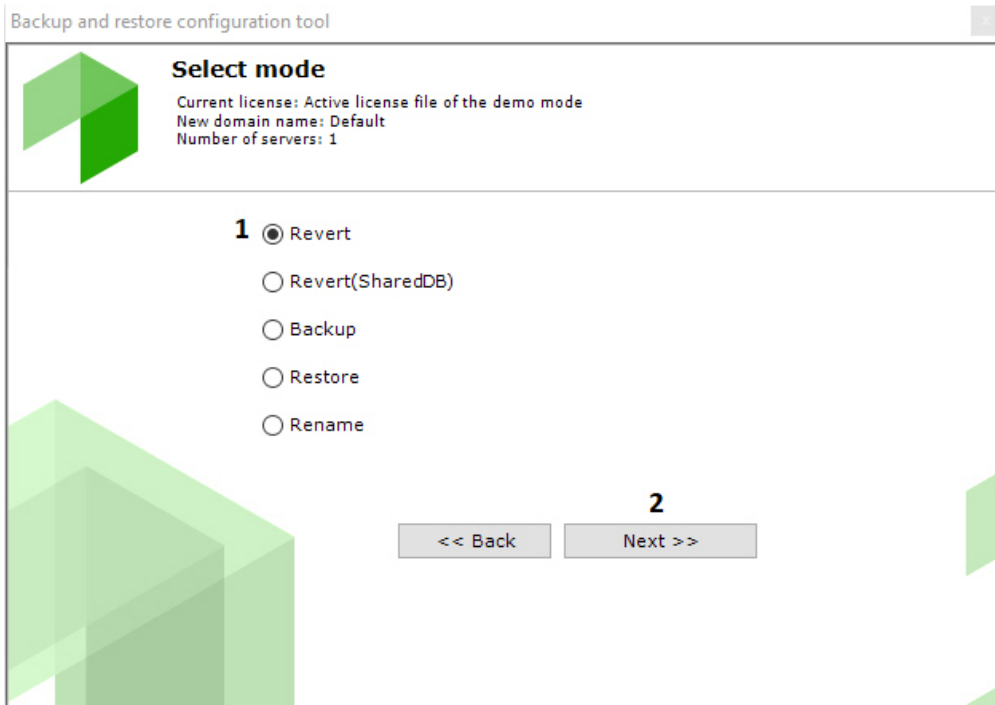

A window then opens, displaying a list of available restore points and their respective creation times, with a description of what was changed.

Note.

If multiple changes were made in a configuration but the **Apply** button was clicked only once, only one restore point is created in the list.

In the list, select the restore point to which you want to roll back. To continue, click the **Next** button (2).

Note.

Empty configuration corresponds to when the system was first created.

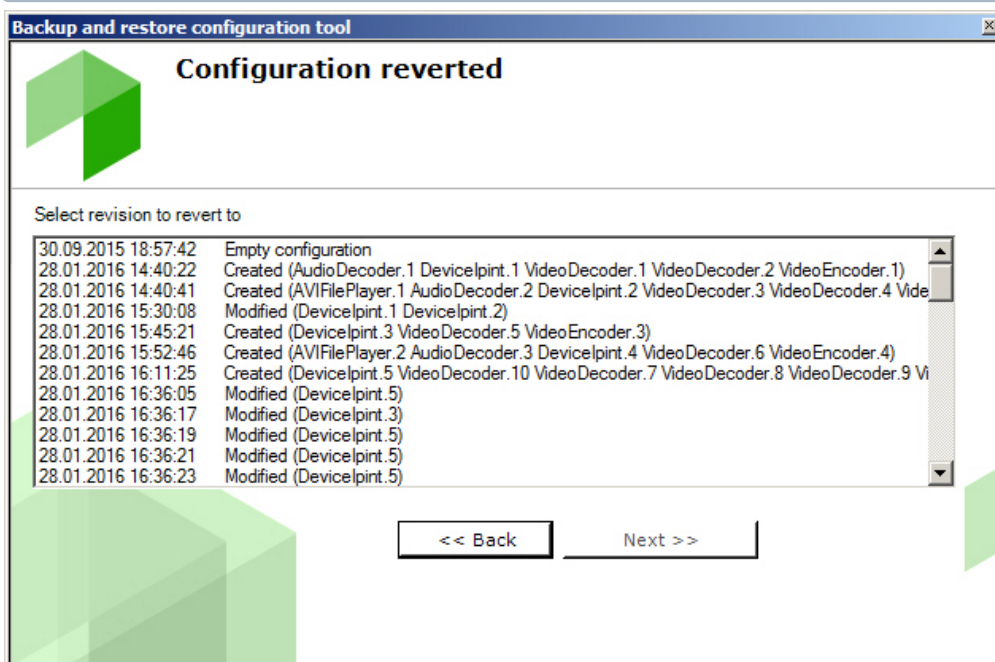

Rollback of the configuration now begins.

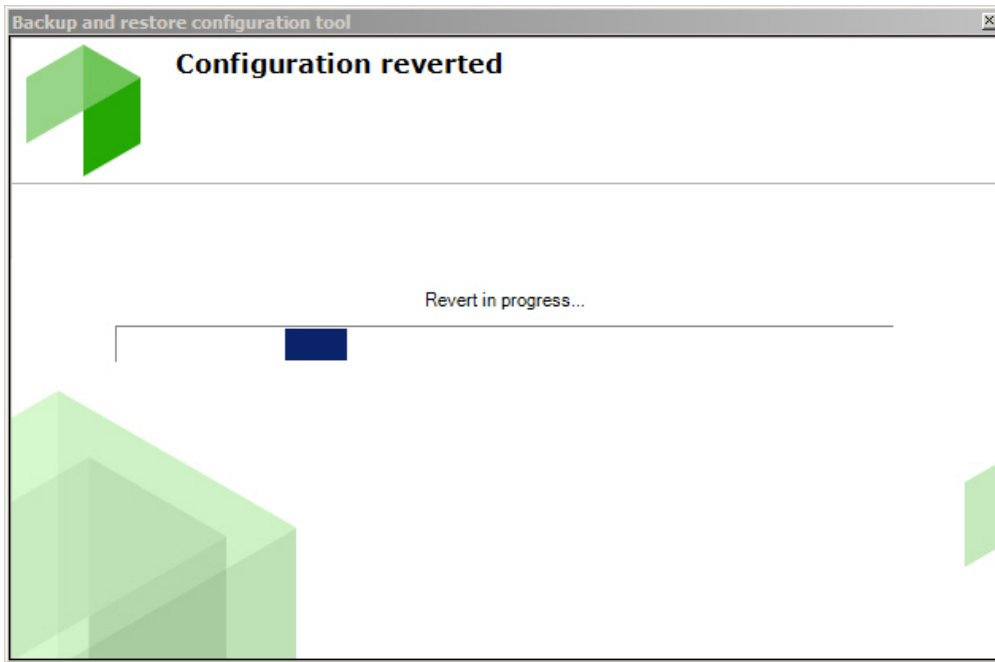

After the operation is completed, a message is shown to notify of successful rollback.

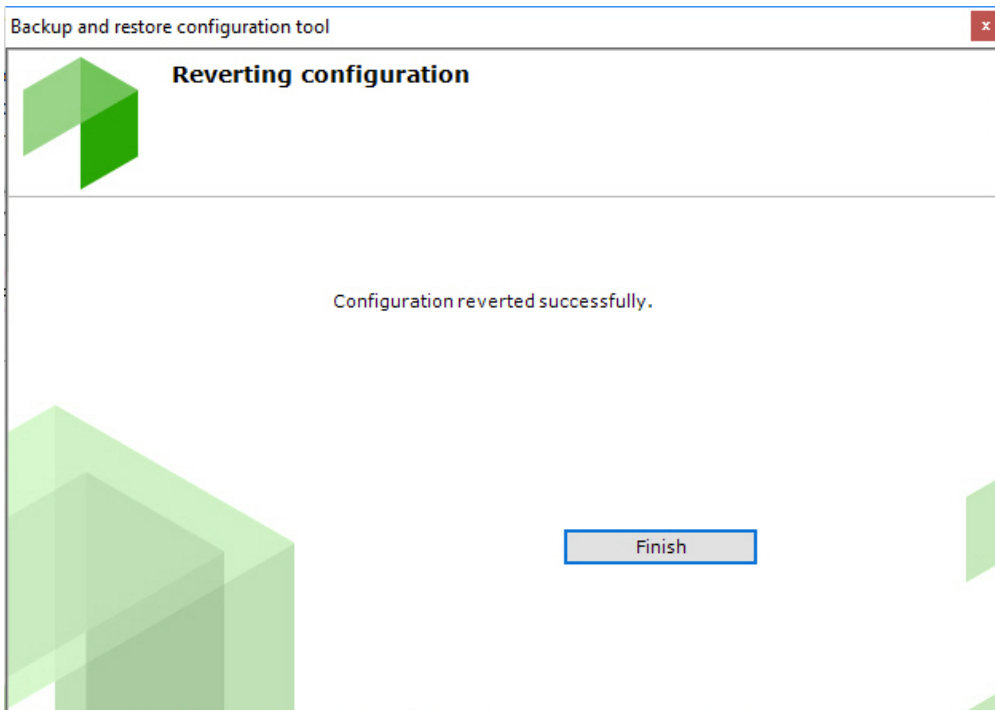

To close the window, click the **Close** button.

9.6.4 Roll back the global configuration to a selected restore point

The system creates a restore point when the global configuration of the Axxon domain is changed (creation / deletion of roles, users, maps, layouts, etc.). You can roll back your configuration to any available restore point at any time. To launch the roll back process, go to the main page of Backup and Restore Utility (1) and set the switch to the **Revert (SharedDB)** position. To continue, click **Next >>** (2).

Backup and restore configuration tool

Select mode

Current license: Active license file of the demo mode
 New domain name: Default
 Number of servers: 1

Revert
1 Revert(SharedDB)
 Backup
 Restore
 Rename

Further steps are the same as for rolling back the local configuration (see [Roll back the local configuration to a selected restore point](#)).

9.6.5 Backing up a configuration

Backing up a configuration involves creating and saving copies of the license key, domain structure, all created objects along with their parameters and relationships with history of changes, as well as database containing users, groups, passwords, and layouts.

Attention!

We recommend you to back up your configuration after any major change in system configuration.

To create a backup of the system configuration:

1. On the main page of the Backup and Restore Utility, set the switch to the **Backup** position.

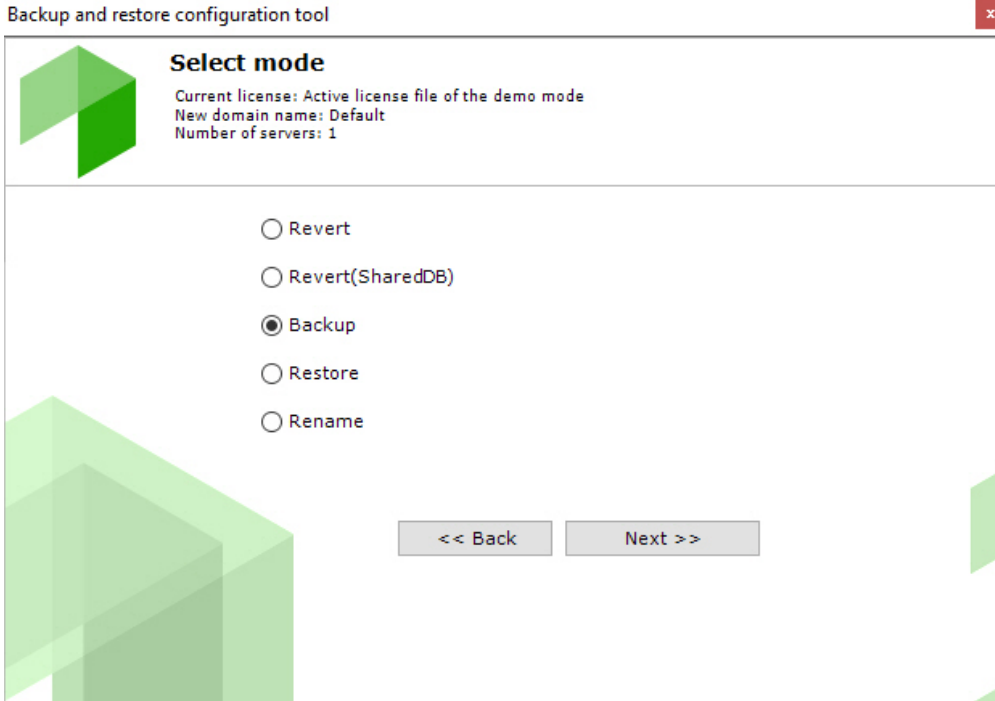

A window then opens for configuring backup options.

2. In the field (1), specify a folder for saving the backup. The default folder is C:\users\username\documents\axonsoft\backups\. To switch to a different folder, click **Browse** and select a folder in the dialog box.

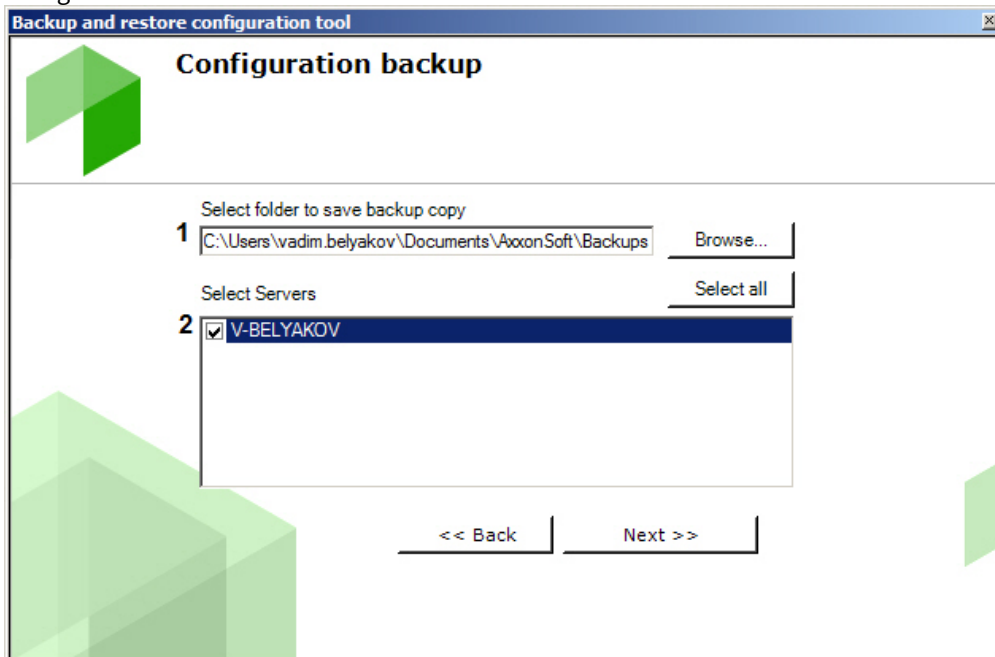

Note

For each copy of the backup configuration, a separate folder is created. The folder name contains the date and time of the backup copy and has the following format: YYYYMMDDHHMMSS. The default time zone is UTC + 0

3. In the other field (2), select servers for creating the backup. You can select multiple servers. To select all servers, click the **Select all** button. Start the backup process by clicking the **Next** button.

Progress information is shown in the following window.

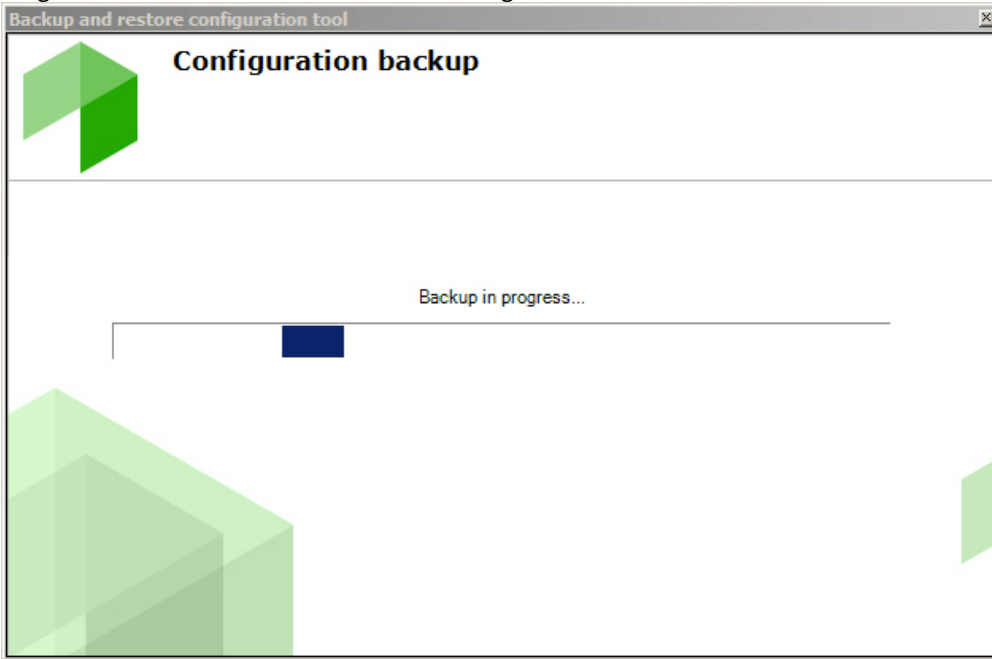

4. When the backup is complete, a window notifies of successful copying.

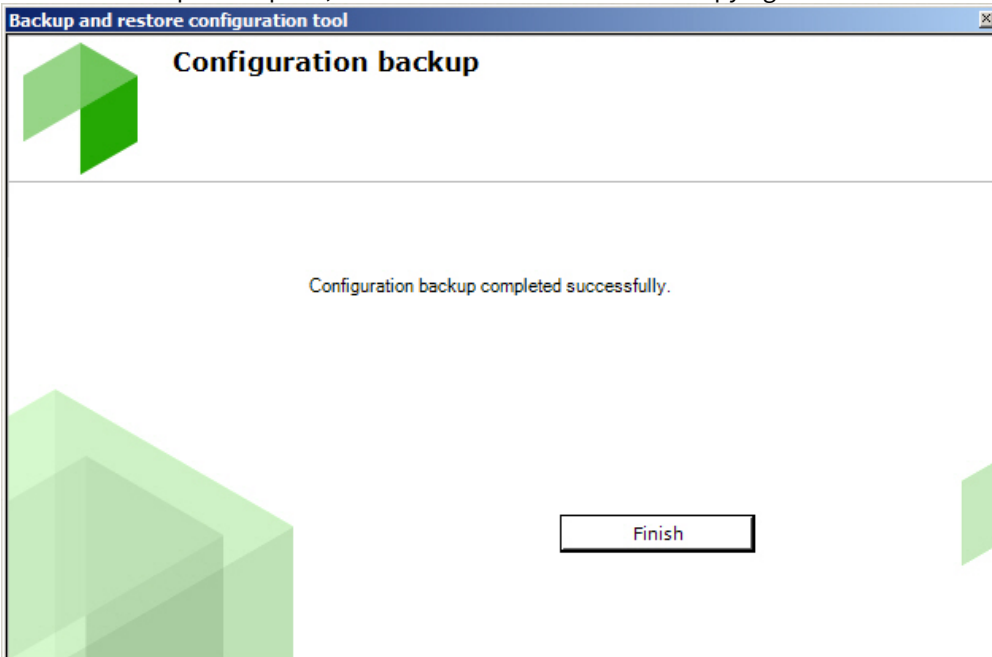

5. To close the window, click the **Close** button.

A backup of the configuration has now been created.

9.6.6 Restoring a configuration

Attention!

We can guarantee that your configuration will be fully recovered if:

- the backup was created on the same software version (including the build number);
- the backup was created on the same PC (for licensing without the Guardant key).

The information about the product version and the PC's HID can be found in a JSON file in the saved configuration folder.

Attention!

To successfully restore a configuration, please ensure that the current Server name is exactly the same as the Server name in the backup configuration.

To restore a configuration:

1. On the main page of the Backup and Restore Utility, set the switch to the **Restore** position.

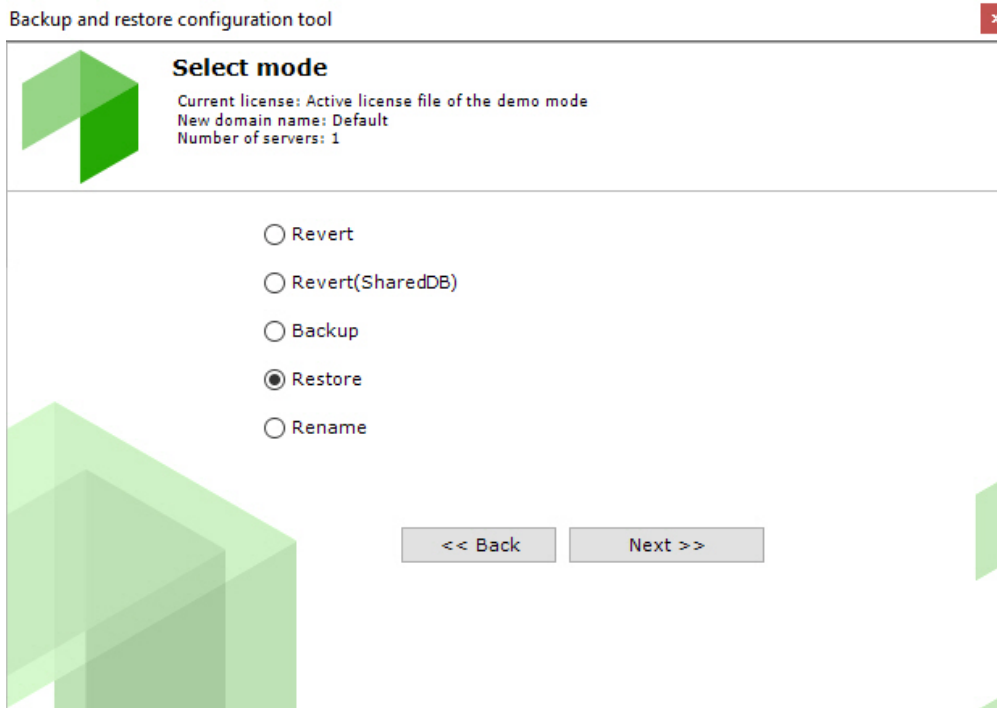

A window then opens for configuring restoration of the configuration.

- In the field (1), specify the file containing the configuration backup.

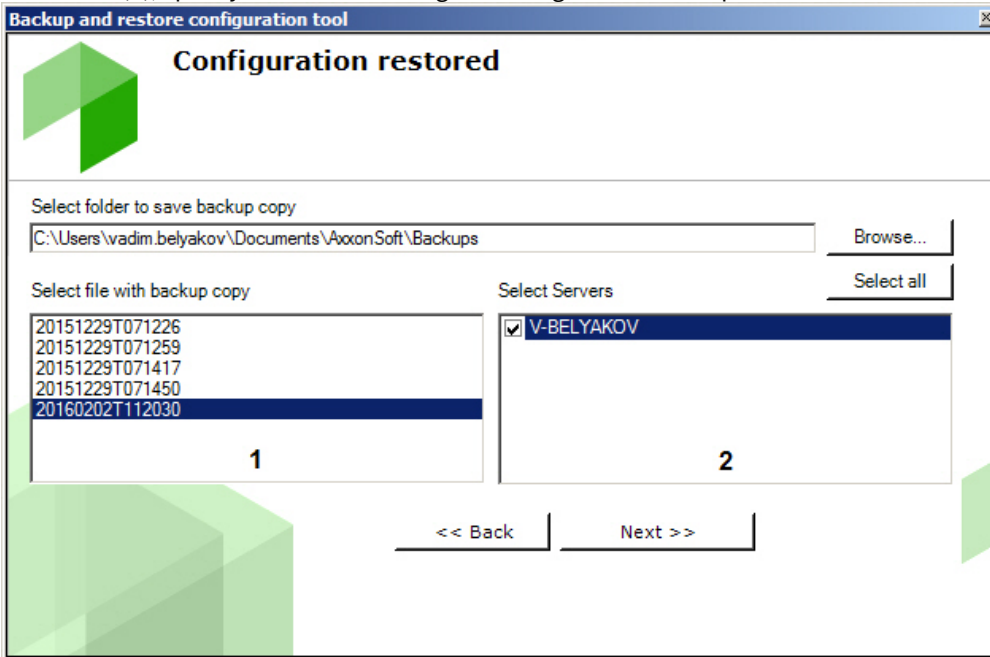

- After the file is opened, the servers on the current domain are displayed in the other field (2). You can select a server in the list only if it is on the domain and the open file contains the corresponding backup. To start restoration, click the **Next** button.

Progress information is shown in the following window.

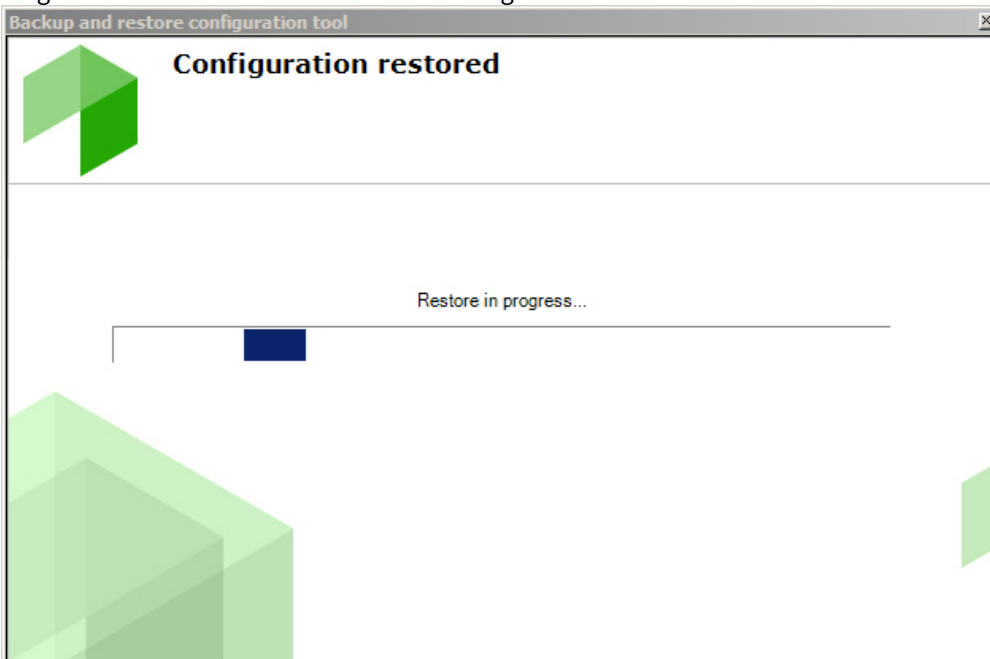

- When restoration is complete, a message informs of successful completion.

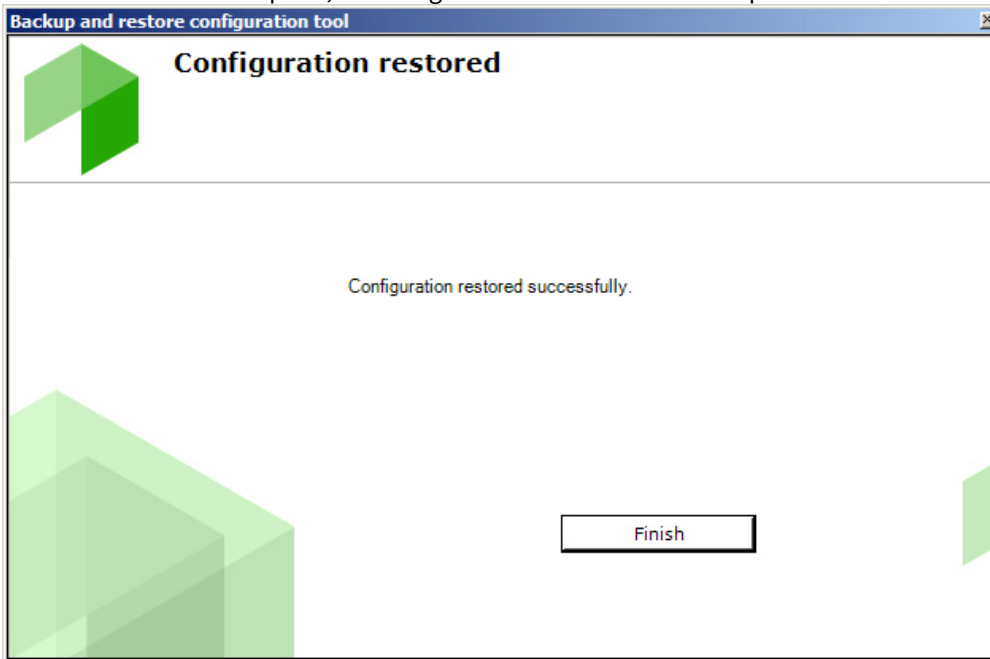

- To close the window, click the **Close** button.

Restoration of the configuration is now complete.

9.6.7 Changing the Server Name

To change the local Server name using the Backup and Restore Utility, perform the following steps:

Attention!

After this command is completed, the server is excluded from Axxon domain. You cannot access recorded video (Archive). All custom layouts, maps, automatic rules and macros are deleted.

- Connect to the Server that requires a name change (see [Starting and quitting BackupTool.exe](#)).

2. Select **Rename** and click **Next** on the utility main page.

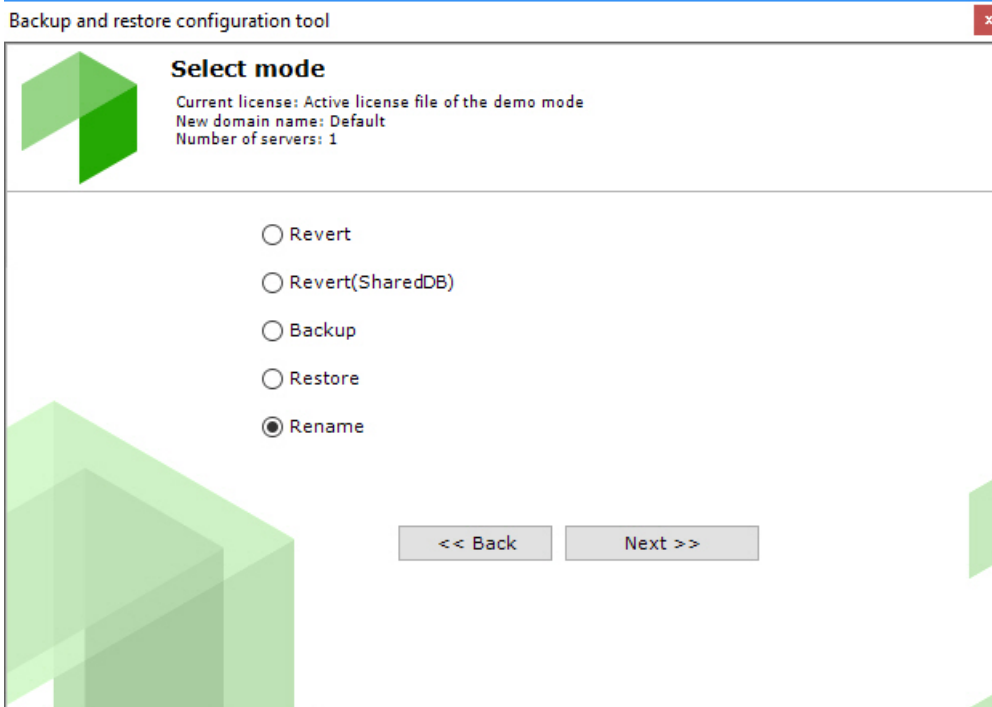

3. Enter the new Server name and click **Next**.

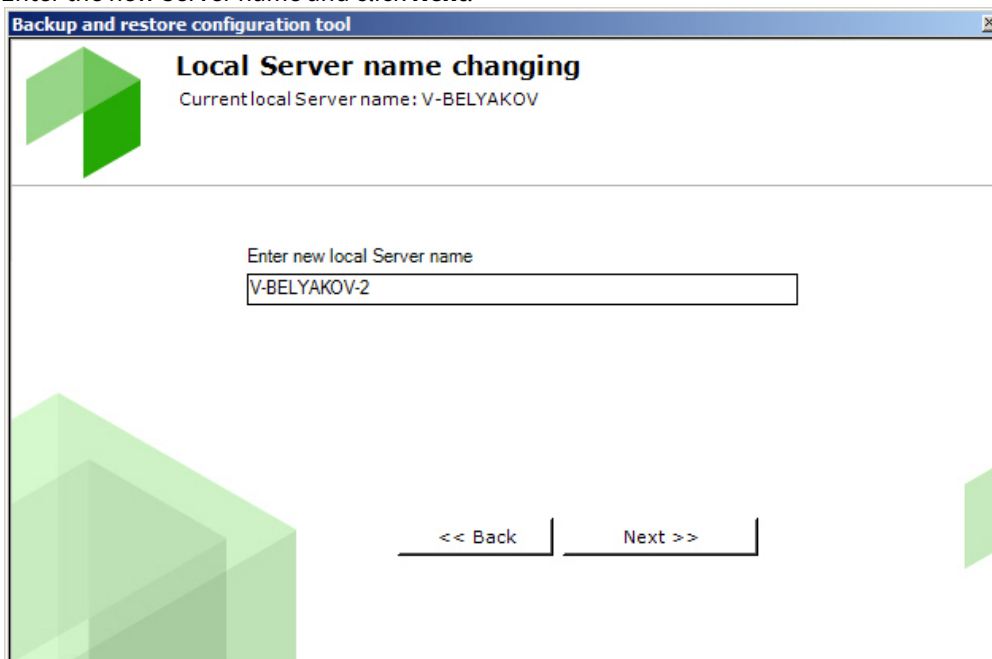

The Server name change process will start.

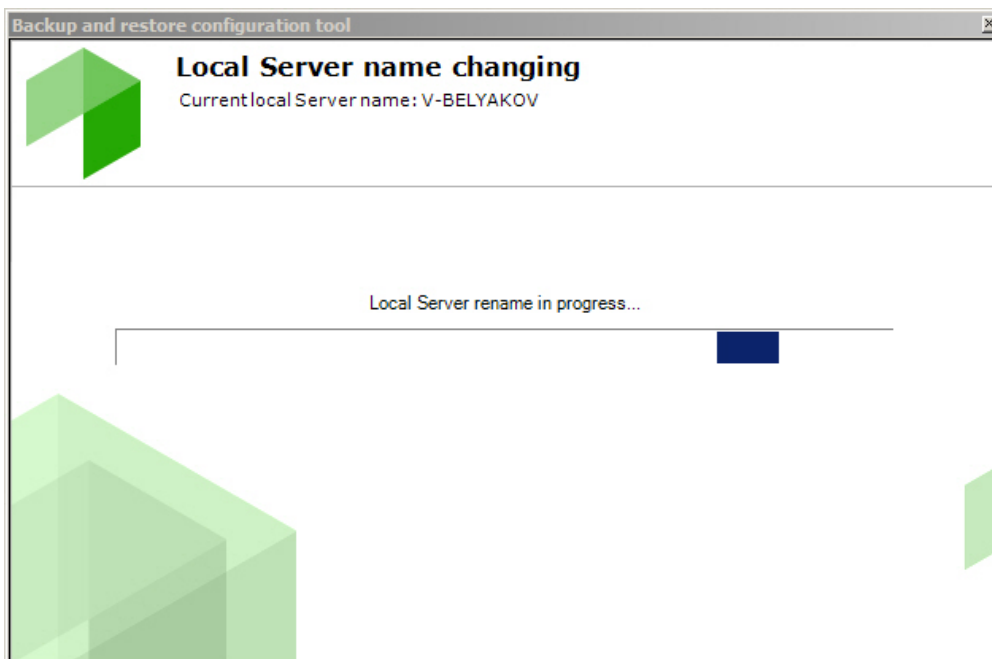

If the operation completes successfully, a notification message will appear.

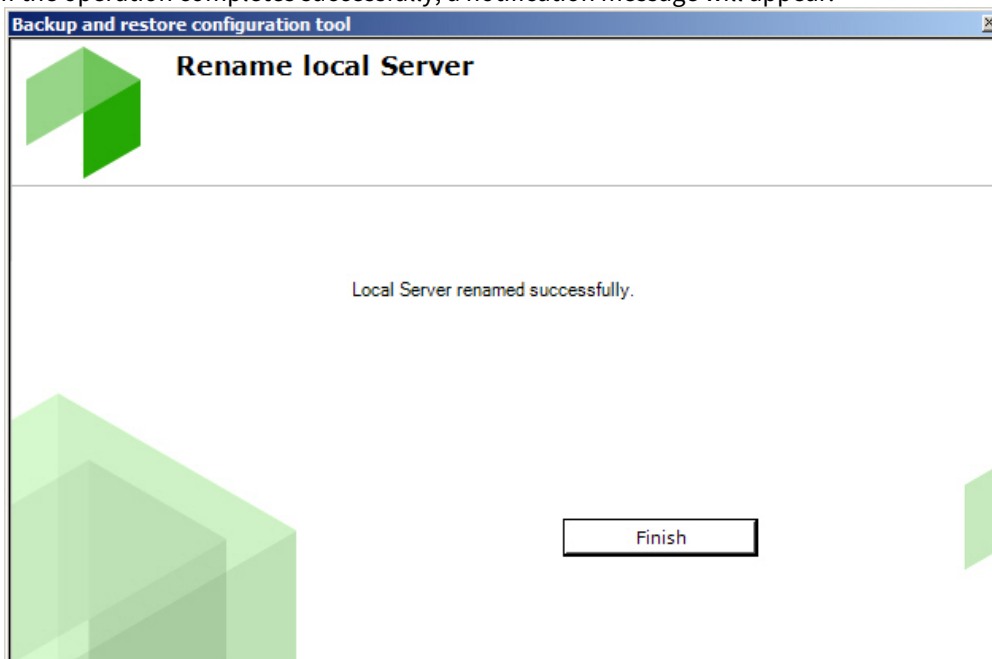

Server name change is complete.

9.7 POS-terminal log collection utility

Follow these steps to gather required information about POS terminal using a special utility:

1. If the POS-terminal supports data transmission over Ethernet or via the COM port, download the POS Terminal Data Collection Utility at the [AxxonSoft web-site](#).
2. Extract downloaded archive into any folder.
3. Connect the POS terminal to the computer.

4. Run the Protocollicenser.exe executable file. The **Read protocol from service** window opens.

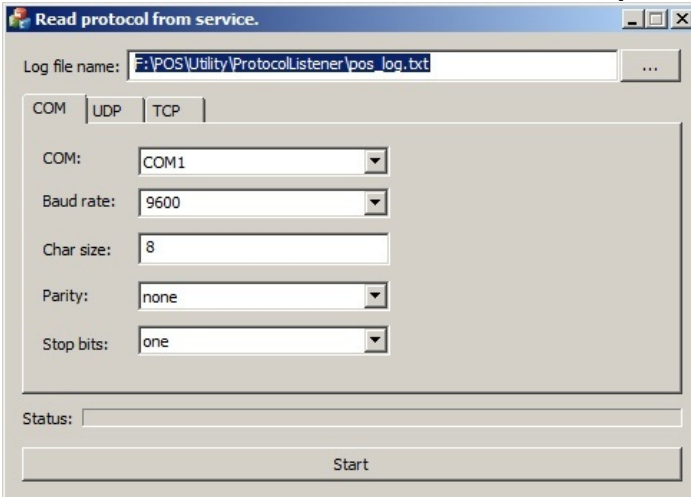

5. In the **Log file name** field specify a full path to the folder where the file with gathered info is to be saved. By default, the file is stored in the folder to which the archive with the utility is unpacked.
6. If the POS-terminal is connected to the computer via COM-port, specify connection parameters in the **COM** tab.
7. If the POS-terminal is connected to the computer via Ethernet, specify connection parameters for TCP or UDP protocol in the corresponding tab.
8. Click **Start** to run log collection.
9. Start using the POS-terminal, i.e. issuing receipts. It is highly recommended to do all the operations including Cancel, Return, etc.

Process of gathering info is displayed via the **Status** progress bar.

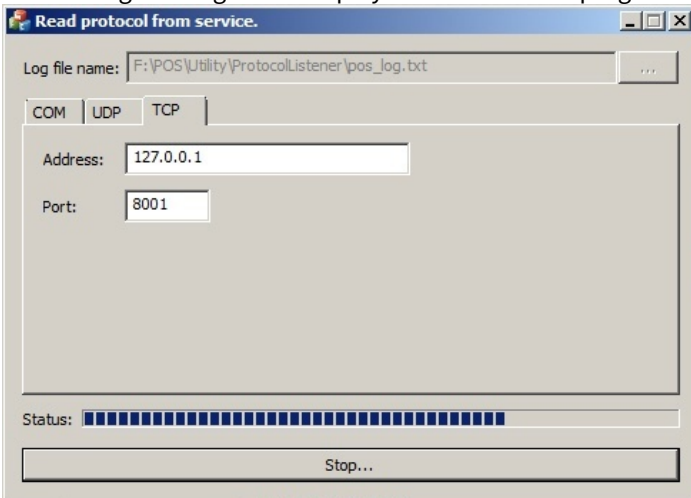

To finish log collection click **Stop**.

After doing all the operations on the POS-terminal, send the log file with copies of receipts to AxxonSoft.

Important!

If the log file of POS-terminal is to be processed in software, then provide AxxonSoft with protocol description. POS-terminal manufacturer can give this information.

9.8 Console utility for working with archives

vfs_format.exe is a console utility for working with *Axxon Next* archives.

Attention!

For correct operation of the application, you have to remove the corresponding archive volume in Axxon Next without removing the archive files (see [Deleting and formatting archive volumes](#)).

The utility is located in < Axxon Next installation folder > \bin>.

Attention!

Run the command line as Administrator.

Note

To launch the utility on Linux OS, run the following command:

```
ngprun start_app vfs_tools + arguments.
```

To open the argument list, run the `vfs_tools --help` command.

The utility contains the following options:

Parameter	Description
--help	Help window
--volume	Archive path. The basic parameter must always be present in the query. For example: <code>vfs_format.exe --volume D:\archiveAntiqueWhite.afs</code> (for the archive volume as a file) or <code>vfs_format.exe --volume D:\</code> (for the archive volume as a disk)
--fill	Populating an archive with multiple copies of video footage from another archive. The system fills up a destination archive with multiple copies of a source archive; for easier timeline handling, each new copy is written with 1 minute offset. For example: <code>vfs_format.exe --volume S:\FILEONE.afs --fill G:\</code>
--cache-to-memory	Copying an archive to RAM and further copying to a destination archive. Use with the --fill parameter. This parameter is valid only for archives that could fit to RAM. For instance, <code>vfs_format.exe --volume S:\FILEONE.afs --fill G:\ --cache-to-memory</code>
--dump	Collect service information about the archive volume in a TXT or XML file. For example: <code>vfs_format.exe --volume D:\archiveAntiqueWhite.afs --dump C:\DumpArc.txt</code>
--expand	Specify the new size of the archive volume in sectors. By default, the size of one sector is 4MB, if the -format parameter was not applied. This option is relevant only for the archive volume as a file. For example: <code>vfs_format.exe --volume D:\archiveAntiqueWhite.afs --expand 128</code>
--size	Specify the new size of the archive volume in megabytes. This option is relevant only for the archive volume as a file. For example: <code>vfs_format.exe --volume D:\archiveAntiqueWhite.afs --size 4096</code>
--format	Split the volume of the archive into sectors of the specified size (in megabytes). For example: <code>vfs_format.exe --volume D:\archiveAntiqueWhite.afs --format 16</code>

Parameter	Description
--copy	Copying archive volumes. Specify the path and name of the new archive file. If the archive volume is copied as a disk, create a partition, large enough. If you have a smaller partition, then only the most recent entries are copied. For example: vfs_format.exe --volume D:\archiveAntiqueWhite.afs --copy C:\NewArc.afs
--skip-bad-block	Skip the bad sectors when copying the archive volume. This parameter is used only together with --copy . For example: vfs_format.exe --volume D:\archiveAliceBlue.afs --copy C:\NewArc.afs --skip-bad-block
--modify-corrupted-flag	Enable / disable re-indexing of the archive volume. 1 - enable reindexing, 0 - disable. For example: vfs_format.exe --volume D:\archiveAliceBlue.afs --modify-corrupted-flag 1
--build-meta	Launch the process of metadata generation for an archive volume (including timeline markers and video footage size per channel). For example, vfs_format.exe --volume D:\ --build-meta Important! Processing large archives may take significant amounts of time.
--clear-meta	Deleting metadata of archive volume. For example, vfs_format.exe --volume D:\ --clear-meta
--log-level	Sets the logging level for this action. Available values: 0 - OFF 10 - ERROR 20 - WARN 40 - INFO 50 - DEBUG 60 - TRACE 100 - ALL

To log error messages, you must add a path for the log file at the end of each query.

For example: vfs_format.exe --volume S:\FILEONE.afs --fill G:\ --log-level=100 > S:\log.txt

9.9 Network settings utility

You can launch the network setup utility from the Windows Start menu: **Start -> All Programs -> Axxon Next -> Utilities -> Network settings.**

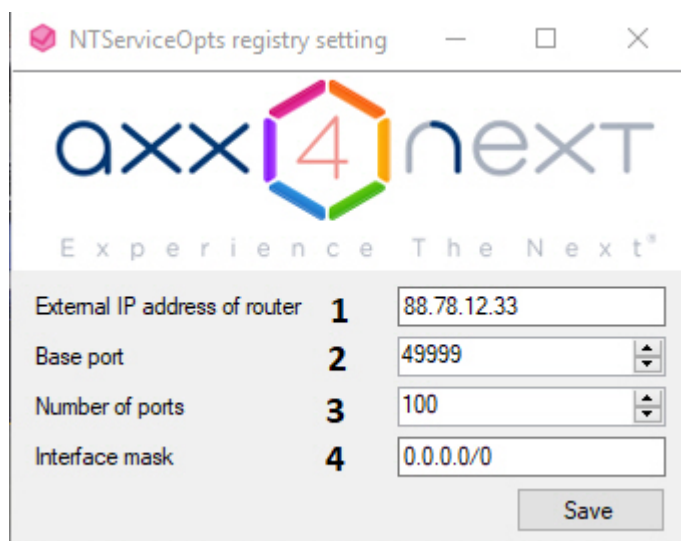

The utility allows you to:

1. Set the external IP address or DNS name of the router if the Server is located behind the NAT (1).

Note

You may set multiple interfaces using a comma separated list, such as: "IP Address1 or DNS Name1, IP address2 or DNS Name2".

For example: 88.78.12.33, [ExampleAxxon.ddns.net](#).

T

2. Set the port range for operation of the *Axxon Next* Server (2-3). To do this, specify the beginning of the range and the number of ports. The number of ports should not be lower than 20.

Attention!

Within an Axxon Domain, the port ranges of Servers should not overlap.

Note

The number of ports that you select affects the scalability of the system. Keep the following in mind when specifying the number of ports:

- **6 ports** is a minimum system requirement for machines with Axxon Next.
- In a 32-bit configuration, for every **32 cameras, 6 ports are** required (for multistreaming cameras). In a 64-bit configuration, for any number of cameras, **6 ports are** required.
- **2 ports are** required to write to the **archive**.
- To use the Object Tracking database (track recording), **1 port** is required.
- To use basic detection tools, **2 ports are** required.
- To use Scene Analytics, **2 ports are** required.
- To use E-mail- (through SMTP), SMS or server audio notification **1 port** is required .

3. Restrict the visibility of Servers from various networks in the Servers list during the *Axxon Next* setup (4). Possible values:
 - a. "0.0.0.0/0" - Servers from all networks will be visible.
 - b. "10.0.1.23/32,192.168.0.7/32" - Only Servers from specified networks will be visible.
 - c. "127.0.0.1" - Only Servers from the local network will be visible.

After you save the settings, the Server will be restarted.

10 Appendices

10.1 Appendix 1. Glossary

Active viewing tile - viewing tile currently in use by the user.

AWS (automated workstation) – security system user workstation, a minimally equipped personal computer with Axxon Next software installed.

Archive – all audio/video files stored on a hard disk that can be played and exported to supported formats.

Default archive of a video camera – the archive to which images from a given video camera are recorded during user-initiated alarms.

Audio detection tool – a detection tool is triggered used to analyze the audio signal from a microphone.

Audio recording – 1. the process of recording a digitized audio signal on a hard disk.
2. audio data stored in a specific format on a hard disk.

The audio subsystem encompasses all the tools that provide for the collection of audio data, its processing, and its storage on media.

Video detection tool – a detection tool is triggered used to analyze the video image from a video camera.

Video recording – 1. the process of recording a digitized video signal on a hard disk.
2. video information stored in a specific format on a hard disk.

Video camera – 1. source of a video signal.
2. a system object displaying the properties of an installed video camera and controlling its operation.

The video subsystem encompasses all the tools that provide for the acquisition of video data, its processing, and its storage on media.

Timeline – an interface object used to search for video recordings and navigate an archive.

Input – 1. a physical device intended for receiving information on the status of an object.
2. a system object that displays the properties of an installed Input.

Situation analysis detection – a detection tool is triggered used to analyze the situation in a camera's field of view according to set criteria.

Audio signal detection– a detection tool is triggered which is triggered by an increase in the signal/noise ratio above a set level.

Loss of quality detection– a detection tool is triggered which is triggered by a loss of quality in the video image from a camera.

Position change detection– a detection tool is triggered by a substantial change in the background of a video image indicating a change in the position of the camera in space.

Object disappearance detection– a detection tool is triggered by the disappearance of an object in a set area of a video camera's field of view.

Abandoned object detection– a detection tool is triggered when an object remains motionless in a detection zone for a prolonged period.

No Signal detection– a detection tool is triggered that is triggered by the absence of an audio signal from an audio device.

Line Crossing detection– a detection tool is triggered which is triggered when the trajectory of an object crosses a virtual line in a video camera's field of view.

Object appearance detection– a detection tool is triggered by the appearance of an object in a set area of a video camera's field of view.

Stopping detection– a detection tool is triggered by the cessation of motion in a set area of a video camera's field of view.

Noise detection– a detection tool which is triggered by an decrease in the signal/noise ratio below a set level.

Axxon Domain – a selected group of computers on which the server configuration of the *Axxon Next* software package is installed. Linking the servers in a group makes it possible to set up interaction between them, thus organizing a distributed system.

Detection zone – the area of a video image processed by a detection tool is triggered.

Interface cable - cable used to connect two or more devices together for data transfer.

Interface object - a system object used for interaction between the user and software (data input/output).

Client - designation for a personal computer on which Axxon Next software is installed (or will be installed) as a **Client**.
Designation for the graphical shell of the *Axxon Next* software package.

Slideshow – automatic switching of user layouts, or of viewing tiles in a single layout if working with standard layouts.

Licensing - regulating and setting the terms for usage of AxxonSoft software modules.

Detection zone – 1. the area of a video image processed by a detection tool is triggered.
2. a tool which allows the user to mark out an area of the video image which is not to be processed by a detection tool is triggered.

Microphone – 1. a source of audio signals.
2. a system object used to manage the parameters of audio signal reception.

Video surveillance monitor – an interface object used to manage the user interfaces of the Axxon Next software, e.g., layouts, viewing tiles, various panels and context menus, etc.

Viewing tile - interface object displaying the video stream coming from a certain video camera and enabling control of that video camera.

Dial panel – panel (part of the PTZ control panel) used to dial a preset.

Archive navigation panel – all interface objects used to work with an archive, e.g., timeline, list of alarm events, etc.

Control panel – panel made up of tabs accessible to the user, used to navigate from one group of interface objects to another.

Playback control panel – panel containing buttons to control playback of video recordings: Play, Pause, Go to next video recording, etc.

PTZ control panel – all interface objects used to control a certain PTZ device.

Layout control ribbon – panel containing tools to create, edit, and manage layouts.

PTZ device – a system object displaying the properties of an installed PTZ camera device.

Note

Also used to designate a physical device

The PTZ subsystem encompasses all the tools that provide for remote control of a PTZ device and the lens of a video camera.

The analytics subsystem encompasses all the tools that provide for automatic analysis of incoming video and audio data.

The Forensic Search in archive subsystem is a set of tools for searching video recordings in the archive by using video image metadata.

The Output subsystem encompasses all the tools that provide for the triggering of an execution device connected to the embedded Output port of a video camera or IP server when a detection tool is triggered (including one which processes the embedded Input of a video camera or IP server) is triggered.

The notification subsystem encompasses all the tools that provide for notification of the user about events which have occurred in the system.

Event registration subsystem – all the tools that provide for the collection of data about system events, processing, and its storage on media.

Pre-alarm recording is the period of pre-event recording that will be added to the beginning of an alarm event recording.

Preset – preprogrammed positioning of a PTZ device.

Software package – all software and hardware tools used together to build a security system.

Software module – a program or functionally complete component of a program used to perform a specific functional task (perform a user function).

Layout – preserved positioning of viewing tiles relative to each other.

Distributed system – a group consisting of several interacting Axxon Next servers (up to four) and clients (unlimited number). Axxon Next servers are linked within an Axxon Domain.

Output – 1 a physical device/electromechanical switch.
2. a system object that displays the properties of an installed Output.

Server – designation for a personal computer on which the **Server** configuration of Axxon Next software is installed (or will be installed).

Security system – a set of devices used for video surveillance, audio surveillance, and object recognition, all controlled by the Axxon Next software system.

The system log is a log containing system information on events, including system error entries.

Object tracking – a function which allows an operator to visually track the movement of objects in a camera's field of view.

Alarm flag – the flag symbol designating either the moment an alarm event began or a certain moment before the beginning of an alarm event.

Color coding - software-based graphical notification to a security system operator about the current status or operating mode of system objects (equipment, software modules).

Facial vector - mathematical representation of a facial image created upon face capture.

Captured faces - images detected on video by the facial detection tool.

Recognized faces - captured faces that reach a pre-defined degree of similarity against reference facial images.

Reference faces - pre-defined facial images to compare captured faces to.

10.2 Appendix 2. Known issues in the Axxon Next Software Package

10.2.1 Possible Errors During Installation

On page:

- [Error starting NGP Host Service](#)
- [Errors Connecting to the Postgres Database](#)
- [Error installing Drivers Pack](#)
- [Error installing DetectorPack](#)
- [Window OS 10 installation error](#)
- [An error occurred while installing on Windows with the language pack Norsk \(bokmål\)](#)
- [Error uninstalling Axxon Next on systems with Videoinspector installed](#)

10.2.1.1 Error starting NGP Host Service

If port 20111 is busy during installation of Axxon Next (for example, because of nethost.exe processes that have not been unloaded since removal of the previous version), an error message regarding the launch of NGP Host Service appears.

To continue installation, free up port **20111** and try again.

10.2.1.2 Errors Connecting to the Postgres Database

After installation of the Postgres database, the Axxon Next installer may quit prematurely. This situation may be associated with the inability of the installer to connect to the Postgres database, if the firewall is enabled. To prevent this, disable your firewall during installation.

Note

Disabling the firewall during installation can cause another problem: see [No signal from video cameras and failure to connect to other servers](#).

10.2.1.3 Error installing Drivers Pack

In some cases, you may encounter errors while installing Drivers Pack:

Installation failed because the Universal C Runtime is not installed. Please run Windows Update and install all required Windows updates(KB2999226). You can download the UCRT separately from here: 'https://support.microsoft.com/en-us/kb/2999226'

This can be solved by installing the Windows update [KB2999226](#).

10.2.1.4 Error installing DetectorPack

In some cases, you may encounter V2C Error while installing Detectorpack: HASP LM is not running Status Code: 37 0 4832 33.

To resolve it, do as follows:

Start the command line (Run as administrator).

1. Run the following sequence of commands: 1) **bcdedit -set LOADOPTIONS DISABLE_INTEGRITY_CHECKS 2) bcdedit -set TESTSIGNING ON.**
2. Reboot and make sure that the **hasplms** service is running.
3. Reinstall the driver [Sentinel HASP LDK - Windows GUI Run-time Installer](#).
4. Reinstall *Axxon Next*.

10.2.1.5 Window OS 10 installation error

When you install Axxon Next on Windows 10.0.17763 and up you may see the Create Recovery Archive error message.

To fix the error, do as follows:

1. Go to Control Panel → Clock and Region → Region → Administrative tab → Change System Locale
2. Deselect the checkbox **Beta: Use Unicode UTF-8 for worldwide language support**.

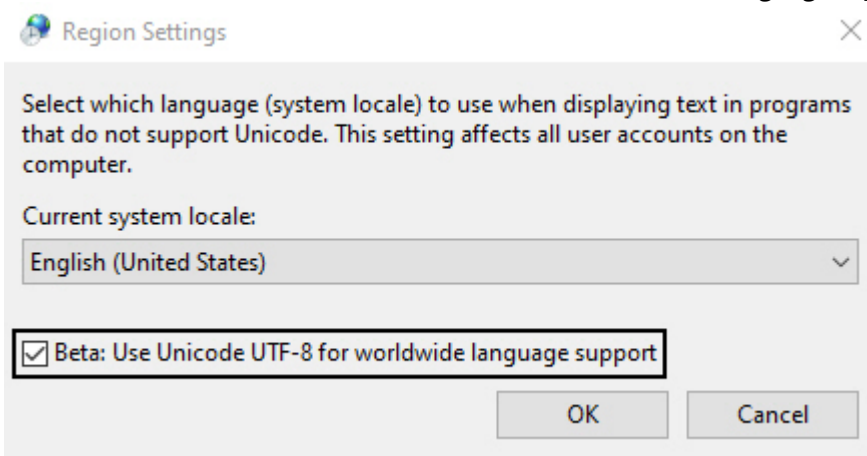

3. Reinstall *Axxon Next*.

10.2.1.6 An error occurred while installing on Windows with the language pack Norsk (bokmål)

Installing the Axxon Next server on Windows with the language pack Norsk (bokmål) is not possible due to incompatibility with PostgreSQL.

You must install Norsk Language Pack (Nynorsk).

10.2.1.7 Error uninstalling Axxon Next on systems with Videoinspector installed

In some cases, uninstalling Axxon Next may be impossible if Videoinspector is used.

For Axxon Next to work correctly, you are advised to first uninstall Videoinspector.

10.2.2 Possible Errors During Start-Up

10.2.2.1 The Client cannot be connected to the Server

If a "**Cannot find Server**" message appears after you connect to a Server, do the following:

1. Go to **Control Panel** -> **Regional Settings** -> **More**.
2. Change current language of non-Unicode applications to the one that is present in keyboard settings, and may appear in user name and folders.
3. Reboot the PC.

If a **Connection Error** message appears after you connect to a Server, do the following:

1. Go to **Local Security Policy interface**.
2. Select **Local Policies** -> **Security Settings**.
3. Turn off the following parameter: **System cryptography: use FIPS compliant algorithms for encryption, hashing, and signing**.

Launching the Axxon Next software program with client logging enabled can take a long time when the *ESET NOD32 Antivirus 4 Real-time file system protection* mode is on.

To solve this problem, add the Axxon Next installation folder and the folder with the client logs (<Letter of system disk>:\Users\<User>\Appdata\Local\AxxonSoft\AxxonNext\logs) to the list of exceptions in ESET NOD32 Antivirus 4.

10.2.3 Possible Errors During Operation

On page:

- [All video cameras or archives stop working once the license maximum is reached](#)
- [No signal from video cameras and failure to connect to other servers](#)
- [Incorrect display of Client interface elements](#)
- [Server error on Windows Server 2012](#)
- [Emergency shutdown of the Client on Windows 8.1](#)
- [Error creating new archives even when license restriction on total size is observed](#)
- [The Axxon Next VMS operation along with Windows Defender software](#)
- [Upper panel display problem](#)
- [High CPU load during OpenGL software emulation](#)
- [Performance of Axxon Next when working with NetLimiter 2](#)
- [Exported videos' playback in Movies and TV application](#)

10.2.3.1 All video cameras or archives stop working once the license maximum is reached

If the activation key allows the use of a smaller number of video cameras than the amount used at the moment on the system, all of the video cameras will cease to function with the system. To resume operation, remove the objects corresponding to the excess number of video cameras and restart the server.

Note

Restart the Server through the Start menu as follows:

1. All Programs -> Axxon Next -> Shut Down Server
2. All Programs -> Axxon Next -> Start Server

Similarly, if an activation key allows using archives with a total size of an amount less than the current one, you are advised to correct the archive size to the required amount and then restart the server.

10.2.3.2 No signal from video cameras and failure to connect to other servers

If the Windows Firewall (or firewall of other manufacturers) was disabled during installation of Axxon Next, Axxon Next services and applications will not be automatically added to the list of firewall exceptions.

After you turn on the firewall, you may see no signal from cameras in both main and web Client, and no possibility to connect to other Servers.

To solve this problem, add the following applications to the firewall exceptions: Apphost.exe, NetHost.exe, AxxonNext.exe, and LicenceTool.exe.

Note

If ESET NOD32 Smart Security 6 anti-virus software is used, disable Personal firewall

10.2.3.3 Incorrect display of Client interface elements

Client interface elements may be distorted on systems with some versions of GeForce drivers (such as 327.23, 337.88) installed.

In some cases this problem is solved by disabling stream optimization for the axxonnext.exe process:

1. Run **Control panel -> NVIDIA control panel -> 3D parameters -> Software settings**.
2. Click the **Add** button and select the axxonnext.exe file (*<Axxon Next installation directory>/bin*).
3. Set the **Off** parameter for the **Threaded optimisation** function.
4. Click the **Apply** button.

If this solution does not eliminate the problem, then install an older driver for the graphics card.

10.2.3.4 Server error on Windows Server 2012

You may experience errors when running the server on Windows Server 2012. To fix the errors:

1. Open the registry path HKEY_LOCAL_MACHINE\System\CurrentControlSet\Control\Session Manager\SubSystems\.
2. Find the **Windows** parameter and change its value as follows: in the string "SharedSection = 1024,20480, **768**", replace **768** with **4096**.
3. Save the changes and restart the computer.

10.2.3.5 Emergency shutdown of the Client on Windows 8.1

You may see the Client shutting down on Windows 8.1 with an error: " The name of the failed module: KERNELBASE.dll Exception code: 0xe0434352 ".

In this case, please contact Microsoft support.

10.2.3.6 Error creating new archives even when license restriction on total size is observed

If the user creates archives at the same time (in other words, without applying changes) while deleting some existing archives, creation of archives may be forbidden even if the total archive size does not exceed the amount of the license restriction.

Note

This happens because when verifying the license restrictions, the size of created archives is calculated based on the total size the last time when changes were applied

To regain the ability to create new archives in such situations, the user must first delete unnecessary archives and apply changes.

10.2.3.7 The Axxon Next VMS operation along with Windows Defender software

If you have *Windows Defender* software installed in your system, some problems may occur while accessing and saving data to Archive files, as well as significant slowing down of MomentQuest searches.

As a workaround, you can either disable *Windows Defender* or add AppHost.exe, AppHostSvc.exe and vfs_format.exe to the exceptions list.

10.2.3.8 Upper panel display problem

In some cases, the Client may display the upper panel erratically,

If you encounter such a problem, please install the most recent version of [Intel graphics subsystem](#) drivers.

10.2.3.9 High CPU load during OpenGL software emulation

If your computer's graphics card does not meet OpenGL requirements (see [Limitations of the Axxon Next Software Package](#)), OpenGL can be emulated in software.

But this may place a high load on the CPU.

10.2.3.10 Performance of Axxon Next when working with NetLimiter 2

If *NetLimiter 2* is installed in the system, there may be a significantly increased load on the processor when working with *Axxon Next*.

This problem is resolved by removing *NetLimiter 2*.

10.2.3.11 Exported videos' playback in Movies and TV application

Due to the lack of G.711 and G.726 codecs support in Windows 10's "Movies and TV" app, exported footage playback is video only.

You can use alternative video viewer applications to obtain the full playback.

10.3 Appendix 3. Assigning of the domain takes place when the Axxon Next server is installed

The Windows OS will create two accounts when the Axxon Next software package is installed using a **Client and Server** type of configuration.

1. An account with administrator rights which is used by the Axxon Next file browser. The name of this account is set during installation of Axxon Next (see [Installation](#)).
For Axxon Next to function correctly, this account must have Windows administrator rights. If the account is a domain user account, you must also add the account to the **Users** and **Power Users** groups.

Note

The file browser helps to navigate through the Server's file system (such as when choosing disks for log volumes)

The account can also be used for configuring access rights to the hard disk.

2. Axxonpostgres – an account under which the log data database service is started.

Note

A log database (Postgres) is used for storing system events

10.4 Appendix 4. Using Axxon Next with anti-virus software

On page:

- [NOD32](#)
- [ESET Smart Security](#)
- [AVG](#)
- [DrWeb](#)
- [McAfee SAAS](#)

Depending on the anti-virus software that you use, when you install, start, and use Axxon Next, your anti-virus software may ask for permission for the software components to perform Internet access.

It is recommended that you allow these components to do so for proper functioning of the application.

Recommendations for specific anti-virus programs are given below.

10.4.1 NOD32

When using NOD32 Antivirus, it is strongly recommended to either disable the Web Access Protection service or to add the IP addresses of IP cameras to the list of exceptions for anti-virus scanning.

See also section [Possible Errors During Start-Up](#).

10.4.2 ESET Smart Security

If you use ESET Smart Security, select automatic mode with Firewall exceptions and add the remote servers to the exceptions by creating network rules (for help with creating these rules, refer to the official user guide for the anti-virus software).

10.4.3 AVG

When using AVG on a configuration with many video cameras, it is strongly recommended to add the IP addresses of IP cameras to the list of exceptions. Otherwise, the avg.exe process may severely slow down the CPU. This action can be performed only in the paid version of AVG.

When installing Axxon Next, allow the NetHost.exe and ngpsh.exe processes to run.

10.4.4 DrWeb

If you use DrWeb anti-virus software, perform the following actions before installing Axxon Next:

1. Disable automatic start of the DrWeb firewall.
2. In the proactive protection settings, select the option to use custom settings and enable the following options:

- a. Allow low-level disk access
 - b. Allow system services
 - c. Allow loading drivers
 - d. Allow user drivers
 - e. Allow Winlogon shell parameters
3. In the SpiDer Gate settings, add the apphost.exe and AxxonNext.exe processes to the list of exceptions for scanning of incoming traffic. If possible, it is recommended to disable scanning of incoming and outgoing traffic.

10.4.5 McAfee SAAS

For correct functioning of Axxon Next distributed configurations and remote clients, you must disable the Firewall Protection component in McAfee SAAS.

Note

It is not necessary to disable this component if your configuration contains a single server and a local client.

10.5 Appendix 5. Using CH VM-Desktop USB multifunction controllers with Axxon Next

CH VM-Desktop USB multifunction controllers offer a range of input controls:

- Three-axis joystick for PTZ and digital zoom control (**J1** and **J2**)
- Jog/shuttle dial (**J3** and **J4**)
- 27 keys
- 10 number keys
- * key
- # key
- Programmable keys **C1** to **C13** (keys cannot be remapped in Axxon Next)
- Two additional keys (**B1** and **B2**)

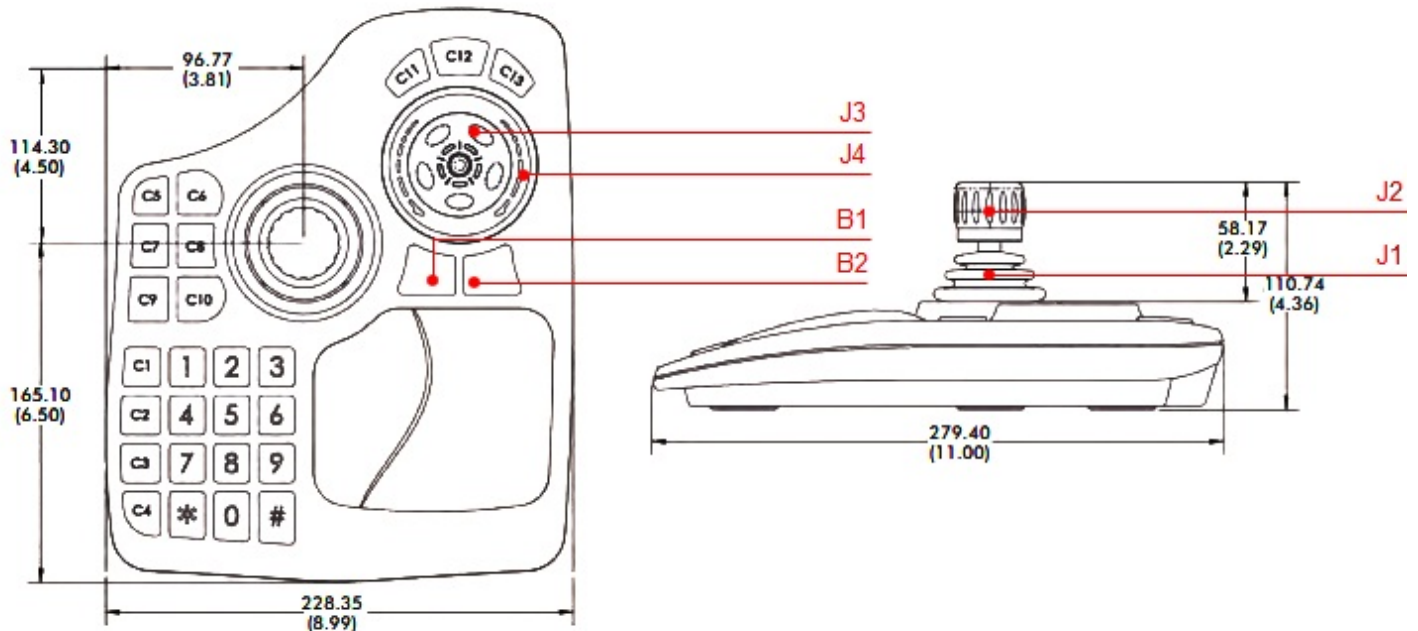

The multifunction controller can be used to operate Axxon Next on the active monitor.

Note

The active monitor is either the main one (if all additional monitors are inactive or not connected) or an additional one, if the additional monitor is active (see [Configuring Interfaces on a Multi-Monitor Computer](#)).

The active monitor can be selected only by using the mouse. If no mouse is present, the multifunction controller will work on the main monitor only.

A description of key functions is given in the table.

Key	When available	Function
J1	Always	PTZ control for the selected camera. If the selected camera does not support PTZ control, the action is ignored.
J2	Always	Optical zoom control for the selected camera. If the selected camera does not support PTZ control, the action is ignored.
J3 (rotate counterclockwise)	Archive mode	Go to previous frame. If playback is active, the action is ignored.
J3 (rotate clockwise)	Archive mode	Go to next frame. If playback is active, the action is ignored.
J4 (rotate counterclockwise)	Archive mode	Go to previous video fragment.
J4 (rotate clockwise)	Archive mode	Go to next video fragment.
J4	Live Video mode	Iris control for the selected camera.
1	Live Video mode	Start/stop patrol mode.
2.3	Live Video mode	Focus control for the selected camera.
* n #	Always	Select a camera in a layout. n is the number of the camera to be activated via the number keys. If the camera with the relevant number is not in the current layout, a search is performed for the minimum layout containing the camera; the minimum layout is then displayed. If no such layout exists, a layout with one camera is created.
# n #	Always	Go to layout. n is the layout to be activated via the number keys; the number corresponds to the order in which the layout appears in the list.
C10	Always	Clear number. If the operator did not finish typing the number of a camera or layout (the # key was not pressed), pressing the C10 key clears the previously entered number.
C1	Alarm Management mode	Accept alarm with False Alarm resolution.

C2	Alarm Management mode	Accept alarm with Non-Critical Alarm resolution.
C3	Alarm Management mode	Accept alarm with Critical Alarm resolution.
C4	Always	Manually initiate an alarm and go to Alarm Management mode. Go to Alarm Management mode if an alarm has been previously initiated.
C5	Always	Increase size of layout cell
C6	Always	Reduce size of layout cell
C7	Always	Go to previous layout in the list
C8	Always	Go to next layout in the list
C11	Archive mode	Slow down playback
C12	Archive mode	Start/pause video playback
C13	Archive mode	Speed up playback
B2	Archive mode, Alarm Management mode	Go to Live Video mode (without alarm classification)
B2	Live Video mode	Go to Archive Mode
C9	Archive mode	Open/hide calendar
B1, B2	Open calendar	Cycle through calendar elements (equivalent to pressing the tab key) days of month - hours - minutes - seconds - am/pm (B2 key) and in reverse (by pressing the B1 key)
J3	Open calendar	Navigate by days and set hours, minutes, seconds, and AM/PM
J4	Open calendar	Navigate by months

10.6 Appendix 6. Hotkeys in Axxon Next

Axxon Next comes with the following default hotkeys:

Function	Hot key
Global	
<u>General</u>	
Activate panel of cameras	F4
Activate panel of configuration	F5
Activate panel of layouts	F2

Activate panel of video walls	F3	
Select item of menu and panels, click Save, Apply, OK	Enter	
Navigation. Down	Down	
Navigation. Left	Left	
Navigation. Right	Right	
Navigation. Up	Up	
Open menu of current layout	F1	
Open panel with list of devices	F7	
Open alarm panel	F6	
Hide menu/panel, click Cancel	Esc	
Lock application	Ctrl + Alt + L	
Remove current value	Delete	
Digit 1	D1	
Digit 9	D9	
<u>Layouts</u>		
Camera selection in current layout	Ctrl + N	
Select monitor by number	Shift + N	
Select layout by number	Alt + N	
Select the previous* camera in current layout cell		
Select the next* camera in current layout cell		
Navigation the cameras, upward shift	Alt + Up	
Navigation the cameras, left shift	Alt + Left	
Navigation the cameras, downward shift	Alt + Down	
Navigation the cameras, right shift	Alt + Right	
Move to the previous layout	Shift + Left	
Move to the next layout	Shift + Right	
Increase layout cell	Ctrl + Add (+)	
Decrease layout cell	Ctrl + Subtract (-)	
* by ID		
Live Video display mode		
<u>Videocamera</u>		

Open menu of selected camera and select item	F9	
Switch to archive mode	Ctrl + Tab	
Switch to alarm classification mode	Ctrl + R	
Switch to search in archive mode	Ctrl + F	
Arm	Ctrl + A	
Disarm	Ctrl + D	
<u>PTZ</u>		
Move up	NumPad8	
Move left	NumPad4	
Move down	NumPad2	
Move right	NumPad6	
Close iris	Next	
Focus far	End	
Open iris	PageUp	
Patrolling	Multiply (*)	
Focus near	Home	
Zoom in	NumPad9	
Zoom out	NumPad3	
Archive		
Open menu of selected camera and select item	Ctrl + E	
Pause / Play	Ctrl + Space	
Switch to Time Compressor mode	Ctrl + T	
Go to the previous video clip	Ctrl + Shift + Left	
Go to the previous frame	Ctrl + Left	
Go to the next video clip	Ctrl + Shift + Right	
Go to the next frame	Ctrl + Right	
Show calendar	F8	
Increase playback speed	Ctrl + Up	
Reduce playback speed	Ctrl + Down	
TimeCompressor		
Pause / Play	Ctrl + Space	
Move home	Ctrl + B	

Increase number of objects	Ctrl + Up	
Decrease number of objects	Ctrl + Down	
Alarms		
Go to the previous frame	Ctrl + Left	
Go to the next frame	Ctrl + Right	
Resolution False alarm	Ctrl + D3	
Resolution Non-critical alarm	Ctrl + D2	
Resolution Critical alarm	Ctrl + D1	
Increase playback speed	Ctrl + Up	
Reduce playback speed	Ctrl + Down	

10.7 Appendix 7. Automated configuration backup and restore

You can use the ngpsh.exe utility and json commands to back up and restore your system configuration.

Attention!

These configuration backups are incompatible with those created with the Backup and Configuration Recovery utility, and vice versa.

To create a configuration backup:

1. Use Windows command line to access the <Axxon Next installation directory>\AxxonNext\binfolder.
2. Execute the following command:

```
ngpsh.exe backup backupJson [path_to_backup_folder] [node_name] [local] [shared]
[license] [tickets]
```

Where

Parameter	Description
path_to_backup_folder	Required parameter. Specify a folder to save the configuration backup to. You have to use two "\" characters in the path.
node_name	Required parameter. Name of a Server whose configuration you want to save.
local	Add it, if you need to save the local configuration for this Server: all created objects along with their parameters, links and changes' histories.
shared	Add it, if you need to save the global configuration for an Axxon domain: users, layouts, etc.
license	Add it, if you need to save a license.

Parameter	Description
tickets	Add it, if you need to save the Axxon domain structure.

An example:

```
ngpsh.exe backup backupJson c:\\backups Server1 local
```

To restore a configuration from a backup:

```
ngpsh.exe backup restoreJson [path_to_backup_file] [node_name] [local] [shared]
[license] [tickets] [deleteLocal] [deleteShared]
```

Where

Parameter	Description
deleteLocal	Add it, if you need to clear the local configuration from objects not present in the backup copy.
deleteShared	Add it, if you need to clear the global configuration from objects not present in the backup copy.

An example:

```
ngpsh.exe backup restoreJson c:\\backups\\Server1.json local
```

10.8 Appendix 8. Configuring and operating the Axxon Next in Linux OS

10.8.1 Linux OS supported versions

Axxon Next supports all 64-bit installation packages based on Debian 9 and Debian 10.

Note

It is recommended to use Ubuntu 18.

10.8.2 Axxon Next limitations in Linux OS

The following features are currently not available in Axxon Next operating on Linux OS:

1. Immersive mode (see [Immersive mode](#)).
2. POS devices (see [Configuring POS devices](#)).
3. Intel Quick Sync Video (see [Hardware-based decoding with Intel Quick Sync Video](#)).
4. Adaptive video stream (see [Configuring an Adaptive Video Stream](#)).
5. Upgrading Servers within a cluster via the supervisor web interface (see [Upgrading Servers within a cluster](#)).
6. Upgrading remote Clients on any OS via Server on Linux OS (see [Automatic update of a remote Client](#)).
7. POS devices (see [Configuring POS devices](#)).

8. Axxon Next Tray Tool.

10.8.3 Installing sudo

The sudo software is used for installing and configuring *Axxon Next*.

If it is not included in the OS distribution package, then to install it and add the *user*, it is necessary to run the following commands in the root mode:

```
apt-get install sudo
usermod -aG sudo user
reboot
```

10.8.4 Installing the Axxon Next in Linux OS

10.8.4.1 Installing the Axxon Next Server in Linux OS

10.8.4.1.1 Installing from repository

Installation from the repository is performed automatically including all the system components.

For this purpose, do the following:

1. Consequently execute the commands:

```
echo 'deb http://download.axxonsoft.com/debian-repository stretch main' | sudo tee -a /
etc/apt/sources.list.d/axxonsoft.list

echo 'deb http://download.axxonsoft.com/debian-repository stretch backports/main' | sudo
tee -a /etc/apt/sources.list.d/axxonsoft.list

wget --quiet -O - "http://download.axxonsoft.com/debian-repository/
info@axxonsoft.com.gpg.key" | sudo apt-key --keyring /etc/apt/trusted.gpg.d/axxonsoft.gpg
add - && sudo apt-get update
```

Note

If the distributives based on Debian 10 are used, it may be necessary to install additional packages:

```
apt-get install wget
apt-get install gnupg
```

2. To install a Server, run the following command:

```
sudo apt-get install axxon-next
```

To install a FailOver Server, run the following command:

```
apt-get install axxon-next-raft
```

Attention!

It is not allowed to simultaneously install a regular Server and a FailOver Server.

During the installation, the installer will request the name of the Axxon-domain for the Axxon Next server. If you leave this field blank, you can specify it on the client at the first connection.

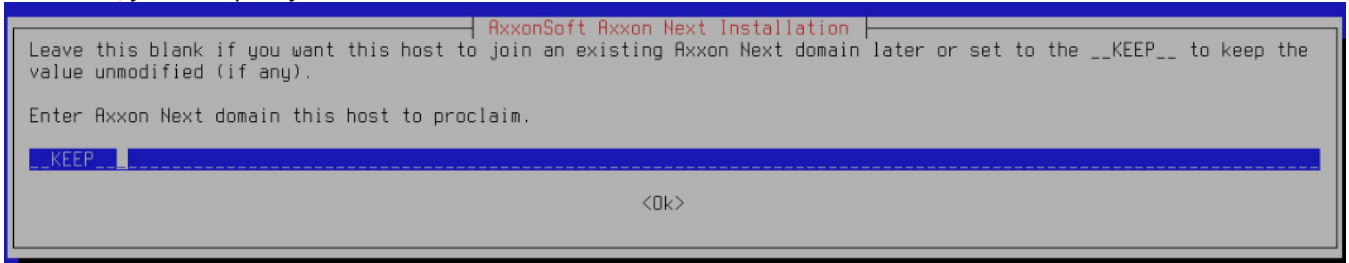

10.8.4.1.2 Manual installation

To install the Axxon Next Server manually, do the following:

1. Add the repositories by sequentially executing the following commands:

```
echo 'deb [arch=amd64] http://download.axxonsoft.com/debian-repository stretch main' |
sudo tee -a /etc/apt/sources.list.d/axxonsoft.list
echo 'deb [arch=amd64] http://download.axxonsoft.com/debian-repository stretch backports/
main' | sudo tee -a /etc/apt/sources.list.d/axxonsoft.list
wget --quiet -O - "http://download.axxonsoft.com/debian-repository/
info@axxonsoft.com.gpg.key" | sudo apt-key --keyring /etc/apt/trusted.gpg.d/axxonsoft.gpg
add - && sudo apt-get update
```

2. To download the packages, run one of the following commands:
 - a. Server only:

```
sudo apt-get install -d axxon-next
```

- b. Server and Client:

```
sudo apt-get install -d axxon-next-client
```

By default, the files are downloaded to the `/var/cache/apt/archives` folder. If it is necessary to download the files to another folder, run the following command:

```
apt-get install -d axxon-next -o=dir::cache=/home/user/Downloads/
```

In this case, the packages will be downloaded to the `/home/user/Downloads` folder.

Attention!

If you plan to install the downloaded packages on another computer with no Internet, then the OS version on that computer should match the OS version on which the packages were downloaded.

3. To install the previously downloaded packages, execute the command:

```
sudo dpkg -i /home/user/Downloads/*.deb || sudo apt-get install -f -y
```

where

user - user name;

Downloads - folder with downloaded packages.

Package examples...

Example of packages required to install the server side:

```
axxon-drivers-pack_3.46_amd64.deb
axxon-detector-pack_3.1_amd64.deb
axxon-next-core_4.5.0_amd64.deb
axxon-next_4.5.0_all.deb
```

Example of packages required to install the Server in the Failover mode:

```
axxon-drivers-pack_3.46_amd64.deb
axxon-detector-pack_3.1_amd64.deb
axxon-next-core_4.5.0_amd64.deb
axxon-next-raft_4.5.0_amd64.deb
```

Example of packages required for the Server and Client installation type:

```
axxon-drivers-pack_3.46_amd64.deb
axxon-detector-pack_3.1_amd64.deb
axxon-next_4.5.0_all.deb
axxon-next-core_4.5.0_amd64.deb
axxon-next-client-bin_4.5.0_amd64.deb
axxon-next-client_4.5.0_all.deb
```

Attention!

The folder should not contain other packages.

It is not allowed to simultaneously install the normal Server and the Failover Server.

During the installation, the installer will request the name of the Axxon-domain for the Axxon Next server. If you leave this field blank, you can later specify it on the Client at the first connection.

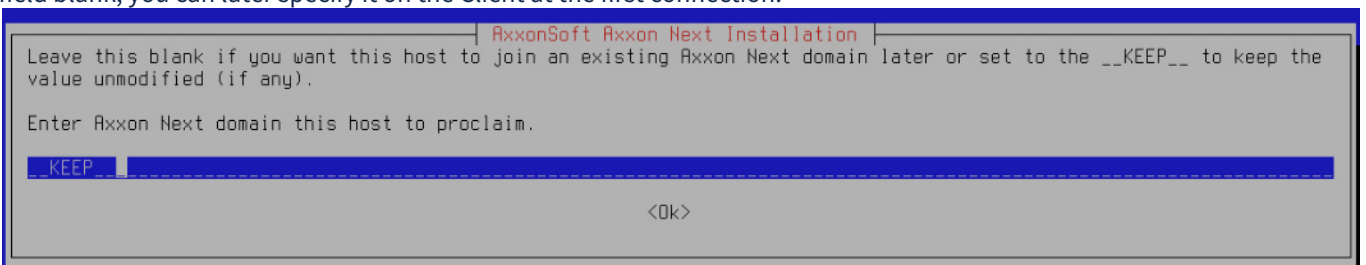

4. If necessary, you can change the Server configuration after installation (see [Axxon Next Server configuration change](#)).

Installation is complete.

You can install the Detector Pack and Driver Pack from the repository. To do this, sequentially execute the following commands:

```
sudo apt-get install axxon-drivers-pack
sudo apt-get install axxon-detector-pack
```

Attention!

The Detector Pack and Driver Pack must be installed from the repository before installing the main part of Axxon Next. If the Detector Pack and Driver Pack were installed from the repository, it is necessary to remove them from the folder with downloaded installation packages.

10.8.4.2 Installing the Axxon Next Client in Linux OS

To install the Axxon Next Client in Linux OS, do the following:

Attention!

The Client installation is possible only after getting the same Server version installed (see [Installing the Axxon Next Server in Linux OS](#)).

1. For the automatical installation from the repository:
 - a. Add the repositories by sequentially executing the following commands:

```
echo 'deb [arch=amd64] http://download.axxonsoft.com/debian-repository stretch main'
| sudo tee -a /etc/apt/sources.list.d/axxonsoft.list
echo 'deb [arch=amd64] http://download.axxonsoft.com/debian-repository stretch
backports/main' | sudo tee -a /etc/apt/sources.list.d/axxonsoft.list
wget --quiet -O - "http://download.axxonsoft.com/debian-repository/
info@axxonsoft.com.gpg.key" | sudo apt-key --keyring /etc/apt/trusted.gpg.d/
axxonsoft.gpg add - && sudo apt-get update
```

- b. If you use Ubuntu 20.04, then install the mono-complete from the stretch repository:

```
apt-get install mono-complete -t stretch
```

- c. Run the command:

```
sudo apt-get install axxon-next-client
```

- d. During installation, it will be necessary to specify the maximum size of log files in megabytes and log level.

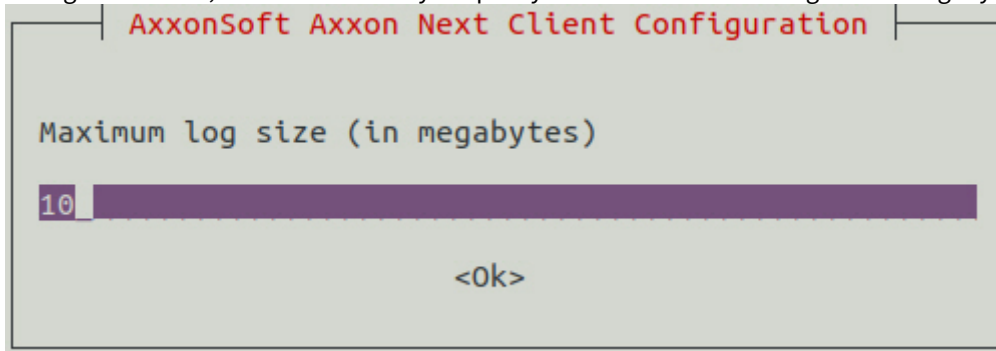

```
AxonSoft Axxon Next Client Configuration

Log level for Axxon Next Client

OFF
ERROR
WARN
INFO
DEBUG
TRACE
ALL

<Ok>
```

Note

The specified value can be changed (see [Configuring the Axxon Next Client logging parameters on Linux OS](#)). To do this, execute the command:

```
sudo dpkg-reconfigure axxon-next-client
```

2. For the manual installation:
 - a. Go to the downloaded deb-packages folder.
 - b. Execute the following commands:

```
sudo dpkg -i axxon-next-client-bin_4.5.1.9763_amd64.deb
sudo dpkg -i axxon-next-client_4.5.1.9763_all.deb
```

where 4.5.1.9763 is the version and build number.

After the installation is complete, the Client icon will be displayed in the application menu.

Attention!

It is not recommended to run the Client as root user or with root permissions.

By default, at the first Client start, the OS interface language will be used. To change the language of the Client's interface at the first start, do the following:

1. Run the following command.

```
sudo dpkg-reconfigure axxon-next-client
```

2. Select the required language.

```

AxxonSoft Axxon Next Client Configuration

Default locale at first start of Axxon Next Client by each OS user

[OS Language]
ar
bg
cs
da
de
eL-GR
en
es
fr
he
hr
hu
it
ja
ko
lt
nl
pl
pt-BR
ru
sk
sr
tr
uk
zh-Hant
zh-SG

<Ok>

```

Note

This should be configured separately for each OS user.

Attention!

After you run the Client, select the interface language for the next launches in the settings (see [Selecting the interface language](#)).

10.8.4.3 Configuration and log folders

The following folders are being used by default:

1. Logs and Client configuration:

```
/home/USER/.local/share/AxxonSoft/
```

2. Server configuration:

```
/opt/AxxonSoft/AxxonNext/
```

10.8.4.4 Axxon Next Server launch using Docker

To run the Axxon Next Server using Docker, do the following:

1. Install Docker (see [Docker installation](#) and [Specifics of Docker installation on Ubuntu](#)).
2. Create the Axxon Next container (see [Creating the Axxon Next container](#)).

Minimum requirements to run Axxon Next using Docker on Ubuntu:

- Dual core processor;
- 4 GB RAM;
- 200 GB HDD.

10.8.4.4.1 Docker installation

To install the Docker, do the following:

1. Execute the command in the root mode.

```
sudo apt-get install \
  apt-transport-https \
  ca-certificates \
  curl \
  gnupg2 \
  software-properties-common
```

2. Add CPG key and fingerprints.

```
curl -fsSL https://download.docker.com/linux/debian/gpg | sudo apt-key add -
sudo apt-key fingerprint 0EBFCD88
```

3. Add the official repository to the source.list.

```
sudo add-apt-repository \
  "deb [arch=amd64] https://download.docker.com/linux/debian \
  $(lsb_release -cs) \
  stable"

sudo apt-get update
```

4. Install the Docker-ce and docker-compose (see <https://github.com/docker/compose/releases>).

```
sudo apt-get install docker-ce docker-compose
```

5. Add the system user to the docker group.

```
sudo adduser user docker
```

6. Log in the system under this user.
7. Install Mercurial.

```
sudo apt-get install mercurial
```

8. Add string to the hgrc file.

```
sudo nano ~/.hgrc
```

```
[ui]
tls = False
```

- Clone the repository.

```
hg clone https://bitbucket.org/Axonsoft/axxonnext.docker /home/user/axxonnext.docker
```

Update the repository, if necessary.

```
cd axxonnext.docker
hg pull -u
```

10.8.4.4.2 Specifics of Docker installation on Ubuntu

To install Docker on Ubuntu, do the following:

- Update the lists.

```
sudo apt-get update
```

- Install the packages to use the repository via HTTPS

```
$ sudo apt-get install \
apt-transport-https \
ca-certificates \
curl \
software-properties-common
```

- Add the official Docker GPG key.

```
$ curl -fsSL https://download.docker.com/linux/ubuntu/gpg | sudo apt-key add
```

- Set up the repository:

- for x86_64 / amd64 architecture:

```
$ sudo add-apt-repository \
"deb [arch=amd64] https://download.docker.com/linux/ubuntu \
$(lsb_release -cs) \
stable"
```

- for armhf architecture:

```
$ sudo add-apt-repository \
"deb [arch=armhf] https://download.docker.com/linux/ubuntu \
$(lsb_release -cs) \
stable"
```

5. Update the lists.

```
sudo apt-get update
```

6. Install the docker-ce.

```
sudo apt-get install docker-ce
```

7. Check the current version of docker-compose and upgrade it to the latest version, if necessary.

```
sudo curl -L https://github.com/docker/compose/releases/download/1.21.2/docker-compose-  
`uname -s`-`uname -m` -o /usr/local/bin/docker-compose
```

8. Set the access permissions.

```
sudo chmod +x /usr/local/bin/docker-compose
```

9. Check the installation and version of docker-compose.

```
docker-compose --version
```

10. Add the user to Docker.

```
sudo usermod -aG docker user
```

11. Install the Mercurial.

```
sudo apt-get install mercurial
```

12. Add to the hgrc file

```
sudo nano ~/.hgrc
```

the following:

```
[ui]  
tls = False
```

13. Clone the repository.

```
hg clone https://bitbucket.org/Axxonsoft/axxonnext.docker /home/pc/axxonnext.docker
```

14. Update the repository if necessary.

```
cd axxonnext.docker  
hg pull -u
```

15. Restart the OS.

```
sudo reboot
```

10.8.4.4.3 Creating the Axxon Next container

To create the Axxon Next container, do the following:

1. Copy the Axxon Next, Detector Pack and Driver Pack deb-packages into the folder `~/axxonnext.docker/next/build/`.
2. Go to the folder `~/axxonnext.docker/next`

```
cd ~/axxonnext.docker/next
```

3. Execute the command.

```
./axxon-next.sh build
```

The Axxon Next container build is going to start.

4. To view the list of the built-up containers, execute the following command after the operation is complete.

```
./axxon-next.sh list
```

10.8.4.4.4 Working with the Axxon Next container

- The list of containers.

```
./axxon-next.sh list
```

- Launching the container.

```
./axxon-next.sh start 4.3.2.37
```

- Viewing the container status.

```
./axxon-next.sh status
```

- Stopping the container.

```
./axxon-next.sh stop
```

- Collecting the system data.

```
./axxon-next.sh support
```

The file will be saved in the `~/axxonnext.docker/next/data/` directory.

- Viewing the installed packages version.

```
./axxon-next.sh versions
```

10.8.4.5 Updating the Axxon Next software in Linux OS

To update the Axxon Next software from the repository, it is necessary to execute the following commands in the **root** mode:

```
sudo apt-get update
sudo apt-get upgrade
```

To update the Axxon Next software from the folder, do the following:

1. Go to the folder with the downloaded packages.
2. Execute the following command:

```
sudo dpkg -i *
```

Attention!

After the update is completed, it is necessary to check the access rights of the archive file and the folder where it is stored.

The **ngp** user should be specified as the owner of both the file and the folder.

10.8.4.6 Uninstalling the Axxon Next software in Linux OS

To uninstall the Axxon Next but save the configuration, run the following command:

```
sudo apt-get remove axxon-next*
```

To completely remove the Axxon Next, run the following command:

```
sudo apt-get --purge --auto-remove remove axxon-next*
```

10.8.5 Moving the Axxon Next configuration from Windows OS to Linux OS

To transfer Axxon Next configuration from Windows OS to Linux OS, do the following:

1. Create the backup configuration in Windows OS (see [Backing up a configuration](#)).
2. Execute the following command in Linux OS:

```
sudo dpkg-reconfigure axxon-next
```

Attention!

The Server in Linux OS must belong to some Axxon-domain.

The following window will be displayed.

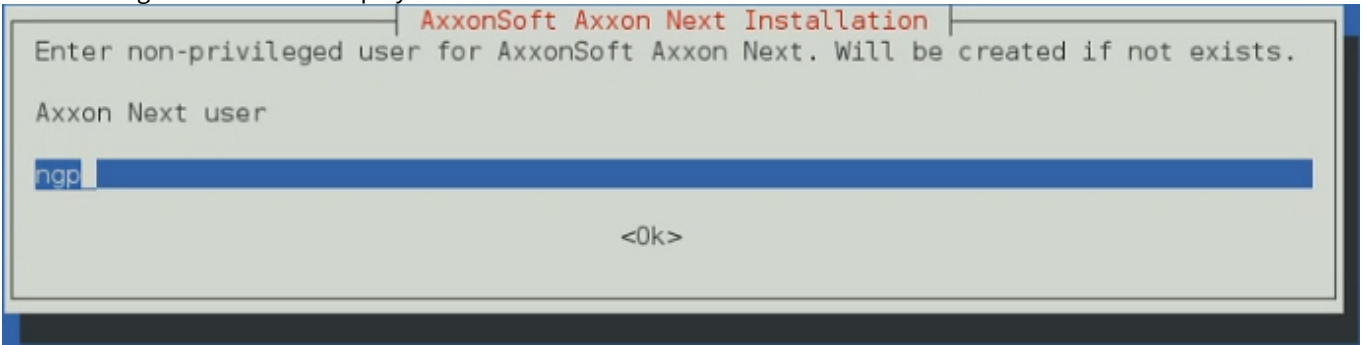

3. Press the Enter button several times until the Server node name change window is displayed.

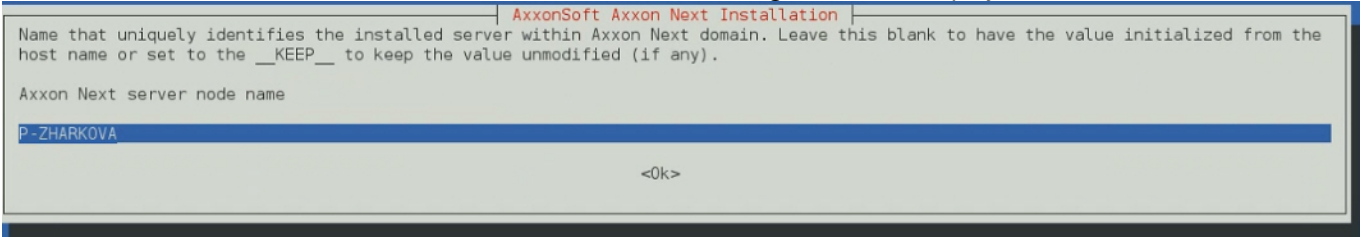

4. Enter the Server node name which is used in Windows OS.
5. Run the backup and configuration recovery utility (see [Backup and restore utility](#)) and select the specified Server on its launch.
6. Restore the configuration by selecting the saved backup.
7. Deactivate the license (see [Deactivating a license](#)) and distribute the license file again (see [Activation by applying license file](#)).

10.8.6 Starting and stopping the Axxon Next Server in Linux OS

Server start:

```
sudo service axxon-next start
```

Server stop:

```
sudo service axxon-next stop
```

Server restart:

```
sudo service axxon-next restart
```

Server status check:

```
sudo service axxon-next status
```

10.8.7 Archive creation features in Linux OS

10.8.7.1 Archive as a disk creation features in Linux OS

To allocate the disk for recording, execute the command in the root mode.

```
sudo su
```

```
fdisk -l
```

where

- /dev/sda - the first physical disk;
- /dev/sda**1** - the first section of the first physical disk;
- /dev/sda**2** - the second section of the first physical disk;
- dev/sdb - the second physical disk.

To delete the disk section, do the following:

1. Go to the disk where it is necessary to delete a section.

```
fdisk /dev/sdb
```

2. Delete the section.

```
d
```

3. Specify the section number.

```
2
```

4. Save the changes.

```
w
```

To create a section, do the following:

1. Go to the disk where it is necessary to create a section.

```
fdisk /dev/sdb
```

2. Create the section.

```
n
```

3. Specify the section: primary (p) or extended (e).

```
p
```

4. Specify the section number.

```
1
```

5. Specify the section size. G - gigabytes, M - megabytes, K - kilobytes.

```
+5G
```

6. . Save the changes.

```
w
```

To create the archive as a disk, do the following:

1. Create a new archive in the Axxon Next Client (see [Creating a local archive](#)).
2. Select the archive volume.
3. Specify the path to section in the address window. For example: /dev/sdb1. If it is required to use the whole disk as an archive, specify the /dev/sdc, /dev/sdd and so on.
4. Set the **Format** checkbox and click the **Apply** button.

Attention!

At this point you cannot change the archive size.

10.8.7.2 Archive as a file creation features in Linux OS

By default, in Linux OS the **ngp** user has rights to record only in the /opt/AxxonSoft/AxxonNext/ directory.

To create an archive in another directory, do the following:

1. Create a folder with write permissions.

```
sudo mkdir -m755 /home/archive
```

2. Change the folder owner to **ngp** user.

```
sudo chown -R ngp:ngp /home/archive/
```

3. Check the permissions on created folder.

```
ls -lt /home/
```

If there is a string with the ngp user permissions in the result, it is now possible to create an archive as a file in this directory.

```
drw-r--r--  2 ngp   ngp   4096 aug.  8 15:18 archive
```

10.8.7.3 Features of archives with ext and xfs file systems

When you work with archives (both local and network) on ext and xfs file systems, take into account the following features:

1. When you create an archive (see [Creating Archive](#)), the displayed free disk space is calculated based on the actual used space.

Note

For example, the disk size is 60 GB, and a 10 GB archive is created on it, but it is only 1 GB full.
When you try to create a second archive on this disk, 59 GB of free space will be displayed, not 50 GB.

2. Availability of the entire archive file size is not guaranteed in cases when other files run out of available space.

Note

Due to the ext and xfs file systems features, it is possible to create archives whose total size exceeds the free disk space.

Attention!

In such cases, it is necessary for the system administrator to control the free disk space.

10.8.8 Axxon Next Server configuration change

To change the Server configuration, do the following:

1. Execute the following command.

```
sudo dpkg-reconfigure axxon-next
```

2. Enter the Axxon-domain ID to which the Server should be added. To skip this step, press the Enter button.

```
AxxonSoft Axxon Next Server Configuration
Leave this blank if you want this host to join an existing Axxon Next domain later or set to the __KEEP__ to keep the value unmodified (if any).
Enter Axxon Next domain this host to proclaim.
KEEP
<Ok>
```

3. Change the Server node name.

```
AxxonSoft Axxon Next Server Configuration
Name that uniquely identifies the installed server within Axxon Next domain. Leave this blank to have the value initialized from the host name or set to the __KEEP__ to keep the value unmodified (if any).
Axxon Next server node name
QA-COURT-LINUX
<Ok>
```

4. Specify the port range beginning for Server operation.

```
AxxonSoft Axxon Next Server Configuration
This port is used to determine base port of a TCP port span for Axxon Next applications. You may need to change this value if you run several instances of Axxon Next on the same host.
TCP port - base for Axxon Next TCP ports range
49999
<Ok>
```

5. Specify the number of ports for Server operation.

```
AxxonSoft Axxon Next Server Configuration
In addition to the base port it determines TCP ports range used by Axxon Next applications.
Axxon Next TCP ports span
100
<Ok>
```

6. Specify the database operation port.

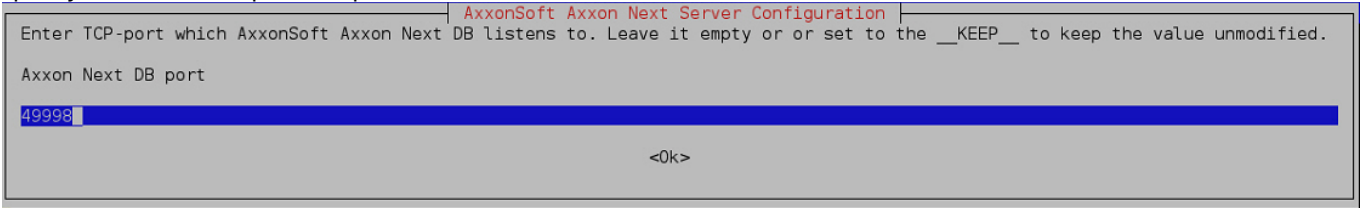

- 7. Restrict the visibility of Servers from various networks in the Servers list during the *Axxon Next* setup. Possible values:
 - a. "0.0.0.0/0" - Servers from all networks will be visible.
 - b. "10.0.1.23/32,192.168.0.7/32" - Only Servers from specified networks will be visible.
 - c. "127.0.0.1" - Only Servers from the local network will be visible.

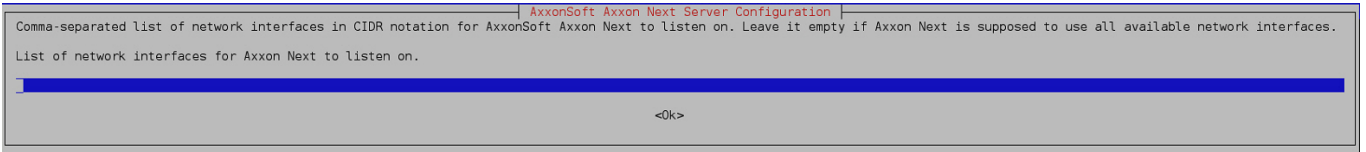

- 8. Set the external address of the switch if the Server is located behind the NAT (1). Use the following settings format: "IP Address 1 or DNS Name 1, IP Address 2 or DNS Name 2"

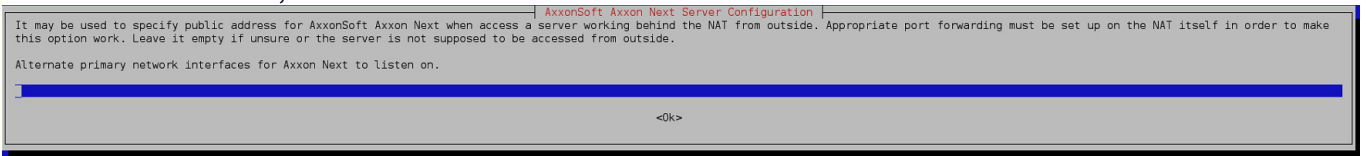

- 9. Select the Server log level (see [Configuring Logging Levels](#)).

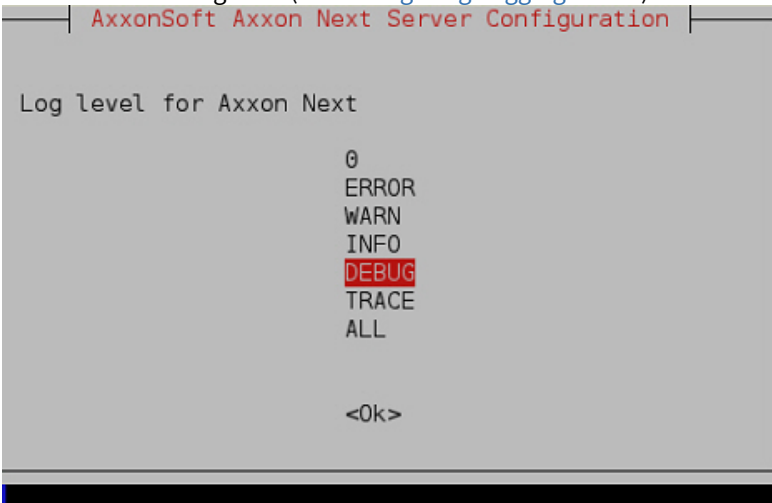

10.8.9 Configuring the metadata storage in NAS on Linux OS

To store the metadata in a network attached storage (NAS), do the following:

1. Create a shared network folder.
2. On the Server in Linux OS, create the **netdir** folder. For example, in the **/media** folder:

```
sudo mkdir /media/netdir
```

3. Install the **cifs-utils** utility.

```
sudo apt-get install cifs-utils
```

4. Attach the shared network folder to the created **netdir** folder.

```
sudo mount -t cifs //IP-address/common /media/netdir -o
user=User,password=123,uid=1001,gid=1002,vers=2.0
```

where,

- a. IP-address - NAS address,
- b. common - shared network folder,
- c. user, password - NAS access credentials,
- d. uid, gid - id of the user and ngp group; they can be obtained using the following command:

```
id ngp
```

5. In the Axxon Next metadata storage settings, specify the /media/netdir path (see [Configuring storage of the system log and metadata](#)).

After you restart Linux OS, the attached folder will be deleted. To configure the network folder to be attached on the OS loading, do the following:

1. Open the /etc/fstab file.

```
sudo nano /etc/fstab
```

2. Add the following string to the file:

```
//IP-address/common /media/netdir cifs user=User,password=123,uid=1001,gid=1002,vers=2.0 0
```

3. Save file.

10.8.10 Configuring the Axxon Next Client logging parameters on Linux OS

To change the Axxon Next Client logging parameters, do the following:

1. Execute the following command.

```
sudo dpkg-reconfigure axxon-next-client
```

2. Select the Client log level (see [Configuring Logging Levels](#)).

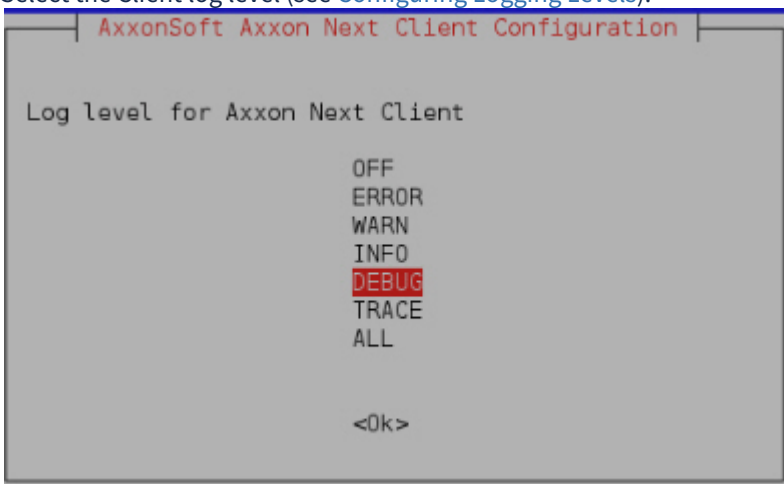

- Set the maximum size of the log in megabytes. When the specified size is reached, a new log is created.

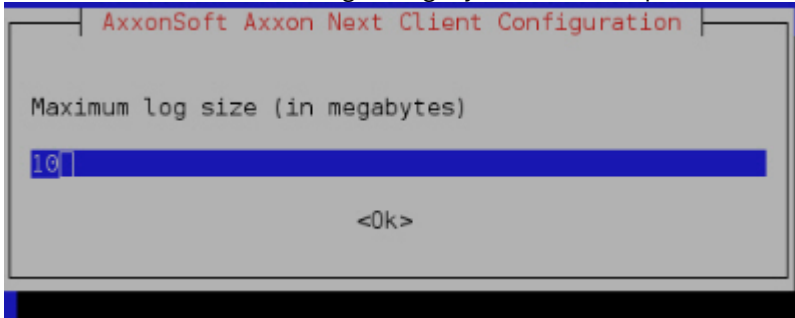

10.8.11 License activation for the LP recognition detection in Linux OS

To activate the License Plate (LP) recognition detection (see [Configuring License plate recognition \(VT\)](#)), do the following:

- Download the Sentinel LDK Run-time Environment:

```
sudo wget --no-check-certificate http://downloads.vitcompany.com/release/Sentinel/8.1/aksusbd-8.13.1.tar.gz
```

- Unpack the archive:

```
sudo tar zxvf aksusbd-8.13.1.tar.gz -C ~
```

- Get the AxxonArchiveSearchll.v2c key file from the technical support department.
- Move the received file to the folder with the unpacked archive.
- Go to the folder with the unpacked archive and run the following script:

```
cd aksusbd-8.13.1
sudo ./dinst
```

As a result, the installed key will be displayed at the <http://127.0.0.1:1947/> address in the Sentinel Admin Control Center web-application.



Options

Sentinel Keys Available on qa-t4

#	Location	Vendor	Key ID	Key Type	Configuration	Version	Sessions	Actions
1	Local	107392 (107392)	1009439054656752966	HASP SL AdminMode		7.60	•	Products Features Sessions Certificates C2V

Update/Attach

Access Log
Configuration
Diagnostics

Help
About

10.8.12 System data collection in Linux OS

To collect the system data in Linux OS, execute the following command:

```
sudo /opt/AxxonSoft/AxxonNext/bin/support /home/user
```

where

- /opt/AxxonSoft/AxxonNext/bin/support - the utility location directory;
- /home/user - the user's home directory.

10.9 Appendix 9. Using Axxon Next with NAT

10.9.1 Consolidating the Servers from different networks into Axxon domain

To consolidate the Servers from different networks separated by routers into Axxon domain, do the following:

1. Set the port range for operation and the router's public IP address on each Server that is to be included in the Axxon domain (see [Network settings utility](#)).

Attention!

The Server port ranges of Axxon Domain should not overlap within the same network.

By default, the base port is 20111, and the port range is 20111-20210. Hence, it is necessary to set and forward the port range 20211-20310 for the second Server, the port range 20311-20410 for the third Server, and so on.

Attention!

The router's public IP address should be static.

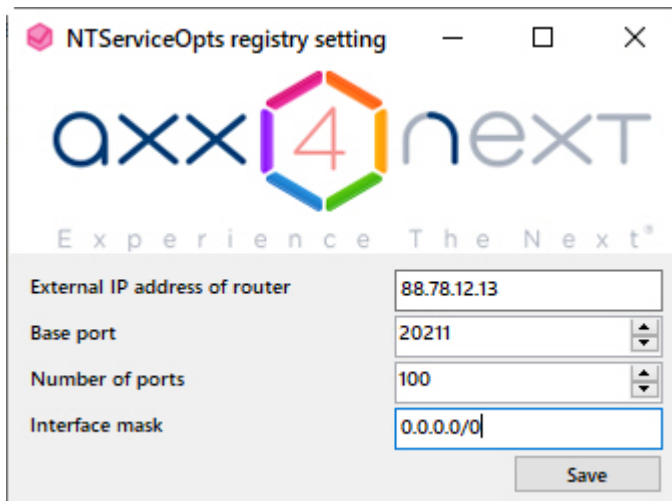

2. For each router, forward the specified ports of the Server, which is located behind this switch.
3. Connect the Client to the Server from any network (see [Starting an Axxon Next Client](#), [Connecting the Client to the Server behind NAT](#)).
4. Manually add other Servers to the Axxon domain using the public IP address of the corresponding router and the external base port of the Server (see [Adding a Server to an existing Axxon Domain](#)).

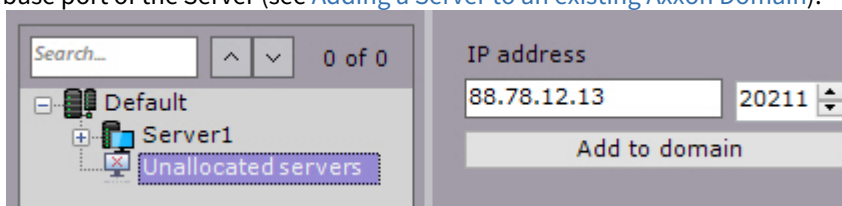

Example:

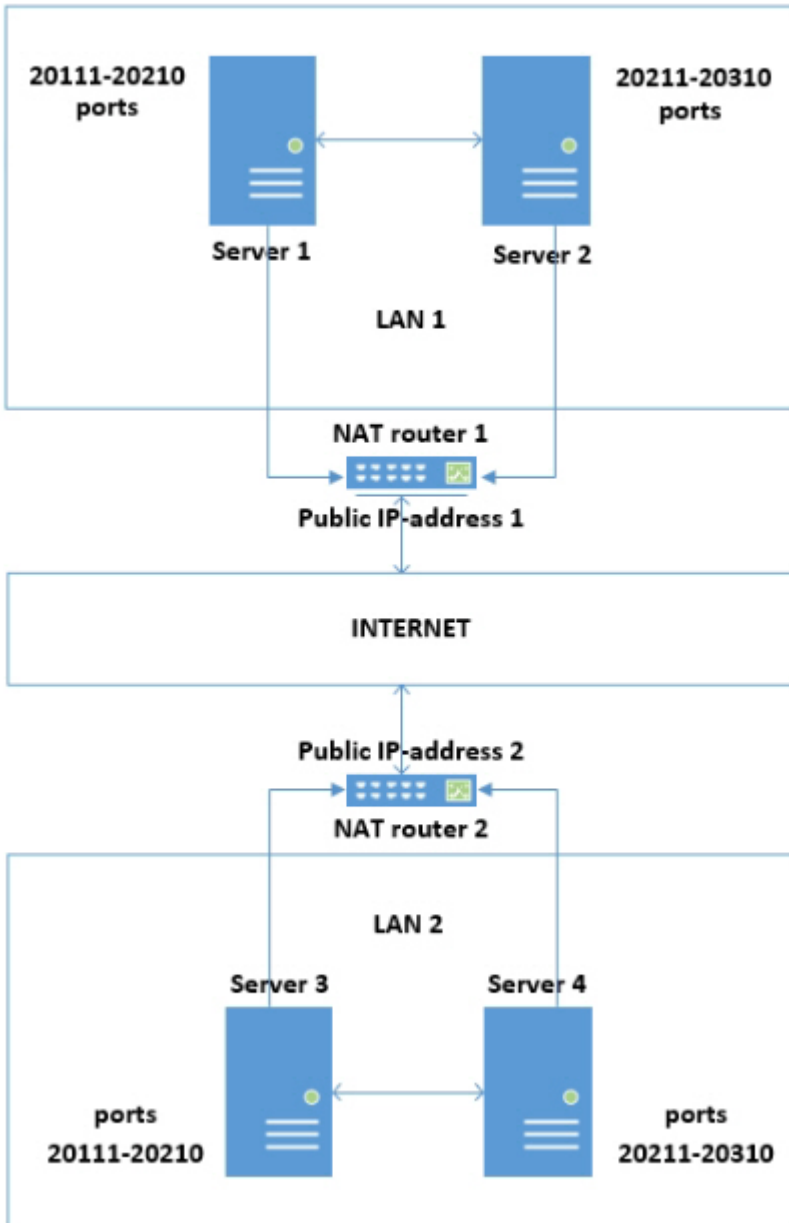

To combine Servers into one Axxon domain in this configuration, do the following:

1. On Server 1, set the port range 20111-20210 and the public IP address of router 1.
2. On Server 2, set the port range 20211-20310 and the public IP address of router 1.
3. On Server 3, set the port range 20111-20210 and the public IP address of router 2.
4. On Server 4, set the port range 20211-20310 and the public IP address of router 2.
5. On router 1, configure the forwarding of:
 - a. the router ports 20111-20210 to the internal IP address of Server 1 and ports 20111-20210;
 - b. the router ports 20211-20310 to the internal IP address of Server 2 and ports 20211-20310.
6. On router 2, configure the forwarding of:
 - a. the router ports 20111-20210 to the internal IP address of Server 3 and ports 20111-20210;
 - b. the router ports 20211-20310 to the internal IP address of Server 4 and ports 20211-20310.
7. Connect to Server 1.
8. Manually add Server 2 to the Axxon domain using the local IP address of Server 2 and port 20211.
9. Manually add Server 3 to the Axxon domain using the public IP address of router 2 and port 20111.
10. Manually add Server 4 to the Axxon domain using the public IP address of router 2 and port 20211.

10.9.2 Connecting the Client to the Server behind NAT

To connect the Client to the Server behind NAT, do the following:

1. On the Server, set the port range of ports for operation and the router's public IP address (see [NTServiceOpts utility](#)). By default, the base port is 20111, and the port range is 20111-20210.

Attention!

The router's public IP address should be static.

2. On the router, forward the specified Server ports and the NativeBL 20109 port.
3. Launch the Client and specify the router's external IP address and the Server's external base port in the connection settings (see [Starting an Axxon Next Client](#)).

Attention!

When connecting the Client from an external network, only those Servers that have access to the external network will be available in the Axxon domain configuration (see [Consolidating the Servers from different networks into Axxon domain](#)).

Attention!

In some cases, in security systems with a complex architecture (NAT, VPN), the Client may not receive events from the Server. To fix this, it is necessary to create the system variable `NGP_POLL_EVENTS` and set the 1 value to it (see [Appendix 10. Creating system variable](#)).

Attention!

In a failover system, it is not possible to connect to the node that is behind NAT (see [Connecting to a Node and Configuring of an Axxon domain](#)).

Example:

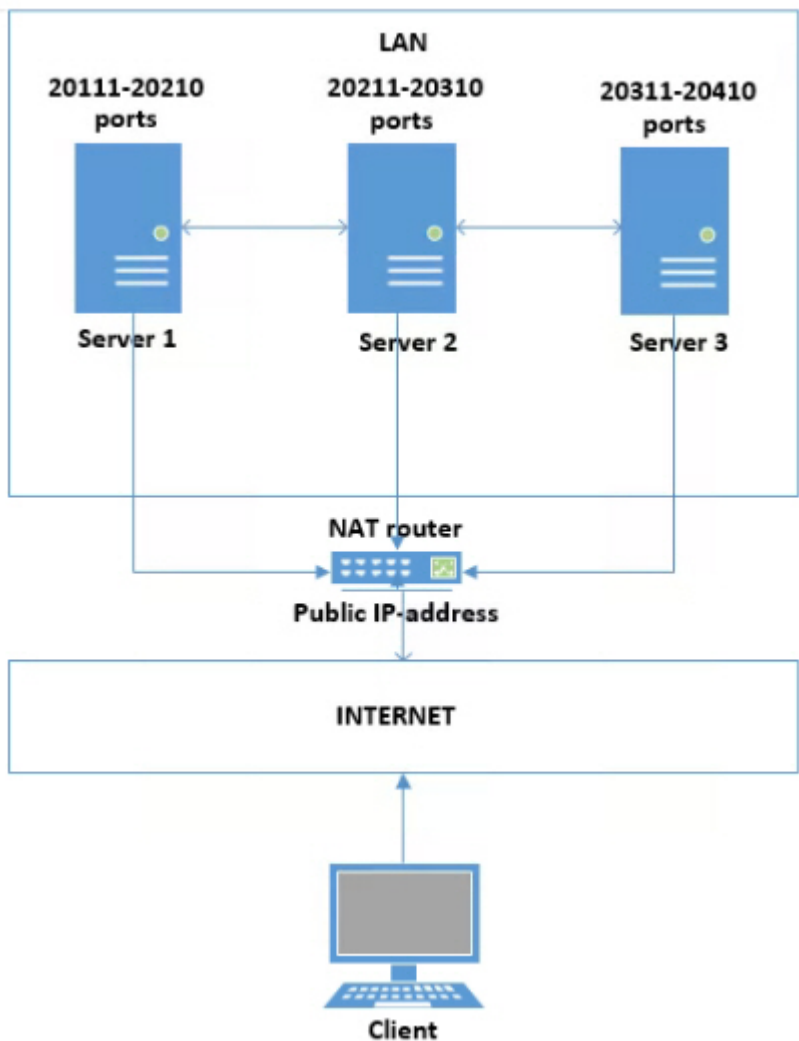

To connect the Client to the Servers behind NAT, do the following:

1. On Server 1, set the port range 20111-20210 and the public IP address of the router.
2. On Server 2, set the port range 20211-20310 and the public IP address of the router.

3. On Server 3, set the port range 20311-20410 and the public IP address of the router.
4. On the router, configure the forwarding of:
 - a. the router ports 20111-20210 to the internal IP address of Server 1 and ports 20111-20210;
 - b. the router ports 20211-20310 to the internal IP address of Server 2 and ports 20211-20310;
 - c. the router ports 20311-20410 to the internal IP address of Server 3 and ports 20311-20410.
5. When connecting the Client, enter the router's public IP address and port: 20111 to connect to Server 1; port 20211 to connect to Server 2; port 20311 to connect to Server 3.

10.9.3 Connecting the web and mobile Clients to the Server behind NAT

To connect web and mobile Clients to the Server behind NAT, do the following:

1. On the router, forward the specified port of the web server (see [Configuring the web server](#)). The default port is 80.

Web-server properties	
Certificate file	
Enable	Yes
Port	80
Private key file	
RTSP port	554
RTSP/HTTP port	554

Note

To access all Servers of the Axxon domain, it is enough to forward any single port of the web server.

2. When connecting using a web browser or mobile Client, use the Server's public IP address and the forwarded port of the web server (see [Starting the web client](#)).

Example:

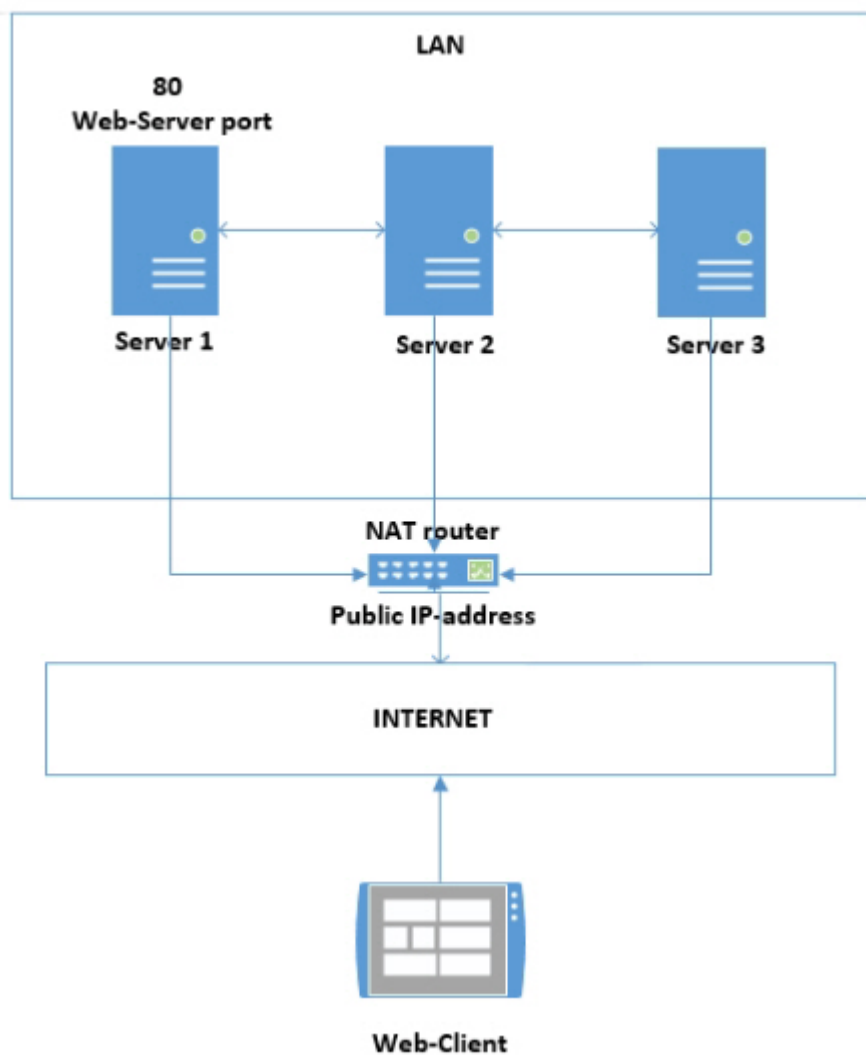

To connect the web Client to the Axxon domain in this configuration, do the following:

1. On the router, forward the port 80 to the internal IP address of Server 1 and port 80.
2. When starting the web Client, use the router's public IP address and port 80.

10.9.4 Audio transmission from the Client's microphone behind NAT to the Server's or camera's loudspeaker

Playing back sound from Client microphone on camera speakers

To transmit audio from the Client's microphone behind NAT to the Server's or camera's loudspeaker, do the following:

1. On the Client, specify a unique port range and an external router's public IP address. Follow the steps below:
 - a. Add an `NGP_CLIENT_PORT_BASE` environmental variable and set its value to the first port number in the range (see [Appendix 10. Creating system variable](#)).
 - b. Add an `NGP_CLIENT_PORT_SPAN` environmental variable and set its value to the number of ports in the range.

Attention!

We recommend you to use no less than 100 ports.

Attention!

If you have multiple Clients within your network, their port ranges must not overlap.

c. Add an `NGP_ALT_ADDR` environmental variable and set its value to the public IP address of the external router.

2. Configure forwarding of the specified ports on both external and internal router.

Example.

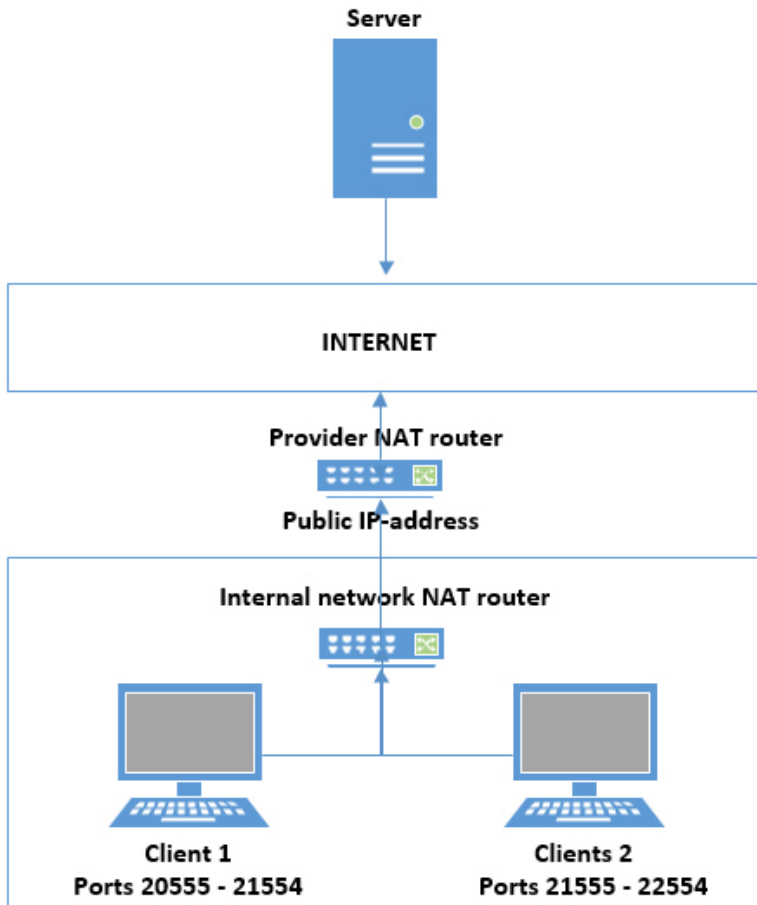

To transmit audio from microphones connected to Client 1 and Client 2 to the Server's or camera's loudspeaker, do the following:

1. On Client 1, set port range to 20555-21554, and the public IP address of your Internet provider's router.
2. On Client 2, set port range to 21555-22554, and the public IP address of your Internet provider's router.
3. Configure port forwarding on the internal router:
 - a. ports 20555-21554 to the internal IP address of Client 1 and ports 20555-21554;
 - b. ports 21555-22554 to the internal IP address of Client 2 and ports 21555-22554;
4. Configure port forwarding on the provider's router:
 - a. router ports 20555-21554 to the IP address of the internal router and ports 20555-21554;
 - b. router ports 21555-22554 to the IP address of the internal router and ports 21555-22554;

10.10 Appendix 10. Creating system variable

To add a new system variable:

1. Go to **Control panel** → **System** → **Advanced system settings**.
2. Click the **Environment Variables...** button.

3. Under **System variables** group, click the **New ...** button.
4. Specify the name and value of variable.

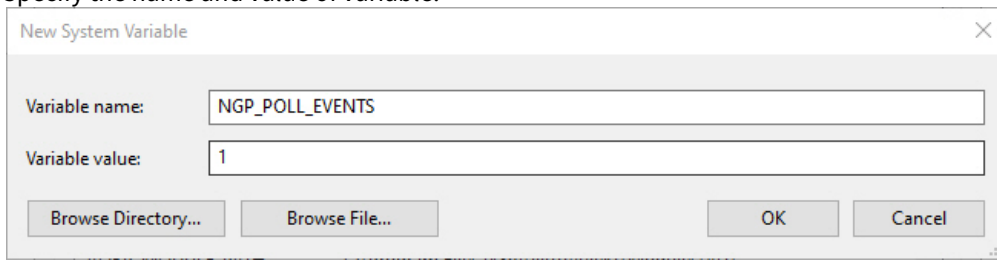

New System Variable

Variable name: NGP_POLL_EVENTS

Variable value: 1

Browse Directory... Browse File... OK Cancel

5. Click the **OK** button.